

1 Introduction

The ability to respond to environmental changes is crucial for the survival of organisms. Cells have to be capable of efficient adaptation to external variations, including stress situations, altered abundance of signaling molecules like hormones or cytokines, or the presence of pathogens like viruses or bacteria. A large variety of regulation mechanisms has evolved to tightly control cellular processes, however alteration of gene expression represents the most common way of mediating a response to environmental changes. Transcription factors constitute the key elements in this conversion of extra-cellular signals into altered genetic programs of cells.

The transcription factor Nuclear Factor-kappa B (NF- κ B) plays a pivotal role in regulating responses to many external stimuli and is involved in numerous cellular processes such as cell proliferation, apoptosis and the immune response. In the immune system, different processes of immune cell development, survival and function are regulated by NF- κ B. For example the recognition of pathogens by antigen-specific T or B cell receptors results in the induction of NF- κ B, which initiates productive activation and clonal expansion of T and B cells. Deregulation of NF- κ B signaling has been associated with various diseases, including chronic inflammation, autoimmune diseases and cancer. Therefore, understanding the molecular mechanisms underlying NF- κ B activation in different physiological and pathological settings is of great interest.

Posttranslational modifications of proteins influence a broad range of cellular functions. Attachment of molecules like phosphate, acetyl or methyl groups, or entire proteins like ubiquitin can greatly expand the diversity of the cellular proteome. In recent years poly-ubiquitination has emerged as an important multifunctional signal and has been shown to influence signaling pathways to NF- κ B in multiple ways.

In this thesis, aspects of the specific signal propagation process, which mediates NF- κ B activation upon T cell receptor stimulation, were investigated with a focus on ubiquitin and ubiquitin-like modifications of crucial mediators.

1.1 The ubiquitin system

Ubiquitination is involved in almost every cellular process due to the fact that it can dramatically affect fate and function of proteins. Ubiquitin represents a highly conserved 76 amino acid protein that shows ubiquitous expression in all eukaryotes. Multiple genes encode for ubiquitin either in the form of oligomers or fusions primarily with small ribosomal units. After ubiquitin has been processed to its active monomeric form, it can become covalently attached to its substrate proteins [1]. Conjugation with ubiquitin can target proteins for proteasomal degradation, but also regulates protein function, subcellular localization, and protein-protein interactions. Thus, ubiquitination plays an important role in fundamental cellular processes like endocytosis, metabolic homeostasis, protein quality control, signal propagation, transcription, translation and DNA repair [2, 3].

1.1.1 Molecular mechanism of ubiquitination

Ubiquitin becomes covalently conjugated to target proteins in a three-step mechanism by the subsequent action of E1, E2 and E3 enzymes (Fig. 1.1). Only one ubiquitin-activating enzyme (E1) exists in eukaryotic cells (Uba1). E1 adenylates the C-terminal glycine residue of ubiquitin, which enables the formation of a thioester bond between the C-terminus of ubiquitin and the catalytical cysteine of the E1. Ubiquitin is then transferred to the active site cysteine of an ubiquitin-conjugating enzyme (E2) by transesterification. Around 30 different E2s are known to exist in mammals to date. They all share a conserved core domain of approximately 150 amino acids (UBC-domain), which contains the active site cysteine. N- and C-terminal parts of E2s vary strongly, thereby providing the specificity for interactions with different ubiquitin ligases [4 and references therein]. Through the assistance of ubiquitin ligases (E3s), which bind E2 and substrate, ubiquitin is finally attached to the target protein by an isopeptide bond between the ϵ -amino group of a lysine (K) and the C-terminal carboxyl group of ubiquitin. Furthermore, conjugation to the α -amino group of proteins has been reported [5].

Ubiquitin ligases determine the substrate specificity of ubiquitination and can be assigned to two different classes: HECT and RING ligases. HECT E3 ligases contain a HECT (Homologous to E6-AP Carboxy Terminus) domain in their C-termini. A cysteine within the last 35 amino acids of this region accepts the ubiquitin from the E2 by formation of a thioester bond and then transfers it to the substrate [6]. The N-terminal regions of HECT ligases mediate their interaction with substrates and regulate their subcellular localization. RING

(really interesting new gene) ligases share a RING finger of 40 to 100 amino acids, containing eight conserved cysteine and histidine residues, which complex two zinc ions in a cross-braced mode [7]. RING ligases do not covalently bind the presented ubiquitin. They simultaneously associate with E2 and substrate and facilitate ubiquitination, however their exact mechanism of action remains unclear. The RING finger is nowadays thought to mainly function as a docking site for the E2 enzyme, thus bringing it in optimal position for ubiquitin transfer to the substrate [8, 9]. However, additional functions of the RING finger cannot be excluded [8] and induction of small conformational changes of the E2 by RING E3 binding has been suggested recently to facilitate ubiquitin release from the E2 cysteine in an allosteric fashion [10].

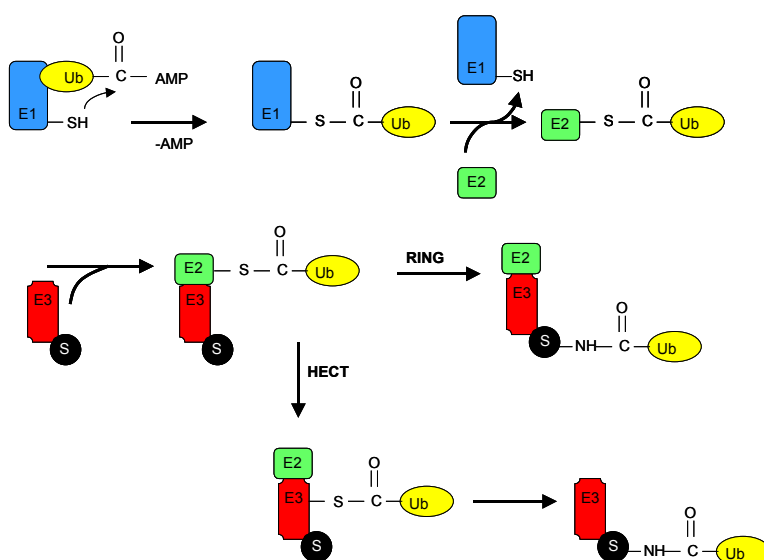

Figure 1.1: Ubiquitin conjugation mechanism.

Ubiquitin is activated and bound by E1 in an ATP-dependent manner and then transferred to the catalytic cysteine of an E2 by transesterification. E3s finally mediate ubiquitin conjugation to substrate proteins. While HECT E3s serve as catalytic intermediates, RING E3s exert their function by bringing substrate and E2 in optimal proximity.

1.1.2 Mono- and poly-ubiquitination

Conjugation of only a single ubiquitin molecule to a target protein exerts regulatory roles in endocytosis and membrane trafficking, but also in transcription and histone function [for review see 11, 12]. Poly-ubiquitination is achieved by ligation of additional ubiquitin molecules to lysines of ubiquitin. Although it seems that this process requires E3s, it remains unclear how they can specifically mediate both, the attachment of ubiquitin to a substrate and the addition of ubiquitin molecules to a growing chain [13]. Accessory factors (E4s) have been identified in some cases to facilitate ubiquitin chain formation and elongate chains once one ubiquitin is attached to the substrate, but E4s do not seem to be generally required [14, 15]. In total ubiquitin contains seven lysines (K6, K11, K27, K29, K33, K48 and K63), which

can serve as potential linkage sites and a recent proteomic study suggests that ubiquitin chain formation through all of them can occur in yeast although with different frequencies [16]. However, potential physiological roles of linkages through lysine residues besides K48 or K63 are largely undefined. Ubiquitin chains linked through K11 and K29 may be responsible for targeting proteins to the proteasome [17, 18], whereas linkage *via* K6 rather seems to serve a non-proteolytic role (Fig. 1.2) [19, 20].

The classical and most frequently used ubiquitin signal comprises linkage *via* K48 [16]. Chains of more than four K48-linked ubiquitin molecules are recognized by the 26S proteasome, thus targeting proteins for degradation [21]. This process is often used for fast on/off switches in regulating cellular protein levels and imparts general protein quality control [2, 22 and references therein]. In contrast, K63-linked poly-ubiquitin chains play a regulatory role for protein-protein interactions, protein localization and protein activity in proteasome-independent mechanisms of signal transduction, DNA repair, modulation of transcription factor activity, protein trafficking and stress responses (Fig. 1.2) [22, 23, 24, 25]. Structural studies revealed that the conformation of K63-linked ubiquitin chains is more extended than that of K48-linked chains [26, 27], which might allow adaptor proteins to distinguish between differently linked poly-ubiquitin chains.

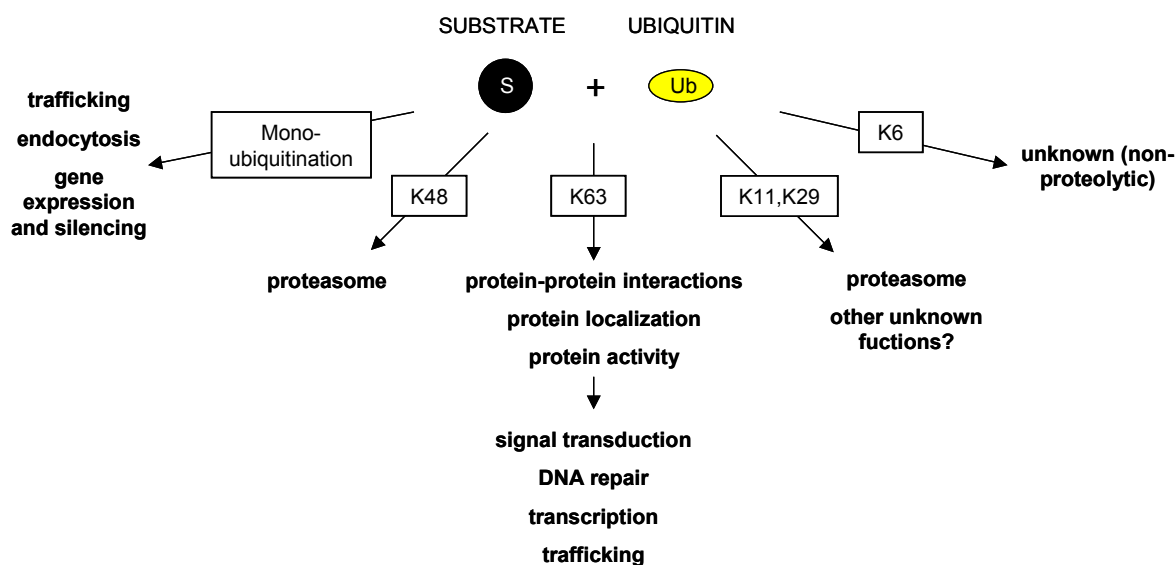

Figure 1.2: Ubiquitin chain linkages. Modification of substrates with one ubiquitin molecule (mono-ubiquitination) is involved in the regulation of protein trafficking, endocytosis, transcription and histone function. Poly-ubiquitination can occur through linkage of several ubiquitin molecules *via* different lysines residues. Dependent on the linkage, ubiquitin chains serve different functions inside cells.

1.1.3 The small ubiquitin-like modifier SUMO

In addition to ubiquitin, several ubiquitin-like modifiers have been discovered. The SUMO (small ubiquitin-like modifier) proteins represent one family of these ubiquitin-like modifiers. They share only about 20% sequence identity with ubiquitin, but show a similar fold, however with a very different surface charge distribution [28]. While only one SUMO protein exists in lower eukaryotes, four paralogs (SUMO-1, SUMO-2, SUMO-3 and SUMO-4) are found in mammals. Like ubiquitin, SUMO is synthesized as a longer precursor molecule and processing is needed to produce the C-terminal glycine required for conjugation. Processing is performed by SUMO-specific proteases, which can also cleave SUMO from substrates. Although SUMO-1, -2 and -3 have been shown to assemble chains *in vitro*, there is no functional significance assigned to SUMO chains so far and SUMO is in general thought to exert its cellular functions as a monomer [28].

The molecular mechanism of sumoylation is similar to that of ubiquitination. In an ATP-dependent manner the SUMO activating enzyme E1, a heterodimer of the proteins SAE1 and SAE2, forms a thioester between the C-terminal glycine of SUMO and the catalytical cysteine in SAE2. SUMO is then transferred to cysteine 93 of the SUMO-conjugating enzyme Ubc9, which represents the only known E2 for sumoylation [29]. Ubc9 itself can recognize substrates and transfer SUMO to the ϵ -amino group of acceptor lysines. Those lysines are generally located in the SUMO modification consensus motif ψ KxE, where ψ represents a bulky hydrophobic amino acid [30, 31]. Although Ubc9 can directly mediate transfer of SUMO to substrates, SUMO E3 ligases exist that can bind to Ubc9 and substrate-specifically facilitate SUMO conjugation, most probably by functioning as adaptors [32]. In higher eukaryotes, the PIAS family proteins (protein inhibitor of activated STAT), as well as RanBP2 (Ran binding protein 2) and Pc2 (Polycomb group protein 2) function as E3 ligases for SUMO. While PIAS proteins contain a RING domain similar to ubiquitin E3s, RanBP2 and Pc2 do not resemble HECT or RING ubiquitin E3s.

Conjugation of SUMO to a protein can influence its stability, subcellular localization, or interaction with other proteins or DNA. In several cases SUMO modification seems to alter the long-term fate of proteins despite its deconjugation. This is in line with the observation that compared to the physiological consequences a very small amount of substrate is generally modified, a fact which complicates the identification of new substrates [33]. Most of the so far identified SUMO substrates are involved in RNA metabolism, chromatin organization, DNA repair, or transcription. Concerning transcription, sumoylation can modify the arrangement of transcription factors at promoter sites and the recruitment of chromatin-modifying enzymes.

Sumoylation of transcription factors in general leads to transcriptional repression rather than activation [28]. Sumoylation has also been shown to be important for passage of cells through the cell cycle, for the maintenance of genomic integrity and signal transduction. Besides, SUMO can interfere with ubiquitination by conjugation to the same lysine residue. In addition, sumoylation influences subcellular localization and transport. Although SAE1/SAE2 and Ubc9 are mainly nuclear, they are also found at nuclear pore complex filaments in the cytosol [34]. Nuclear protein localization is required for sumoylation in many cases, nevertheless proteins also become modified in the cytosol. In this context, sumoylation has been implicated in mediating nuclear translocation of several substrates [32, 33]. However, it remains unclear if SUMO conjugation induces nuclear import or mediates nuclear retention.

1.2 The NF- κ B signaling pathway – an overview

1.2.1 NF- κ B and I κ B protein families

Nuclear Factor- κ B (NF- κ B) was initially identified as a transcription factor for B cell-specific gene expression through the immunoglobulin kappa light chain enhancer and was shown to possess constitutive transcriptional activity characteristic for this cell type [35]. However, NF- κ B was soon demonstrated to be ubiquitously expressed and required for inducible gene expression in multiple systems [36, 37, 38].

The NF- κ B transcription factor family comprises 5 proteins in mammals: p65 (RelA), RelB, c-Rel, p50/105 (NF- κ B1) and p52/100 (NF- κ B2), which act in cells as different homo- or heterodimers (Fig. 1.3). A p50/p65 heterodimer represents the most abundant of Rel dimers. NF- κ B family proteins share a characteristic 300 amino acids long N-terminal Rel homology domain (RHD), which is responsible for DNA binding, dimerization and interaction with the inhibitor of NF- κ B (I κ B) proteins [39, 40, 41]. Crystal structures of p50 homo- or p50/p65 heterodimers bound to DNA revealed that the N-terminal part of the RHD mediates specific DNA binding to the NF- κ B consensus sequence present in regulatory elements of NF- κ B target genes (5' GGGPuNNPyPyCC-3'), whereas the C-terminal part of the RHD is mainly responsible for dimerization and I κ B interaction [42, 43, 44]. p65, RelB and c-Rel contain transactivation domains (TAD) in their C-terminal regions, which are required for successful activation of transcription. p50 and p52 lack transactivation domains, and in resting cells

In addition, two mainly nuclear I κ B proteins have been characterized, Bcl-3 (B-cell chronic lymphocytic leukemia/lymphoma associated 3) and MAIL (molecule possessing ankyrin repeats induced by lipopolysaccharide), which do not function as inhibitors of NF- κ B proteins (Figure 1.3). Bcl-3 can bind to p50 or p52 homodimers in the nucleus, which results in activation of transcription [52, 54, 55], whereas MAIL seems to play a role in activating interleukin-6 production [56].

1.2.2 NF- κ B - stimuli and target genes

Many different stimuli lead to the expression of an NF- κ B gene signature and besides its well described role as a central mediator of the immune response, NF- κ B also functions as regulator of stress responses and influences apoptosis, proliferation, differentiation and development.

NF- κ B activity is induced by bacterial and viral infections and inflammatory cytokines, as well as by antigen receptor engagement, proving its crucial role for innate and adaptive immune responses. In addition, physiological (ischemia, hyperosmotic shock), physical (UV- or γ -irradiation) or oxidative cell stress can lead to activation of NF- κ B. [57] (Figure 1.4). In consequence, a great variety of target genes is induced by NF- κ B under various physiological and also pathological stimulatory conditions [58]. These include I κ B genes like I κ B α and p105, which leads to an autoregulatory feedback of the NF- κ B response. Other target genes are involved in inflammatory processes (cytokines, chemokines, cell adhesion molecules, acute phase proteins), immune response (immune receptor subunits, MHC molecules), regulation of apoptosis (anti-apoptotic Bcl family members, IAPs) and proliferation (cyclins, growth factors) [59, 60, 61]. A crucial role for NF- κ B in embryonic development and physiology of the bone, skin and central nervous system adds to the various functions of this pleiotropic transcription factor [41].

Since key cellular processes like cell survival, proliferation and immunity are regulated through NF- κ B, it is not surprising that deregulation of NF- κ B pathways by mutations of crucial mediators or other mechanisms leads to severe diseases associated with chronic inflammation, immunodeficiency, autoimmunity and cancer [62].

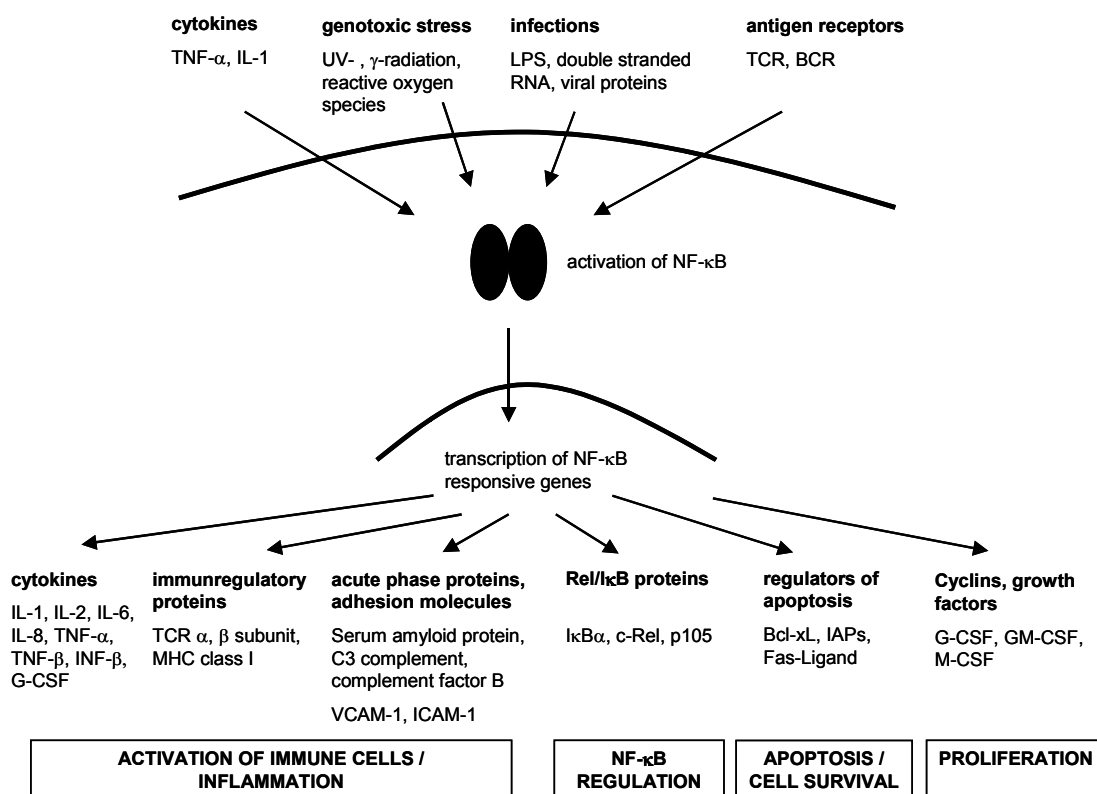

Figure 1.4: Stimuli and target genes of NF- κ B. Upon stress signals, infection, cytokine stimulation or antigen receptor ligation NF- κ B regulates the transcription of a variety of target genes. The induced expression of different cytokines, adhesion molecules, immunoregulatory and acute phase proteins pronounces the importance of NF- κ B in innate and adaptive immune responses.

1.3 Mechanisms of NF- κ B activation

Stimulus-dependent activation of NF- κ B is induced by degradation of I κ B proteins, which enables Rel dimers to translocate to the nucleus and exert their function [63, 64]. This degradation is induced by I κ B protein phosphorylation through specific I κ B kinases (IKKs). The cellular IKK complex contains two catalytically active kinases (IKK α and β) and the regulatory subunit NEMO/IKK γ . Two general types of signal propagation to NF- κ B activation exist, which are distinct in respect to the inducing stimuli, the involved IKK components and the targeted NF- κ B subunits (Figure 1.5). In addition, an atypical mode of NF- κ B activation originates from the nucleus upon DNA damage.

1.3.1 The canonical NF- κ B signaling pathway

The canonical pathway is induced by inflammatory cytokines, pathogen-associated molecules, and antigen receptors. It critically depends on IKK β and IKK γ , but does not require IKK α . Dependent on IKK γ , IKK β phosphorylates I κ B proteins at two serine residues (S32 and S36 in I κ B α , S19 and S23 in I κ B β and S18 and S22 in I κ B ϵ) [65, 66, 67, 68]. Phosphorylated I κ B proteins are then modified with K48-linked ubiquitin chains by ubiquitin ligases of the SCF or SCRF (Skp1-Culin-Roc1/Rbx1/Hrt-1-F-box) family. The receptor subunit β -TRCP (β -transducin repeat containing protein) senses the DS^PG Ψ XS^P motif of phosphorylated I κ B proteins and mediates conjugation of ubiquitin to lysines (K21 and K22 in I κ B α). Ubiquitination finally leads to proteasomal degradation of I κ B proteins and nuclear translocation of NF- κ B heterodimers, most of which contain p65.

1.3.2 The non-canonical NF- κ B signaling pathway

Besides the canonical NF- κ B activation pathway, a non-canonical or novel pathway has now been recognized that is induced by specific members of the TNF cytokine family like BAFF, lymphotoxin- β or CD40 ligand through the respective TNF receptors [reviewed in 69]. This pathway shows delayed kinetics compared to canonical NF- κ B signaling and requires IKK α , but not IKK β or γ , to selectively phosphorylate p100 associated with RelB [70]. This leads to ubiquitination and subsequent processing of p100 by the β -TRCP ligase and the 26S proteasome, respectively, and therefore to transcriptionally active p52/RelB dimers [49, 50]. IKK α is activated by direct phosphorylation through the kinase NIK (NF- κ B inducing kinase) [49, 70, 71]. The upstream signal propagation events are poorly understood, however, different members of the TRAF family have been shown to be recruited to the respective TNF receptors [69].

1.3.3 DNA damage induced signaling to NF- κ B

Upon DNA damage, activation of NF- κ B induces a cell survival program, which can together with DNA repair result in cell recovery in cases of only limited damage [72]. Induction of NF- κ B by DNA damage however requires nuclear events to trigger activation of the cytosolic IKK complex. Recent studies have shown that this is achieved by a series of IKK γ modifications. First, IKK γ that shuttles between cytosol and nucleus becomes sumoylated resulting in its nuclear retention. The attached SUMO is then replaced by ubiquitin, modifying

the same lysine residue. This process requires phosphorylation of $\text{IKK}\gamma$ by the DNA damage response kinase ATM (Ataxia Telangiectasia Mutated) [73]. According to the current model, ubiquitinated $\text{IKK}\gamma$ translocates to the cytosol and activates cytosolic IKK complexes by an yet unknown mechanism [74].

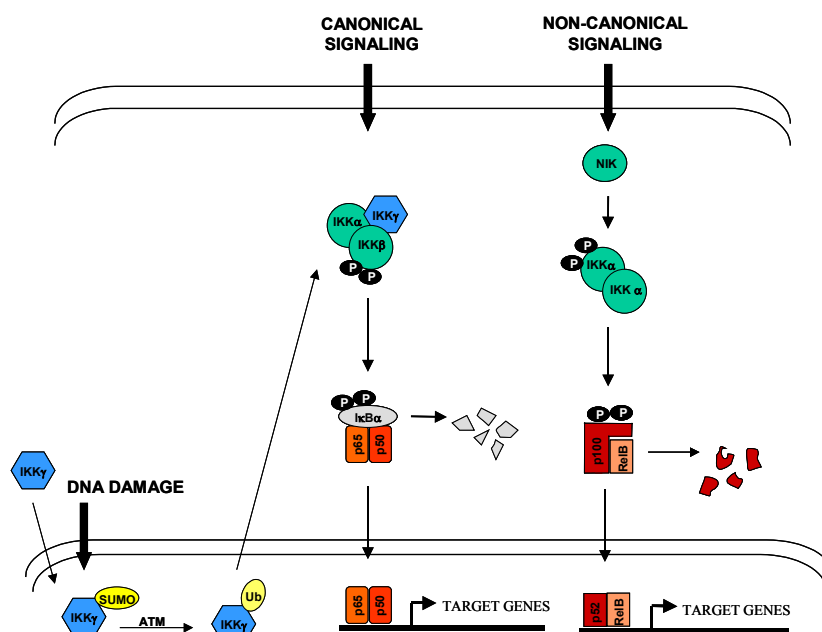

Figure 1.5: General modes of signal propagation for NF- κ B activation. A schematic representation of the basic mechanisms that lead to NF- κ B activation upon canonical, novel/non-canonical or DNA damage signaling is given. Ub, ubiquitin; SUMO, small ubiquitin-like modifier.

1.3.4 The I κ B kinase (IKK) complex – gatekeeper of NF- κ B signaling

A large protein complex of 700 to 900 kDa was found to specifically phosphorylate I κ B α at serines 32 and 36 [75]. Purification of this cytosolic I κ B kinase (IKK) complex identified two catalytically active kinases, termed IKK α and β [76, 77, 78, 79]. IKK α and β are ubiquitously expressed and show 52% overall sequence identity [78]. Both proteins contain an N-terminal kinase domain with 64% identical residues, a leucine zipper and a helix-loop-helix domain (HLH) in their C-termini (Figure 1.6). A so-called activation T-loop is located in the kinase domain. The leucine zipper is responsible for dimerization of the kinases, and mutations in this region render the kinases inactive [80]. The helix-loop-helix domain is dispensable for dimerization, but essential for optimal kinase activity [80]. The C-terminal parts of IKK α and β were shown to be necessary for their interaction with the regulatory subunit IKK γ , the third component of the IKK complex. This interaction is mediated by a hexapeptidic IKK sequence

(LDWSWL) termed the NEMO binding domain (NBD). Activation of IKKs is dependent on the phosphorylation of two serines (S177 and S181 in IKK β ; S176 and S180 in IKK α) in the sequence motif SLCTS found in the T-loop regions of both proteins [77, 81]. The kinase(s) responsible for this stimulus-dependent phosphorylation continue to be debated. In addition to potential IKK kinases like TAK1 or MEKK3, activating auto- or trans-autophosphorylation of the IKKs themselves was suggested [reviewed in 41, 69].

The physiological significance of IKK α and β has been analyzed in gene deficient mice. IKK β deficient mice exhibit embryonic lethality caused by severe liver apoptosis, a phenotype that resembles p65 knock-out mice [82, 83, 84]. Apoptosis is caused by TNF signaling in the developing liver, upon which due to the lack of NF- κ B activity no pro-survival and anti-apoptotic factors are induced. The crucial role for TNF signaling in this context is demonstrated by the fact that IKK β and p65 knock-out models can be rescued by crossing with TNF receptor-1 deficient mice [82, 85]. Congruently, IKK β deficient cells were shown to be unable to activate NF- κ B upon stimulation with proinflammatory cytokines such as TNF α or interleukin-1 (IL-1) [82, 83]. In contrast, IKK α deficient cells revealed only mildly effected NF- κ B activation by TNF- α stimulation [86], which underscores the crucial role for IKK β in canonical NF- κ B signaling. IKK α knock-out mice die shortly after birth and show morphological defects, mainly in skeleton and skin. In addition to non-canonical signaling to NF- κ B, IKK α seems to regulate developmental processes dependent and also independent of NF- κ B induced gene transcription [87].

IKK γ does not possess enzymatic activity and is structurally not related to IKK α or β . It consists of two coiled-coil domains in the N-terminal region, followed by a leucine zipper and a C-terminal zinc-finger domain (Figure 1.6). The first coiled-coil domain was shown to be required for interaction of IKK γ with the NEMO binding domain (NBD) in IKK α and β . The zinc finger domain (ZF) was reported to be necessary for signaling after stimulation with TNF α , LPS or CD40 ligand and upon genotoxic stress, thus playing a general role in IKK activation [88, 89, 90]. Similar to IKK β knock-out mice, IKK γ deficient mice are embryonic lethal due to massive apoptosis in the fetal liver. IKK γ deficient fibroblasts are incapable of activating NF- κ B in response to TNF, LPS, or IL-1, proving the crucial role for IKK γ in canonical NF- κ B signaling.

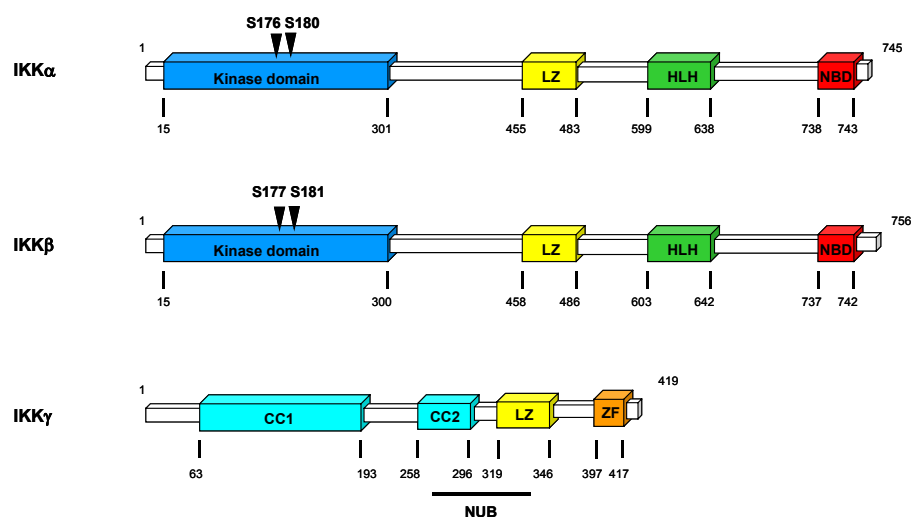

Figure 1.6: Subunits of the IKK complex. The kinases IKK α and β and the regulatory subunit IKK γ /NEMO are depicted showing their principle domain organization. Amino acid numbers are given for the human proteins. Acceptor serines for T-loop phosphorylation upon stimulation are marked by arrows. LZ, leucine zipper; HLH, helix-loop-helix domain; NBD, NEMO-binding domain; CC, coiled-coil domain; ZF, zinc-finger domain; NUB, NEMO ubiquitin-binding domain.

1.4 NF- κ B - a central regulator of inflammatory and innate immune responses

The immune system of vertebrates is capable of recognizing and defeating infectious microorganisms like bacteria, fungi, viruses, or parasites. The defense mechanisms can hereby be assigned to two categories: the innate and adaptive immune responses. The innate immune system represents the first defense line, exerting a fast but unspecific reaction before mounting an adaptive immune response. Immune cells can sense the invasion of microorganisms through the recognition of PAMPs (Pathogen-associated microbial patterns), surface markers or metabolites of these microbes, by Pattern recognition receptors (PPRs), which results in the secretion of cytokines and therefore induction of inflammatory reactions [reviewed in 91].

1.4.1 NF- κ B activation by Toll-like receptors

Toll-like receptors (TLRs) represent a family of 11 PPRs, that recognize a variety of PAMPs like LPS (lipopolysaccharides), double-stranded RNA, non-methylated CpG DNA (Cytosine-phosphatidyl-Guanosine) or flagellin. Engagement of all these receptors leads to NF- κ B dependent expression of various auto-, para- and endocrine cytokines. Secretion of these

cytokines promotes inflammation by activation of vascular endothelial cells, recruitment of additional immune cells to the sites of infection and initiation of monocyte to macrophage differentiation [reviewed in 92, 93, 94].

The intracellular domain of TLRs is homologous to that of the IL-1 receptor (TIR domain, Toll-IL-1-Receptor domain) and activation of NF- κ B by the IL-1 receptor is achieved through analogous signal propagation. Upon stimulation, the TIR domain recruits the cytosolic protein MyD88 (Myeloid differentiation factor 88) to the receptor [95]. Through its N-terminal death domain MyD88 brings the serine/threonine kinase IRAK (IL-1 receptor associated kinase) to the complex [96]. Although IRAK kinase activity does not seem to be required for NF- κ B activation, IRAK is necessary for the following recruitment of TRAF6 (TNF receptor associated factor 6) [97, 98]. This finally leads to activation of the IKK complex [99, 100, 101], though the direct link between TRAF6 and the IKK complex is still controversial. Recruitment of the adaptor molecules TAB1, 2 or 3 (TAK1 binding proteins) together with the kinase TAK1 (transforming growth factor- β activating kinase 1) to auto-ubiquitinated TRAF6 has been suggested [102]. Active TAK1 is then thought to phosphorylate IKK β at its T-loop serines, thereby initiating IKK activation (Fig 1.7) [101, 103].

1.4.2 NF- κ B activation by TNF-receptors

The family of tumor necrosis factor receptors (TNFRs) consists of at least 29 members that mediate responses to 19 known ligands. The main transcription factors activated by TNF signaling are AP-1 and NF- κ B, and by the balance of those two pathways TNF receptors can mediate both cell death and survival, mostly leading to cell activation under normal conditions. TNF α , the best studied of the TNF cytokine family members, is primarily produced by activated macrophages and can bind to two different receptors (TNFR1 and TNFR2), although most of the known activities of TNF α were found to be mediated by TNFR1 [104].

Binding of trimeric TNF α induces trimerization of TNFR1, which enables binding of TRADD (TNFR-associated death domain protein) to the cytoplasmic domain of the receptor. This results in recruitment of the proteins FADD (Fas receptor associated death domain) and TRAF2 (TNF receptor associated factor 2) [105, 106, 107]. While binding of FADD leads to caspase activation and subsequent apoptosis, TRAF2 associates with RIP1 (receptor interacting protein 1), a process required for NF- κ B activation. RIP1 is a serine/threonine kinase, however its kinase activity was shown to be dispensable for NF- κ B activation [106,

108]. Recently, it was reported that RIP1 is prone to conjugation with K63-linked ubiquitin chains upon $\text{TNF}\alpha$ stimulation. In addition, $\text{IKK}\gamma$ was demonstrated to be a sensor for poly-ubiquitin chains. It uses the region between amino acids 242 to 350, including parts of the second coiled-coil domain and the leucine zipper, to specifically bind to K63-linked ubiquitin chains. Consequently this region was termed NUB (NEMO ubiquitin-binding domain). Binding of K63-linked ubiquitin chains on RIP1 by $\text{IKK}\gamma$ was thus demonstrated to recruit the IKK complex to the TNF receptor [109, 110, 111] and was also suggested to be crucial for recruitment of the TAK1/TAB2/TAB3 complex through interaction with the ubiquitin-binding domains of TAB2 and 3 (Fig. 1.7) [110].

Recent studies suggest a mode of action of $\text{IKK}\gamma$ in IKK activation besides a scaffolding function. Interestingly, stimulus-dependent poly-ubiquitination of $\text{IKK}\gamma$ has been reported to occur in the TNF and also T cell receptor pathways [88, 112]. Despite the recurrent observation of stimulus-dependent $\text{IKK}\gamma$ ubiquitination and the hints that it represents a prerequisite for IKK activation, the exact function of this modification remains elusive. Current hypothesis include mediation of $\text{IKK}\gamma$ oligomerization due to conformational rearrangements or its own affinity for ubiquitin chains, or recruitment of IKK activators like the TAK1/TAB1/TAB2 complex [reviewed in 113].

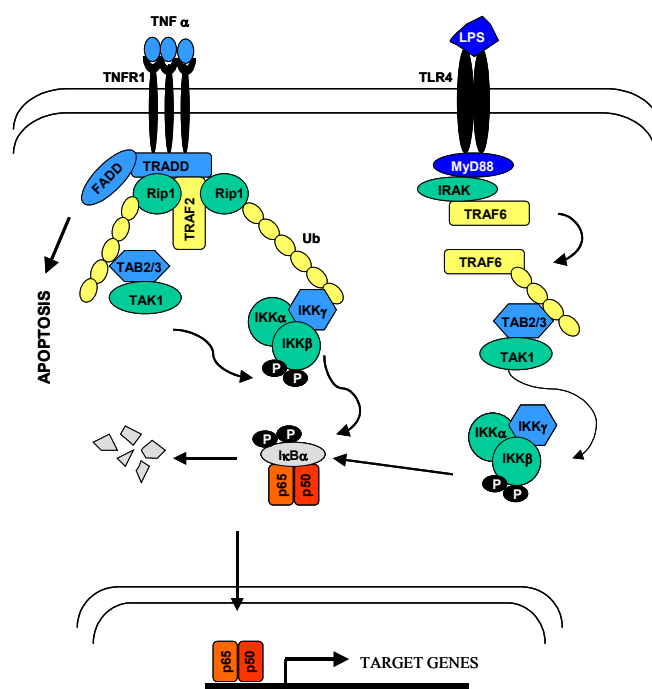

Figure 1.7: Mechanisms of TNF receptor and Toll-like/IL-1 receptor mediated NF- κ B activation. A schematic representation of the proteins and signaling processes involved in NF- κ B activation is given. A detailed description can be found in the main text.

1.5 NF- κ B in the adaptive immune response

The adaptive immune response enables the specific recognition and attack of pathogens and, importantly, confers the ability to memorize pathogens, thereby providing an increased protection against re-infection. It is mediated by T and B lymphocytes, which are able to kill infected cells or induce an antibody-based reaction upon antigen-specific activation. T cells are responsible for the specific recognition of a pathogen and therefore represent a central player in adaptive immunity.

1.5.1 The adaptive immune response

The adaptive immune response is initiated by immature dendritic cells, which are long-lived and reside in different tissues. These cells continuously take up extracellular material by receptor-independent macropinocytosis or can engulf pathogens by TLR mediated endocytosis. After uptake, a pathogen will be intracellularly digested. In case of infection, the dendritic cells are activated by proinflammatory cytokines, travel to the lymph nodes and present small antigen fragments on their surface major histocompatibility complex class II (MHC II) proteins (antigen-presenting cell, APC) [114, 115].

In the lymph nodes, APCs encounter naïve T cells, which express antigen-specific T cell receptors (TCRs). Due to somatic recombination, T cells have the potential to produce millions of different TCRs with affinities for various antigens. Every T cell, however, expresses only a single TCR of unique specificity on the surface. During T cell development in the thymus, a positive and negative selection process eliminates T cells with an affinity to self antigens, therefore ensuring self-tolerance. If a T cell recognizes its specific antigen presented by an APC, T cell activation leads to proliferation and clonal expansion [115, 116]. Depending on the physiological context, T cells differentiate upon activation into cytotoxic T cells (Tc) or T helper cells (Th). Cytotoxic T cells are able to recognize and kill cells, which indicate infection by presenting antigen fragments on MHC class I proteins. T helper cells can interact with and activate B cells, presenting the respective antigen fragment on MHC class II. While MHC class I proteins are expressed by almost every cell type, MHC class II proteins can only be found on the surface of immune cells. Activated B cells proliferate and differentiate into plasma cells, which produce and secrete specific antibodies (humoral immunity) [116, 117, 118]. In the course of infection, memory cells of each cell type are produced, which are long-lived and temporarily inactive. These cells confer a more rapid and

more efficient adaptive immune response upon a second infection with the same pathogen [116].

1.5.2 Activation of T cells

1.5.2.1 The T cell receptor

The α and β subunits of the T cell receptor are responsible for recognition of the antigen-MHC-complexes [119]. Because these subunits do not possess functional cytoplasmic domains, the signal is propagated by the directly associated subunits γ , δ , ϵ , termed CD3 complex, and ζ (Figure 1.8). The CD3 proteins and the ζ subunit contain intracellular immunoreceptor tyrosine-based activation motifs (ITAMs). Two tyrosine residues in these motifs become phosphorylated by receptor associated kinases upon antigen-MHC-complex binding, which induces intracellular signal transduction [116, 120].

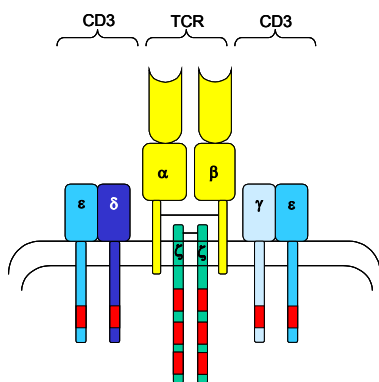

Figure 1.8: T cell receptor complex. Although the exact stoichiometry of the TCR is not definitely determined, two α/β heterodimers probably associate with one CD3 γ , one CD3 δ , two CD3 ϵ and one ζ homodimer. The α and β subunits recognize antigen-MHC-complexes. The signal is transduced by immunoreceptor tyrosine-based activation motifs (ITAMs). Each CD3 protein contains one ITAM, whereas a ζ subunit contains three (marked as red segments).
Adopted from [116].

1.5.2.2 The co-receptors CD4 and CD8

Specific recognition of the two different classes of MHC complexes by T cells is mediated by the marker proteins CD4 and CD8 on T helper cells and cytotoxic T cells, respectively. CD4 can specifically bind to MHC class II complexes, whereas CD8 only associates with MHC class I complexes. Because CD4 and CD8 interact with similar regions in the MHC proteins apart from the TCR binding site, CD4/CD8 and TCR association can occur simultaneously at the same MHC complex. Both, CD4 and CD8 strongly interact with the cytoplasmic tyrosine kinase Lck, thus bringing this kinase in close proximity to the TCR complex upon MHC binding and enhancing the TCR signal [116, 121, 122].

1.5.2.3 Co-stimulatory signals

Besides the self-tolerance selection control in the thymus, a second mechanism in T cell activation assures that autoreactive T cells cannot be activated by self-antigen presenting cells. This is due to the fact that a sole TCR/antigen-MHC contact does not suffice to induce T cell activation. Additional co-stimulatory signals are needed to trigger clonal expansion of the T cell. Those co-stimulatory signals reflect the existence of infection: proinflammatory cytokines induce the expression of B7 molecules on the surface of APCs [114]. The receptor for B7 on the T cell is CD28 and productive activation of a T cell can only occur upon concerted TCR/antigen-MHC and CD28/B7 interaction [reviewed in 123]. Once a dendritic cell has ingested a pathogen and is stimulated by cytokines at a site of infection, it is not able to take up another pathogen. In that way, this co-stimulatory mechanism of T cell activation directly links antigen-derived (TCR/antigen-MHC) and infection-derived (B7/CD28) signals. If the co-stimulatory signal and therefore a relation to infection is missing, the T cell stays inactive and becomes anergic. An anergic T cell is not susceptible to stimulation anymore, even if a co-stimulatory signal would be presented by subsequent encounter with a respective APC [124]. In addition to impeding auto-immune reactions, co-stimulatory receptors can enhance weak signals in case only a few TCRs are stimulated. A description of the signaling events arising from CD28 co-engagement can be found in chapter 1.5.2.5.2.

1.5.2.4 The immunological synapse

Interaction of the TCR with antigen-MHC complexes triggers remodeling of the actin cytoskeleton and orientation of the Golgi apparatus and microtubule organization centers (MTOCs) towards the site of cell contact [125]. Reorganization of the actin cytoskeleton and membrane microdomains (lipid rafts) leads to an enrichment of specific signaling mediators and thereby to the formation of a so-called immunological synapse or supramolecular activation complex (SMAC). The outer ring of this region (peripheral (p) SMAC) is characterized by accumulation of adhesion molecules like the integrin LFA-1 (lymphocyte function associated antigen-1). LFA-1 can bind to ICAM (intercellular adhesion molecule) expressed on the APC, thereby stabilizing the T cell/APC contact. In the central part (c-SMAC) TCR/MHC and CD28/B7 complexes enrich [126, 127]. In the c-SMAC lipid rafts are clustered, membrane microdomains which are rich in cholesterol and sphingolipids. Because some signaling mediators of the TCR pathway are constitutively associated with lipid rafts, while others are recruited upon stimulation, lipid rafts were thought to function in the

aggregation of signaling adaptors [128]. However, recent microscopy studies suggested that the clustering is mainly due to protein-protein interactions [129].

In addition, immunological synapse formation does not seem to initiate TCR signaling, because primary signals can be detected even before maturation of the synapse [130]. Thus, the immunological synapse could be required for secondary events. It was proposed to compensate for the relatively low affinity binding of TCR and MHC by increasing their local concentration (serial triggering). Other models suggest a function for polarized secretion of cytokines or cytolytic granules towards the respective target cell or controlled endocytosis of the TCR for downregulation of signaling [127, 130].

1.5.2.5 T cell receptor mediated activation of transcription

Productive activation of a T cell is mediated by the transcription factors NFAT, AP-1 and NF- κ B. Similar signal transducer proteins are used in the receptor proximal parts of the respective activation pathways, which then diverge strongly further downstream. This leads to a complex signaling network, which can be fine tuned at multiple levels by regulators specific for every transcription factors (Figure 1.9) [131].

1.5.2.5.1 Receptor proximal events

The protein tyrosine kinases Lck (lymphocyte protein tyrosine kinase), bound to the cytoplasmic tails of CD4 or CD8 co-receptors, and Fyn are associated with the T cell receptor complex. Upon stimulation, the transmembrane tyrosine phosphatase CD45 removes inhibitory phosphorylations from these kinases. This enables Lck and Fyn to phosphorylate the conserved tyrosines in the ITAM regions of the different CD3 proteins. The tyrosine kinase ZAP70 (zeta chain associated protein 70) is subsequently recruited to the phosphorylated ITAMs *via* its SH2 domain. ZAP70 phosphorylates the adaptor molecules LAT (linker for activation of T cells) and SLP-76 (SH2-containing leukocyte protein of 76 kDa) [132, 133]. These proteins in turn recruit adaptors like Grb2 (growth factor receptor-bound protein 2) and GADS (Grb2-related adaptor protein), as well as the p85 regulatory subunit of the PI3 kinase (Phosphoinositol-3 kinase), the phospholipase C γ (PLC γ) and the Rac/Rho-specific guanine nucleotide exchange factor Vav [134, 135]. PLC γ hydrolyzes membrane anchored PIP2 (phosphatidyl inositol 4,5 bisphosphate) to IP3 (inositol 1,4,5 trisphosphate) and DAG (diacylglycerol). DAG is a known activator of PKCs, including the novel isoform PKC θ , which plays an essential role for NF- κ B activation in TCR signaling [136]. In addition, DAG can activate the GTPase Ras, which results in induction of the MAPkinases Erk1/2, JNK and p38, and finally AP-1 activation by phosphorylation of Fos.

IP3 increases intracellular calcium levels and thereby activates the phosphatase calcineurin through interfering with the inhibitory effect of calmodulin. Calcineurin dephosphorylates NFAT, leading to its nuclear translocation and transcriptional activation (Figure 1.9) [131].

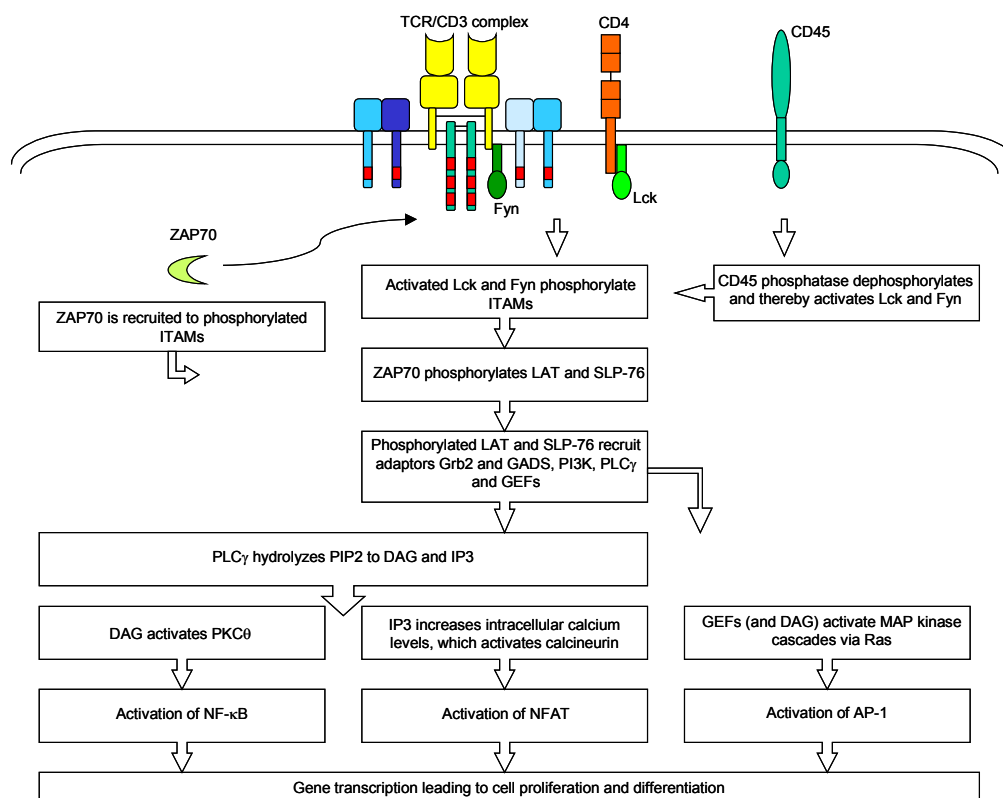

Figure 1.9: Schematic overview of the TCR signaling pathways leading to the activation of transcription factors NF- κ B, NFAT and AP-1. A more detailed description can be found in the main text. (modified from [116])

1.5.2.5.2 Signaling by the co-stimulatory receptor CD28

Co-stimulatory signals are thought to be mainly mediated through activation of NF- κ B, and CD28 stimulation alone can induce weak activation of the IKK complex. In general, co-receptors seem to enhance TCR signaling through lowering thresholds for TCR derived signals by influencing overlapping signaling pathways (quantitative model). Effects by separate pathways remain to be debated (qualitative model) [137, 138].

CD28 co-engagement seems to be involved in NF- κ B activation through two distinct pathways. After stimulus-dependent phosphorylation of CD28, possibly through Lck, the first pathway arises from the recruitment of the p85 regulatory subunit of PI3 kinase. Activated PI3 kinase phosphorylates inositol phospholipids to generate PIP2 (phosphatidyl inositol 4,5 biphosphate) and PIP3 (PI 3,4,5 trisphosphate), which localize to the membrane and recruit

Pleckstrin homology domain (PHD) containing proteins like PDK-1 (phosphatidyl-dependent kinase 1) and PKB (protein kinase B) [137, 139 and references therein]. Several routes of action have been suggested for PKB, which still remain controversial. One model proposes that phosphorylation of the threonine kinase Cot may finally lead to activation of NIK and therefore of the IKK complex [140]. PDK-1 mediates the recruitment of PKC θ and Carma1 to the immunological synapse (see 1.5.2.6.2 and 3) [141]. A second pathway of CD28 co-activation involves the interaction of Grb2 with the GEF Vav, which shows prolonged tyrosine phosphorylation and membrane localization upon co-stimulation compared to TCR stimulation alone and might therefore integrate TCR and CD28 derived signals [142, 143].

1.5.2.6 T cell receptor dependent activation of NF- κ B

NF- κ B triggers the expression of target genes regulating antigen-specific proliferation, differentiation into effector cells and survival of T cells, and therefore represents a central mediator of T cell activation [139]. IL-2 and the α -chain of the IL-2 receptor (CD25) belong to the group of NF- κ B target genes, which are required to induce clonal expansion. Furthermore, the NF- κ B target IL-4 regulates T cell differentiation, while the induction of BclXL and Bfl1/A1 exerts antiapoptotic functions [144, 145, 146].

1.5.2.6.1 PKC θ

The DAG-dependent protein kinase C isoform PKC θ is predominantly found in skeletal muscle and T cells. It is the only PKC isoform that is recruited to the cSMAC upon TCR stimulation [147] and was found to be indispensable for NF- κ B activation in this context [148, 149]. The exact mechanism of PKC θ activation remains unclear, but it involves membrane recruitment [148]. Besides the role of Vav and Lck in PKC θ membrane recruitment, PDK-1 has also been proposed to be involved. PDK-1 can phosphorylate PKC θ in its activation loop (threonine 538), which was suggested to promote recruitment and subsequent activation of PKC θ [139, 150].

PKC θ was first thought to exert its function *via* phosphorylation of actin-interacting proteins, thereby influencing the dynamic structure of the immunological synapse [151]. Recently, it was demonstrated that PKC θ can phosphorylate the scaffold protein Carma1 in its linker region, a crucial event in signal transduction to the Carma1/Bcl10/Malt1 (CBM) complex (see chapters 1.5.2.6.2 and 3) [152, 153].

1.5.2.6.2 Carma1, Bcl10 and Malt1 link PKC θ activation to the IKK complex

Based on genetic ablation in mice, the proteins Carma1, Bcl10 and Malt1 have been described as crucial mediators of TCR signaling downstream of PKC θ [154, 155, 156, 157, 158]. PDK-1 was shown to recruit Carma1, a permanently membrane-associated scaffold protein, to the immunological synapse [141]. A constitutive complex of Bcl10 and Malt1 then binds to Carma1 in a stimulus-dependent manner.

Carma1 (caspase recruitment domain (CARD) containing MAGUK protein1)

Carma1 (or CARD11) belongs to the protein family of membrane-associated guanylate kinases (MAGUK), which are known as scaffold proteins without enzymatic activity. They are located at membranes, e.g. at the neuronal synapse or at tight junctions, where they function to organize multiprotein signaling complexes at specialized regions [159, 160]. MAGUK proteins contain a typical array of the protein interaction domains PDZ (Psd95/Dlg/ZO-1 homologous) and SH3 (Src homology-3) and a guanylate kinase-like motif (GUK). Carma1, as well as its homologs Carma2 (CARD14) and Carma3 (CARD10), additionally comprises a coiled-coil and an N-terminal caspase recruitment domain (CARD) (Fig. 1.10). While Carma1 is predominantly expressed in hematopoietic cells, Carma3 can be found in all non-hematopoietic cells and Carma2 only in the placenta [161, 162, 163, 164].

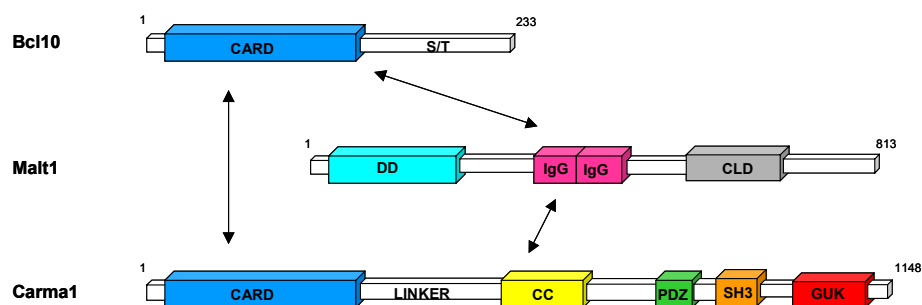

Figure 1.10: Domain organization of the CBM complex components Carma1, Bcl10 and Malt1. Association of Carma1 and Bcl10 occurs *via* CARD/CARD interaction. The IgG like domains of Malt1 were reported to bind to Bcl10 and Carma1. CARD, caspase recruitment domain; DD, death domain; IgG, IgG-like domain; CLD, caspase-like domain; CC, coiled-coil; PDZ, Psd95/Dlg/ZO-1 domain; SH3, Src homology domain; GUK, guanylate kinase-like motif.

Biochemical studies and the generation of a Carma1 deficient Jurkat T cell line first established a role for Carma1 in mediating TCR-dependent NF- κ B activation and reported binding of Bcl10 *via* CARD/CARD interaction. [161, 162, 163, 164, 165, 166]. The analysis of Carma1 deficient mice further supported the pivotal role of Carma1 in TCR and also BCR signaling pathways. Carma1 deficient mice show defective antigen-receptor mediated

proliferation and cytokine production of B and T cells due to impaired JNK and NF- κ B activation [154, 155]. The stimulus induced tyrosine phosphorylation pattern was unaltered, demonstrating unaffected receptor proximal events. Furthermore, activation of Akt, Erk, p38, AP-1 and calcium influx were comparable to wildtype animals, proving the pathway specific requirement of Carma1.

In line with these data, a mouse line (called unmodulated) carrying a point mutation in the coiled-coil region of Carma1 (L298Q) shows impaired antigen-receptor mediated activation of JNK and NF- κ B in B and T cells, while NFAT, Erk, and calcium signaling were comparable to wildtype animals [167]. In addition, T cells from these mice showed defective activation and proliferation after co-stimulation through the CD28 receptor [167], suggesting that TCR and CD28 pathways converge upstream of Carma1.

Carma1 is constitutively associated with membranes, and is known to bind to the TCR and to recruit Bcl10 upon T cell activation [154, 168, 169]. A mutation in the SH3 domain (L808P), that interferes with Carma1 membrane localization, is incapable of restoring NF- κ B activation in a Carma1 deficient Jurkat T cell line, indicating that localization of Carma1 is crucial for TCR signaling [169]. Thus, it seems that in Carma1 the SH3 domain rather than the PDZ domain, which normally mediates membrane localization of MAGUK proteins, may be responsible for the interaction with an yet unknown transmembrane protein. Additionally, deletion of CARD, SH3, or the GUK domain rendered Carma1 unable to reconstitute TCR-triggered NF- κ B activation, while deletion of the PDZ domain had no effect [166]. Thus, the PDZ domain might exert an NF- κ B unrelated function.

Bcl10 (B cell lymphoma 10)

The Bcl10 gene was originally identified by analysis of a chromosomal translocation, t(1;14)(p22;q32), found in approximately 5% of all mucosa-associated lymphoid tissue (MALT) lymphomas (see 1.5.2.6.5) [170, 171].

The 233 amino acid protein Bcl10 contains an N-terminal caspase recruitment domain (CARD), while its C-terminus does not show any sequence similarities, but a remarkable number of serine and threonine residues (Figure 1.10) [172, 173]. The CARD in general mediates homotypic interactions, is related to the death domains and can be found in several proteins involved in apoptosis regulation. Bcl10 was therefore first thought to be involved in the regulation of apoptotic processes, and depending on the experimental setting, Bcl10 overexpression resulted in NF- κ B activation or induction of apoptosis [171, 172, 173]. Surprisingly, genetic deletion of Bcl10 in mice did not cause any defects related to apoptosis

but severe immunodeficiency [156]. T and B cells of Bcl10 knock-out mice display defective antigen-receptor induced NF- κ B activation and proliferation, while MAP kinase, AP-1 and calcium signaling are normal. T cells are also unable to activate NF- κ B and produce IL-2 after stimulation with the PKC-activating PMA (phorbol-12-myristate-13-acetate) and ionomycin, and the overall tyrosine phosphorylation upon stimulation is comparable to wildtype animals. In addition, NF- κ B activation upon TNF α or IL-2 stimulation was normal. This reveals Bcl10 as a central and pathway-specific player in TCR mediated NF- κ B activation downstream of PKC θ . Through its CARD, Bcl10 was shown to interact with the scaffold protein Carma1 in a stimulus-dependent manner [168].

Malt1 (Mucosa-associated lymphoid tissue lymphoma translocation protein 1)

Malt1, also known as human paracaspase, is composed of an N-terminal death domain, followed by two IgG-like domains, and a C-terminal caspase-like domain (Figure 1.10). Translocations involving the MALT1 gene were found in subsets of MALT lymphomas (see 1.5.2.6.5) [174, 175, 176, 177].

Bcl10 and Malt1 are constitutively associated in unstimulated T cells and cooperate in NF- κ B activation by transducing the signal to the IKK complex [178, 179, 180]. The Bcl10/Malt1 interaction involves the region C-terminal of the CARD in Bcl10 and the two IgG-like domains of MALT1. Binding of Bcl10 to Malt1 was reported to induce Malt1 oligomerization [178]. A direct contact between the IgG-like domains of Malt1 and the coiled-coil region in Carma1 was also proposed [181]. Malt1 is thought to act downstream or at the level of Bcl10 because NF- κ B activation through Bcl10 overexpression is impaired in Malt1 $-/-$ cells [158]. In addition, overexpression of Malt1 can only induce NF- κ B activation in cooperation with Bcl10 or through artificially induced oligomerization [178]. It remains unclear if the MALT1 caspase-like domain possesses proteolytic activity and if so, whether this activity is needed for NF- κ B activation [reviewed in 182].

The generation of two different Malt1 deficient mouse models revealed a lymphocyte specific phenotype in both cases [157, 158]. T cells from those mice are defective in NF- κ B activation, cytokine production and proliferation upon TCR stimulation. In addition, both mouse models show reduced numbers of marginal zone B cells, while the T cell populations were comparable to wild type animals. However, differences between the two Malt1 deficient mice exist. One mouse model shows an impairment of JNK activation in T cells [157], while this process is fully functional in the other [158]. In addition, B cell phenotypes clearly differ in their severity. While B cell responses were found to be defective upon IgM stimulation in

one case [158], there was only a slight impairment in the other [157]. Although the mechanistic details underlying these differences are not understood, it is clear that Malt1 represents a crucial signaling mediator of NF- κ B activation upon TCR stimulation.

1.5.2.6.3 Signaling via the Carma1/Bcl10/Malt1 complex (CBM)

Recent publications shed light on the role of PKC θ for induction of CBM activity. Carma1 and PKC θ are recruited to the cSMAC upon TCR stimulation in a PDK-1 dependent manner, which brings them into close proximity [141]. In T cells, Carma1 is phosphorylated by PKC θ in its linker region (aa 442-660 in hCarma1) between the coiled-coil and PDZ domain. Carma1 phosphorylation was also observed in B cells, where it is mediated by PKC β [152, 153]. Serine 552 was reported as the major site of phosphorylation *in vitro*, and serines 555 and 645 as additional sites relevant for NF- κ B activation [152]. Mutant forms of Carma1, in which serines 552 or 555 were replaced by alanine residues (S552,555A), failed to reconstitute NF- κ B activation in Carma1 deficient T cells. It was also demonstrated that deletion of the linker region results in constitutive and PKC-independent NF- κ B activation. Carma1 S552,555A showed normal membrane localization and enrichment in the immunological synapse, but recruitment of Bcl10 and IKK γ was defective. In addition, phosphorylation of the linker region was shown to impair its interaction with the CARD [153]. Thus, the current model implies that phosphorylation of the linker region induces a conformational change in Carma1, that renders the CARD accessible. This enables the stimulus-dependent recruitment of the constitutively associated Bcl10/Malt1 to Carma1 and thus CBM complex formation.

How Bcl10 and Malt1 then transmit the signal to the IKK complex to finally activate NF- κ B is still a matter of debate. Phosphorylation of Bcl10 has been implied, but several studies rather assigned a negative regulatory function for T cell activation (see 1.5.2.6.4).

Recently, the RING ubiquitin ligase TRAF6 has been implicated in NF- κ B activation in T lymphocytes [183]. TRAF6 represents one of six members of the TRAF (Tumor necrosis factor receptor associated factor) protein family. These proteins were originally identified to mediate TNF receptor signaling and share a homologous C-terminal domain, the TRAF domain. This domain is responsible for binding to receptors, other TRAFs or different signaling proteins [184]. TRAF6 is unique in the fact that it is also required for signal propagation downstream of the TLR/IL-1 receptors [99, 100] and that it recognizes different regions in the cytoplasmic domains of TNF receptors than TRAF1, 2, 3 and 5 [185, 186]. TRAF6 was shown to bind to a conserved Pro-X-Glu-X-X-(aromatic/acidic residue) motif in

the TNF receptors, which is also found in IRAK proteins, providing an explanation for the involvement of TRAF6 in IL-1R and TLR pathways [186]. Recently, the conjugation of K63-linked poly-ubiquitin chains by a TRAF6/Ubc13 (Ubiquitin conjugating enzyme 13)/Uev1A (Ubiquitin E2 variant 1A) complex on TRAF6 itself or other downstream signaling molecules has been shown to be required for MAPK and IKK activation [101, 187, 188]. Furthermore, TRAF6 auto-ubiquitination can be strongly enhanced by its oligomerization [101, 189].

RNAi mediated knock-down of TRAF6 and TRAF2 was demonstrated to impair NF- κ B activation upon TCR stimulation. The same effect was achieved by overexpression of a TRAF6 dominant negative construct [183, 190]. In addition, interaction between Malt1 and TRAF6 was observed upon overexpression and in *in vitro* studies, and it was shown that TRAF6 can bind to the C-terminus of Malt1 through two conserved TRAF6 consensus sites in Malt1 (residues 640-646: PEETGSY and residues 783-798: PVETTD). Thus, it was suggested that Bcl10-dependent Malt1 oligomerization induces oligomerization and therefore activation of TRAF6 [183]. Activated TRAF6 is then thought to polyubiquitinate IKK γ , a process required for IKK complex activation, and to activate TAK1 probably through TAB1/TAB2 binding to ubiquitin chains (as described for TLR signaling in 1.4.1). Congruently, RNA interference mediated decrease of TAK1 protein levels impaired TCR induced NF- κ B activation [183].

An independent study also reported conjugation of K63-linked ubiquitin chains to IKK γ as a prerequisite for IKK activation in TCR signaling [112]. This study showed that Bcl10 targets IKK γ for ubiquitination in a Malt1- and Ubc13-dependent manner. Lysine 399 of NEMO was mapped as the acceptor site for ubiquitination, however, a K399R IKK γ mutant showed only partially impaired ability to activate NF- κ B. Since ubiquitination of a recombinant C-terminal Malt1 construct in the presence of E1, E2 and ATP was observed, MALT1 ubiquitin ligase activity was proposed, that could directly mediate IKK γ ubiquitination.

In addition, Caspase8, which is known for its function as an initiator caspase in death receptor dependent apoptosis, was reported to be another crucial mediator of T cell receptor signaling to NF- κ B [191]. Although the detailed mode of action remains unclear, stimulus-dependent interaction of Caspase8 with the CBM and the IKK complex could be demonstrated, pointing at a bridging or stabilizing function. While IKK γ ubiquitination is unaltered in Caspase8 deficient cells, no phosphorylation of IKK α/β could be observed. This finding strengthens that IKK γ ubiquitination alone is not sufficient to activate the IKK complex. In the following, it was also reported that TRAF6 interacts with active Caspase8 and is involved in its recruitment to lipid rafts [190].

Although several studies have supported a role for TAK1 in antigen-receptor dependent NF- κ B activation, the functional involvement of TAK1 is still a matter of debate. Through TAB1, TAB2, and TAB3 proteins, TAK1 is thought to associate with K63-linked ubiquitin chains conjugated to activated TRAF6, to IKK γ or another undefined mediator and to subsequently phosphorylate the IKK β activation loop (see also TNF/TLR signaling, Fig 1.6). Interestingly, a minimal pathway from Bcl10 to IKK α phosphorylation could be reconstituted *in vitro* with recombinant Bcl10, Malt1, TRAF6, Ubc13, E1, ubiquitin and the TAK1 and IKK complex components [183]. siRNA mediated knock-down in Jurkat cells [183] and ablation in a chicken B cell line [192] further support a role for TAK1 in TCR and BCR signaling to NF- κ B. However, controversial results have been obtained in TAK1 deficient T and B cells. TAK1 deficient B cells from mice were not impaired in NF- κ B activation after BCR stimulation [193]. In contrast, TAK1 was demonstrated to be necessary for NF- κ B activation upon TCR stimulation in naïve T cells from conditional TAK1 deficient mice [194, 195]. However, one study also revealed that TAK1 was not required for antigen-receptor induced IKK activation in effector T cells [195]. Thus, further research is needed to clarify the described discrepancies concerning TAK1.

Taken together, TRAF6 (and maybe TRAF2), TAK1 and Caspase 8 seem to link CBM to IKK complexes, but the molecular mechanisms are poorly investigated (Figure 1.11).

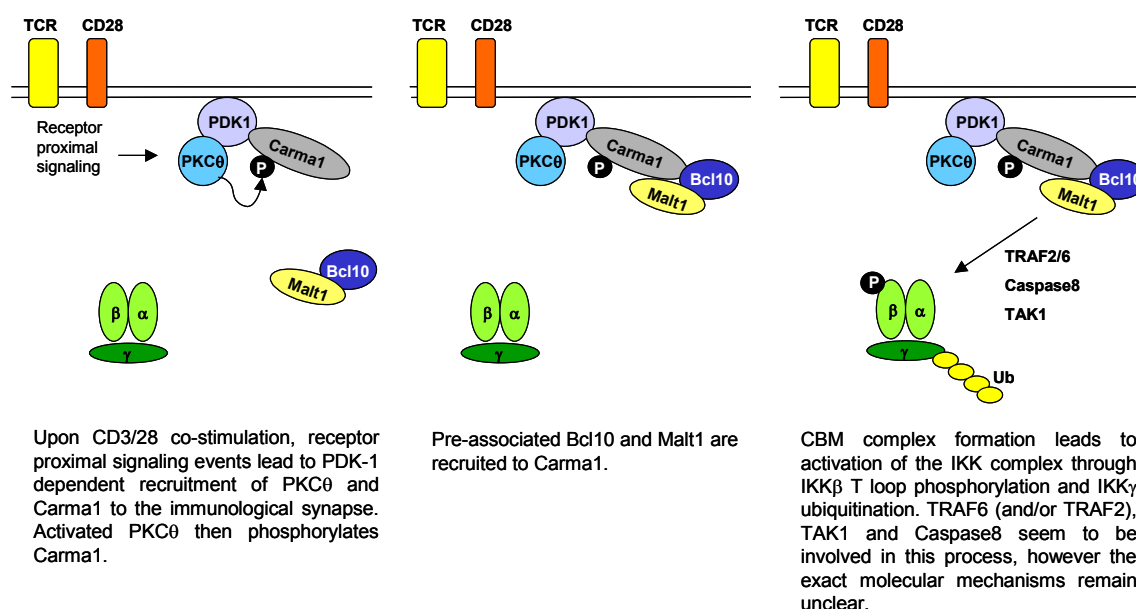

Figure 1.11: Simplified representation of proteins and mechanisms involved in TCR-dependent NF- κ B activation. Upon CD3/28 co-stimulation PDK1 recruits PKC θ as well as Carma1 to the immunological synapse. PKC θ phosphorylates Carma1 in its linker region, which leads to a conformational change, enabling association of Bcl10/Malt1 with Carma1 through CARD/CARD homotypic interaction. Subsequent activation of the IKK complex through IKK β phosphorylation and IKK γ ubiquitination seems to involve TRAF6 and/or TRAF2, as well as Caspase8 and TAK1.

1.5.2.6.4 Negative regulation of CBM signaling

The observed stimulus-induced phosphorylation of Bcl10 has recently been linked to a negative regulatory function for NF- κ B activation by several studies [180, 196, 197, 198].

We have shown that IKK β serves a dual role upstream of its classical substrates by being required for initial CBM complex formation. Subsequently, IKK β phosphorylates several serine residues in the C-terminus of Bcl10 (S134, S136, S138, S141, S144). This phosphorylation interferes with Bcl10/Malt1 association and leads to downregulation of TCR signaling. Thus, IKK β dependent phosphorylation of Bcl10 might represent a negative feedback mechanism by mediating disengagement of the CBM complex [180]. Others have confirmed the negative regulatory role of phosphorylation in this region, even though a different mechanism was suggested [197]. IKK β dependent Bcl10 phosphorylation has also been reported to occur at different serines located in the CARD domain and to directly mediate proteasomal degradation of Bcl10 [196]. In addition, Bcl10 phosphorylation through the Ca²⁺/calmodulin-dependent protein kinase II (CaMKII) on serine 138 was shown to attenuate TCR-dependent NF- κ B activation by a so far uncharacterized mechanism [198].

Ubiquitination-dependent degradation of Bcl10 has also been demonstrated to down-regulate TCR signaling, however different E3 ligases (Nedd4, Itch and cIAP2) and different mechanisms of degradation have been proposed [reviewed in 199].

1.5.2.6.5 CBM complex dysfunctions in lymphomas

MALT lymphomas belong to the group of non-Hodgkin marginal zone B-cell lymphomas and are characteristically found in the stomach, lung or salivary gland. They develop in a multistage process, which is best understood for gastric MALT lymphomas. Here they arise from lymphoid tissue accumulated through long-term antigenic stimulation due to chronic gastroduodenal infection with *Helicobacter pylori*. These low-grade lymphomas are restrained to the gastric mucosa and critically dependent on the presence of intratumoral T cells specific for *H. pylori*, so that 75% of these MALT lymphomas can be cured by *H. pylori* eradication. However, once the tumor disseminates to lymph nodes, it loses this dependence on *H. pylori* and can occasionally transform into more aggressive diffuse large B cell lymphomas (DLBCL) [200, 201].

Three translocations have been identified in MALT lymphomas that involve Bcl10 and Malt1 genes: t(1;14)(p22;q32), t(14;18)(q32;q21) and t(11;18)(q21;q21) (Table 1.1) [200, 201].

The translocation t(1;14)(p22;q32) locates the Bcl10 gene to the immunoglobulin heavy chain locus. This leads to increased Bcl10 expression through the proximity of potent B cell

transcriptional enhancers and to the generation of mutant forms due to somatic hypermutation mechanisms in this region [170, 171]. Similar, the translocation t(14;18)(q32;q21) places the MALT1 gene at the immunoglobulin heavy chain locus [174]. It is unclear how this relates to oncogenesis, however – as seen for Bcl10 - overexpression and further mutation of Malt1 might be involved.

The t(11;18)(q21;q21) translocation leads to expression of a fusion protein, which contains the N-terminal BIR domains (baculovirus inhibitor of apoptosis protein repeat) of cIAP2 (inhibitor of apoptosis) and the caspase-like domain of Malt1, and is capable of activating NF- κ B [175]. Several modes of action of this fusion protein in oncogenesis have been proposed. First, the BIR domains were shown to mediate stimulus-independent oligomerization of Malt1, which is thought to be necessary for downstream activation processes, and might therefore lead to constitutive NF- κ B activation [178]. Second, the BIR domains themselves can inhibit caspases and therefore apoptosis, leading to an uncontrolled proliferation advantage [202]. Recently, cIAP2 was also reported as E3 ligase responsible for ubiquitination and degradation of Bcl10 [203, 204]. Because the IAP2-Malt1 fusion protein lacks the RING E3 domain of cIAP2 and is therefore catalytically inactive, this is in line with the observed slight overexpression of Bcl10 in MALT lymphomas carrying the t(11;18)(q21;q21) translocation. Interestingly, the expression of IAP2-Malt1 in mice and cell lines leads to an augmented ubiquitination of IKK γ , which was also observed in MALT lymphomas bearing the t(11;18)(q21;q21) translocation. This links the translocation to deregulated ubiquitin ligase activity, however data concerning an involvement of TRAF6 in this process are contradictory [205, 206].

Interestingly, an abnormal nuclear localization of Bcl10 was observed in most Malt1 lymphomas containing Bcl10 t(1;14)(p22;q32) or Malt1 t(11;18)(q21;q21) translocations [207-209, 210]. How this altered localization affects oncogenesis is unclear, but nuclear Bcl10 localization seems to correlate with resistance of MALT lymphomas to *H. pylori* eradication and to refer to more advanced and aggressive lymphoma forms.

In addition to MALT lymphomas, a loss-of-function RNA interference screen recently discovered the importance of Carma1, Malt1, and Bcl10 for the constitutive IKK activity in a subset of DLBCLs (activated B-cell-like type, ABC) despite the absence of gene translocations or upregulated expression of Bcl10 and Malt1 [211]. Since activated B-cell-like DLBCLs rely on constitutive NF- κ B activation for survival, the CBM complex components, especially Carma1 due to its lymphoid system restricted expression, represent attractive therapeutic targets for ABC DLBCLs.

	t(11;18)(q21;q21)	t(14;18)(q32;q21)	t(1;14)(p22;q32)
Product	cIAP2-Malt1 fusion protein	overexpression of Malt1	overexpression of Bcl10
% of cases	15-40%	20%	2%
Localization	stomach, lung, intestine	salivary gland, skin, liver, lung	stomach, lung
Bcl10 expression	nuclear, strong	cytoplasmic, strong	nuclear, strong

Table 1.1: Summarized features of translocations associated with MALT lymphomas. Modified from [201]