

Aus der Klinik für Neonatologie
der Medizinischen Fakultät der Charité – Universitätsmedizin Berlin

DISSERTATION

**The effect of endotracheal tube leakage on the lung protective
mechanical ventilation in neonates**

zur Erlangung des akademischen Grades
Doctor medicinae (Dr. med.)

vorgelegt der Medizinischen Fakultät
Charité – Universitätsmedizin Berlin

von

Ramadan Aboelhasan Ahmed Mahmoud
aus Qena, Ägypten

Gutachter:

1. Priv.-Doz. Dr. sc. G. Schmalisch
2. Prof. Dr. W. Nikischin
3. Prof. Dr. Dr. B. Lachmann

Datum der Promotion: 19.11.2010

Contents

1.	Introduction	1
2.	Respiratory diseases in the neonatal period	4
2.1.	Physiology and pathophysiology of lung development	4
2.1.1.	<i>Pre- and postnatal lung development</i>	4
2.1.2.	<i>Respiratory distress of the newborns</i>	7
2.1.3.	<i>Modern aspects of the management of RDS</i>	10
2.1.4.	<i>Bronchopulmonary dysplasia</i>	12
2.2.	Mechanical ventilatory support in neonates with respiratory diseases	16
2.2.1.	<i>Non-invasive ventilatory supports</i>	16
2.2.2.	<i>Conventional mechanical ventilation</i>	20
2.2.3.	<i>Modern modes of mechanical ventilation</i>	26
2.2.4.	<i>Monitoring of mechanical ventilation</i>	30
2.3.	Patient-equipment interface and air leakages	33
2.3.1.	<i>Air leakages during non-invasive ventilatory support</i>	33
2.3.2.	<i>ET leakages during mechanical ventilation</i>	36
2.4.	Aims of the thesis	38
3.	Material and methods	40
3.1.	In-vitro measurements	40
3.1.1.	<i>Ventilators</i>	40
3.1.2.	<i>Experimental set-up</i>	41
3.1.3.	<i>Simulation of the air leakages</i>	43
3.1.4.	<i>Protocol of in-vitro measurements</i>	44
3.2.	Retrospective clinical study	45
3.2.1.	<i>Patients</i>	45
3.2.2.	<i>Data acquisition</i>	46
3.3.	Statistics	46
3.3.1.	<i>In-vitro study</i>	46
3.3.2.	<i>Retrospective clinical study</i>	47
4.	Results	48

4.1.	In-vitro measurements	48
4.1.1.	Ventilatory measurements	48
4.1.1.1.	<i>Tidal volume measurements</i>	48
4.1.1.2.	<i>ET leakages measurements</i>	48
4.1.1.3.	<i>Effect of ET leakage and respiratory rate on volume error</i>	51
4.1.2.	Measurements of lung mechanics parameters	53
4.1.2.1.	<i>Measurement of lung mechanics in a leakage free system</i>	53
4.1.2.2.	<i>Effect of ET leakage and respiratory rate on compliance measurements</i>	54
4.1.2.3.	<i>Effect of ET leakage and respiratory rate on resistance measurements</i>	56
4.2.	Retrospective clinical study	58
4.2.1.	<i>Patients</i>	58
4.2.2.	<i>Extent of the ET leakages</i>	60
4.2.3.	<i>Influencing factors on ET leakages</i>	62
4.2.4.	<i>Relationship between ET leakages and volume underestimations</i>	64
5.	Discussion	66
5.1.	In-vitro measurements	66
5.1.1.	<i>Air leakage flow and its influence on volume measurements</i>	66
5.1.2.	<i>Tidal volume and ET leakage measurements</i>	68
5.1.3.	<i>Effect of ET leakages on volume errors</i>	70
5.1.4.	<i>Lung mechanics measurements</i>	71
5.1.5.	<i>Limitations of the in-vitro study</i>	73
5.2.	Retrospective clinical study	74
5.2.1.	<i>Patients and data recording</i>	74
5.2.2.	<i>Extent of ET leakages and factors affecting ET leakages</i>	76
5.2.3.	<i>ET leakages and volume underestimation</i>	78
6.	Summary/ Zusammenfassung	81

7.	References list	87
	Curriculum vitae	100
	Selbständigkeitserklärung	104
	Acknowledgements	105

Abbreviations:

A/C	Assisted control
BPD	Bronchopulmonary dysplasia
C	Compliance
CLD	Chronic lung disease
C_{mod}	Compliance of the model
CPAP	Continues positive airway pressure
ELBW	Extremely low birth weight infants
ET	Endotracheal tube
FiO_2	Fraction of inspired oxygen
FRC	Functional residual capacity
G_{leak}	Conductivity of the leak
HFFI	High frequency flow interrupter
HFJV	High frequency jet ventilation
HFNC	Humidified high-flow nasal cannula
HFOV	High frequency oscillatory ventilation
HFV	High frequency ventilation
IMV	Intermittent mandatory ventilation
IPPV	Intermittent positive pressure ventilation,
MAP	Mean airway pressure
MAS	Meconium aspiration syndrome
MMV	Mandatory minute ventilation
N-BiPAP	Nasal bi-level positive airway pressure
nCPAP	Nasal continues positive airway pressure
NEC	Necrotizing enterocolitis
NHFV	Nasal high frequency ventilation
NICU	Neonatal intensive care unit
NIMV	Nasal intermittent mandatory ventilation
NIPPV	Nasal intermittent positive pressure ventilation
NSIMV	Nasal synchronized intermittent mandatory ventilation
NSIPPV	Nasal synchronized intermittent positive pressure ventilation
PAV	Proportional assisted ventilation
PDA	Patent ductus arteriosus

PEEP	Positive end expiratory pressure
PIP	Peak inspiratory pressure
PROM	Premature rupture of membranes
PRVC	Pressure regulated volume control
PSV	Pressure support ventilation
PTV	Patient triggered ventilation
R	Resistance
RDS	Respiratory distress syndrome
R_{ET}	Resistance of the endotracheal tube
$R_{F \text{ sensor}}$	Resistance of the flow sensor
R_{leak}	Resistance of the leak
RR	Respiratory rate
SD	Standard deviation
SIMV	Synchronized intermittent mandatory ventilation
SIPPV	Synchronized intermittent positive pressure ventilation
T_{exp}	Expiratory time
T_{insp}	Inspiratory time
TTN	Transient tachypnea of newborns
VAPS	Volume assured pressure support
VCV	Volume controlled ventilation
VG	Volume guarantee mode
VILI	Ventilator induced lung injury
VLBW	Very low birth weight infant
$V_{leak \text{ exp}}$	Volume which escapes through the leak during expiration
$V_{leak \text{ insp}}$	Volume which escapes through the leak during inspiration
V_T	Tidal volume
$V_{T \text{ exp}}$	Expiratory tidal volume
$V_{T \text{ insp}}$	Inspiratory tidal volume
$V_{T \text{ lung}}$	Tidal volume delivered to the lungs
$V_{T \text{ vent}}$	Tidal volume displayed by the ventilator
VTV	Volume targeted ventilation

1. Introduction

Despite all technological and clinical progress in neonatal care, respiratory disease remains the most common cause of neonatal mortality and morbidity with severe long-term consequences (55) and is responsible for 20% of neonatal deaths (57). Lung development and maturity of the fetus occur mainly during the last weeks of gestation. Therefore, preterm newborns have a high incidence of functional and structural immaturity of the lung (46). Among the respiratory diseases in newborns, respiratory distress syndrome (RDS) is the most frequent. RDS is a multifactorial developmental disease caused by lung immaturity and presents as high permeability alveolar edema, the so called "hyaline membrane". It is characterized by a transient deficiency or dysfunction of alveolar surfactant during the first week of life (82). The published incidences of RDS vary widely. In a study conducted in Switzerland the incidence of RDS in newborn infants was only 0.7% of all inborns and 10.1% of all admitted newborns (55), but its incidence among babies who were born at less than 30 weeks of gestation was up to 50% (148).

Besides prenatal glucocorticoid therapy to enhance lung maturity of neonates (38) and postnatal surfactant therapy (176), invasive and non-invasive ventilatory support remain the most common therapeutic interventions performed in infants with respiratory insufficiency (128). In the past mechanical ventilation via endotracheal (ET) intubation was the standard therapy of RDS. In the USA 1960, about 21 ventilators for neonates were already described (138) and meanwhile different ventilatory types and ventilatory modes are available. During the last few years more gentle non-invasive methods of respiratory support were developed and have become widely used, especially the application of a continuous positive airway pressure (CPAP) (104).

CPAP is a lung protective ventilatory support used for treatment of RDS since it was first described by Gregory et al. in 1971 (75). CPAP stabilizes the airways and improves both pulmonary functional residual capacity (FRC) and lung compliance (153). It also improves both pulmonary and extrapulmonary outcomes by avoiding prolonged mechanical ventilation in premature infants (154). Due to these advantages there have been in the recent years substantial shifts in clinical practice to non-invasive respiratory support, especially nasal CPAP (nCPAP) (153). An essential prerequisite for any non-invasive respiratory support is a sufficient spontaneous breathing effort. If the spontaneous breathing is insufficient then mechanical ventilation is necessary.

For the mechanical ventilation of a newborn different ventilator modes are available. Pressure controlled continuous flow and time cycled intermittent positive pressure ventilation (IPPV) has been the standard modes for neonatal ventilation. Recent advances of the ventilators have provided the practitioner with a variety of new modalities, e.g. synchronized intermittent mandatory ventilation (SIMV), pressure support ventilation (PSV), volume targeted ventilation (VTV) and high frequency ventilation (HFV) (5). Most of the infants who now receive mechanical ventilation are much smaller and more immature than those ventilated 10 years ago (105).

A prerequisite for lung protective mechanical ventilation is the monitoring of the ventilator settings, the tidal volume (V_T) and lung mechanics. This is standard in all modern neonatal ventilators, which allow a continuous and real-time monitoring (23;71;120).

Monitoring has become more accurate and less invasive in recent years and this enhances the care of mechanically ventilated preterm infants (137). The prerequisite is the measurement of airway pressure and flow by special flow sensors, which permit the calculation of the volume signal by integration of the air flow signal. Besides the display of characteristic flow, volume and pressure values and the calculated pulmonary resistance and compliance, a graphical display of flow, pressure and volume waveforms as well as pressure/volume and flow/volume loops allow parameter setting of the ventilator that can provide optimal lung expansion (48). Furthermore, ventilatory monitoring allows the evaluation of the usefulness of medical therapies such as diuretics, bronchodilators and surfactants (17).

Despite the progress in neonatal mechanical ventilation, lung injuries and bronchopulmonary dysplasia (BPD) remain as major morbidity factors with adverse pulmonary and non-pulmonary outcomes in preterm infants. BPD affects more than 40% of infants born prior to 29 weeks of gestation (73). Application of positive pressure ventilation and its duration have a direct effect on the incidence of BPD (149). Complications of mechanical ventilation were a common occurrence such as baro/volutrauma, atelectasis, biotrauma and oxygen-mediated toxic effects. Furthermore lung injury can be caused by an inflammatory response secondary to the stretching and recruitment process of alveoli within mechanical breath (131), air-leak syndromes, subglottic stenosis, tracheal injuries and infection (128). Volutrauma caused by high V_T lead to mechanical alveolar overdistension which in turn lead to a decrease in lung compliance and altered surfactant structure and function (140), but the precise

V_T causing volutrauma is not known and it may be different from patient to patient. However, efforts to limit high V_T appear to be beneficial practice during mechanical ventilation (128). Therefore, optimal ventilatory strategies may permit adequate lung development and prevent ventilator induced lung injuries (VILI) (5).

Regardless of which mechanical support is used, all need an interface: for example, CPAP can be applied by mono- or bi-nasal prongs, face masks or via pharyngeal ET. Irrespective of which interface is used, air leakages occur which may reduce the benefits and cause adverse effects (e.g. impairment of the nasal or upper airway mucosa). Furthermore oral air leakages when using nasal prongs can lead to highly variable flows with unknown effect on CPAP treatment (161).

In mechanically ventilated neonates uncuffed ET were used to protect airways and avoid the occurrence of subglottic stenosis, which occurs in approximately 1 – 2% of incubated neonates (36;171). ET leakages are observed in about 70% of the mechanically ventilated neonatal infants (16). Thus besides V_T and lung mechanics, nearly almost all modern neonatal ventilators also display a value for the ET leakage to inform clinicians about the airtight placement of the ET. There is no linguistic uniformity in the description of ET leakage. In this thesis the term “leak” means a hole and the term “leakage” means the leak flow through this hole.

For the quantification of an ET leakage, different definitions are in use. Besides the direct measurement of the leak flow, an ET leakage is commonly presented in percentages where the leak flow is related to the patient ventilation (161). In most neonatal ventilators the ET leakage is calculated by the difference between inspired and expired V_T and is related to the inspired V_T (117;134). However, clinical interpretation of the displayed leakage is difficult because there is no simple relationship between the size of the leakage and the displayed values (161). Furthermore, most published clinical studies on ventilated newborns do not include information on the extent of ET leakage and how it may affect on the V_T monitoring and lung mechanics parameters. In addition, it is not known how the resulting errors can be interpreted by the clinicians.

Therefore the aim of this thesis is to investigate the relationship between ET leakages and the displayed ventilatory and lung mechanics parameters by an in-vitro study using a mechanical lung model and different ventilators. Furthermore, in a retrospective clinical study using patients’ medical records of mechanically ventilated neonates, the incidence, extent and factor affecting ET leakage in routine clinical practice and the resulting error in the displayed tidal volume will be investigated.

2. Respiratory diseases in the neonatal period

2.1. Physiology and pathophysiology of lung development

2.1.1. Pre- and postnatal lung growth and development

Lung growth and development occur as a series of tightly regulated events commencing in the embryo and continuing post-natal. The ability of the lungs to take over extrauterine gas exchange depends firstly on their morphological structure (113).

The respiratory system develops at around 3 – 4 weeks of embryonic life (100). The respiratory system begins at the nasal cavity and consists of a conducting portion and a respiratory portion. The conducting portion includes the nasal cavity, pharynx, larynx, trachea, bronchi and bronchioles. The respiratory portion consists of the respiratory bronchioles, alveolar ducts, alveolar sacs and the alveoli. Gaseous exchange occurs in the alveoli. The term “acinus” is used to describe the smallest morphological unit for gas exchange. It consists of a terminal bronchiolus, several respiratory bronchioles and six to seven terminal evaginations of the alveolus (187). The development of the respiratory system involves the endoderm and the mesoderm that surrounds it. The early development of the lungs lags behind the development of the heart and great vessels. However, as development proceeds the lungs will eventually occupy more of the thoracic cavity than the heart (32). Five prenatal development stages in the morphological maturation of the lungs can be distinguished (Table 2.1) (100). The boundaries between these stages are not sharp: rather, overlap occurs between various gestational ages and individuals (46). Fetal development of the late air conducting structure occurs mainly in the embryonic and pseudoglandular phases while that of the respiratory structures takes place in canalicular and saccular phases. The mature blood air barrier through which alveolar gas exchange occurs consists of the capillary gas endothelium, a thin cytoplasmic border of type I pneumocytes and a very thin narrow interstitial space which in the narrowest region is formed exclusively by the fused basal membranes of endothelial and epithelial cells. The size of this exchange surface at birth is decisive for optimal postnatal gas exchange (113).

It has been estimated that the number of alveoli at full term birth ranges from 20 – 50 million (100). Alveolar multiplication continues in the postnatal period up until at least the age of 2 – 3 years and alveolar size and surface increases until adolescence period. However, after that, any expansion in the size or surface of the alveoli with increasing age was not significant.

Table 2.1. Stages of lung growth and development according to (46;77;100).

Stage	Fetal age	Lung growth and development
Embryonic	26 days – 7 weeks	Development of major airways (trachea, right and left main bronchi, segmental bronchi).
Pseudoglandular	6 – 16 weeks	Development of airways down to terminal bronchioles, formation of pulmonary arteries and veins.
Canalicular	17 – 26 weeks	Formation of respiratory bronchioles, alveolar ducts, primitive alveoli, differentiation of type I and type II pneumocytes and formation of alveolar capillary barrier.
Saccular	27 – 36 weeks	Increment in gas exchange areas and at the end of this period, the saccular walls contain a double capillary network.
Alveolar	36 weeks – 2 Years Until 18 – 22 Years	Secondary septa appear in the saccular lung to form alveoli. Septation and multiplication of alveoli, enlargement of terminal bronchioles and alveoli.

Normal lung growth and development depends on a number of interrelated prenatal and postnatal factors (109;113;114;151) which are shown in Figure 2.1. The most important prenatal factors are

- embryonic and fetal development,
- genetic constitution (epidermal growth factor, FOXA1, platelet derived factor),
- maternal and fetal nutrition,
- hormonal factors (growth factors and thyroid hormones),
- fetal breathing movements and fetal lung fluid production
- adequate intra- and extrathoracic space,
- environmental factors (tobacco smoking, pollution) and
- intrauterine infection (chorioamnionitis may accelerate lung growth but it also causes lung inflammation and subsequent lung injury).

The most important postnatal factors affecting lung development are:

- preterm delivery,
- surfactant deficiency,
- mechanical ventilation,
- oxygen therapy,
- patent ductus arteriosus (PDA) and
- neonatal septicemia.

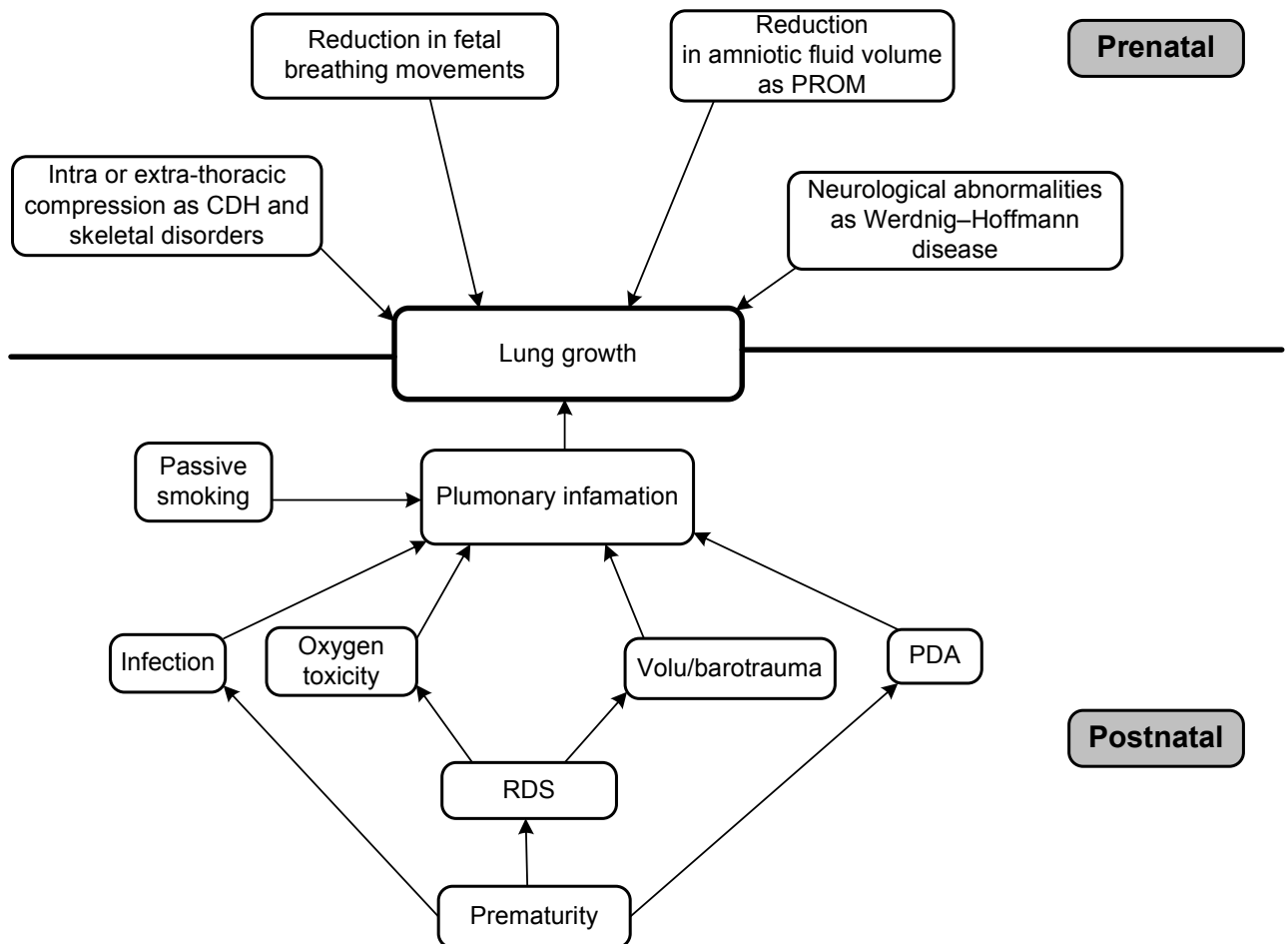

Figure 2.1. Prenatal and postnatal factors adversely affecting lung growth and development (Adapted from (114)). (N.B: CDH, congenital diaphragmatic hernia; PROM, premature rupture of membrane; PDA, Patent ductus arteriosus; RDS respiratory distress syndrome).

However, multiple congenital malformations or diseases associated with abnormal prenatal or postnatal lung development can occur (72;113);

- *embryonic stage*: pulmonary agenesis, tracheal or laryngeal agenesis or stenosis, trachea-malacia, bronchial malformations, arterio-venous malformations and congenital lobar cysts.
- *pseudo-glandular stage*: cystic adenomatoid malformation, pulmonary sequestration, lung hypoplasia, lung cysts and CDH.
- *canalicular stage*: lung hypoplasia, RDS and acinar dysplasia.
- *saccular/alveolar stages*: pulmonary hypoplasia, RDS, BPD, acinar dysplasia and alveolar capillary dysplasia.

2.1.2. Respiratory distress in newborns

Respiratory distress in newborns was defined as the presence of at least two of the following criteria: tachypnea (>60 breaths per minute), central cyanosis in room air, expiratory grunting, subcostal, intercostal or suprasternal retractions and nasal flaring (55). Respiratory distress is still the most common clinical disorder seen in neonates and carries a risk of mortality and morbidity (99). Respiratory distress occurs in approximately 7% of all neonates (87). Infants with respiratory distress persisting for more than 4 h after birth were routinely admitted to a neonatal unit and therefore separated from their mothers (55).

Respiratory distress is caused by a variety of entities of pulmonary and non-pulmonary causes as shown in Table 2.2. The most common causes are RDS, transient tachypnea of newborn (TTN), meconium aspiration syndrome (MAS), pneumonia and pneumothorax (87).

Respiratory distress syndrome, also known as hyaline membrane disease, is a frequently seen acute respiratory disorder in newborn infants (55). The incidence varies inversely with birth weight and gestational age. For birth weights of 500 g – 750 g the incidence was found to be 86%, for 751 g – 1000 g it was 79%, for 1001 g – 1250 g it was 48% and for 1251 g – 1500 g it was 27% (153). Since Avery et al. in 1959 (7) reported the original description of deficiency of the pulmonary surfactant in premature neonates with RDS, there have been remarkable improvements in the care and management of premature infants with RDS (28).

Table 2.2. Causes of respiratory distress in newborns (87).

Pulmonary causes of respiratory distress	Non-pulmonary causes of respiratory distress
<ul style="list-style-type: none"> • RDS • Transient tachypnea of the newborn • Meconium aspiration syndrome • Infection (e.g. pneumonia, sepsis) • Delayed transition of alveolar fluid but respiratory distress is resolved within first few hours of life • Pneumothorax • Pleural effusion • Pulmonary hemorrhages • Persistent pulmonary hypertension • Pulmonary hypoplasia • Congenital emphysema • CDH • Mediastinal masses and cysts 	<ul style="list-style-type: none"> • Congenital heart disease • Neurological disorders such as hydrocephalus, intracranial hemorrhage and ischemia • Metabolic disorders such as hypoglycemia, hypocalcemia, and inborn errors of metabolism • Hematological disorders such as anemia and polycythemia • Esophageal atresia • Macroglossia, teratoma • Lymphangioma • Subglottic stenosis • Laryngotracheomalacia • Choanal atresia, vascular rings • Pierre Robin syndrome

Pathophysiology of RDS is a complex (Figure 2.2) disorder of the premature lung, characterized by biochemical and morphological immaturity. The lack of pulmonary surfactant leads to increased alveolar surface tension and a tendency for alveolar collapse, progressive atelectasis and decreased compliance. The pulmonary histology and cytoarchitectural abnormalities include:

- insufficient alveolarization and a decrease of the surface area available for gas exchange,
- increased distance between the alveolus and its adjacent capillary,
- impaired diffusion of oxygen,
- increased capillary permeability leading to fibrin deposition in the air spaces,
- in some cases excessive muscularization of the pulmonary arterioles resulting in pulmonary hypertension and reduced pulmonary blood flow.

In addition the premature newborn has increased chest wall compliance, which further complicates pulmonary mechanics (13). Clinical diagnosis of RDS depends on the gestational age, symptoms, and signs of respiratory distress. Chest X-rays showing homogenous opaque infiltrates, air bronchograms. Decreased lung volumes can also contribute to diagnosis (55).

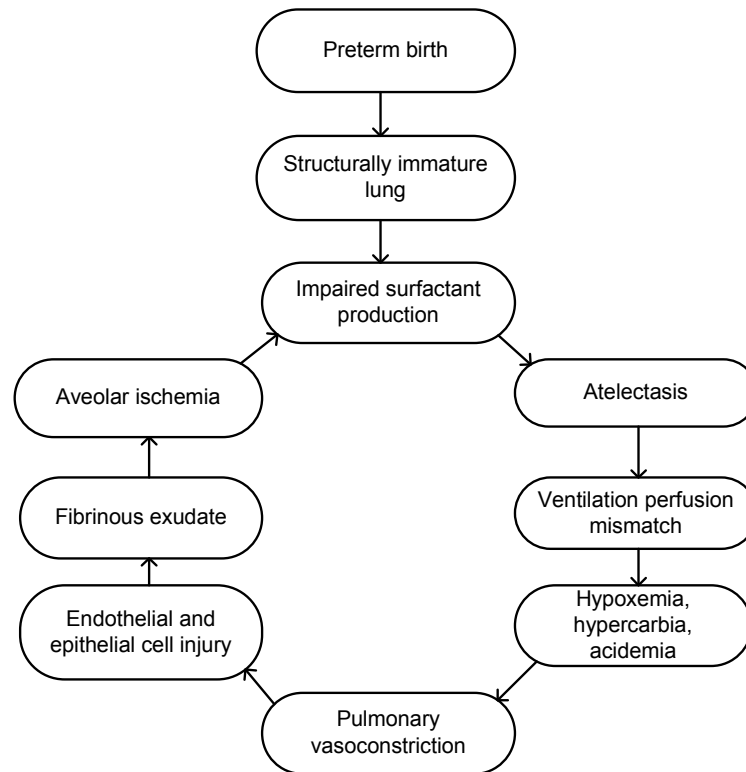

Figure 2.2. Pathogenesis of respiratory distress syndrome (Adapted from (67)).

Transient tachypnea of the newborn (TTN), a clinical syndrome associated with respiratory distress, was first described in 1966 (8). The suggested etiology was delayed lymphatic absorption of the pulmonary alveolar fluid, which distends the alveoli and prevents the non-ventilated lungs from collapsing causing respiratory distress. It is commonly found to occur in term infants and in neonates delivered by cesarean section. TTN is usually a benign and self-limiting disease and the prognosis is generally excellent (101).

Pneumonia was found to be one of the common causes of respiratory distress in neonates. Clinical signs and symptoms were non-specific and did not differentiate between pneumonia and other causes of respiratory distress. Chest X-rays can miss

the diagnosis of pneumonia which had to be corroborated with sepsis screening and blood cultures to confirm the diagnosis (125).

The passage of the meconium from fetal bowels can be seen as a sign of fetal distress in approximately one out of every six births. However inhalation of the meconium, causing meconium aspiration syndrome (MAS), occurs in about one out of six in such births (18). Babies born either at term or at post term have a meconium stained body if the meconium has been present in utero for greater than 3 h. The infant may have meconium staining of the skin, nails and umbilical cord. The anterior – posterior diameter of the chest may be increased if there is significant air trapping. The classic radiographic picture of MAS includes diffuse patchy infiltrates with areas of atelectasis mixed in with areas of hyperinflation throughout the lung fields. However, the chest X-ray may not initially be diagnostic, as it may take many hours for the chemical pneumonitis secondary to MAS to develop. Other findings on X-ray include possible pneumothorax and cardiomegaly if significant perinatal asphyxia has resulted in cardiomyopathy (70). Respiratory failure secondary to MAS remains a major cause of morbidity and mortality in the neonatal population (18). Different ventilation strategies are known and open lung concept was tried in many of animal studies and the results were promising (183)

Pneumothorax, defined as air in the pleural space, can be a cause of respiratory distress when pressure within the pulmonary space exceeds extrapleural pressure. It can occur spontaneously or as a result of infection, MAS, baro/volutrauma or lung deformity. The incidence of spontaneous pneumothorax is 1 – 2% in term births and increases to about 6% in premature births (87). Clinical signs of sudden deterioration of the patients' respiratory support suggest pneumothorax. Urgent chest X-rays will diagnose free air in the pleural cavity (126).

2.1.3. Modern aspects of the management of RDS

The goals of the management of an infant with RDS are to avoid hypoxemia and acidosis, optimize fluid management, reduce metabolic demands, maximize nutrition and minimize lung injury secondary due to baro/volutrauma and oxygen toxicity (87). The most important advances in prevention and treatment of RDS are the use of antenatal glucocorticoids, surfactant replacement therapy, CPAP therapy and new

modes of mechanical ventilation. These have dramatically decreased morbidity and mortality from RDS (116).

Antenatal glucocorticoids accelerate fetal lung maturity by increasing formation and release of surfactant and maturing the lung morphologically. Physiologic stress levels of corticosteroids administered to the mother initiate a receptor mediated induction of specific developmentally-regulated proteins in the fetus (152). Antenatal glucocorticoids also reduce the incidence of intraventricular hemorrhage, which may be secondary to stabilization of cerebral blood flow or maturation of cerebral vasculature (185).

Corticosteroid regimens shown to be effective include betamethasone 12 mg intramuscularly, two doses 24 h apart or dexamethasone 6 mg intramuscularly four doses 12 h apart (24). Corticosteroids were also found to be effective in fetuses between 24 and 34 weeks of gestation and for babies born 1 to 7 days after commencing treatment and combined fetal and neonatal death was reduced even in infants born less than 24 h after the first dose (152). No benefits were demonstrated for treatment of infants born before 24 weeks gestation or for those born more than 7 days after treatment. The use of corticosteroids for babies born after 36 weeks demonstrated a trend of increased combined fetal and neonatal death (24).

For the repeat course of corticosteroid therapy in women who had received a single course of corticosteroids and not delivered in one week of the initial course, while there was evidence of short term respiratory benefits from repeated courses of corticosteroids there was insufficient evidence regarding the potential risks and long-term neurodevelopmental effects to justify the use of repeated doses of corticosteroids in clinical practice (78).

Management of RDS begins with augmented resuscitation in the delivery room. Clinicians commonly had to use ambo-bag resuscitators often with unknown positive inspiratory pressure (PIP) or positive end expiratory pressure (PEEP) applied to the neonate lungs. Now T-piece devices with advance pressure controlled constant flow, FiO_2 , PEEP and PIP can be applied accurately (e.g. Neopuff, Fisher and Paykel Healthcare, Auckland, New Zealand). In one survey, more than 40% of units now used these devices during neonatal resuscitation (94). Furthermore, T-piece devices facilitate the delivery of the desired airway pressure while maximizing the operator's ability to obtain and maintain a patent airway, facilitate the delivery of prolonged inflations, allow for application of surfactants and decrease the need for mechanical ventilation (60).

Surfactant therapy has also been a major contributor to the care of the preterm newborn during the past 25 years. Surfactant therapy reduces both neonatal mortality and pulmonary air leakages by about 50%. The introduction of surfactant therapy was associated with an overall reduction (by about 6%) of infant mortality in the United States of America (81) with a decreased risk of necrotizing enterocolitis (NEC) and resulted in better long-term cerebral outcomes (175).

Surfactant therapy was given to infants with signs of RDS soon after birth reduce mortality and pulmonary complications in ventilated infants (84;184). But second doses may be effective in reducing short-term ventilatory requirements in neonates who have a respiratory decompensation after recovery from initial RDS (21).

Many types of natural surfactants are available in clinical practice today and are proven to be efficacious (175) but the efficacy of synthetic surfactants in large clinical trials still needs to be demonstrated (81). Surfactant administration needs ET intubation and mechanical ventilation as its administration in trials using tracheal installation with a nebulized surfactant have not yet been successful (22). However, Kribs et al. (116) used a combination of nCPAP with early surfactant application by applying surfactant via a thin tracheal catheter without intubation with good results.

In regards to the timing of surfactant application, early surfactant prophylaxis with extubation to nCPAP, called the “INSURE” method (INTubation– SURfactant treatment– Extubation), compared with later selective surfactant replacement and continued mechanical ventilation was associated with a lower need for mechanical ventilation, a lower incidence of BPD, fewer air-leak syndromes and a lower level of treatment with FiO₂ (178).

Adjuvant therapy side-by-side with surfactants and non-invasive and invasive ventilatory therapy (see Chapter 2.2) were necessary to support preterm infants with RDS. Inhaled nitric oxide ameliorates oxygenation and improves respiratory failure in infants who develop persistent pulmonary hypertension (90;190).

2.1.4. Bronchopulmonary dysplasia

Bronchopulmonary dysplasia (BPD), also known as chronic lung disease (CLD) (97), is a chronic lung disease that mainly affects premature babies and contributes to their morbidity and mortality. Improved survival of very immature infants has led to increased numbers of infants with this disorder. This increase puts a heavy burden on health

resources since these infants need frequent re-admission to hospital in the first 2 years after birth (108). BPD was first described by Northway et al. in 1967 as a lung injury in preterm infants resulting from oxygen and mechanical ventilation with persistent respiratory signs and symptoms, the need for supplemental oxygen to treat hypoxemia and an abnormal chest radiograph at 36 weeks postmenstrual age (gestational age plus chronological age) (136). This classic form of BPD with progressive prominent fibro-proliferation has been changed with the introduction of prenatal steroid use, surfactant treatment, new ventilator strategies, aggressive management of the PDA and improved nutrition and other treatments have resulted in major improvements in the clinical course and outcomes of premature newborns with RDS over the past 40 years. Unlike with the original description of the disease, premature infants can develop chronic oxygen dependency without severe RDS: this “new BPD” could be the result of impaired postnatal lung growth (108).

Most infants developing BPD are born prematurely and 75% of affected babies weigh less than 1000 g at birth. The risk of BPD rises with decreasing birth weight: the incidence has been reported as high as 85% in neonates weighing between 500 – 700g, but only 5% in infants with birth weights over 1500 g (108). In total about 30% of low birth weight infants (<1500g) will progress to BPD, characterized by arrested alveolar development and interstitial fibrosis (21). The overall incidence of BPD is reported at about 20% of ventilated newborns (179). Wide variability exists between centers because there are no accepted standards for supplemental oxygen administration and there are also wide variations for its indications among different centers. These have had a marked effect on the reported incidence of BPD (10).

Meanwhile the predisposing factors for BPD, as shown in Figure 2.3, are lung immaturity, which becomes vulnerable to lung injury by oxygen, and ventilator pressure. Invasive mechanical ventilation and its duration have a direct effect on the incidence of BPD (149). The overall concepts of VILI are barotrauma (implying injury caused by pressure), volutrauma (implying injury caused by excessive volume delivered), atelectotrauma (implying injury caused by alveolar collapse) and bio-trauma (the ventilator-induced hyperactivity of inflammatory responses due to decruitment and recruitment of the lungs) (4;51). However recent studies have also suggested an important genetic predisposition (119).

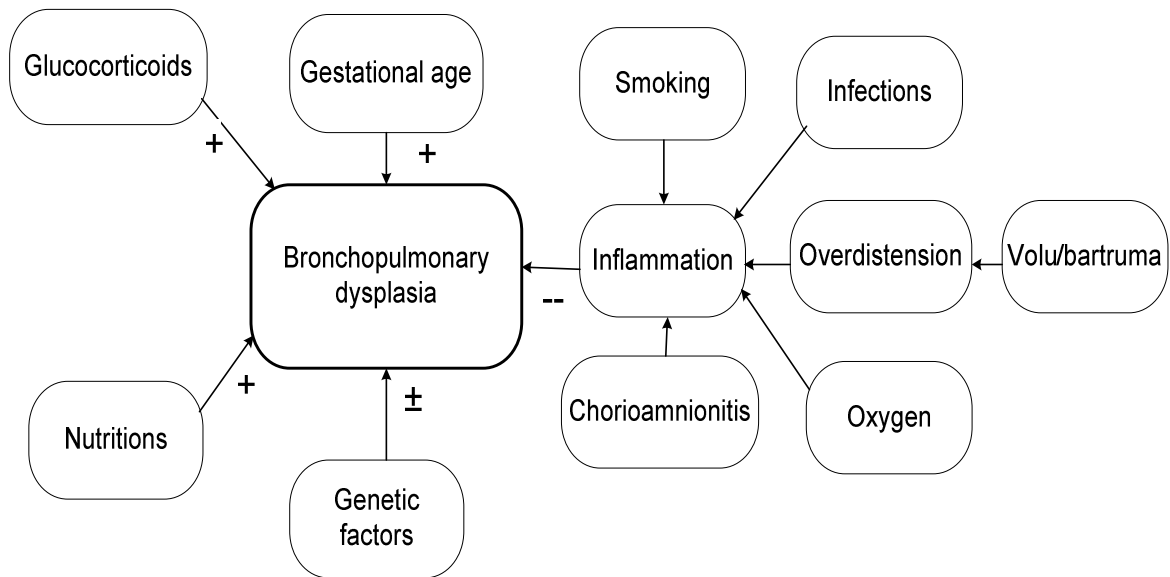

Figure 2.3. Factors affecting the development of BPD. The signs indicate improvement (+) or impairment (-). (Adapted from (43)).

BPD has been classified into mild, moderated and severe forms according to the need of oxygen greater than 21% at 36 weeks postmenstrual age (Table 2.3). Although the disorder is most often associated with premature birth, it can also occur in infants born at term who need aggressive oxygen and ventilator therapy for severe, acute lung disease (108).

However in recent years there has been increasing interest in the prevention of BPD beginning in the resuscitation of preterm infants in the delivery rooms. It has been suggested that the high survival rates and low incidence of BPD experienced in some centers were further improved when nCPAP combined with early surfactant treatment was used (130). This decreased the need for subsequent mechanical ventilation which consider an important outcome when medical resources are limited and may result in less BPD in both developed and developing countries (155).

Nevertheless there are a number of drugs related to strategies for prevention or treatment of BPD. The current evidence for optimal oxygen saturation and avoid hyperoxima in extremely premature infants is associated with better outcomes (180). The use of the lowest dose and shortest course of the least toxic steroid facilitates weaning off the ventilator and protects against BPD. The direct comparison between dexamethasone and hydrocortisone, the available publications on long-term neurodevelopmental outcome provide sufficient evidence to justify a shift from dexamethasone towards hydrocortisone prescription for the treatment of BPD in the

near future (147). Early administration of caffeine citrate seems to confer a benefit with regard to BPD (9). The role of inhalational nitric oxide in the prevention of BPD is still unclear despite existing data from a number of large randomized trials (6).

Table 2.3. Diagnostic criteria for BPD by National Institutes of Health (NIH) (10;108;158).

	Gestational age	
	<32 weeks	>32 weeks
Time-point of assessment	36 weeks postmenstrual age or discharge*	>28 days but <56 days postmenstrual age or discharge*
Treatment with oxygen	>21% for at least 28 days	>21% for at least 28 days
Mild	Breathing room air at 36 weeks postmenstrual age or discharge*	Breathing room air at 56 days postnatal age or discharge*
Moderate	Need for <30% O ₂ at 36 weeks postmenstrual age or discharge*	Need for <30% O ₂ at 56 days postnatal age or discharge*
Severe	Need for >30% O ₂ at 36 weeks postmenstrual age or discharge* with or without positive pressure ventilation or CPAP	Need for >30% O ₂ at 56 days postmenstrual age or discharge* with or without positive pressure ventilation or CPAP
*whichever comes first		

High intramuscular doses of vitamin A slightly reduce the incidence of the disease. There is currently no evidence supporting other drug interventions to prevent BPD as anti-inflammatory drugs (1-proteinase inhibitor, pentoxifylline, cromolyn and azithromycin) and antioxidants drugs (N-acetylcysteine and superoxide dismutase) have not been proven effective yet. Diuretics can ameliorate lung function but there is no evidence supporting their long-term use. Ureaplasma urealyticum colonization of airways is associated with an increased risk of BPD (65). However, there is no proven role for an effect of erythromycin on BPD management (25)

2.2. Mechanical ventilatory support in neonates with respiratory diseases

2.2.1. Non-invasive ventilatory supports

Non-invasive ventilatory supports are used in preterm infants with RDS soon after birth as an alternative to intubation and mechanical ventilation (149) or in those whom are recently extubated. Since CPAP was firstly discovered in 1971 (75) it has been used for many years primarily to treat preterm infants with surfactant deficiency. This has been followed by prospective studies that demonstrated improved survival in premature infants treated with early CPAP (39;98;130). Avoidance of intubation and increased use of CPAP has proven to be an effective strategy for treating RDS. This approach has also been associated with a decreased incidence of BPD (118).

The basic principle of CPAP in neonates consists of a flow driver, humidifier, patient interface and a unit to generate the CPAP. There were different systems in use to generate CPAP for example water bottles (bubble CPAP), spring loaded valves or complex pneumatic pressure regulators (159). The basic principle of bubble CPAP is shown in Figure 2.4. Many commercial CPAP delivery systems were available. Almost all modern neonatal ventilators have the ability to generate CPAP. Furthermore, many exclusive CPAP generator systems are now available in clinical practice such as Infant Flow CPAP system (VIASYS, Conshohocken, PA, USA), Stephan CPAP (Stephan Medizintechnik GmbH, Gackebach, Germany), Bubble CPAP systems (Fisher & Paykel Bubble CPAP) and other self-designed CPAP systems (154).

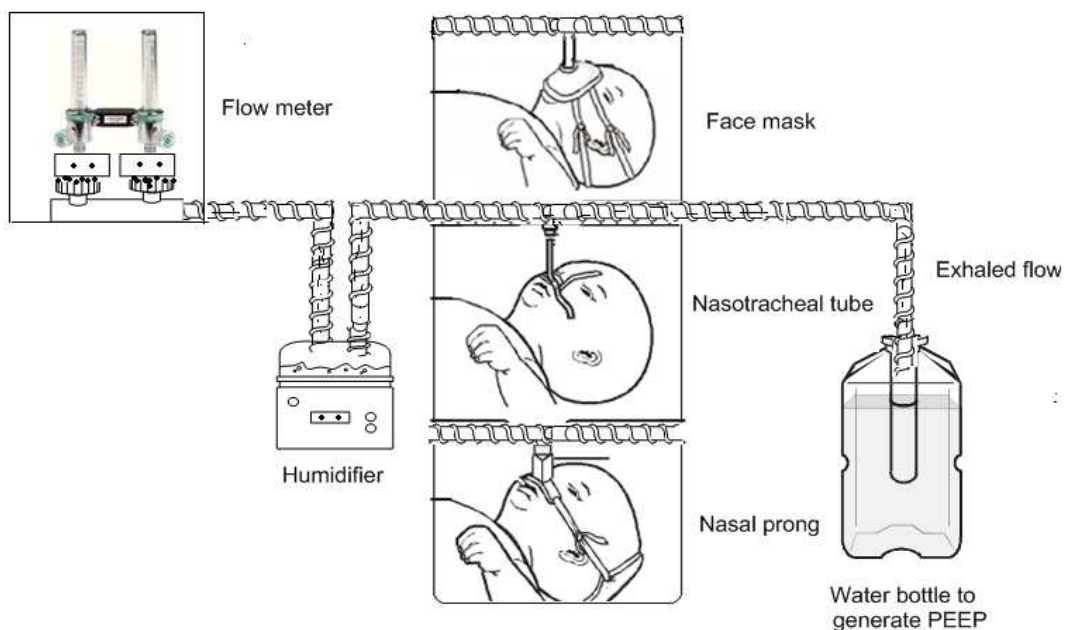

Figure 2.4. Basic principle of bubble-CPAP using different CPAP interfaces.

Moreover CPAP can be provided using constant and variable flow drivers. The constant flow is commonly provided by a ventilator or a flow driver device. The variable flow CPAP is based on the Benveniste principle (15) as used in Infant Flow CPAP. As shown in Figure 2.5 a specially designed nasal adapter device has short nasal prongs with close vicinity to the nares for reducing additional resistance and the nasal adapter produces the CPAP without any inspiratory or expiratory valves. Using fluidic flip technology and the Coanda effect (150) directs the airflow to the infant's airways during inspiration and away from the nares into the expiratory part of the system during expiration facilitating the infant's expiration (110).

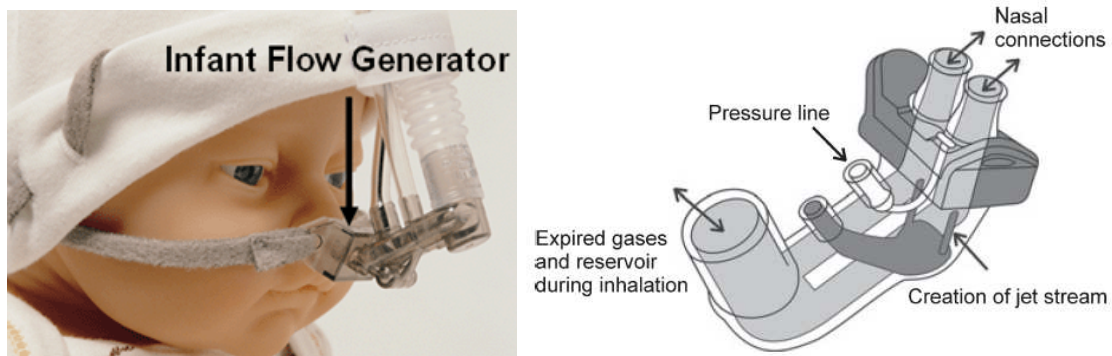

Figure 2.5. Head of the Infant flow generator (Benveniste principle) for delivering nasal CPAP (right) and its application in an infant (left). (Figures from the instructional manual Infant Flow CPAP, EME Trademarks, Brighton, UK)

Physical model studies (110;129) and clinical studies (92) comparing constant flow and variable flow CPAP report a relative decrease in airway pressure variability during breathing with variable flow CPAP. This indicates a potential for superior lung recruitment and maintenance of volume. Moreover, Klausner et al. (110) found that the imposed work of breathing with the variable flow CPAP prongs was one-fourth that of conventional constant flow CPAP prongs. Although the design of the variable flow CPAP prongs allows for an increased gas flow to be diverted away from the patient, it is unclear whether work of breathing is affected (141). But on the other hand in a recent study by Gupta et al. (79), in a randomized controlled trial of post-extubation using bubble CPAP (a continuous flow device) versus Infant Flow CPAP (a variable flow device) in preterm infants with RDS, it was shown that bubble CPAP was associated with a significantly higher rate of successful extubation and a reduced duration of CPAP

support. However, there was no difference in the incidence of BPD or other complications between the two study groups.

Moreover as a practical matter, it is more convenient to use ventilator generated CPAP because it does not require a change of the devices when utilizing mechanical ventilation and CPAP, sometimes for short periods. With mounting evidence that nasal intermittent positive pressure ventilation (NIPPV) may be superior to CPAP alone, there is additional rationale for using ventilator generated CPAP (104).

In a survey in German speaking countries, Röhr et al. (154) showed that the Infant Flow CPAP was used in 32% of the 145 enrolled neonatal intensive care units (NICUs) included in the survey, while the bubble CPAP with constant flow driver was only used in 9%. As shown by Pillow et al. (145) bubble CPAP with the combined effects of CPAP and pressure oscillations from the bubbles provides a lung protective, safe and effective method of respiratory support to spontaneously breathing neonates and may protect from lung injury.

As shown in Figure 2.4 CPAP systems can be applied to the patients using different CPAP interfaces, e.g. a facial mask, head box, mono- or bi-nasal prongs, pharyngeal tube or ET tube. Short bi-nasal prongs (entering both nostrils) are better than single prong nCPAP or nasopharyngeal tube in the treatment of RDS and in reducing the rate of re-intubation for preterm babies. But more research is needed on the best pressure delivery system and the best pressure levels to use (42).

Regardless of which CPAP system is used the main function and physiological effects are (12):

- Increase in functional residual capacity leading to an increase in PaO₂
- Increases pulmonary compliance (provided that there is no over-inflation)
- Increases spontaneous V_T and reduces respiratory effort
- Decrease in alveolar-arterial oxygen pressure gradient
- Prevents alveolar collapse
- Increases airway diameter
- Conserves surfactant
- Splints the airway and diaphragm
- Reduces mechanical obstruction (e.g. by the meconium) improving alveolar recruitment

Several studies have shown that in neonates CPAP decreases the risk of adverse outcomes compared with intubation and mechanical ventilation (39;47;130). Even in mechanically ventilated infants, CPAP reduces the incidence of adverse clinical incidents (apnea, respiratory acidosis and increased oxygen requirements) after extubation (47). Morley et al. (130) compared the use of nCPAP versus intubation in the “COIN” trial (CPAP or Intubation) of very premature infants at the delivery room. Neonates who received nCPAP immediately after birth had a decreased need for oxygen therapy at 28 days of life. They also found that early nCPAP is associated with less surfactant use and less mechanical ventilation exposure, but some increase in the incidence of pneumothorax.

However, CPAP may also have adverse effects. If the lung is over-inflated PCO_2 may increase as V_T decreases and the dead-space fraction may increase. Excessive CPAP may also reduce lung compliance and lead to air-leak syndromes (142). In addition, increasing intra-thoracic pressure may reduce venous return to the right heart and depress cardiac output (1). Also air may escape into the stomach causing gaseous distension (96). The devices used to deliver nCPAP may produce skin excoriation and nasal damage leading to obstruction and risk of infection (189).

Another non-invasive respiratory support is the NIPPV mode that combines nCPAP with superimposed ventilator breaths. It is an accepted mode for weaning infants from mechanical ventilation and for the treatment of apnea in premature newborns (149). It further improves rates of successful extubation and shows promise as an initial method of respiratory support (41). NIPPV is currently used in about 50% of the NICUs in England (139). Furthermore, nasal synchronized intermittent mandatory ventilation (NSIMV) and nasal synchronized intermittent positive pressure ventilation (NSIPPV) are also non-invasive respiratory supports that deliver a synchronized ventilator breath via the nasal prongs. Infants extubated immediately to NSIPPV after surfactant administration were less likely to require re-intubation, had decreased needs for supplemental oxygen during hospitalization and had shorter hospital stays than similar infants who remained on the ventilator following surfactant dosing. Work of breathing has also been shown to be decreased with the use of SNIPPV compared to nCPAP (2). But further studies are needed to compare in detail the differences in effectiveness between NIPPV and NSIPPV in neonates (93).

Moreover Colaizy et al. recently reported (35) the effectiveness of the use of nasal high-frequency ventilation (NHFV) in very low birth weight (VLBW) infants with

respiratory failure. Infants who were receiving nCPAP were switched to NHFV for a two-hour period. Both nCPAP and NHFV were delivered using a single nasopharyngeal tube and the same level of mean pressure as that used during CPAP. PCO_2 was significantly lower after NHFV period, which suggests that nasal ventilation, and specifically NHFV, can improve CO_2 elimination. Further research on the effectiveness and safety of NHFV in sicker patients is necessary before this therapy can be recommended for widespread use (27).

Nasal bi-level positive airway pressure (N-BiPAP) is a non-invasive ventilatory method used successfully in adults (69) and children (3) for the treatment of respiratory failure. During N-BiPAP air and oxygen are continuously sent to the upper respiratory tract at two different levels of positive pressure via a triangular face mask or nasal prong. Migliori et al. (127) found that N-BiPAP, as compared to nCPAP, improved gas exchange in preterm infants and may be helpful in the weaning of unstable patients from mechanical ventilation. The main problem with N-BiPAP is detection of the beginning of breathing, mainly in preterm infants.

One emerging system used nowadays is the humidified high-flow nasal cannula (HFNC) system that has been introduced to neonatal respiratory care as a way to provide positive distending pressure to a neonate with respiratory distress. HFNC therapy aims to maximize patient tolerance by using a heated and humidified gas flow through a standard neonatal nasal cannula (118). Sreenan et al. (177) found HFNC to be as effective as nCPAP in the management of apnea of prematurity. The flow required to generate a comparable positive distending pressure with nasal cannula was about 1 – 3 L/min and varied with the infant's weight.

2.2.2. Conventional mechanical ventilation

Despite a current shift to non-invasive respiratory support in neonates, mechanical ventilation with ET intubation remains an essential tool in the care of critically ill neonates (105). Advances in NICUs and mechanical ventilation over the past 25 years have extended due to the survivability of premature infants to 24 weeks gestation, and occasionally even earlier (52).

Whatever types of ventilators used, either conventional, high frequency ventilation (105), the goals of mechanical ventilation are aimed at overcoming alveolar atelectasis and achieving sufficient lung expansion to facilitate adequate pulmonary gas

exchange, while reducing the infant's work of breathing. This needs to be accomplished without excessive pressure, volume or flow, while maintaining a normal FRC and avoiding atelectasis (51).

Volume controlled ventilators (VCV) (a bellows of defined V_T pumped at a given rate) (Table 2.4) were used in anesthesia, adult and pediatrics intensive care. Until recently, it was only possible to use VCV in relatively bigger babies because of technological limitations in delivering smaller V_T . Recent improvements in the design of certain ventilators have overcome this difficulty, allowing the applications of volume controlled modes to babies weighing even less than 1 kg (e.g. VIP Gold, Bird Products Corp., Palm Springs, CA) (50).

One of the great advantages of VCV is that the primary gas delivery target is V_T and inspiratory pressure is automatically adjusted from breath-to-breath depending on pulmonary compliance. Thus, in conditions with low lung compliance (stiff lungs), more pressure is generated to deliver the desired V_T . As lung compliance improves with resolution of the underlying pulmonary condition, the pressures generated are automatically reduced, which is sometimes referred to as auto-weaning. Unpredictable loss of V_T to gas compression in the circuit and the variable ET leakage around uncuffed ET used in newborn infants makes accurate control of delivered V_T very difficult with traditional volume-controlled modes (105). ET leakage during the inspiratory phase can result in overestimation of the volume measurement and lead to premature termination of the breath (33). Singh et al. (172) demonstrated the feasibility of VCV when special measures are taken to compensate for these problems. In that study, the set V_T was manually adjusted at frequent intervals to achieve a target exhaled V_T measured by a proximal flow sensor at the airway opening. This study showed that VCV is safe and efficacious in VLBW and may decrease the duration of mechanical ventilation and VILI.

In contrast to VCV, pressure-controlled ventilators (pressure-limited, continuous-flow, time-cycled) intermittent positive pressure ventilation (IPPV) have been the standard modes for neonatal ventilation and the most frequently used ventilators in the NICUs (105). The basic principle of pressure-controlled ventilators is shown in Figure 2.6 Pressure limitation means that once the pre-set PIP has been reached, it is maintained for the duration of the inspiratory cycle. Time-cycled implies that breaths are given at fixed intervals, independent of the infant's respiratory efforts. As shown in Figure 2.6 a flow driver generates a constant flow, which was warmed and humidified.

During inspiration, a solenoid valve occludes the expiratory limb so that the gas flow streams via ET in the lungs up until the adjusted PIP is reached. After opening of the valve, the patient exhales via an expiratory limb but a PEEP is applied to prevent alveolar collapse. The main advantage of this mode is the fact that the applied volume in the lung is relatively independent of ET leakage (see Chapter 2.3.2)

IPPV has the advantage of simple, reliable mechanical design and continuous flow permits the infant to easily take spontaneous breaths. Pressure limitation prevents sudden changes in PIP but, with the use of IPPV variable V_T , will deliver to the lung as lung compliance changes. When compliance improves (following surfactant treatment, for example) this may result in over-distension. Also, if the child is exhaling during a non-synchronized ventilator breath, then the breath is ineffective (173).

As the targeted V_T was the same in both the VCV and the IPPV, an explanation for the apparent benefit of VCV needs to be considered. One answer might lie in the way in which flow (and hence volume) is delivered to the lung. During IPPV there is rapid flow delivery resulting in a sharp rise in airway pressure and delivery of volume early in the inspiratory phase. Theoretically, this should favor the expansion of the more compliant areas of the lung, possibly leading to non-homogeneous gas delivery. In VCV there is a slower flow rise but a more sustained inspiratory pressure, with peak volume delivery occurring at the end of the inspiratory phase (172). But on the other hand, IPPV allows several ventilator modes to be applied.

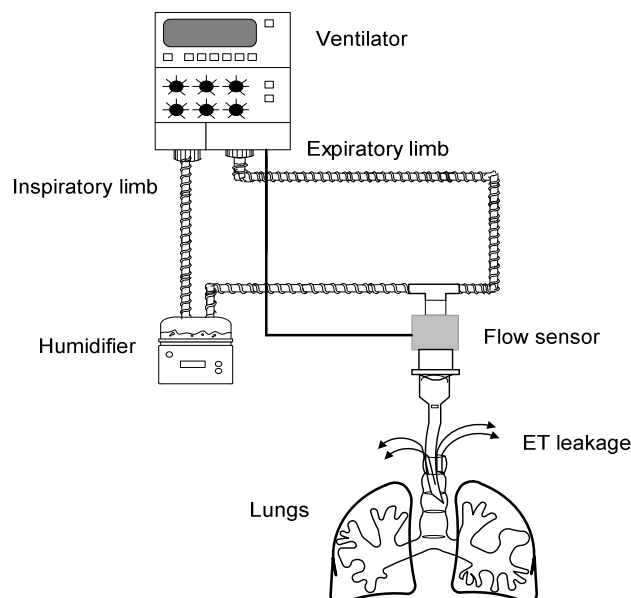

Figure 2.6. Schematic diagram of time-cycled pressure-controlled ventilator with ET leakage.

A synchronized intermittent mandatory ventilation (SIMV) is an example of a pressure ventilator mode. The basic principle of applying the SIMV mode is shown in Table 2.4. The flexibility of SIMV in providing a range of ventilated breaths makes it useful, both as a primary means of ventilator support and as a method for weaning off from ventilatory support (50). Moreover, SIMV is the preferred mode of weaning in many centers. This may be due to a relatively simpler weaning process where the clinician increases the contribution of spontaneous breathing to ventilation by simply reducing the ventilator rate (11).

In SIMV, a trigger was used to detect the time point of the beginning of a spontaneous inspiration and to synchronize it with the beginning of the mechanical breath. After this trigger the breathing cycle is performed according to the adjusted time and pressure values without any influence of the patient on this course. However, spontaneous breaths in excess of the preset number are not supported, resulting in uneven V_T and a potentially high work of breathing, especially during weaning (51). Assisted control (A/C) mode and synchronized intermittent positive pressure ventilation (SIPPV) mode differ from SIMV that every triggered breath is assisted. For example, if the baby is preset to receiving a minimum of 40 breaths/min and the baby breathes at 60 breaths/min then the baby receives 60 assisted breaths if his breathing effort reach the adjusted trigger threshold of the ventilator but the end of the breathing cycle will still be determined by the machine (49). Ventilators in Patient triggered modes (PTV) have an adjustable trigger threshold so that the clinician can compensate for a leakage in the system. If the trigger sensitivity is not set correctly, autocycling may occur (the ventilator misinterprets the leakage, as spontaneous effort by the patient and delivers a mechanical breath) (16).

A/C and SIPPV modes compared with SIMV mode have been documented as having smaller and less variable V_T , less tachypnea, more rapid weaning from mechanical ventilation, smaller fluctuations in blood pressure, reduced air-leak syndromes and a shorter duration of ventilation (74). However, many clinicians still prefer SIMV, especially for weaning from mechanical ventilation. This preference is apparently based on the assumption (unsupported by data) that fewer mechanical breaths are less damaging, as well as on the belief that weaning off from ventilatory rate is necessary prior to extubation

High frequency ventilation (HFV) was first introduced into neonatal practice in the early 1980s, using tidal volumes smaller than the anatomical dead space delivered at a

very high rate, thus avoiding the large volume swings seen with conventional ventilation (37). There are three primary forms of HFV: high frequency jet ventilation (HFJV), high frequency oscillatory ventilation (HFOV) and high frequency flow interrupter (HFFI) as well as other hybrid forms (89).

HFJV uses rates of 240 – 660 breaths/min and T_{insp} are typically about 0.02 s. It is used in tandem with a conventional ventilator, which provides PEEP and optional 'sigh' breaths. High velocity pulsations are injected either at the proximal airway using a special connector or to the distal trachea using a special multiple lumen ET tube. Ventilator adjustments are similar to those with IPPV. The amplitude is set by adjusting PIP and PEEP (51). Keszler et al. (107) reported a reduced incidence of BPD and the need for home oxygen in infants treated with HFJV compared with IPPV for uncomplicated RDS.

HFOV differs from HFJV in that even smaller V_T and active exhalation are used, and rates of 480 – 900 breaths/min (8 – 15 Hz) are generally utilized. HFOV is delivered using a piston pump or an oscillating electromagnetic membrane, which generates true negative pressure during the exhalation phase. Mean airway pressure (MAP) is used to inflate the lung to a static volume and oscillations around this mean are used to affect gas exchange (37;50). Adjustments for oxygenation (via MAP) and ventilation (via amplitude and frequency) are done independently of one another. Gerstmann et al. (68), in a study of 125 neonates of mean birth weight was 1,510g and gestational age 30.9 weeks who received either HFOV or conventional mechanical ventilation demonstrated. There was an increased survival with a decrease in the incidence of BPD in HFOV group, but the trial did not include many very small infants who are the most likely to develop BPD. A randomized trial of 76 neonates of median birth weight 840 g, gestational age 29.3 weeks, reported by Thome et al. (181) showed a shorter time to extubation, however, its endpoint was an evaluation of the inflammatory response and not BPD. A subsequent study by Thome et al. (182) involving 284 infants with gestational age less than 30 weeks found no difference in mortality, intraventricular hemorrhage, inflammatory response or BPD between infants randomized HFOV in comparison to SIMV group.

Table 2.4. Conventional modes of mechanical ventilation in neonates (31;51;172).

Ventilator mode	Mode description
Volume controlled ventilation (VCV)	<ul style="list-style-type: none"> • Constant pre-set V_T with each ventilator breath. • Operator selected V_T and frequency, limitation of PIP and a maximum T_{insp}. • Due to possibility of loss of delivered volume in the ventilator circuit and around uncuffed ET. It is not commonly used in NICUs.
Intermittent positive pressure ventilation (IPPV)/ Intermittent mandatory ventilation (IMV)	<ul style="list-style-type: none"> • Constant pre-set PIP with each ventilator breath. • Operator selected PIP, T_{insp}, required flow and PEEP. • Ventilator delivers the preset PIP and maintained until the end of preset T_{insp} regardless the derived V_T or patient effort.
synchronized intermittent mandatory ventilation (SIMV)	<ul style="list-style-type: none"> • Like IMV but operator also selects maximum sensitivity of the ventilators to detect patient spontaneous breathing • Each time the baby is 'due' to receive a breath the ventilator waits briefly for the infant to initiate a breath. If the baby breathes within this 'timing window' a mechanical breath will be matched to the onset of spontaneous breathing. If the baby fails to breathe, the ventilator will cycle 'on schedule'. • In between triggered mechanical breaths, more spontaneous breathing is only supported by PEEP.
Synchronized intermittent positive pressure ventilation (SIPPV)/ Assisted control (A/C)	<ul style="list-style-type: none"> • Like SIMV but every triggered spontaneous breath is supported by mechanical breaths. • One of the mostly common modes of weaning of neonates from mechanical ventilation.
High frequency ventilation (HFV)	<ul style="list-style-type: none"> • Use of extremely small V_T at rapid rates. • Control of oxygenation (by adjusted mean airway pressure) and CO_2 removal (by adjusted amplitude and frequency) separately.

2.2.3. Modern modes of mechanical ventilation

A survey of current modern modes of mechanical ventilation is shown in Figure 2.7 and Table 2.5. In conventional mechanical ventilation the breathing cycle was defined by the machine according to the adjusted parameter settings and spontaneous breathing movement of the patient was not considered. A mismatch between patient and machine was not uncommon. Modern ventilator modes support the spontaneous breathing of the patient. Pressure support ventilation (PSV) is a new mode of mechanical ventilation which the initiation of mechanical inflation is determined by the beginning of infant's inspiratory effort but in addition, termination of inflation is also determined by the end of infant's inspiratory effort. The exact timing of inflation termination can be fixed, for example with the Babylog 8000 (Draeger Medical, Lübeck, Germany) the inspiration is ended when inspiratory flow declines to 15% of peak flow. In this fashion inspiratory hold is eliminated and the chance of active expiration against positive pressure is minimized, further decreasing asynchrony. PSV may be used alone in a patient who has reliable respiratory drive or as an adjunct to SIMV or volume targeted ventilation modes (52). In recent study by Patel et al. (143) it was shown that the addition of PSV to SIMV during weaning off from mechanical ventilation is associated with a significant reduction in the duration of oxygen supplementation and reduces the work of breathing.

The most recent, and in many ways most promising, advance in neonatal ventilation is the advent of volume targeted ventilation (VTV). The growing recognition that volume, rather than pressure, is the critical determinant of VILI, along with mounting evidence that hypocarbia is associated with neonatal brain injury, has rekindled interest in directly controlling V_T (53). The term VTV refers to modifications of pressure-limited ventilation that adjusts inspiratory pressure and/or time to target a previously set V_T according to the infant weight range from 4 – 8 mL/kg (52).

However ventilator manufacturers have used different strategies to achieve VTV. As a consequence there are differences according to ventilator type in the delivered peak pressure, inflation time, airway pressure waveform and hence MAP during using VTV modes (170).

In the ventilator Babylog 8000, VG option regulates inspiratory pressure in response to changing compliance and patient effort, using exhaled V_T measurement. This approach makes it less susceptible to the effect of ET leakage, but results in some fluctuation of V_T when the patient's respiratory effort is inconsistent. On the other hand, the auto-regulation of inspiratory pressure makes VG a self-weaning mode. Because

weaning occurs in real time, rather than intermittently in response to blood gases, VG has the potential to achieve faster weaning from mechanical ventilation (106). At this point, the only published data are those demonstrating feasibility, greater stability of delivered V_T and less hypocarbia in short-term studies of the VG mode of the Babylog 8000 (30).

However, with the use of VTV mode, the potential major outcome benefits such as reduced mortality, shorter duration of ventilation, decreased risk of intraventricular hemorrhage, periventricular leukomalacia or improvements in outcomes of BPD were demonstrated but proper clinical trials are still needed (103). In regards to BPD, it should be pointed out that avoidance of mechanical ventilation by means of early CPAP, with or without surfactant administration, may still be the most effective way to reduce the risk of BPD (142).

Nevertheless there are many mechanical ventilatory modes that are not fully evaluated as the initial mode of ventilation in preterm infants with respiratory failure. Mandatory minute ventilation (MMV) is a mode that blends features of PSV and SIMV. The clinician chooses a minimum minute ventilation value (the product of V_T and frequency) that the patient is to receive. As long as the patient's own spontaneous breathing with PSV exceeds this level, the patient receives only PSV. However, should the patient's minute ventilation fall below the adjusted minimum, the ventilator will provide "catch up" SIMV breaths to ensure that the patient receives the desired minute ventilation (50).

Moreover, Guthrie et al. (80) studied 20 infants with gestational age >33 weeks that were mechanically ventilated with MMV modes. Neonates with an intact respiratory drive can be successfully managed with MMV without an increase in PCO_2 . The use of MMV mode decreased the number of mechanical breaths and the MAP generated which may reduce the risk of some of the long-term complications associated with mechanical ventilation.

Proportional assisted ventilation (PAV) mode is when the applied ventilator pressure is servo-controlled based on a continuous input from the patient. This input signal alone controls the instantaneous ventilator pressure continuously, virtually without a time lag. The input signal is the modified volume and/or airflow signal of the patient's spontaneous breath. Applying such ventilator pressure waveforms proportionally enhances the effect of the respiratory muscle effort on ventilation. It enables the patient to fully control all variables of breathing. It may offer a way of

reducing the incidence of BPD in low birth weight infants. Although PAV has been extensively studied in small animals with and without lung injury, there are only a small number of published human trials. Schulze et al. (167) undertook a randomized crossover design clinical study comparing PAV to PTV in 22 infants with mean birth weight 705 g and mean gestational age 25.6 weeks who were ventilator-dependent. PAV was found to safely maintain gas exchange at lower mean airway pressures compared with PTV without adverse effects in this population.

Table 2.5. Modern modes of neonatal mechanical ventilation.

Abbreviation	Mode description
Pressure support ventilation (PSV)	<ul style="list-style-type: none"> • Like A/C every spontaneous breath is supported. • Inspiration is ended when the adjusted PIP is delivered. • So that the baby allowed to breath by its own inspiratory effort
Volume targeted ventilation (VTV)	<ul style="list-style-type: none"> • Modifications of pressure limited ventilation that adjusts inspiratory pressure and/or time to target a previously set V_T as VG mode. • Decrease maximum PIP derived to the lung with improvement of compliance
Mandatory minute ventilation (MMV)	<ul style="list-style-type: none"> • This is a combination of PSV and SIMV. • Operator sets the minimum minute ventilation (V_T and frequency). • As long as the patient has sufficient spontaneous breathing effort then he receives only PSV. • If infant's minute ventilation falls below the minimum, the ventilator will provide SIMV breath until the adjusted minute ventilation.
Proportional assisted ventilation (PAV)	<ul style="list-style-type: none"> • This mode depends on the elastic properties of the lung. • The stiffer the patient's lung the more pressure generated. • Not fully studied in preterm infants.

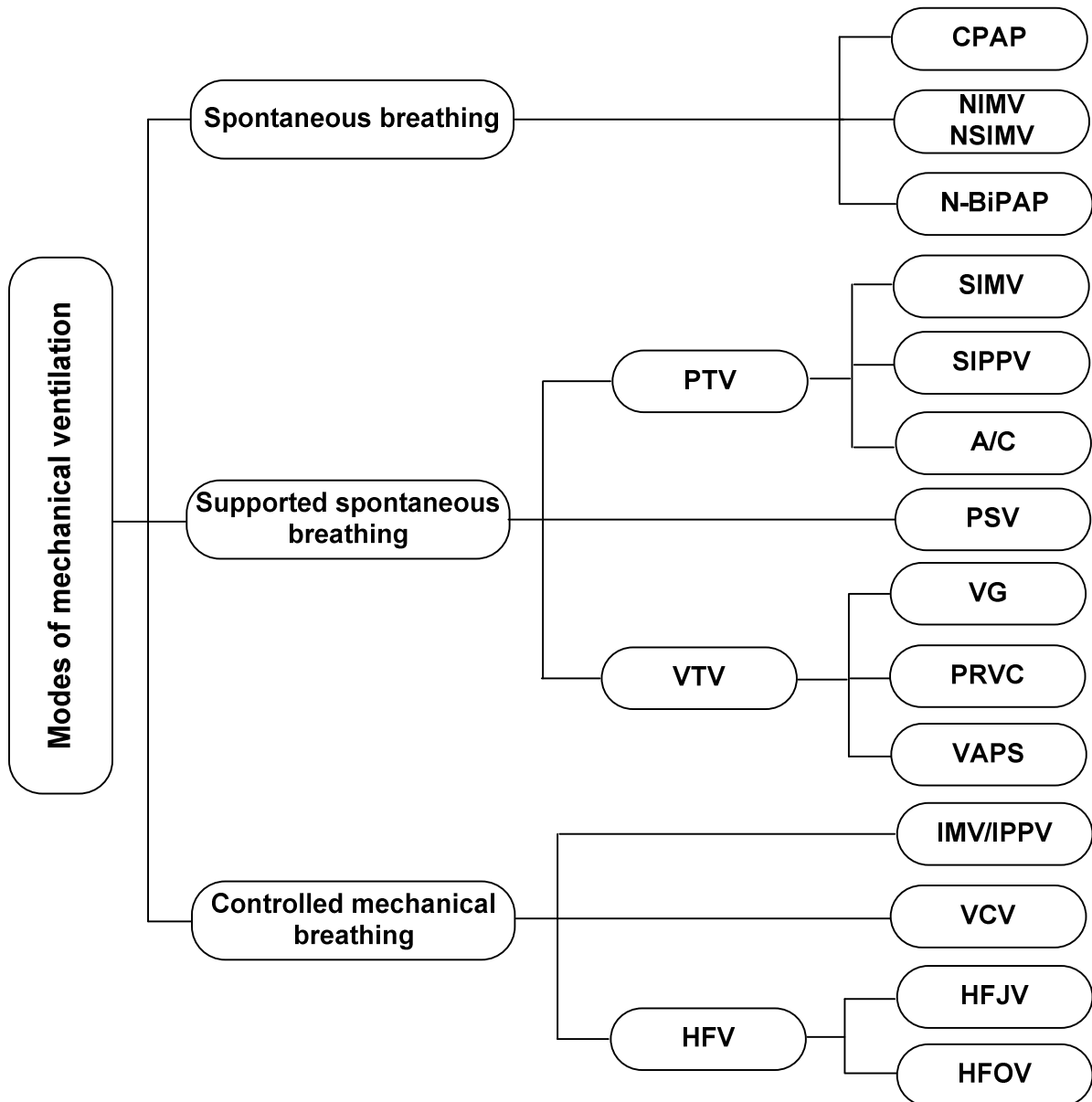

Figure 2.7. Modes of mechanical ventilation considering patient's breathing.

Abbreviations: CPAP- continuous positive airway pressure, IMV- intermittent mandatory ventilation, NIMV- nasal intermittent mandatory ventilation, SIMV- synchronized intermittent mandatory ventilation, NSIMV- nasal synchronized intermittent mandatory ventilation, IPPV- intermittent positive pressure ventilation, SIPPV- synchronized intermittent positive pressure ventilation, PTV- patient triggered ventilation, A/C- assisted control, PSV- pressure support ventilation, MMV- mandatory minute ventilation, N-BiPAP- nasal bi-level positive airway pressure, VTV- volume targeted ventilation, VG- volume guarantee, PRVC- pressure regulated volume control, VAPS- volume assured pressure support, HFV- high frequency ventilation, HFJV- high frequency jet ventilation, HFOV- high frequency oscillatory ventilation, VCV- volume controlled ventilation.

2.2.4. Monitoring of mechanical ventilation

During mechanical ventilation, monitoring aims to improve the safety of the patient and to control the ventilation as shown in Table 2.6. Until recently, clinicians have used observation of chest wall movements and blood gases to guide their choice of rates and pressures to ventilate newborn infants (160). In the 1980s, portable equipment was brought to the bedside and used by specially trained individuals to adjust the ventilator parameters by measuring V_T , compliance and resistance. The principle device used to obtain the ventilation and pulmonary mechanics was a pneumotach sited between the ET and Y-piece of the ventilator circuit. However, this required disconnection and reconnection of the patient from the ventilator, which often disturbed the baby and the gas exchange. In the past the pneumotach was heavy and bulky and if not supported appropriately could change the position of the ET in small infants. Also, it added significant dead space to the baby and increased the work of breathing (14).

Table 2.6. Monitoring during mechanical ventilation.

Patient safety (alarms)	Monitoring
<ul style="list-style-type: none"> • Apnea alarm • Power failure alarm • Minute ventilation • MAP • ET obstruction • Gas disconnection • Ventilator circle disconnection • Inspiratory oxygen concentration • Maximal frequency • Maximal inspiratory time • Inspiratory flow 	<ul style="list-style-type: none"> • Tidal volume • Ventilator pressures (PIP, PEEP, MAP) • Flow/ pressure/ volume signals • Flow/ volume, volume/ pressure loops • Lung mechanics parameters • ET leakage

Today, with enhancement in the technology of neonatal mechanical ventilators, real-time bedside pulmonary graphics have become a standard of care in almost all NICUs. All of the new generation of mechanical ventilators incorporate proximal airway sensors that are positioned between the Y-piece and the ET (137). They are extremely

light and introduce minimal additional dead space. The more common sensor technologies fall into one of two categories: hot-wire anemometer or differential pressure sensor (14). The sensor measures the flow signal and converts the signal to a clinically useful analog value by using a built-in lung-function assessment program in the ventilators (44). This program integrates the flow signal to obtain a volume signal and to measure the percentage of ET leakage.

In addition, the ventilator's software monitor calculates and displays compliance, resistance, V_T , time constant, respiratory rate (RR), minute ventilation, PIP, flow, MAP and PEEP. These allow clinicians to adjust ventilator settings to optimize assisted ventilation (111). The information is presented in real time and is a continuous display, not the snapshot as used in previous pulmonary function technology. The ventilator monitoring is more similar to a "motion picture" of each individual mechanical breath and charts trends of measured values over an extended period of time (14).

Moreover, flow and pressure sensors permit the display of characteristic flow, volume and pressure values and its waveforms versus time as shown in Figure 2.8 (20). Furthermore using two signals means that different breathing loops can be obtained. Pressure/volume loops describe the mechanical properties of the lung as it is filled and emptied (51). It can estimate the dynamic compliance of the respiratory system from the change in volume in relation to the change in pressure and is graphically displayed on the ventilator screen (Figure 2.9) Distortions in the pressure/volume loop may indicate disturbances in lung mechanics. Lung over-inflation occurs when the ventilator delivers volume that exceeds lung capacity, resulting in excess pressure without an increase in volume. A loop that flattens at the upper end, often referred to as a "duck tail" indicates lung over-inflation (14).

The flow/volume loop (Figure 2.9) describes changes in flow and volume over the inspiratory (positive) and expiratory (negative) phases of the respiratory cycle. A normal flow/volume loop should be circular or oval in appearance. This loop allows for inferences regarding resistance to be made. If resistance is high, there will be an impedance to flow, resulting in a smaller volume of gas flow over a constant time (76). Another common finding seen on flow and volume curves as well as pressure/volume and flow/volume loops is the presence of ET leakage (see Chapter 2.3.2).

Despite the major advantages of the current system providing pulmonary mechanics graphics, it should be realized that the information provided about the function of the lungs only complements (and does not substitute) information gained by

other means of patient monitoring, including clinical signs and blood gas examination. Graphics should only be taken as suggestive of a condition rather than being definitive (174). Harikumar et al. (83) compared the reproducibility and accuracy of measurements of compliance and resistance by ventilator flow sensors to the measurements by a single occlusion technique using the pneumotach. They showed that ventilator assessment of compliance, but not resistance, is reproducible and reliable.

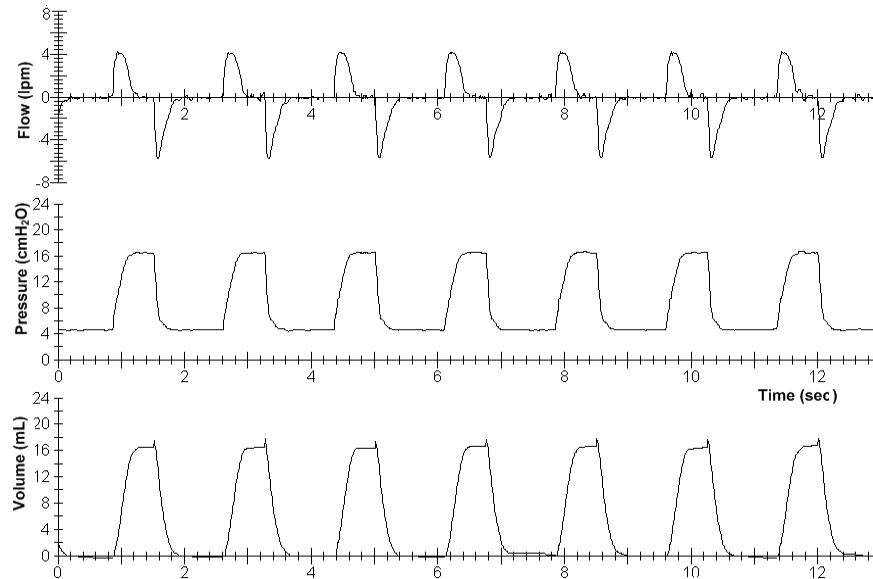

Figure 2.8. Flow (upper panel), pressure (middle panel) and volume (lower panel) wave forms displayed versus time of the intermittent mandatory ventilation (IMV) in absence of ET leakage.

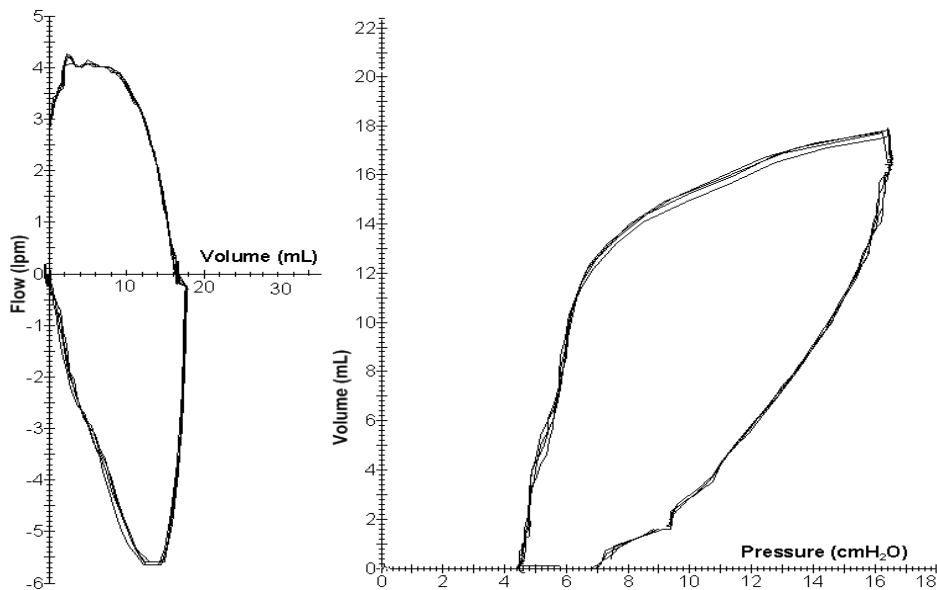

Figure 2.9. Flow/volume (left) and pressure/volume curves (right) in absence of ET leakage measured with CO₂SMO⁺. That the loops are not completely closed is caused by problems in signal processing.

Moreover, pulmonary graphic waveforms can be misshapen because of an inherent inaccuracy in the measurement system (from calibration differences between inspiration and expiration), or from temporary artefacts arising from patient position or gas flow by condensation in the ventilatory circuit. It is imperative to correct these pitfalls before accepting the findings of graphics as a guidance to change ventilatory settings or assess the patient's clinical condition. In this particular respect, the trends over a period of time seem to be of more value than individual breath analysis (174). This may explain why, in a survey of pediatric intensive care units in the UK in ten years ago, only two of the twenty-two responding units used lung-function measurements during extubation from mechanical ventilation (124).

Modern mechanical ventilators are now available with in-built features for estimation of respiratory mechanics, which may mean more widespread use of lung-function measurements in the NICUs (83). Nevertheless, measurements of lung mechanics can provide information about the severity of disease, the response to treatment and the safety of ventilator discontinuation. Mechanics have also become a treatment modality because measuring plateau pressures and making appropriate ventilator adjustments can lead to improved outcomes in selected patients receiving mechanical ventilation (76).

2.3. Patient-equipment interface and air leakages

2.3.1. Air leakages during non-invasive ventilatory support

The effectiveness of non-invasive ventilatory support in the management of neonates with respiratory distress was no longer questioned. However, their widespread use has brought to light the fact that a certain number of patients have unsatisfactory or unsuccessful outcomes with these treatments despite correct application. Air leakages are one of the most common problems that occur independently of the type of ventilatory support used (146). Furthermore, air leakages during CPAP may impair the nasal or upper airway mucosa. An important problem is the air leakage between patient and equipment interface, especially when using lung-function testing. Air leakages at the patient interface impair all measurements of volume and lung mechanics.

There are only a few in-vitro (64;164;168) and in-vivo studies (64;66) which investigated the effect of mask leakages on the measurement of spontaneous breathing in infants. Foitzik et al. (64) developed a method for measuring and correcting air

leakage during lung-function testing in infants by using a flow-through technique which measured the inflow and outflow of a face mask. The method developed was tested in 67 spontaneously breathing infants. The volume was generally underestimated. A leakage-dependent volume error up to 94% could be compensated and numerical corrected to a maximum error of only 5%. Schmidt et al. (164) investigated the effect of mask leakages on the measurement of lung mechanics using the forced oscillation technique. By using computer simulation of air leakages around the face mask or the ET, a significant decrease in the real part and a significant increase in the imaginary part of the respiratory impedance were found.

Air leakages also affect FRC measurements in neonates. In an old study, Fox et al. (66) used a closed circuit helium dilution technique to measure FRC under CPAP. In the presence of air leakage, the error in measurement of FRC was as high as 39% at 3 cm H₂O CPAP and 18% at 0 cm H₂O CPAP. Nevertheless, Seidenberg et al. (168) measured FRC using an open circuit nitrogen washout method in a small-sized lung model. During air leakage, FRC was underestimated with a very strong correlation to the total amount of leakage over the measurement period, which was independent of the ventilatory parameters.

Besides in lung-function testing, air leakages play an important role during non-invasive ventilatory support, especially CPAP, and they are not uncommon (161). Beside the air leakages between patient and CPAP interface, unpredictable leakages can occur via the mouth opening when using nasal CPAP. Furthermore, in preterm neonates air can escape into the stomach causing benign gaseous bowel distension (CPAP belly syndrome) (96), which can mimic variable air leakages. During CPAP the different air leakages impair volume and lung mechanics measurements.

In adults, most modern CPAP devices adjust the background flow in order to maintain a constant CPAP. These devices allow quantitative leakage measurements by flow adjustment, either by a built-in pneumotach of the flow driver or by measuring the rotation speed of the flow generator (157). Such CPAP devices are not available for newborns. In the neonate it is not known to what extent air leakages affect CPAP treatment or how air leakages should be measured and how measuring errors can be corrected (62). Furthermore oral air leakages when using nasal prongs can lead to highly variable flows with unknown effects on CPAP treatment (85).

In neonates, air leaks during CPAP are commonly measured as the leakage flow in relation to the patient breathing flow. Many definitions were used. Schmalisch et al.

(161) compared in an in-vitro study of three air leakage definitions during CPAP given by three formulas.

$$\text{Leakage}_1(\%) = 100 \cdot \frac{V_{T \text{ insp}} - V_{T \text{ exp}}}{V_{T \text{ insp}}} \quad (1)$$

$$\text{Leakage}_2(\%) = 200 \cdot \frac{V_{T \text{ insp}} - V_{T \text{ exp}}}{V_{T \text{ insp}} + V_{T \text{ exp}}} \quad (2)$$

$$\text{Leakage}_3(\%) = 100 \cdot \frac{V_{T \text{ insp}} - V_{T \text{ exp}}}{V_{T \text{ exp}}} \quad (3)$$

Where $V_{T \text{ insp}}$ and $V_{T \text{ exp}}$ are the measured inspired and expired tidal volumes respectively. There were large differences in the results according to the leakage definitions and these differences increased with increasing leakage flow. Furthermore, the effect of RR inversely correlated with the measured leakage, making comparison of displayed leakages between different devices very difficult because the leakage calculation used in the devices is often not described in detail. In another in-vitro study (62) which measured air leakages during CPAP by using a flow sensor between the Y-piece and the ET tube showed that the displayed V_T was underestimated by more than 10% if air leakages exceeded 19% and air leakage of up to 90% of patient flow was reliably detected and corrected.

However, using a flow sensor located between the Y-piece and CPAP interface can only be used for leakage measurements under a mask or single tube CPAP. Unfortunately, in neonates the single tube CPAP interface is commonly used for short period after extubation (154). The bi-nasal CPAP is more frequently used and the volume measurement requires a differential pneumotach, but this technique is far more expensive and measurement is only feasible with custom-made equipment (63). CPAP interfaces based on the Benveniste principle (15) have a defined leakage in the nasal adapter device so that volume measurements are only possible by a face-out whole body plethysmography (54). However such measurements are circumstantial and are limited to research purposes. Moreover, during bubble CPAP, which is commonly used in NICUs, leakage measurements have several technical difficulties, mainly regarding breath detection due to the noisy flow signal (92).

2.3.2. ET leakages during mechanical ventilation

ET leakages, defined as the passage of breathing gas outside the ET, are inherent in neonatal mechanical ventilation as uncuffed tubes are commonly used. ET leakages may be brief or maintained over long periods of time: they may be constant over both inflation and deflation of the lungs, or present over parts of the breathing cycles only (16). ET leakage may affect ventilation negatively when a portion of inflating gas, intended for the lungs, escapes that could lead to inadequate ventilation and numerous errors in ventilatory and lung mechanics measurements. However, ET leakages have also a positive effect by protecting ET' damage to the trachea and vocal cords. Furthermore, ET leakages around trachea can prevent CO₂ re-breathing in mechanically ventilated infants.

Almost all modern neonatal ventilators display a percentage value for the ET leakage and most are calculated by the difference in the inspired and expired volume related to the inspired volume (Equation 1) (117;134). The resulting leakage flow depends on the pressure difference between the inside of the ET and the surrounding pressure, and also on the flow resistance (R_{Leak}) of this opening. In contrast to the CPAP where the pressure is nearly constant, during mechanical ventilation there is a high pressure difference during inspiration and expiration, which affect the leakage flow which impairs both the correction of the ET leakage and its related volume error.

In the past different algorithms were suggested for numerical correction of ET leakage in the measured signals. Wiesemann et al. (188) demonstrated that correction for the ET leakage can be made if the intratracheal pressure is measured during inflation provided the compliance is linear and the inflation flow is held constant. However such corrections, for example for the leakage-dependent volume error, need external signal processing which is not commonly available in clinical settings.

ET leakages do not only affect the displayed inspired and expired volume. They also have a high impact on the quality of the displayed volume curves or loops. ET leakages may also be suspected by looking at the volume waveform, where the expiratory portion fails to reach the baseline (Figure 2.10). ET Leakages could also prevent the normal closure of the pressure/volume loop leaving the expiratory limb to just "hang". On the flow/volume loop the expiratory portion of the loop reaches the volume axis before the origin (Figure 2.11) (14).

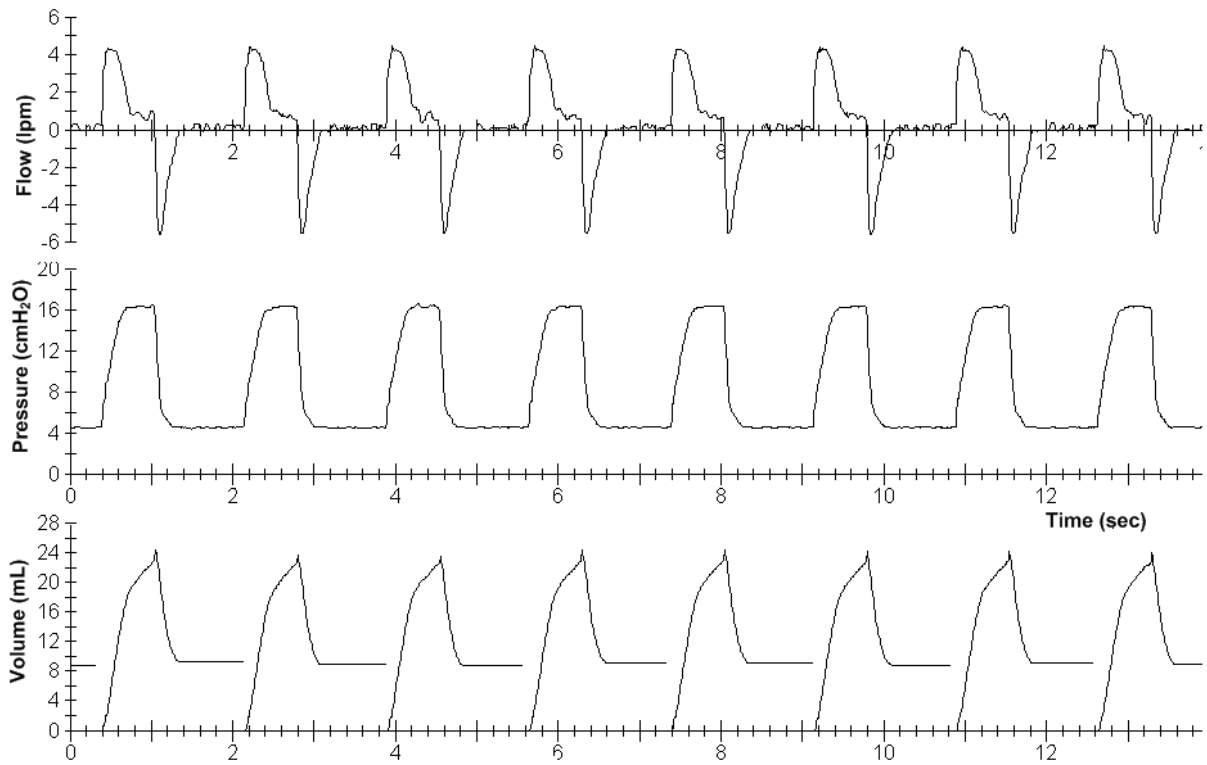

Figure 2.10. Flow (upper panel), pressure (middle panel) and volume (lower panel) waveforms displayed versus time in presence of ET leakage.

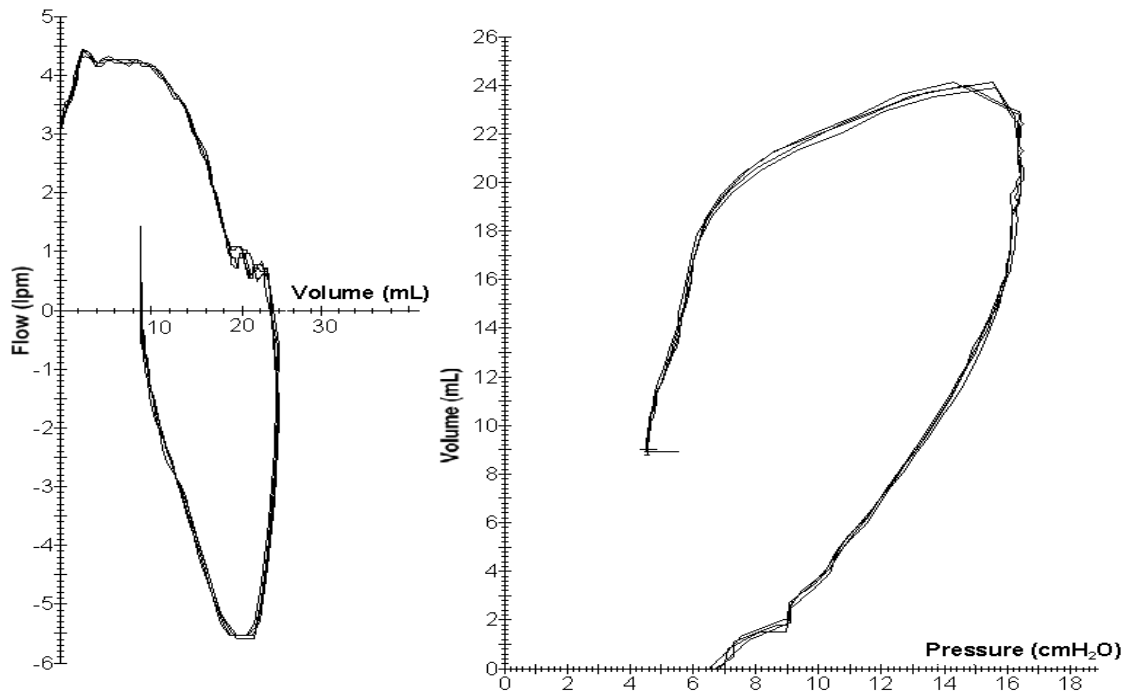

Figure 2.11. Flow/volume (left) and pressure/volume curves (right) in the presence of ET leakage (measured with CO₂SMO⁺ monitor).

2.4. Aims of the thesis

The primary clinical aim of this thesis is the improvement of lung protective mechanical ventilation by the prevention of lung over-distension. Especially in preterm infants, the vulnerable immature lung needs a careful adjustment and monitoring of the V_T . All modern neonatal ventilators permit a continuous volume monitoring, however, this volume monitoring can be misleading in the presence of ET leakages. Due to the used of uncuffed ET tubes, ET leakages are not uncommon and can lead to misinterpretation of the displayed values. To what extent ET leakages affect the volume measurement was investigated in this thesis by in-vitro measurements and by a retrospective clinical study with the following specific aims:

1. In the past several algorithms to measure ET leakages and to correct the resulting errors on ventilation and lung mechanics were developed. However, all these algorithms use measured flow and pressure signals, which are not available for the clinician. The aim of this in-vitro study was to investigate the informative potential of the displayed values of the ventilator for volume adjustment and monitoring, because only this information is available to clinicians.

2. A prerequisite for the in-vitro study was the development of a suitable mechanical lung model to investigate the effect of ET leakages on the measurement of ventilation and lung mechanics. This model was used to investigate:

- the discrepancy between the displayed V_T by the ventilators and the V_T delivered in the lung,
- the influence of the timing parameters of the breathing cycle on the V_T error,
- the effect of ET leakages on the measurement of respiratory compliance and resistance.

3. The relationship between ET leakage and the measured mechanical ventilation parameters and lung mechanics is very complex and it is likely that different algorithms are used in ventilators for measurement and leakage corrections. Therefore the in-vitro investigations were performed with three modern neonatal ventilators, which are widely used in Germany. The aim of these comparative investigations was to determine the ventilator-dependency of the results and clinical recommendations.

4. Only a little is known about the extent and incidence of ET leakages in neonates in the clinical practice. Therefore a retrospective clinical study was performed to analyze ET leakages and V_T using the Babylog 8000 ventilator, which is one of the most commonly used ventilators in Germany. This retrospective clinical study aimed to investigate:

- the extent and incidence of ET leakages in clinical settings,
- the effect of body weight and ET diameter on the ET leakages,
- the within-subject variability of ET leakages,
- the effect of large ET leakages on the volume and pressure settings,
- estimation of the resulting volume errors.

The retrospective clinical study was performed using patients' medical records from NICU of the Faculty of Medicine, Charité University, Berlin. Written parental consent was obtained at admission to our NICU. All parents of infants were fully informed that recorded data were afterwards used for statistical and scientific analysis.

3. Material and methods

3.1. In-vitro measurements

3.1.1. Ventilators

The in-vitro study was performed with three ventilators (Figure 3.1) which are widely used in NICU in Germany:

- 1- Babylog 8000 (Dräger Inc, Lubeck, Germany)
- 2- Leoni (Heinen & Löwenstein, Bad Ems, Germany)
- 3- Stephanie (Stephan Medizintechnik GmbH, Gackebach, Germany).



Babylog 8000 ventilator



Leoni ventilator



Stephanie ventilator

Figure 3.1. Ventilators used for the in-vitro measurements.

All three ventilators could be used for conventional mandatory ventilation, PTV and CPAP in premature babies, neonates and infants. The ventilators were constant-flow, pressure-limited and time-cycled devices which differed in parameter adjustment and display of parameters and signals as described in Chapter 2.2.2. Furthermore, different modern modes of mechanical ventilation could also be applied to these ventilators as described in Chapter 2.2.3 (e.g. SIPPV, PSV, VG).

As shown in Table 3.1 there were no major important differences in the operating and measuring ranges of the three ventilators except for the maximum percentage value of the ET leakage display which for Babylog 8000 was up to 100% but for Leoni only 90%.

The main technical differences between the ventilators consisted in the flow sensor used and the signal evaluation. Babylog 8000 and Leoni used a hot-wire flow sensor sited between the Y-piece and the ET with a very low resistance. Babylog 8000's flow sensor resistance was very low but not specified and the dead space was

0.9 mL, Leoni's flow sensor resistance was also very low (0.078 cmH₂O/L/s) with a dead space of 1 mL while the Stephanie ventilator used a pneumotach as the flow sensor which was also sited between the Y-piece and the ET. The pneumotach had a much higher resistance of 11 cmH₂O/L/s at 5L/min flow and a dead space of 0.9 mL (all data from the manufacturer).

All three ventilators displayed ventilatory parameters (PIP, PEEP, MAP, V_T , T_{insp} , T_{exp}), pressure, flow and volume signals, pressure/volume and pressure/flow loops described in Chapter 2.2.4. However, there were differences in V_T display. Babylog 8000 and Leoni displayed the exhaled tidal volume ($V_{T\ exp}$) whereas Stephanie displayed the inspiratory ($V_{T\ insp}$) and $V_{T\ exp}$. In this thesis only $V_{T\ exp}$ analyzed. The three ventilators displayed the ET leakage in percent calculated by Equation 1 according to the information from the manufacturer.

Table 3.1. Operating and measuring range of the three ventilators.

	Babylog 8000	Leoni	Stephanie
PIP (cmH ₂ O)	10 – 80	6 – 60	5 – 60
PEEP/CPAP (cmH ₂ O)	0 – 25	0 – 20	0 – 30
Respiratory rate (breaths/min)	1 – 200	2 – 300	0 – 300
Fraction inspiratory oxygen (Fio ₂ %)	21 – 100	21 – 100	21 – 100
Inspiratory time (sec)	0.1 – 2	0.1 – 2	0.1 – 2
Expiratory time (sec)	0.2 – 30	0.2 – 30	0.1 – 60
Inspiratory flow (L/min)	1 – 30	1 – 30	1 – 30
V_T (mL)	2 – 100	0 – 999	2 – 150
ET leakage (%)	0 – 100.	0 – 90	Not specified
Trigger volume (L)	1 – 10	1 – 10	1 – 10

3.1.2. Experimental set-up

The effect of ET leakage on the volume measurement was investigated using an experimental set-up shown in Figure 3.2. The ventilators were used in the same way as

for clinical application, except no humidifier was used to prevent measurement errors due to water condensation.

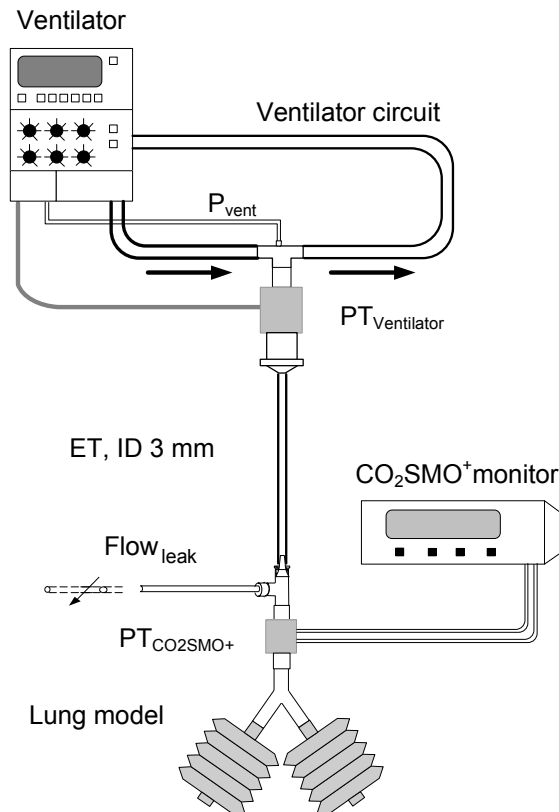

Figure 3.2. Schematic diagram of the experimental set-up used to investigate the effect of ET leakage on volume measurement.

As shown in Figure 3.2 a custom-made neonatal lung model consisting of two silicon bellows (Dräger Inc, Lubeck, Germany) was ventilated via a 3 mm ET (Portex, Smiths Medical Watford, UK) and a length of 15 cm – the most frequent used ET in our NICU. The pressure volume characteristic of the silicone bellows is shown in Figure 3.3. The static pressure volume curve was slightly non-linear so that the compliance depended on the pressure range used. For the given PIP and PEEP used in the in-vitro study the corresponding compliance was 1.3 mL/cmH₂O. The resistance of the ET increased linearly with the flow (Figure 3.3). For a variable flow during the breathing cycle no valid value could be obtained. However, if the measuring conditions were constant the measured resistance between the ventilators could be compared.

Moreover, V_T was measured by the ventilator at the Y-piece and after the simulated ET leakage by a additional pneumotach using the CO₂SMO⁺ monitor (Novamatrix Medical Systems, Wallingford, CT) so that the actual true volume which

was delivered to the lung model could be measured (Figure 3.2). The CO₂SMO+ used a low resistance pneumotach for flow and volume measurements and the dead space was less than 0.5 mL. Routine calibration was not required during the measurements. The CO₂SMO+ performed a zero adjustment automatically.

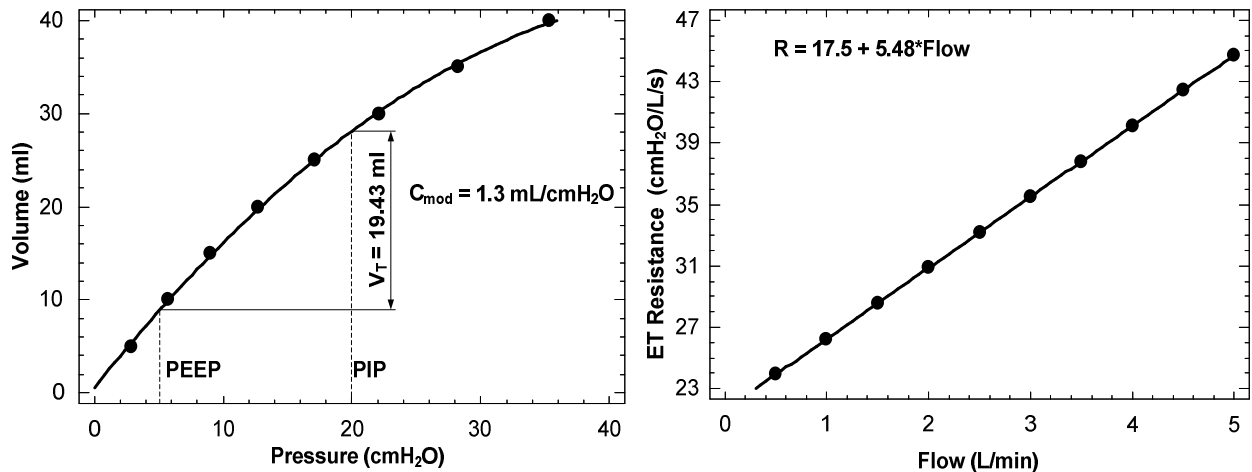

Figure 3.3. The volume/pressure curve of the model (left) and the corresponding compliance in the investigated pressure range. The resistance of the ET tube used and its dependence on the flow (right) described by the regression equation.

3.1.3. Simulation of the air leakages

ET leakages were simulated by open silicone tubes (inner diameter 1.5 mm) of variable lengths (Table 3.2) attached between the ET and the lung model (Figure 3.2). The resistance of the silicon tubes was determined using a constant flow of 0.5 L/min adjusted by a laboratory Rotameter (Aalborg Instruments and Controls Inc., Orangeburg, USA) and the measurement of the pressure drop across the tube by Digital Manometer (Revue Thommen AG, Waldenburg, Switzerland). The resistances were then calculated by the pressure/flow quotient. There was a strong linear relationship between the tube length and the measured tube resistance as shown in Figure 3.3.

No leakage means an infinity high tube resistance (R_{leak}). Unfortunately this was not suitable for graphical representation of the effect of ET leakage on the measured parameters. Therefore the leak conductivity (G_{leak}), i.e. the reciprocal value of the R_{leak} was calculated and used in the graphics. Thus, if there was no leakage G_{leak} is zero and all curves start at the zero point.

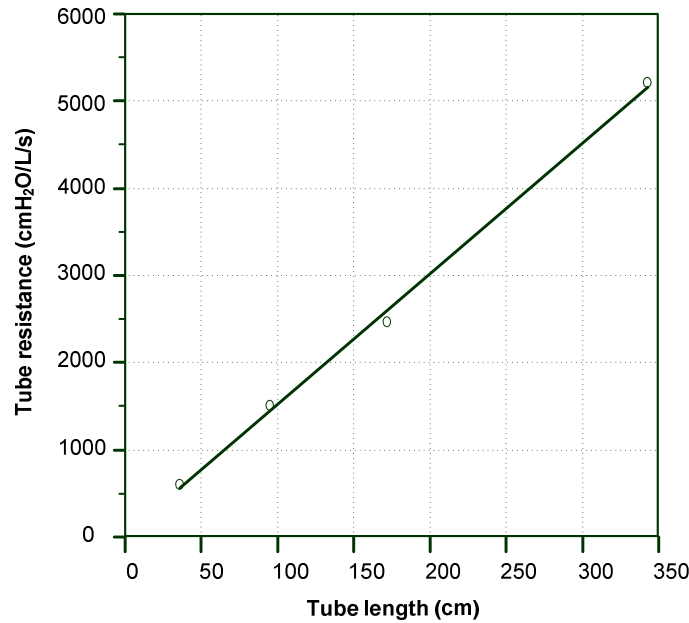

Figure 3.3. Relationship between length and resistance of the silicone tubes.

Table 3.2. Characterization of simulated ET leakages using different lengths of open silicon tubes. Leak resistance (R_{leak}) and leak conductivity (G_{leak}) values of the tubes were measured at a flow rate of 0.5 L/min.

Leak	Tube length (cm)	R_{leak} (cmH ₂ O/L/s)	G_{leak} (mL/s/cmH ₂ O)
No leak			0.0
Leak 1	343	5205	0.19
Leak 2	172	2460	0.41
Leak 3	95	1503	0.67
Leak 4	36	598	1.67

3.1.4. Protocol of in-vitro measurements

In-vitro experiments were carried out in the Infant Lung Function Laboratory, Department of Neonatology, Charité Universitätsmedizin Berlin, Campus Mitte. All measurements were taken in air conditioned rooms (room temperature: 24.4 ± 1.46 °C, room humidity: $63.7 \pm 1.9\%$, barometric pressure: 756 ± 0.42 mmHg). All flow sensors of the ventilators used were calibrated before each study according to the manufacturers' instructions.

For each ventilator the measurements were started without leakage and RR of the ventilator was varied between 20 breaths/min and 70 breaths/min while all other parameters were kept constant (flow 6 L/min, PIP 20 cmH₂O, PEEP 5 cmH₂O, and T_{insp}:T_{exp} 1:1). Following that tubes of decreasing length and resistance were subsequently attached and RR was varied in the same way. Each series of leakage measurements was repeated five times.

To prevent any effect of water condensation in the flow sensor and tubes, all measurements were performed using room air. Before each series of measurements a warm-up time of at least 30 min was allowed. After parameter change at least 5 min was permitted to elapse before new values were recorded.

3.2. Retrospective clinical study

3.2.1. Patients

In this retrospective study, patient records of all mechanically ventilated neonates treated from August 2006 to December 2008 in the NICU of the Department of Neonatology, Charité Universitätsmedizin Berlin, Campus Mitte, were evaluated. Inclusion criteria were mechanical ventilation using synchronized or unsynchronized intermittent positive pressure ventilation (IPPV or SIMV/SIPPV) delivered by the Babylog 8000 for ≥ 5 h. Exclusion criteria were mechanical ventilation employing other ventilators or other ventilator modes. As already described Babylog 8000 ventilator displayed $V_{T\text{ exp}}$ and calculated the ET leakage according Equation 1. According to our NICU protocol, the size of ET for intubations was determined by the commonly used weight-based method recommended in the Neonatal Resuscitation Program (body weight <1000 g tube size 2.5 mm, body weight 1000 – 2000 g; tube size 3 mm, body weight 2000 – 3000 g; tube size 3.5 mm, and body weight 3000 – 4000 g; tube size 3.5 mm – 5mm) (102) with the exception that in infants <600 g ET tubes with 2mm were used if the intubation with 2.5 mm ET tubes failed. Moreover, the length of the ET tube from mouth to trachea was estimated by the 7, 8, 9 rule method (length of ET in cm= weight in Kg plus 6) so that if the infant weighted 1Kg then the depth of ET was 7 cm (144) and added 1cm if nasal intubations was preformed then the placement of the ET tube was confirmed by X-ray film.

3.2.2. Data acquisition

Infants meeting the inclusion criteria were identified from the archive of patient medical records and patient characteristics (body weight, gestational age, indication for mechanical ventilation, age at commencement of ventilation, duration of ventilation and number of re-intubations and mechanical ventilation) were recorded. Ventilator settings, ET leakage and V_T were recorded routinely every 3 h by the nurses and revised regularly by physicians. However, if any changes in the displayed data were occurred due to (e.g., changes in ventilatory settings, ventilator disconnection, suction, re-intubation) within the recording period, these changes were recorded at occurrence after a stabilization period of at least 5 minutes. The recorded values represent a mean value over an observation window of about 30s.

Infants who showed at least one ET leakage episode greater than 5%, which is the lowest reliable measured ET leakage by the Babylog 8000 (122), were identified. Using data from these infants, parameters of mechanical ventilation (ventilator settings, ET leakage, V_T , and ET tube used) were recorded at three time-points:

- The first time-point was the day on which ET leakage first occurred.
- The second time-point was the day on which the highest ET leakage was seen.
- The third time-point was the day of extubation.

Within 24 h of each of these time-points the lowest, median and highest ET leakage values, V_T and the corresponding ventilator settings and sizes of ET tubes were determined. If a child was ventilated more than once then the longest period of mechanical ventilation were analyzed and the last day of this period was used as the day of extubation.

3.3. Statistics

3.3.1. In-vitro study

All data presented in the text and figures are means with standard deviation (SD). The co-efficient of variation (CV [%] = $100 \cdot \text{SD} / \text{mean}$) was calculated to describe reproducibility of measurements and described by the median and range of five repeated measurements. The effects of simulated leakage and RR on displayed volumes and leakages were investigated by multivariate analysis of variance (MANOVA). Statistical evaluations were performed using the software STATGRAPHICS (Vers. 5.0, Manugistics Inc., Rockville, MD). A value $p < 0.05$ was considered to reflect statistical significance.

3.3.2. *Retrospective clinical study*

Qualitative parameters were compared between patient groups using the chi-squared test or Fisher's exact test, as appropriate. Patient characteristics, duration of mechanical ventilation, ET leakage and V_T related to body weight are presented as medians with ranges and were evaluated for significance by the Mann-Whitney rank test. Ventilator settings for neonates with ET leakage presented as mean (SD) values were compared by ANOVA for repeated measurements. Linear regression analysis is used to investigate the relationship between within-subject changes in the displayed leakage and tidal volume. Spearman rank correlation was employed to investigate the effect of patient characteristics and ventilator settings on leakage extent. Statistical evaluations were performed using Statgraphics Centurion software (Version 15.0; Statpoint Inc., Herndon, VA) and GraphPad PRISM (Vers. 4. San Diego, California, USA). A p value <0.05 was considered to reflect statistical significance.

4. Results

4.1. In-vitro measurements

4.1.1 Ventilatory measurements

4.1.1.1. Tidal volume measurements

For the three investigated ventilators the tidal volume delivered in the lung ($V_{T \text{ Lung}}$) significantly decreased both with increasing RR and ET leakage ($p < 0.001$), but the changes were very small. Increasing RR decreased $V_{T \text{ Lung}}$ about 3% (Babylog 8000), 1.5% (Leonie), and 1.5% (Stephanie), respectively. For Babylog 8000, Leoni, and Stephanie, $V_{T \text{ Lung}}$ decreased with increasing leakage (Figure 4.1) by about $0 \pm 0.25\%$, $2 \pm 0.05\%$, and $5.6 \pm 0.28\%$, respectively.

In the absence of an ET leakage there was a ventilator-dependent systematic bias between the tidal volume displayed by the ventilator ($V_{T \text{ vent}}$) and $V_{T \text{ lung}}$ (Babylog 8000, $2.5 \pm 0.18 \text{ mL}$; Leoni, $-0.52 \pm 0.3 \text{ mL}$; Stephanie, $0.14 \pm 0.21 \text{ mL}$) which was numerically corrected in all measurements. Therefore, all start points of $V_{T \text{ vent}}$ and $V_{T \text{ lung}}$ are identical in Figure 4.1.

In contrast to $V_{T \text{ Lung}}$, the displayed $V_{T \text{ vent}}$ significantly decreased with increasing ET leakage as shown in Figure 4.1. There were statistically significant differences ($p < 0.001$) between the ventilators. For the highest simulated leakage (Leak 4) the volume errors for Babylog 8000, Leoni and Stephanie were $21 \pm 0.7\%$, $30 \pm 1.1\%$, and $33 \pm 3.3\%$, respectively. The volume measurements were highly reproducible. Coefficients of variation were $< 1.1\%$ for Babylog 8000, $< 3.5\%$ for Leoni, and $< 4.3\%$ for Stephanie.

4.1.1.2. ET leakages measurements

In contrast to $V_{T \text{ vent}}$, the displayed ET leakage was highly dependent on the timing parameters of the breathing cycle. As shown in Figure 4.2 the displayed leakages increased with rising T_{insp} and leak size in all three ventilators. With increasing leak size the time-dependence of the displayed leakage increased. In the RR range between 20 breaths/min and 70 breaths/min for Leak 4, the displayed leakage varied from $42.6 \pm 0.54\%$ to $76.8 \pm 0.44\%$ for Babylog 8000, $44.6 \pm 0.54\%$ to $75.6 \pm 0.89\%$ for Leoni and $12.8 \pm 0.44\%$ to $44.6 \pm 0.54\%$ for Stephanie.

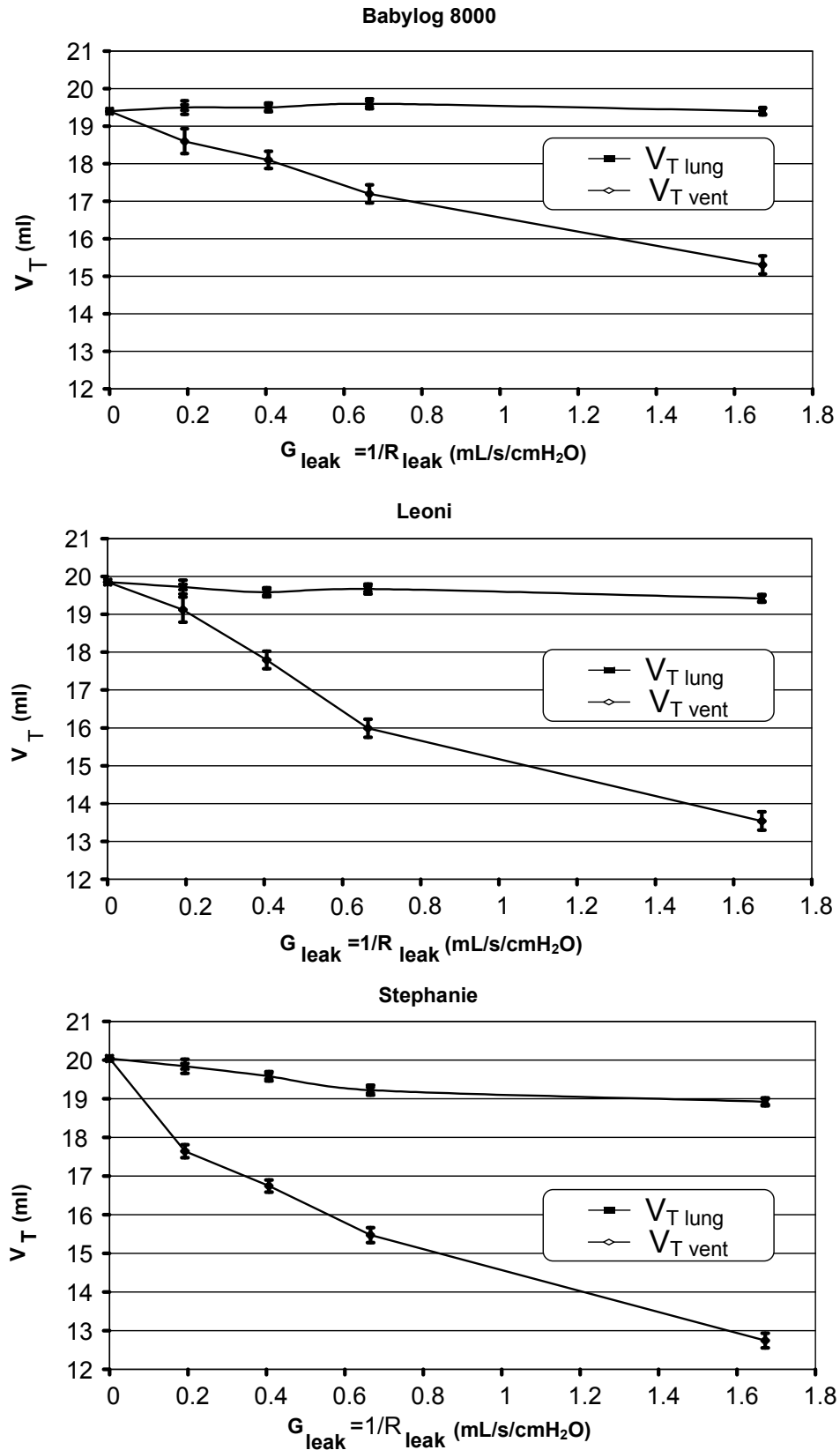

Figure 4.1. Comparison of the measured $V_{T\ lung}$ (by CO₂SMO⁺monitor) and the displayed $V_{T\ vent}$ (by ventilator) of the three investigated ventilators in relation to ET leakage conductivity (G_{leak}).

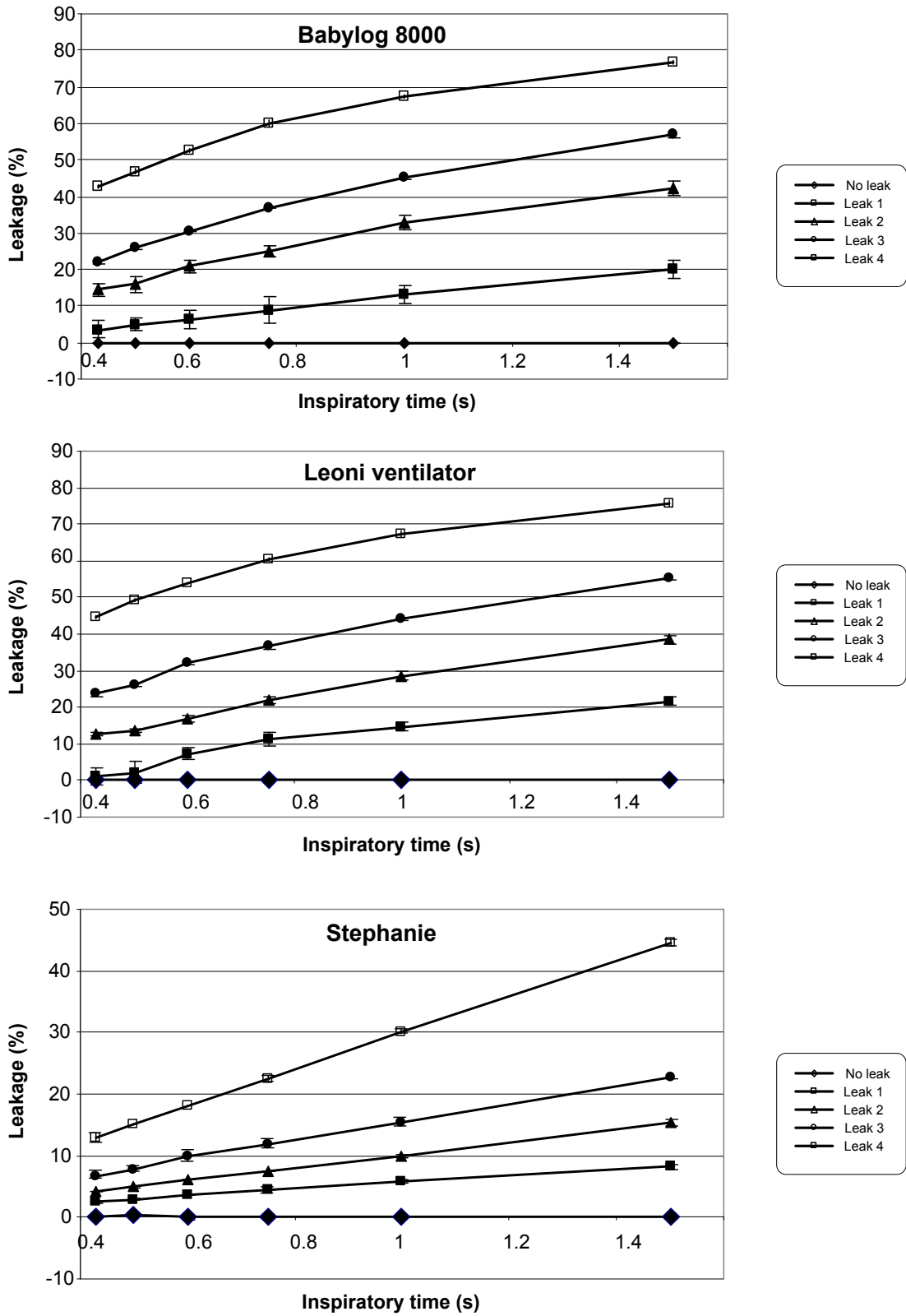

Figure 4.2. Comparison of displayed ET leakages of the three ventilators, and relationships between these values on the one hand, and both leakage flow and inspiratory time on the other.

At an RR of 30 breaths/min the dependency of the displayed leakage value on the size of the leak (leak conductivity) is shown in Figure 4.3. There was no statistically significant difference between Babylog 8000 and Leoni, whereas the leakage displayed by Stephanie was about half that of the other ventilators.

The median (range) of coefficients of variation of all leakage measurements were for Babylog 8000 1.75% (0 – 9.8%), for Leoni 0.7% (0 – 9.2%) and for Stephanie 0.04% (0 – 6.2%).

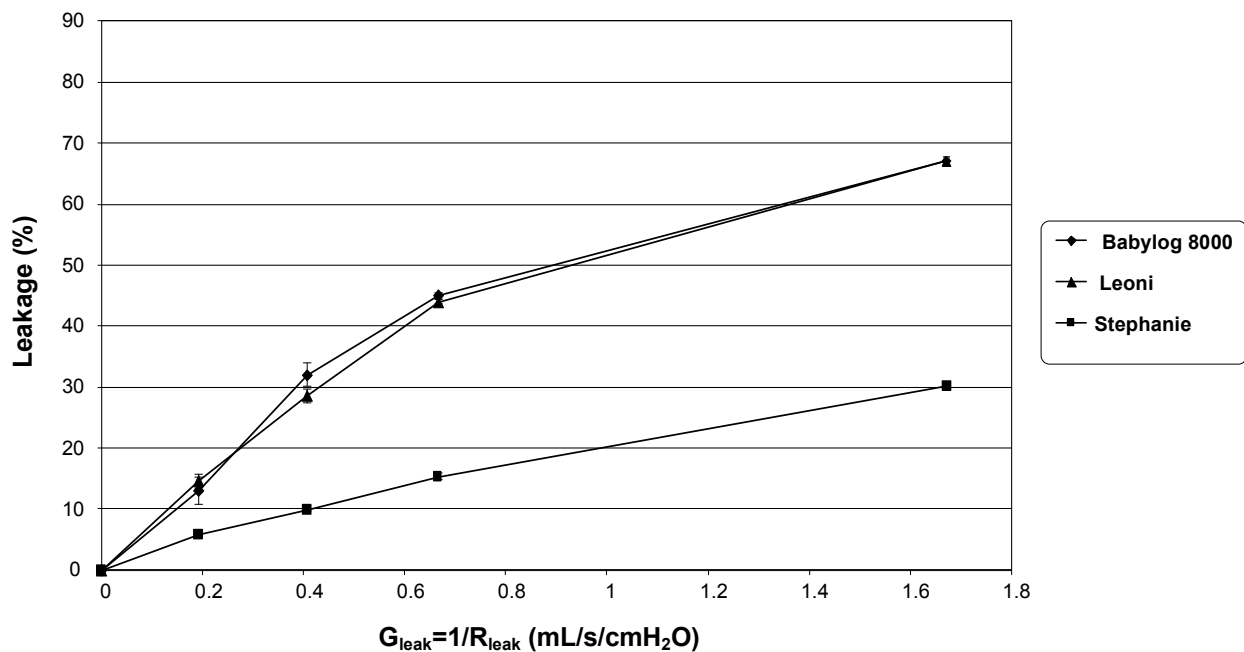

Figure 4.3. Displayed leakage as a function of ET leakage conductivity (G_{leak}) for the three ventilators, at a respiratory rate of 30 breaths/min.

4.1.1.3. Effect of ET leakage and respiratory rate on volume error

The relationships between errors due to underestimation of the displayed $V_{T\ vent}$ and displayed leakage are shown in Figure 4.4. At a constant RR, the volume error increased with increasing leakage in all three ventilators, but the relationships between these parameters differed significantly between ventilators. If volume errors of <10% are viewed as tolerable, then leakages of up to 20% in the Babylog 8000, 12% in Leoni, and 5% in Stephanie are acceptable.

Furthermore, the relationship between volume error and displayed leakage is hampered by the dependence of displayed leakage on timing parameters. For example, for an RR of 20 breaths/min, the displayed leakage was associated with a small volume error whereas the same displayed leakage at an RR of 70 breaths/min was associated

with a high volume error (vertical scatter in Figure 4.4). On the other hand, for the same volume error the displayed leakage can vary significantly depending on RR (horizontal scatter in Figure 4.4).

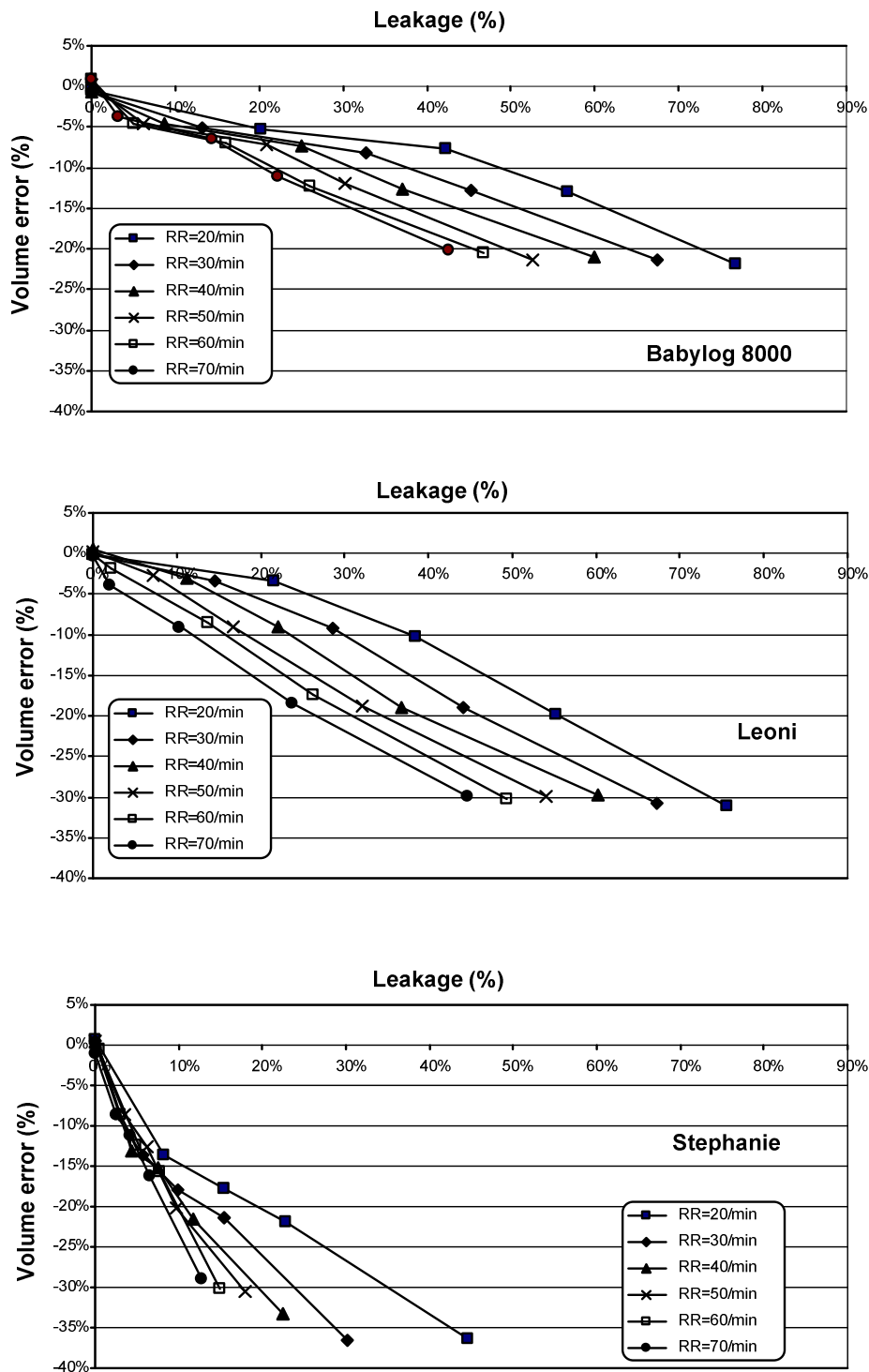

Figure 4.4. Relationship between volume error and displayed ET leakage for the three ventilators using respiratory rates between 20 breaths/min and 70 breaths/min.

4.1.2. Measurements of lung mechanics parameters

4.1.2.1. Measurement of lung mechanics in a leakage free system

The compliance of the lung model was 1.3 mL/cmH₂O. In the absence of ET leakage Babylog 8000 and Leoni showed a small but statistically significant ($p < 0.001$) systematic bias of the displayed compliance and in the RR range between 20 breaths/min and 70 breaths/min, this bias was nearly unchanged (Figure 4.5). The mean deviation in the compliance was for Babylog 8000, 0.15 ± 0.026 mL/cmH₂O, for Leoni, 0.04 ± 0.05 mL/cmH₂O and Stephanie showed no deviation.

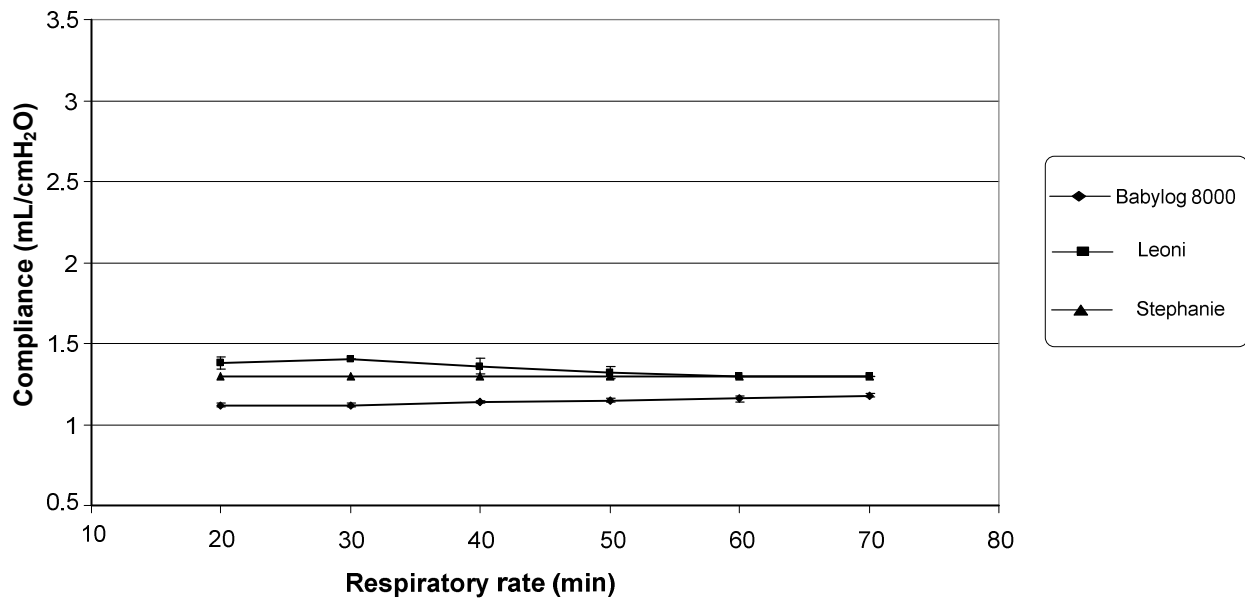

Figure 4.5. The compliance measurements of the three ventilators in relation to respiratory rate in the absence of ET leakage.

Compared to the compliance the assessment of the resistance measurements was more difficult because the resistance of the ET tube is highly flow-dependent and varied during the ventilator cycle as already described. Nevertheless, despite comparable measuring conditions there were distinct differences in the measured resistance between the investigated ventilators even in the absence of ET leakage ($p < 0.001$) as shown in Figure 4.6. In the absence of ET leakage for the three ventilators the effect of RR on the measured resistance was negligible. In the investigated RR range the mean resistances were for Babylog 8000, 69 ± 1 cmH₂O/L/s, for Leoni, 125.2 ± 0.7 cmH₂O/L/s and for Stephanie, 78.6 ± 1.9 cmH₂O/L/s.

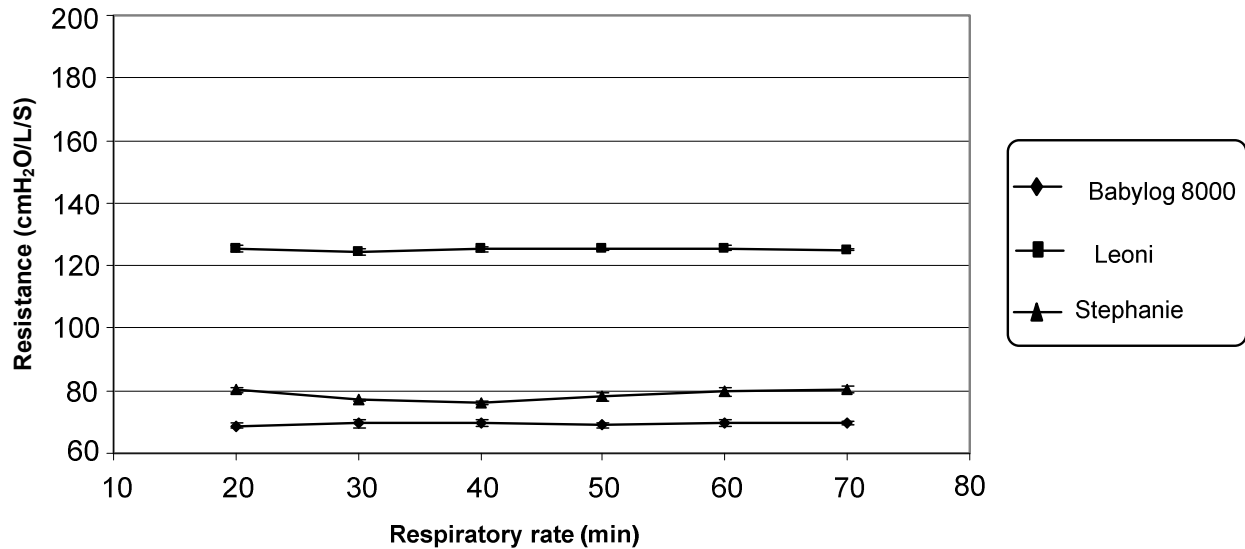

Figure 4.6. Resistance measurements of the three ventilators in the absence of ET leakages

4.1.2.2. Effect of ET leakage and respiratory rate on compliance measurements

The effect of ET leakage on the displayed compliance was quite different between the ventilators. The dependency of the measured compliance on ET leakage and RR is shown in Figure 4.7. For Babylog 8000 and Stephanie the displayed compliance was overestimated with increasing ET leakage and the higher the size of the leakage the higher the overestimation. For Leoni the measured compliance was underestimated with increasing size of ET leakage. In contrast to the other ventilators Leoni showed no dependency of the compliance measurement on the RR (Figure 4.7).

As shown in Figure 4.7, for a small ET leakage the dependency of the displayed compliance on RR was negligible, but, for the large ET leakage (leak 4) as shown in Figure 4.8 there was distinct RR dependence for Babylog 8000 and Stephanie. The measured compliance by Babylog 8000 overestimated from 1.38 ± 0.02 mL/cmH₂O (at RR 70 breaths/min) to 2.8 ± 0.07 mL/cmH₂O (at RR 20 breaths/min) and for Stephanie overestimated from 1.7 ± 0.0 mL/cmH₂O (at RR 70 breaths/min) to 6.18 ± 0.08 mL/cmH₂O (at RR 20 breaths/Min). but the displayed compliance by Leoni was constant (0.92 ± 0.04 mL/cmH₂O at 20 breaths/min and at 70 breaths/min). Figure 4.7 also shows that in all three ventilators for RR greater than 40 breaths/min the displayed compliance were nearly independent on the RR; however, the ET leakage-dependent error in the measured compliance remained.

The reproducibility of the serial measurements was very high. The median (range) of the coefficients of variation for Babylog 800 was 1.08% (0.41% – 2.71%), Leoni 0% (0% – 4.86%) and Stephanie 0% (0% – 3.1%).

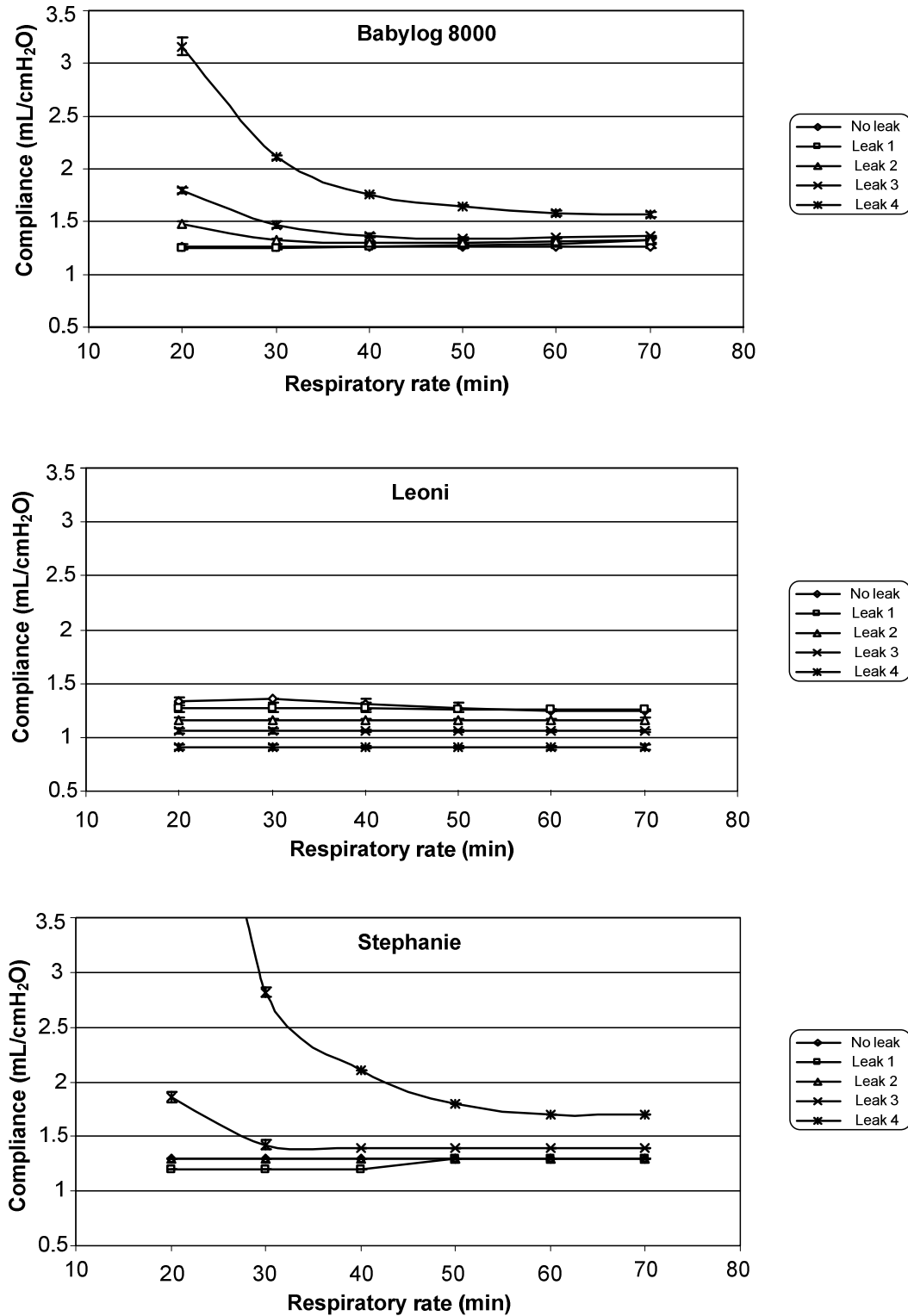

Figure 4.7. Compliance measurements of the three ventilators in relation to the respiratory rate and in the presence of different sizes of ET leakages.

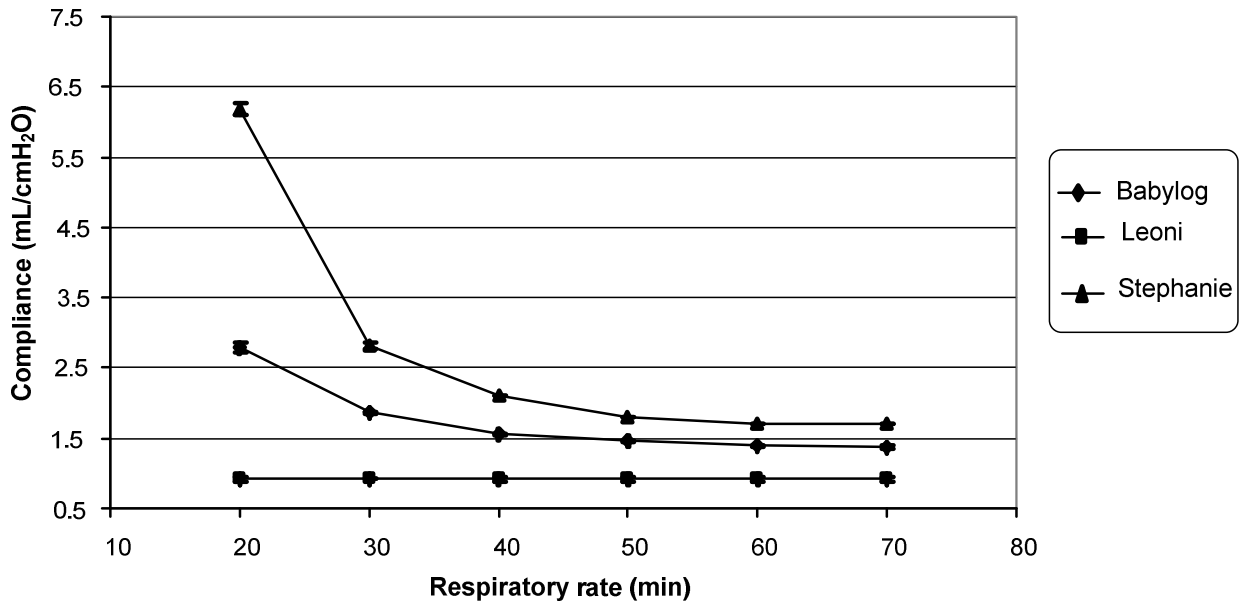

Figure 4.8. Compliance measurements of the three ventilators in relation to respiratory rate in the presence of the largest ET leakage (Leak 4).

4.1.2.3. Effect of ET leakage and respiratory rate on resistance measurements

In contrast with the compliance, the effect of ET leakage and timing parameters on the displayed respiratory resistance was distinctly higher but there are differences in the effect of the ET leakage on the displayed resistance between the ventilators (Figure 4.9). In all three ventilators, with increasing ET leakage the displayed resistance is overestimated.

As shown in Figure 4.9 for Babylog 8000 and Stephanie the resistance overestimated with decreasing RR and the overestimation was higher in the presence of large ET leakages. In contrast, for Leoni the effect of the RR on the displayed resistance was negligible.

A comparison of the three ventilators for the largest ET leakage (leak 4) and different respiratory rate is shown in Figure 4.10. The displayed resistance by the Babylog 8000 overestimated from 108 ± 1.2 cmH₂O/L/s (at 70 breaths/min) to 171 ± 4.2 cmH₂O/L/s (at 20 breaths/min), The displayed resistance by Stephanie overestimated from 111.6 ± 0.89 cmH₂O/L/s (at 70 breaths/min) to 186.2 ± 0.4 cmH₂O/L/s (at 20 breaths/Min) but the displayed resistance by Leoni was nearly constant (137.2 ± 0.68 cmH₂O/L/s at 20 breaths/min) and 136 ± 0.68 cmH₂O/L/s at 70 breaths/min).

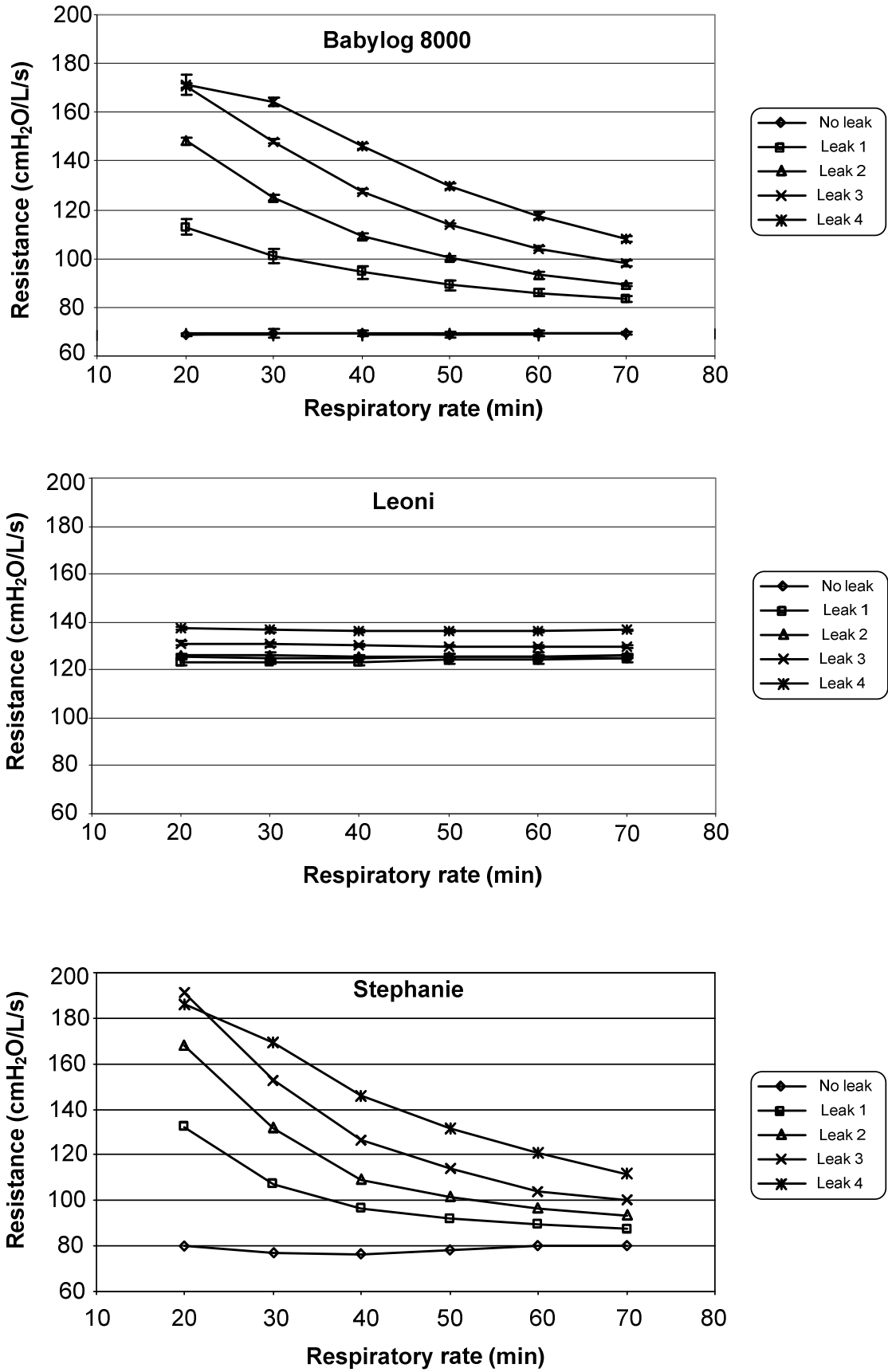

Figure 4.9. Resistance measurements by the three ventilators in relation to respiratory rate in the presence of different size of ET leakages.

As shown in Figure 4.10 the dependency of the displayed resistance on the RR for Babylog 8000 and Stephanie was nearly identical which may indicate that both ventilators use the same evaluation technique.

The reproducibility of the serial resistance measurements in the three ventilators was high. The median (range) of the coefficients of variation of all the resistance measurements of the three ventilators were 1.2% (0.58% – 2.97%) for Babylog 8000, 0.6% (0.12% – 1.63%) for Leoni and 0.9% (0% – 3.68%) for Stephanie.

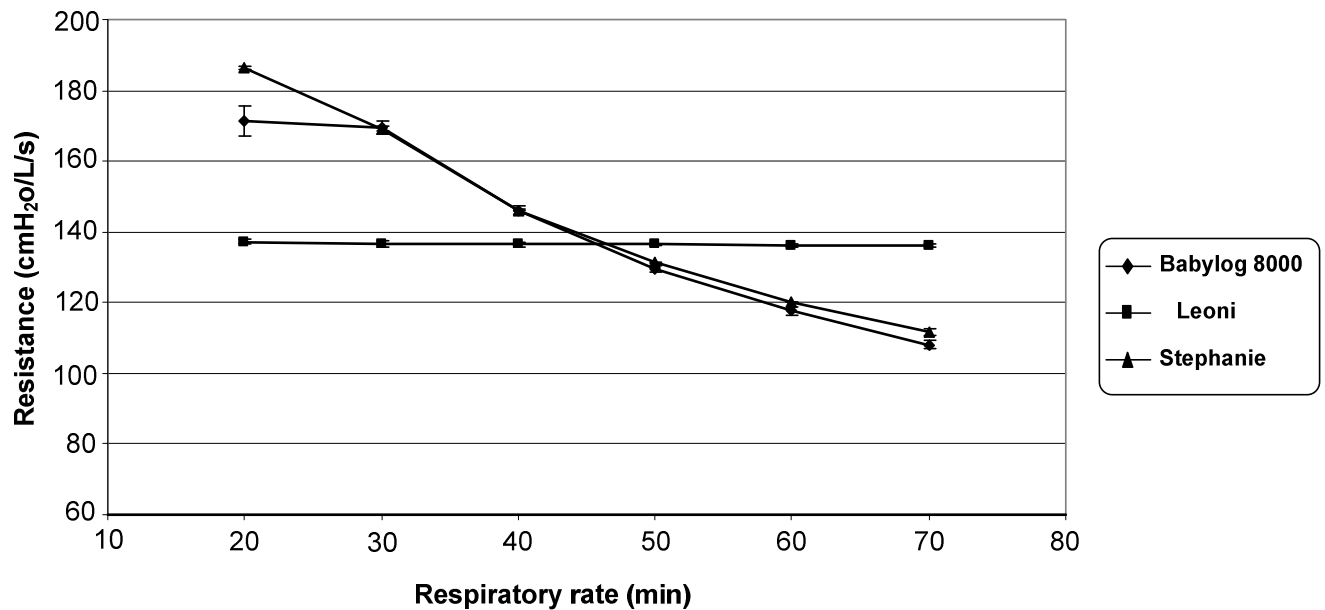

Figure 4.10. Resistance measurements of the three ventilators in the presence of a large ET leakage (Leak4).

4.2 Retrospective clinical study

4.2.1. Patients

During the evaluation period from August 2006 to December 2008 in total 163 infants fulfilled the inclusion criteria of this study and the main indications for mechanical ventilation (Table.4.1) were respiratory diseases of prematurity (N=63; 38.7% including RDS, apnea bradycardia syndrome, pneumothorax, and BPD), congenital heart disease (N=27; 17%), early or late infection (N=26; 16%), surgery for gastrointestinal malformations or NEC (N=21; 12.9%), congenital diaphragmatic hernia (N=10; 6%) and miscellaneous indications (N=16; 9.8% including asphyxia, meconium aspiration syndrome, congenital teratoma and hydronephrosis).

The median (range) gestation age of all 163 enrolled neonates was 31.1 (23.3 – 41.9) weeks and the median birth weight was 1470 g (410 – 4475 g). Of all the children, 122 (75%) were preterm and 116 (71.1%) were of low birth weight (<2500 g).

ET leakage of >5% was noted in 122 (75%) infants, whereas 41 (25%) infants had no such leakage (\leq 5%) during the entire period of mechanical ventilation. As shown in Table 4.2, there were significant differences between infants with and without ET leakage. Neonates with ET leakage had a significantly shorter gestational age ($p=0.004$) and a lower birth weight ($p=0.005$) and lower body weight at the time of mechanical ventilation ($p=0.01$). Furthermore, infants with ET leakage showed a greater incidence of re-intubation and mechanical ventilation ($p=0.003$) and the duration of mechanical ventilation was markedly longer ($p<0.001$) compared to infants without ET leakage. No differences between infants with or without ET leakage were seen in indications for mechanical ventilation (Table 4.1), except in the miscellaneous group ($p=0.029$) where infants without ET leakage were three times more common than those with ET leakage.

Table 4.1. Indications for mechanical ventilation between neonates with and without ET leakage (incidence and percentage in brackets, statistically significant p values indicated in bold).

Indications	Infants without ET leakage (\leq 5%) N=41	Infants with ET leakage (>5%) N=122	p value
Respiratory diseases of prematurity	14 (34.2%)	49 (40.2%)	0.580
Congenital heart disease	7 (17.1%)	20 (16.4%)	1.000
Infection	5 (12.2%)	21 (17.2%)	0.623
Operation for gastrointestinal tract malformations	5 (12.2%)	16 (13.2%)	1.000
Congenital diaphragmatic hernia	2 (4.9%)	8 (6.6%)	1.000
Miscellaneous	8 (19.5%)	8 (6.6%)	0.029

Table 4.2. Comparison of patient characteristics between neonates with and without ET leakage (medians with ranges or numbers with percentages) are shown, with statistically significant p values of <0.05 indicated in bold).

	Infants without ET leakage (≤5%) N=41	Infants with ET leakage (>5%) N=122	P value
Gestational age (weeks)	32.7 (25.9 – 40.0)	29.4 (23.3 – 41.9)	0.004
Birth weight (g)	1780 (590 – 4475)	1200 (410 – 4095)	0.005
Body weight at time of mechanical ventilation (g)	1880 (590 – 5430)	1452 (420 – 5700)	0.01
Age at time of mechanical ventilation (days)	1 (1 – 35)	2.5 (1 – 79)	0.003
Re-intubation and mechanical ventilation	4 (9.8%)	49 (40.2%)	0.015
Duration of mechanical ventilation (days)	2 (0.2 – 7)	6 (0.2 – 46)	<0.001

4.2.2. Extent of the ET leakages

The median ET leakage of all patients with ET leakage greater than 5% at the three investigated time-points and the within-subject variability given by the highest and lowest leakage during 24 h are shown in Figure 4.11. Clearly, a wide variation in ET leakage was observed during the 24 h observation interval. As shown in Table 4.3, in more than 50% of all infants, the first ET leakage of >5% occurred within the first 24 h of mechanical ventilation. The highest ET leakage was seen on the third day of mechanical ventilation and not on the day of extubation.

As shown in Figure 4.11 on the day the highest ET leakage was noticed, 97 (59.5%) of all enrolled neonates (N=163) had an ET leakage >20%. However, 69 (42.3%) neonates had at least one ET leakage >40% over the entire duration of mechanical ventilation. On contrast, on the day of extubation, 83 (51%) infant had an ET leakage >5% but only 48 (29.4%) neonates had an ET leakage (>20%).

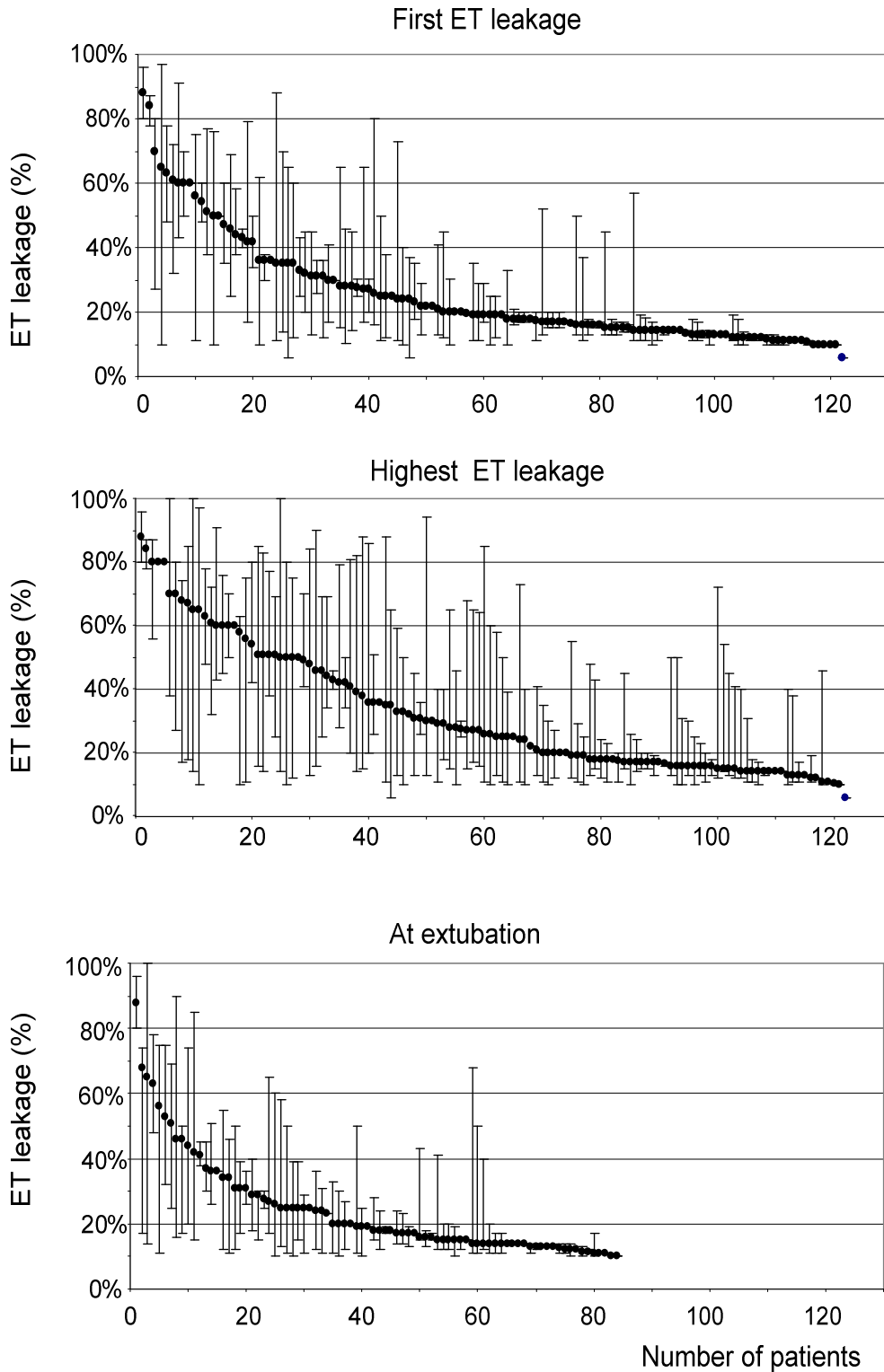

Figure 4.11. Highest, lowest, and median (dotted) ET leakages of patients on the day on which ET leakage (>5%) was first noted (top), on the day on which ET leakage peaked (middle), and on the day of extubation (bottom), in the order of median ET leakage.

Table 4.3. Age of patients, ET leakage and the corresponding displayed tidal volume on the day on which ET leakage (>5%) was first noted, on the day on which ET leakage peaked, and on the day of extubation. (N=122) (medians and ranges are shown).

	Day on which ET leakage (>5%) was first noted	Day of highest ET leakage	Day of extubation
Age (days)	2.5 (1 - 79)	6 (1 - 85)	10 (1 - 86)
Duration of mechanical ventilation (days)	1 (0.2 - 13)	3 (0.2 - 33)	6 (0.2 - 46)
Lowest ET leakage (%)	13 (6 - 80)	13.5 (6 - 80)	11 (0 - 80)
V _T (mL/kg)	4.32 (0.94 – 7.9)	4.55 (0.95 – 7.9)	5.10 (0.95 – 7.91)
Median ET leakage (%)	19 (6 - 88)	25.5 (6 – 88)	14 (0 - 88)
V _T (mL/kg)	4.13 (0.63 - 7.9)	4.32 (0.63 – 7.9)	4.92 (0.63 – 7.87)
Highest ET leakage (%)	25 (6 - 97)	46 (6 - 100)	17 (0 - 100)
V _T (mL/kg)	4.12 (0.3 – 7.63)	3.92 (0.32 – 7.63)	4.65 (0.32 – 7.87)

4.2.3. Influencing factors on ET leakages

The ET diameter ranged between 2mm and 4mm, as shown in Figure 4.12. When ETs less than 3mm in diameter were used, there was a statistically significance relationship between ET diameters and ET leakages. This relationship increased with extended duration of mechanical ventilation and was highest on the day of extubation. But for ETs greater than 3mm diameter there was no significant relationship between ET diameter and ET leakage.

Throughout the duration of mechanical ventilation, the ventilator settings were changed as shown in Table 4.4. There was a significant reduction in RR, T_{insp}/T_{exp} ratio and PIP (all $p<0.001$). However, there was no statistically significant correlation between the ventilator settings and the ET leakage. Nevertheless, Spearman rank correlation analysis showed that the highest recorded ET leakage increased with increasing duration of mechanical ventilation ($R_{sp}= 0.325$, $p<0.001$). Significant correlations were also found between the extent of ET leakage and both body weight at the time of mechanical ventilation ($R_{sp}= - 0.271$, $p=0.003$) and gestational age of ventilated neonates ($R_{sp}= - 0.265$, $p=0.004$). The negative correlation coefficients indicate that ET leakage increased with decreasing body weight and gestational age.

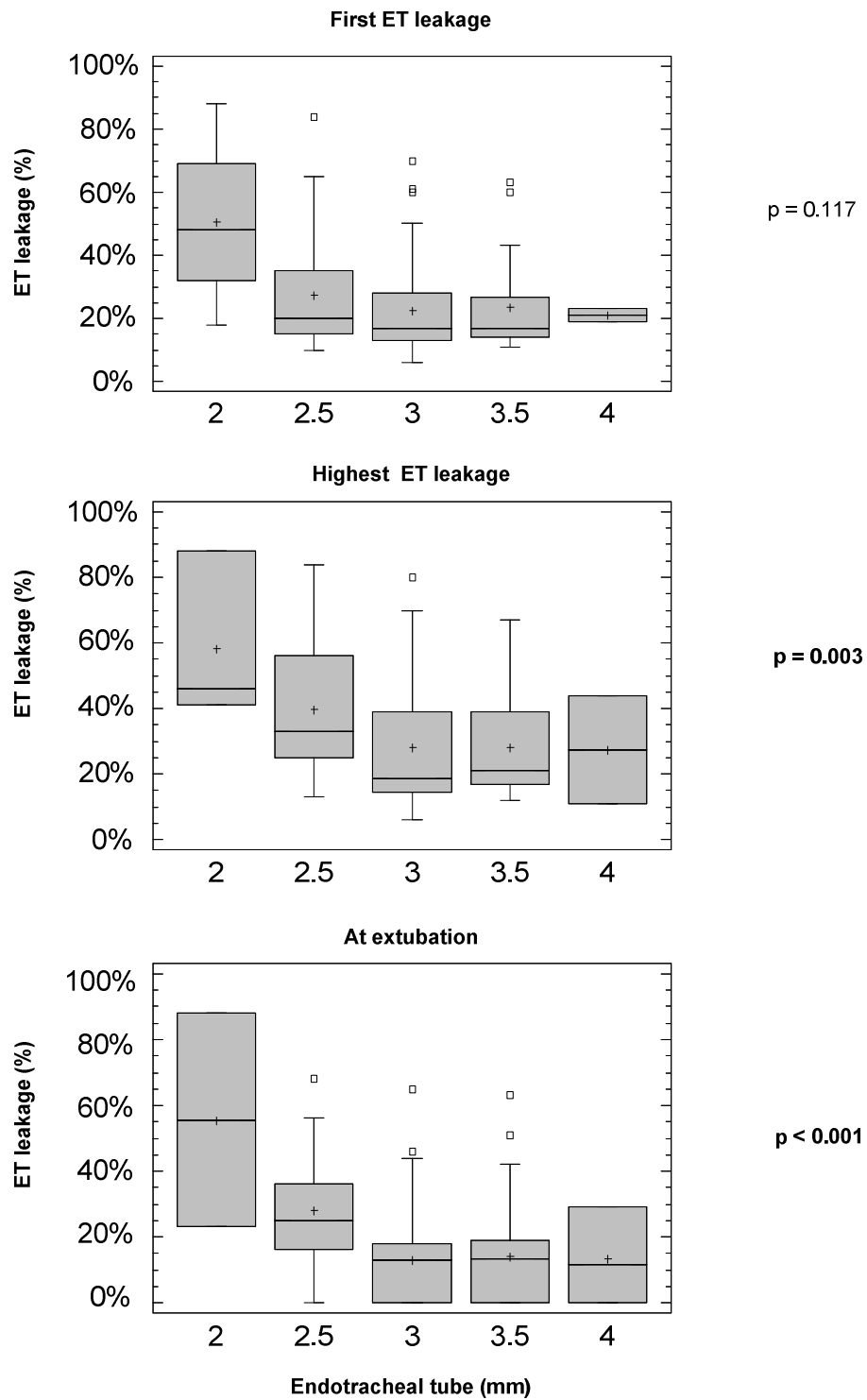

Figure 4.12. Relationship between displayed ET leakage (as a percentage) and the diameter of the ET tube employed on the day on which ET leakage (>5%) was first noted (top), on the day ET leakage peaked (middle) and on the day of extubation (bottom).

Table 4.4. Ventilator settings for neonates with ET leakage (N=122) (Presented as mean (SD) and compared by ANOVA for repeated measurements, with statistically significant p-values indicated in bold)

	Day on which ET leakage (>5%) was first noted	Day of highest ET leakage	Day at extubation	p- value
RR (breaths/min)	42 ± 11.6	39.8 ± 12.3	35.3 ± 10.2	<0.001
T _{insp} / T _{exp} (sec)	0.29 ± 0.09	0.27 ± 0.10	0.23 ± 0.08	<0.001
PIP (cm H ₂ O)	20.7 ± 5.79	20.5 ± 5.67	19.4 ± 4.90	<0.001
PEEP (cm H ₂ O)	5.05 ± 0.68	5.18 ± 0.67	5.15 ± 0.62	0.067
Flow (cm H ₂ O)	7.67 ± 2.90	7.64 ± 2.83	7.60 ± 2.60	0.978

4.2.4 Relationship between ET leakages and volume underestimations

The within-subject variability of ET leakage during 24 h period is associated with a variability in the displayed V_T . The relationships between increasing ET leakage difference (highest ET leakage – lowest ET leakage) and underestimation of displayed V_T are shown in Figure 4.13.

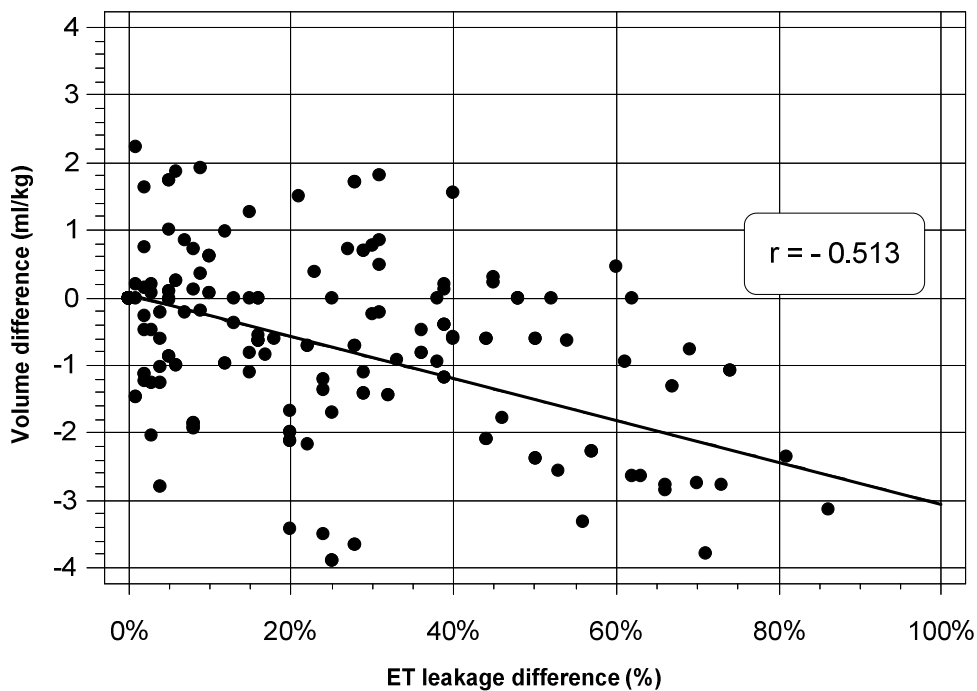

Figure 4.13. Regression analysis of the relationship of the difference between the highest and the lowest the ET leakage and the corresponding V_T difference during a 24h period in all neonates for whom ventilator settings were not changed, at the three nominated time-points.

In Figure 4.13, the data from only neonates for whom ventilator settings were not changed were pooled. This means that if the ventilator setting were changed during the 24 h observation period the ET leakage difference was not evaluated. This was to avoid the effect of changed ventilator settings on displayed V_T .

Despite of the high inter-subject variability shown in Figure 4.13, there was a statistically significant correlation ($r = -0,513$, $p < 0.001$) between increasing ET leakage and underestimation of displayed V_T . The regression line shows that an ET leakage of 40% indicates that the displayed V_T was underestimated by 1.2 mL/kg, thus by about 24% of target V_T (generally 5mL/kg).

5. Discussion

5.1. In-vitro measurements

5.1.1. Air leakage flow and its influence on volume measurements

Almost all neonatal ventilators measure the air flow to and from the patient by a flow sensor sited between the Y-piece and the ET (156). If a leakage around the ET tube is present, the measured flow signal is a superimposition of patient flow and leakage flow, as shown in Figure 5.1. The leakage flow depends on ventilator pressure and leak resistance and leads to a shift in the flow baseline. This affects V_T measurement by the ventilator ($V_{T \text{ vent}}$) which is calculated as the area under the flow curve.

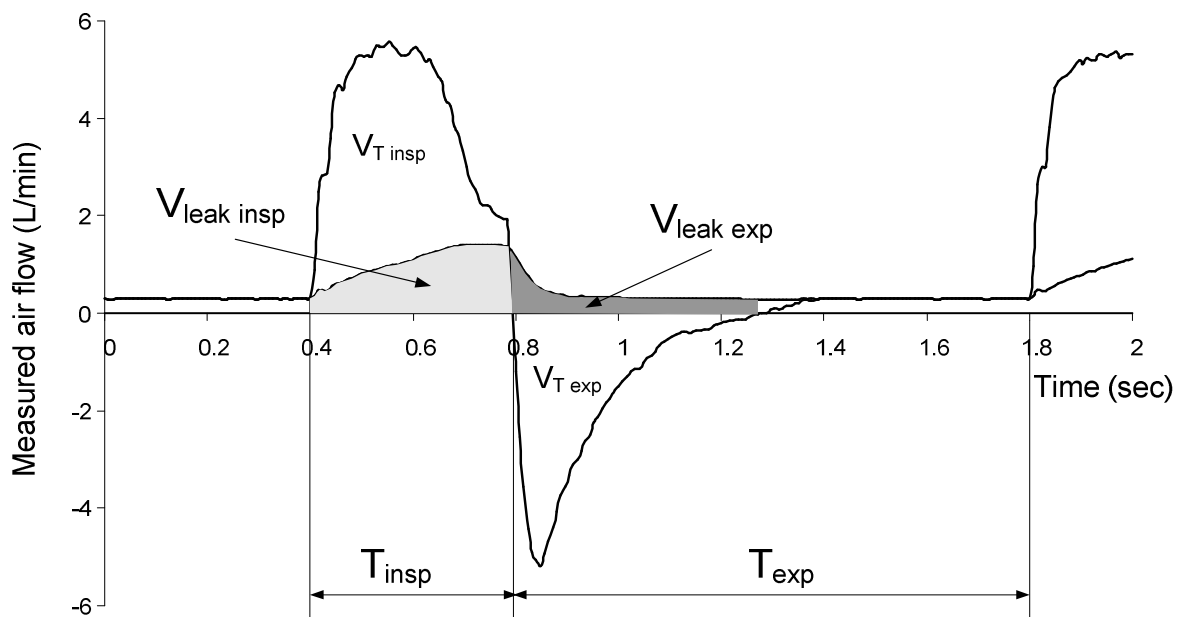

Figure 5.1. Superimposition of the measured inspired and expired airflow and the leakage flow (shadowed areas). Volumes are given by the areas under the flow curves.

As shown in Figure 5.1. the measured inspiratory and expiratory volumes are given by:

$$V_{T \text{ insp}} = V_T + V_{\text{Leak insp}} \quad \text{and} \quad V_{T \text{ exp}} = V_T - V_{\text{Leak exp}} \quad (4)$$

Where $V_{\text{Leak insp}}$ and $V_{\text{Leak exp}}$ were the volumes which escaped through the leak during inspiration and expiration, respectively. Thus the inspired volume was overestimated and the expired volume underestimated by the leakage volume. In this formula, the small volume error caused by the reduction in exhalation time due to the shift of the zero line was neglected.

Thus in the presence of ET leakage the measured inspired and expired volume is given by

$$V_{T \text{ insp}} = V_T + V_{\text{leak insp}} = V_T + \frac{1}{R_{\text{Leak}}} \int_0^{T_{\text{insp}}} P(t) \cdot dt \quad (5)$$

$$V_{T \text{ exp}} = V_T - V_{\text{Leak exp}} = V_T - \frac{1}{R_{\text{Leak}}} \int_{T_{\text{insp}}}^{T_{\text{exp}}} P(t) \cdot dt \quad (6)$$

Where $P(t)$ is the ventilator pressure. The formulas demonstrate how the volume error depends on the adjusted ventilatory pressures and the timing parameters of the breathing cycles. Only if all the variables in formulas 5 and 6 can be measured can a volume correction be possible.

Using the definitions of Equation 4 and the formula of ET leakage definition as previously given by Equation 1:

$$\text{Leakage (\%)} = 100 \cdot \frac{V_{T \text{ insp}} - V_{T \text{ exp}}}{V_{T \text{ insp}}}$$

We can obtain the following leakage formula:

$$\text{Leakage (\%)} = 100 \cdot \frac{V_{\text{Leak insp}} + V_{\text{Leak exp}}}{V_T + V_{\text{Leak insp}}} \quad (7)$$

It is obvious that there is no simple relationship between the calculated leakage (in percentage terms) and the leakage volume during inspiration and expiration ($V_{\text{leak insp}}$ and $V_{\text{leak exp}}$), which depends on ventilatory pressures, leakage resistance, timing of the breathing cycles and lung respiratory mechanics (135;161). Furthermore in most ventilators it is not known in detail how volumes and leakages are calculated, or if volume correction algorithms are installed.

The in-vitro study has shown that there are distinct differences in the measured ET leakage and in the relationship between ET leakage and volume error between the three investigated ventilators. The lower leakage-dependent volume error measured with Babylog 8000 (shown in Figure 4.1) and the distinctly lower displayed ET leakage by Stephanie (shown in Figure 4.2) indicate different algorithms are needed to measure volume and ET leakage (86;166). This hampers the comparability between different ventilators and some recommendations in the literature concerning the acceptance of ET leakages cannot be generalized. For example, Main et al. (123) found that ET

leakages of less than 20% are acceptable to obtain reliable measurements of V_T . This may be true for the Babylog 8000 but not for Stephanie.

5.1.2. Tidal volume and ET leakage measurements

The in-vitro measurements described in Chapter 3.1 have shown that in the presence of ET leakages the displayed expiratory volume by the ventilators underestimated the volume delivered in the lung in different ways. As shown in Figure 4.1, with increasing ET leakage the displayed volume decreased despite the fact that the delivered volume in the lung was nearly constant. Only in the Stephanie ventilator was there a small decrease in $V_{T \text{ Lung}}$ of about 5.6% with increasing ET leakage, likely due to the higher exhalation resistance (higher resistance of the pneumotach compared to the anemometric flow sensors, and higher resistance of the expiratory limb due to the usage of internal tube heating).

Furthermore, the measured ET leakage depended on the timing parameters of the breathing cycle so that comparisons of ET leakages and displayed volumes are only possible if the same respiratory rate is used. The study has clearly shown (Figure 4.2) that with increasing inspiratory time in all three ventilators the displayed ET leakage increased which impaired the comparability of the ET leakage monitoring.

Volume and ET leakage monitoring in ventilated neonates to prevent lung over-inflation is currently a clinical standard and realized in neonatal ventilators. Air flow is commonly measured by a flow sensor sited between the Y-Piece and the ET, which allows the most accurate measurements (29). However, the insertion of the flow sensor increased the apparatus dead space, which could lead to unacceptable CO_2 rebreathing, mainly in preterm infants (58), and impaired the alveolar gas exchange (162). Dead space free flow measurements, for example by measurements in the expiratory limb (88) or simultaneously in the inspiratory and expiratory limb (63), are possible, but their technical expense is distinctly higher and the accuracy lower.

Volume measurements during mechanical ventilation require a sophisticated technology and measuring errors between the ventilators of less than 10% in leak-free systems are accepted (156). In the present study, the measuring error of V_T between the ventilators in a leak-free system was eliminated by numerical correction of the

measured volumes, as the aim of this study was to investigate the relationship between the $V_{T\text{ vent}}$ and $V_{T\text{ lung}}$ and their dependence on ET leakages and timing parameters.

Irrespective of the measuring technique used, ET leakages will lead to errors in the measured volume, but ET leakages may have also a positive effect. The leak flow washes out the exhaled CO_2 from the dead space of the flow sensor of the ET and reduces CO_2 re-breathing. For volume monitoring in preterm infants Clure et al. (34) suggested the insertion of an artificial leak between the flow sensor and the ET to reduce the dead space of the apparatus virtually. However, it is not known how to adjust such a leak because the effect of the leak flow on the CO_2 washout depends on the ventilator pressures and the flow curve of the exhalation. Moreover in recent study by Nassabeh et al. (132) showed that dead space of the flow sensor was not affect ventilation because the fresh gas penetrates through the dead space, rather than pushing it ahead.

In neonatal ventilators, the ET leakage is presented as percentages and calculated by the difference between inspired and expired volumes. Despite the dependence of the displayed ET leakage by the RR, this form of leakage measurement is also affected by several technical e.g. differences in the transfer characteristics of the pneumotach on inspiration and expiration, or quality of breath detection (165) and physiological e.g. instability of end-expiratory lung volume (163) or changes in respiratory compliance parameters (123).

The measurement of air leakages in percentages may be appropriate in virtually airtight systems and is commonly used to monitor air tightness during mechanical ventilation. However, during mask ventilation or nCPAP, much higher leak flows (e.g. oral leakages) can occur (see Chapter 2.3.1) which cannot be measured using this technique because the leakages exceed the measuring range of ventilators (e.g. 90% in Leoni ventilator) (61;161) .

Besides the volume monitoring, air flow measurements are the basis for volume target ventilation (VTV) (see Chapter 2.2.3) where the ventilator pressures were adapted to the measured V_T as VG mode. As shown by Schulze (166) numerical leakage corrections of the flow signal are necessary to prevent an inappropriate increase in the ventilator pressure. However, it is not known to what extent such leakage corrections affect the volume monitoring.

5.1.3. Effect of ET leakages on volume errors

The relationship between ET leakage and volume error shown in Figure 4.4 was complex and differed between the three ventilators. The volume error depended on ET leakage and respiratory rate. This means that any change in the RR may change both the displayed ET leakage and the resulting volume error. Furthermore, a threshold for a clinically acceptable ET leakages which results in volume errors (e.g. <10%) is difficult to define because it depends on the RR and the ventilator used. As already emphasized, general recommendations about an ET leakage are not possible and numerical corrections of the volume error difficult.

In several past studies the effect of ET leakage on the measurements of ventilation (86;95;123) was investigated and algorithms to correct the leakage-dependent measuring error were suggested. Herber-Jonat et al. (86) described an algorithm for volume correction using the air flow and pressure signals separately from the inspiratory and expiratory period. Because the leak flow also depends on lung mechanics such algorithms can only approximately correct the volume error. Nevertheless, Herber-Jonat et al. (86) found that in a lung model the volume correction was possible for ET leakages up to 90%. However such corrections need external signal processing which is not commonly available. The aim of this study was to investigate the informative potential of the displayed V_T and ET leakage by the ventilator, mainly for the assessment of volume under-reading. However, the exhalation time of the neonate (which is commonly lower than the adjusted T_{exp} as shown in Figure 5.1) is not known so these correction algorithms cannot be applied.

Leak flow also affects the volume delivered in the lung by virtue of the pressure drop $\Delta P(t)$ across the ET, which is given by:

$$\Delta P(t) = \frac{R_{F\text{sensor}} + R_{ET}}{R_{F\text{sensor}} + R_{ET} + R_{Leak}} P(t). \quad (8)$$

Where $R_{F\text{sensor}}$ is the resistance of the flow sensor of the ventilator. This pressure drop reduces the inspired volume and decreases the PEEP. If R_{leak} is sufficiently high, the pressure drop caused by the leak flow is negligible. In this study, we did not find a relevant effect of the simulated leak on $V_{T\text{Lung}}$, because R_{Leak} was always distinctly higher than the other flow resistances (Table 3.2). The R_{leak} also reduced the exhalation resistance and so also the time constant which is the product of compliance and

resistance. However, if R_{leak} is much higher than the other exhalation resistances then this effect on lung mechanics is also negligible. Thus the change in the baseline of the measured flow signal as shown in Figure 5.1 remains the most important influencing factor of ET leakage for volume measurements.

5.1.4 Lung mechanics measurements

The in-vitro study has shown that the ET leakage had a much stronger effect on the measurement of lung mechanics compared to ventilatory measurements. Besides the accuracy of the flow and pressure measurements (115), the measured respiratory compliance and resistance also depends on the phase shift between pressure and flow waveforms (26) and the correct identification of the beginning and end of the breathing cycle (165). An ET leakage does not only affect the magnitude of the flow and volume signal but it also the phase shift between the measuring signals which makes the assessment of ET leakage on the measured lung mechanics parameters much more difficult (134).

Furthermore in contrast to the measurement of V_T , there are several methods to calculate lung mechanics parameters which can lead to different results (e.g. calculation during inspiration or expiration or during the whole breathing cycle) (40). In neonatal ventilators, the most common technique is the use of the linear resistance-compliance model and the determination of the model parameters by the method of least squares analysis (121). However, in most instruction manuals of the ventilators the methods that are used to calculate compliance and resistance are not described in detail. For example, Babylog 8000 used a linear regression analysis but no details of calculation were found for Leoni and Stephanie.

The in-vitro study has shown that the effect of ET leakage on the displayed lung mechanics parameters was different in the three ventilators. Thus in the presence of ET leakage the comparability of lung mechanics measurements between different ventilators is hampered. This may be considered in further clinical studies in ventilated newborns using different ventilators.

To reduce the effect of ET leakage on the measurement of lung mechanics different algorithms for leakage corrections were suggested (86;135;166). Nikischin et al. (135) developed a mathematical algorithm for correction of compliance up to a leakage of 80% and resistance up to a leakage of 55%, even if there were non-linear

pressure volume relationships. Similar to the volume correction these numerical corrections are also based on the knowledge of the measured flow and pressure signal at the Y-piece during the ventilator cycle, which are parameters not commonly available to clinicians.

The present study has also shown that the relationship between ET leakages and measuring errors of lung mechanics was highly dependent on the ventilator used, and some recommendations in the literature about the acceptance of lung mechanics measurements in the presence of ET leakages cannot be generalized. Kondo et al. (112) suggested that these measurements would be reliable only if the expiratory portion of the breath was used, while Main et al. (123) found that measurement of lung mechanics was unreliable in both the inspiratory and expiratory portion of the breath if ET leakage was greater than 20%.

The leakage dependent measuring error of lung mechanics could lead to false clinical interpretations. Babylog 8000 and Stephanie overestimated the displayed compliance with increasing ET leakage, which could mimic an improvement in lung mechanics and an actual deterioration was not seen. On the contrary, the Leoni ventilator underestimated the displayed compliance which mimicked a deterioration of lung mechanics and an actual improvement was not seen.

The interpretation of the measured resistance was difficult due to their flow-dependency (Figure 3.3). There were big differences in the measured resistance between the ventilators, however, in the three ventilators the measured resistance increased with increasing ET leakage. Thus, the presence of ET leakage could lead to a false impression that the respiratory airway or the ET tube was obstructed.

In clinical practice the value of resistance monitoring is limited because it is impacted by multiple factors, including airway diameter, respiratory muscle activity, gas flow, PEEP, ET tube (45) and the type of ventilator used (122) So it is only to be used to monitor the conductivity of the respiratory airway and the ET tube.

The displayed ET leakage is also affected by lung condition. In the presence of lung disease with reduced compliance, the increase in ventilator pressures will also increase the leak flow. The errors in measurements of resistance and compliance have been found to be relatively larger in stiff lungs compared to healthy lungs for all magnitudes of ET leakage (123).

5.1.5. Limitations of the in-vitro study

The in-vitro model used in this study was well situated to investigate the influence of ET leakages on ventilatory measurements and this model was already used in similar ways in several leakage studies (62;86;135). For the measurements of lung mechanics, there are some limitations. The compliance slightly pressure dependent due to the non-linear pressure volume characteristic. More difficult was the interpretation of the resistance due to its flow dependency so that a measuring error of the lung mechanics parameters could not be calculated (Figure 3.3). However, the three ventilators were tested by the same model and with identical parameter settings so that the comparability in the measured lung mechanics parameters between the ventilators was given.

Compared to a human lung there are some limitations in the model. Not considered in this model were pulmonary non-linearity and in-homogeneity. However, for the volume measurement this is not a disadvantage provided that the exhalation time is shorter than the adjusted T_{exp} of the ventilator. In this study, this was given for all parameter settings because the time constant of the lung model was about 70 ms, which is not untypical for preterm newborns. Therefore the expiratory volume was independent of the adjusted T_{exp} . However, in the case, that the exhalation time is longer than the adjusted T_{exp} of the ventilator the expiratory volume will depend on the adjusted T_{exp} and the relationship between air leakage and volume error will be much more complex.

An important limitation was that the superimposition of a measured flow signal by spontaneous breathing was not considered, which could have seriously impaired calculation of both V_T and ET leakage. However, in this study ideal conditions were simulated so that the relationship between ET leakage and the displayed V_T could be investigated in detail. Moreover, ventilator manufacturers did not describe in detail, which methods were used to calculate lung mechanics parameters, thus calculation of inspiratory and expiratory parameters, or averaging over the whole breathing cycle could lead to different results.

Despite all these limitations, the in-vitro study using the devolved mechanical lung model could demonstrate the relationship between the displayed V_T and lung mechanics parameters on the one hand and displayed ET leakage on the other, and their dependency on the ventilator used.

5.2. Retrospective clinical study

5.2.1. Patients and data recording

The 163 patients evaluated in this study reflected the current population of ventilated infants treated in our NICU. In the study period from August 2006 to December 2008 the data of all ventilated patients were evaluated. As shown in Figure 5.2, there was a distinct decrease in the incidence of mechanical ventilation during the last ten years. In comparison, about 71% of neonates admitted to NICU in 1998 were mechanically ventilated but only 40% in 2008. Not considered in these statistics were infants who received non-invasive ventilatory support such as CPAP or HFNC (see Chapter 2.2.1). One explanation for the reduction in the incidence of mechanical ventilation may be the new strategy of increased use of CPAP and avoidance of intubations in premature infants with RDS (104;130).

In the present study, the most common indications for mechanical ventilation were RDS, as defined in Chapter 2.1.2, which accounted for about 30% of all ventilated neonates. RDS is the most common cause of respiratory disease which occurs in more than half of preterm infants born at less than 30 weeks of gestational age (148), and it is the most common indication for mechanical ventilation during the neonatal period.

During the study period, the median gestation age was 31.1 weeks and the median birth weight was 1470 g. Thus, the half of all ventilated infants were of VLBW (<1500 g). As shown in Figure 5.3 there was a moderate increase in the percentage of VLBW and extremely low-birth-weight infants (ELBW) infants admitted to our NICU during the last four years. This may be explained by the major advance in both obstetric and neonatal care during the last decade which was associated with decreases in mortality and morbidity in such infants (56;91).

The retrospective clinical study was based on the evaluation of patients' medical records which were routinely recorded every 3 h. However, there was no information about the manipulation of the patient to reduce the ET leakage. A retrospective analysis has further problems that the recommended sizes of ET were determined by the commonly used weight-based method according to the Neonatal Resuscitation Program (102) as described in Chapter 3.2.1, But the decision to use a smaller ET if a failure of intubation with the appropriate ET was not recorded because only the ET size with which the baby was intubated with was recorded.

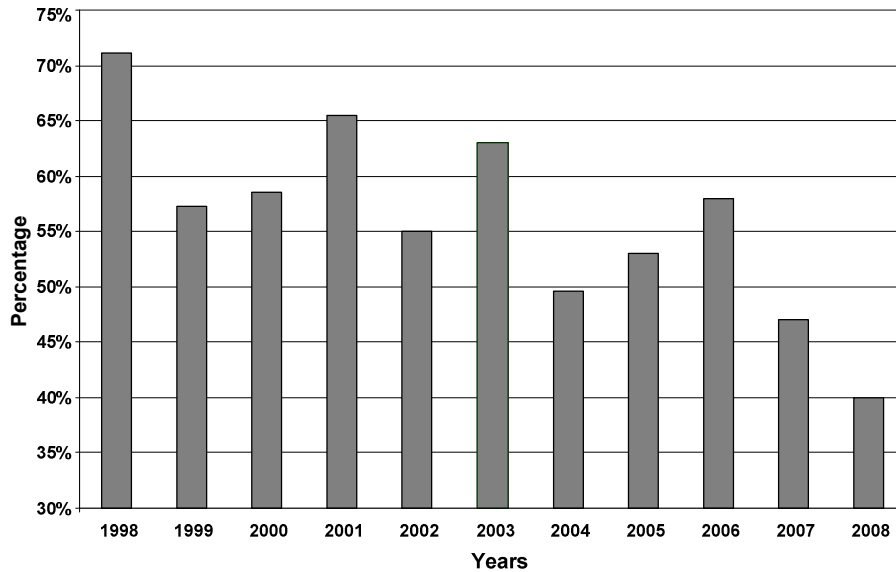

Figure 5.2. Incidence of mechanical ventilation in NICU of Department of Neonatology, Charité Universitätsmedizin Berlin, Campus Mitte (without other forms of non-invasive ventilatory support).

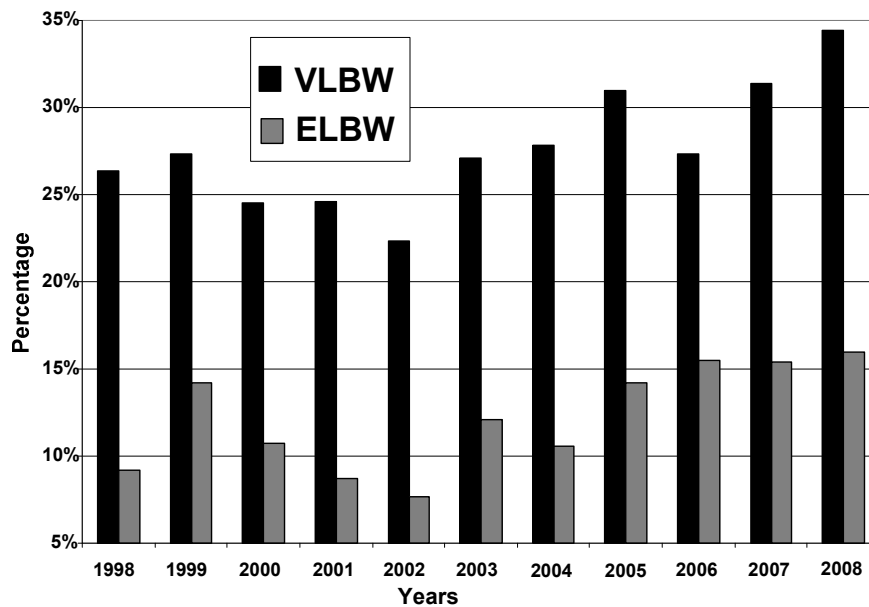

Figure 5.3. The incidence of very low birth weight infants (VLBW) and extremely-low-birth weight-infants (ELBW) in NICU of Department of Neonatology, Charité Universitätsmedizin Berlin, Campus Mitte.

In the evaluation of the records, infants with and without ET leakages were distinguished. Without ET leakage meant an ET leakage less than 5% as smaller leakages were not reliably displayed by the Babylog 8000. From the infants without ET leakage only reduced amounts of data were evaluated, as described in Chapter 3.2, as this study aimed to investigate the extent of the ET leakage and its influence on the displayed V_T .

No relationship between clinical indications for mechanical ventilation and ET leakage was seen except in the miscellaneous group (e.g. asphyxia, meconium aspiration syndrome) (Table 4.2). This was because infants in this indication group were mostly full-term infants ventilated for a short period of time with an ET greater or equal to 3 mm diameter, and as was shown in this study the incidence of ET leakage in these infants is significantly lower compared to preterm infants.

5.2.2. Extent of ET leakages and factors affecting ET leakages

The main finding of this study was that ET leakage greater than 5% occurred in about 75% of all ventilated neonates. A high ET leakage greater than 40%, with clinically relevant errors in displayed V_T , were periodically seen in 42.3% of all infants receiving mechanical ventilation, commonly on the third day of ventilation. At the day of extubation the ET leakage was decreased and only 83 (51%) infant had ET leakage >5%. This may be explained by the replacement of the ET tube by a larger one in 27 (17%) of 163 ventilated infants. Bernstein et al. (16) analyzed 50 ventilated infants with a mean body weight of 1400 g using an InfantStar ventilator. They found that an ET leakage greater than 10% occurred in 70% of children, which is in agreement with our data. Higher ET leakages (>30%) occurred in only 8% of ventilated infants. However, it is not known to what extent the leakage measured with the InfantStar ventilator can be compared with the measurements by the Babylog 8000.

In the present study, ET leakage was retrospectively evaluated and the data therefore represent leakage measured in a clinical routine. All infants were treated with the same ventilator to allow comparison of measured ET leakage (161). As shown in the in-vitro study the displayed leakage was highly device-dependent and leakage measurements between different devices can hardly be compared.

The size of the ET leakage is determined by the placement of the ET in the trachea. This study has shown that preterm infants with low birth weight and gestational age ventilated with ETs lower than 3 mm in inner diameter for long duration were at the greater the risk of ET leakage. This means that VLBW infants, for who V_T is small and adjustment is critical, are at greatest risk for ET leakage and resulting errors in measured V_T . The exposure of preterm infant upper airway for long duration to cyclic stretch imposed by ventilator pressure has been associated with progressive dilation of

the trachea and larynx (19;169). This may be explaining the increase ET leakage in such infants. Furthermore, even when high ET leakage present, the cautious choice of ET tube size in preterm infants to prevent any airway damage, and clinical decisions to avoid re-intubation even though ET leakage may be increasing further explain why these tiniest infant as the greatest risk for ET leakage.

During the entire duration of mechanical ventilation, the ventilator settings were reduced. Theoretically, a reduction in PIP should lead to a reduction in the leak flow and to a lower ET leakage. However, as shown in Table 4.4 the PIP reduction was 1.3cm H₂O and this difference is likely to low to produce measurable changes in the ET leakage. Other previous influencing factors on an airtight placement of the ET may have a higher impact on the ET leakage than the ventilator settings.

This retrospective study showed that high ET leakages (>40%) with clinically relevant volume errors can occur during mechanical ventilation which require a suitable ET leakage management (e.g. change of infant head position, change of ET tube position, gentle traction on trachea). If this is not successful and the gas exchange is impaired a re-intubation with a bigger ET tube is indicated.

Furthermore, ET leakage can be prevented by using cuffed ET tubes, which enables better V_T monitoring during mechanical ventilation and avoids the need for multiple intubation attempts for determination of a proper sized ET (59). Ventilation with cuffed ET provides an optimal and constant level of ventilation and PEEP, which may be hampered in the presence of ET leakage due to uncuffed ET. In a prospective study, Newth et al. (133) successfully used modern low-pressure and high-volume cuffed ET for ventilated children and neonates in intensive care units with ET greater than or equal to 3 mm internal diameter. They showed that the use of cuffed ET in critically ill children is not associated with a higher incidence of post-extubation stridor and subsequent racemic epinephrine inhalations, provided ET sizes are carefully selected and the cuff pressures are meticulously monitored. In another recent study (186) to report normal reference data for forced and passive expiratory lung function in intubated, anesthetized and paralyzed infants and children up to 5 years of age, cuffed ET up to 3 mm in diameter were used. However in NICUs, uncuffed ETs have been the gold standard to prevent airway damage (36). Furthermore, cuffed ETs have a greater outer diameter than uncuffed ETs and are used clinically with an inner ET of diameter greater than or equal to 3 mm (133). The main results of the present study were that ET leakage is

principally a problem in preterm infants when ETs less than or equal to 2.5 mm in diameter are used and for these infants cuffed ETs were not available.

5.2.3. ET leakages and volume underestimation

It is recognized that excess volume is the main factor causing VILI and hence BPD. This demonstrates the importance of monitoring V_T (106). Therefore V_T measurements during mechanical ventilation are now a clinical standard in NICUs (29). Exact knowledge of both inspired and expired gas volumes is an essential tool to apply to lung protective mechanical ventilation strategies, allowing for the optimization of ventilator settings (88).

Generally, ventilatory measurements can be performed using a low dead space flow sensor that is placed between the ET and Y-piece and which is used in almost all commercial devices for newborns (29;156). Unfortunately, this technique has disadvantages, especially in premature infants. Flow sensors placed at the airway opening are associated with (58;88):

- increased airway dead space and increased CO₂ re-breathing,
- impaired admittance to the ET and airways,
- increased contamination of the flow sensor by moisture or mucus,
- increased risk of extubation due to the weight of the flow sensor.

Several others factors can influence the quality of V_T measurement by the flow sensor in NICUs and include (58;156):

- the physical properties of the breathing gas such as FiO₂, humidity and condensed water,
- data acquisition processing and visualization,
- false breath recognition can occur whenever the flow signal is low and superimposed by disturbances (e.g. noise of the ventilator flow, flutter of the valves or water drops in the tubes),
- ET leakages.

From all the influencing factors affecting V_T measurements during mechanical ventilation, ET leakage may have the highest impact (see Chapter 5.1.1). The in-vitro

study clearly showed that an ET leakage up to 20% could be tolerated when using a Babylog 8000, but that it could lead to unacceptable volume errors if the ET leakage exceeded 40%. When the ET leakage was less than 20% the resulting volume error was less than 10% depending on the RR used (122). This is in good agreement with the volume measurements in the retrospective clinical study. As shown in Figure 4.13, a change in ET leakage of 20% caused a V_T underestimation of about 0.5 mL/kg, which is 10% of the target V_T (about 5 mL/kg). This volume error was acceptable for monitoring purposes from the clinical point of view (156). For ET leakage greater than 40% the mean V_T underestimation was 1.2 mL/kg, which is already 24% of target V_T . Such a volume underestimation can lead to erroneous clinical decisions. If, in clinical practice, a pressure adjustment to attain target V_T is performed with reference to the displayed expiratory V_T , the consequence to the lung may be over-inflation if such large ET leakage is present. As shown above preterm ventilated infants with small ETs are at a high risk of ET leakage and the resulting volume error, and this may increase the risk of BPD by volume misinterpretation. Moreover, ET leakage related volume errors can impair modern volume targeted ventilation modes. Keszler et al. (106) stated that volume targeted ventilation modes failed in the presence of substantially high ET leakage (>40%).

As shown in Figure 4.13 there was a high inter-subject variability in the relationship between ET leakage and volume difference. This may be explained by technical problems associated with leakage measurements based on the difference between inspired and expired volumes as shown in Chapter 5.1.1. In contrast to the in-vitro measurements, the measured flow signal in patients is often superimposed by spontaneous breathing, which seriously impairs the identification of the beginning and end of inspiration and expiration and the calculation of both V_T and ET leakage.

The modern modes of mechanical ventilation described in Chapter 2.2.3 use the flow signal to trigger the start of inspiration by using an adjustable flow level. The leak between the ET and the trachea can cause a pressure-dependent leak flow. This can mimic the start of inspiration of the patient and in turn can start a new cycle of the ventilator. A high leak flow or a low trigger level can lead to autocycling in flow-triggered ventilators. Bernstein et al. (16) demonstrated that ventilators with the maximum sensitivity setting of 1 mL/sec started autocycling at an ET leakage greater than or equal to 10%, but for those with decreased sensitivity settings of 3.3 mL/sec autocycling occurred at an ET leakage greater than or equal to 30%. Babylog 8000 and Stephanie

utilized a proprietary leak compensation technology that derives the instantaneous leak flow throughout the ventilator cycle and mathematically subtracts this flow from the measured value to prevent autocycling (105). Leoni used a time window of 200 ms in which after an inspiration no further inspiration can be started. To what extent such internal leak-adapted algorithms affect the volume measurements is unknown.

The standard definition of ET leakage according to Equation 1 (Chapter 5.1.1) delivers an overall ET leakage of the complete respiratory cycle. Herber-Jonat et al. (86) described a separate determination of the inspiratory ET leakage and expiratory ET leakage where they developed an algorithm to correct in the inspired and expired volume in the presence of ET leakage. In 60 mechanically ventilated infants, they showed that the correction was useful during inspiration for an ET leakage of up to 41% and during expiration up for an ET leakage of 69%. However, in clinical routine most ventilators display only the total ET leakage in percentages so that a separate correction of the inspired and expired volume is not possible.

6. Summary

Ventilated preterm infant lungs are highly vulnerable for lung over-distension, atelectasis and shear stresses, which can cause VILI and have been associated with the pathogenesis of BPD. The careful monitoring of the delivered V_T and ventilation settings are the prerequisite for a lung protective mechanical ventilation. However, V_T can be misleading in the presence of ET leakage which was not uncommon due to the widely use of uncuffed ET in mechanically ventilated neonates to protect airways

The aims of the thesis were to investigate the relationship between ET leakages and the displayed ventilatory and lung mechanics parameters by an in-vitro study using a mechanical lung model and three different ventilators. Furthermore, the incidence, extent and factors affecting the displayed ET leakage in routine clinical practice were investigated in a retrospective study using patients' medical records of mechanically ventilated neonates.

The in-vitro study was undertaken using a suitable lung model and three ventilators (Babylog 8000, Leoni and Stephanie). The ET leakage was simulated by open silicone tubes of different length. The volume delivered in the lung model was measured by an additional monitor (CO_2SMO^+) and compared with the displayed expiratory tidal volume of the ventilators. Furthermore, the lung mechanics parameters displayed by the ventilators were compared with the lung mechanics parameters of the lung model.

In the retrospective study, 163 patient records of neonates who were mechanically ventilated by Babylog 8000 for ≥ 5 h during August 2006 to December 2008 were evaluated. The infants who showed at least one ET leakage episode $>5\%$ were identified and parameters of mechanical ventilation (ventilator settings, ET leakage, V_T , and ET tube used) were recorded.

The results of both studies supplement advantageously. The in-vitro study has shown that in the presence of ET leakages the displayed expiratory V_T by the ventilators underestimated the true volume delivered in the lung for the three investigated ventilators. The volume delivered in the lung was nearly constant even with high ET leakages. Due to the dependency of the measured leakage on the RR there was no simple relationship between the displayed ET leakage and volume error. Furthermore, the relationship was highly dependent on the ventilator used. If volume errors of less than 10% are viewed as tolerable, then ET leakages of up to 20% in the Babylog 8000, 12% in Leoni and 5% in the Stephanie ventilator are acceptable.

The effect of ET leakage on the displayed lung mechanics parameters was distinctly higher in all three ventilators, but in different directions. Babylog 8000 and Stephanie ventilators overestimated the displayed compliance and resistance with increasing ET leakage and decreasing RR, whereas the Leoni ventilator underestimated the displayed compliance and overestimated the displayed resistance independent of RR. Thus, ET leakage hampers the comparability of lung mechanics measurements between different ventilators, which may be considered in clinical studies using different ventilators.

The main finding of the retrospective clinical study was that an ET leakage >5% occurred in about 75% of all ventilated neonates. However high ET leakages of >40%, with clinically relevant errors in displayed V_T , were seen at times in 42.3% of all infants receiving mechanical ventilation. Neonates with ET leakage had a statistically significant longer duration of mechanical ventilation, a shorter gestational age, lower birth weight and a higher incidence of re-intubation and mechanical ventilation. The highest ET leakages were seen in VLBW infants who were mechanically ventilated with an ET diameter less than 3 mm commonly on the third day of mechanical ventilation and not at the day of extubation. This means that for VLBW infants whom the adjustments of V_T are critical are at greatest risk for ET leakage and resulting volume errors. Cuffed ET would prevent these problems but unfortunately, they are not available for such infants.

Despite high inter-subject variability in the relationship between ET leakage and V_T the clinical study showed that an ET leakage of 40% indicated that the displayed V_T was underestimated by 1.2 mL/kg, thus by about 24% of target V_T (generally 5 mL/kg) which agrees well agreement with the results of the in-vitro study.

Both studies have clearly shown that ET leakage affects the measurement of V_T and lung mechanics, which should be considered in clinical practice. In the presence of the ET leakage there was underestimation of the displayed V_T so that any pressure adjustment to realize the target V_T may be cause over-inflated to the lung. Furthermore, a misinterpretation of lung mechanics could occur with increasing ET leakages so that the clinician would see a false improvement of lung compliance and an increase in the airway resistance which might be interpreted as an ET obstruction.

ET leakage measurement and its interpretation is not a trivial matter and differ from ventilator to ventilator. New efforts are necessary to standardize the ET leakage measurements in neonatal ventilators and to develop suitable algorithms for leakage

correction. In addition, it is quite urgent that manufacturers of neonatal ventilators describe these details and how the volume corrections were performed.

Further prospective clinical studies are necessary to investigate the effect of ET leakage on gas exchange and different treatment modalities. It is unknown as to what extent ET leakage is involved in the pathogenesis of VILI and these needs to be addressed in further studies.

Zusammenfassung

Bei beatmeten Frühgeborenen sind die Lungen sehr empfindlich gegenüber Überdehnung, Atelektasen und alveolären Scherkräften. Diese Faktoren sind auch wesentlich an der Entstehung einer *ventilator induced lung injury* (VILI) und der Pathogenese der Bronchopulmonalen Dysplasie (BPD) beteiligt. Die sorgfältige Überwachung des Beatmungsvolumens und anderer Beatmungsparameter ist daher die Voraussetzung für eine lungenschonende Beatmung. Die bei Neugeborenen üblichen ungeblockten Beatmungstuben können aber zu mehr oder weniger großen Tubuslecks führen, was das Beatmungsmonitoring erheblich beeinflusst.

Ziel dieser Arbeit war daher die in-vitro Untersuchung des Einflusses von Tubuslecks auf die Messung von Beatmungsvolumen und Atemmechanik sowie die Ermittlung der Häufigkeit und Größe von Tubuslecks und deren Einflussfaktoren durch retrospektive Auswertung von Patientenakten.

Für die in-vitro Untersuchungen wurde ein geeignetes Lungenmodell entwickelt, wobei das Tubusleck durch offene Silikonschläuche unterschiedlicher Länge simuliert wurde. Getestet wurden drei Ventilatoren (Babylog 8000, Leoni und Stephanie). Das tatsächlich in die Lunge applizierte Volumen ist mit einem zusätzlichen Monitor (CO₂SMO⁺) gemessen und mit dem angezeigten Beatmungsvolumen verglichen worden. Außerdem wurde der Einfluss des Tubuslecks auf die gemessenen atemmechanischen Parameter (Compliance, Resistance) untersucht.

Für die retrospektive Auswertung wurden insgesamt 163 Patientenakten von Kindern aus dem Zeitraum August 2006 - Dezember 2008 ausgewertet, die mit dem Babylog 8000 für mehr als 5 Stunden beatmet wurden. Wenn Tubuslecks >5% auftraten, wurden neben den Patientendaten auch Beatmungsparameter, Beatmungsvolumen, Tubusleck, Tubusgröße und Zeitpunkt des Auftretens registriert.

Die Ergebnisse beider Studien ergänzen sich vorteilhaft. Die in-vitro Untersuchungen haben gezeigt, dass bei allen Respiratoren mit zunehmendem Tubusleck das tatsächliche Beatmungsvolumen unterschätzt wird, während das in die Modelllunge applizierte Volumen nahezu leckunabhängig war. Wegen der Abhängigkeit der Leckmessung von der Inspirations- und Expirationsdauer gibt es keine einfache Beziehung zwischen dem angezeigten Leck und dem Volumenmessfehler. Außerdem war dieser Zusammenhang stark ventilatorabhängig. Akzeptiert man Volumenmessfehler bis zu 10%, so sind beim Babylog 8000 Tubuslecks bis zu 20%, bei der Leoni bis 12% und der Stephanie bis 5% tolerierbar.

Im Vergleich zur Volumenmessung waren die Auswirkungen von Tubuslecks auf die gemessenen atemmechanischen Parameter deutlich größer und bei den Respiratoren unterschiedlich. Babylog 8000 und Stephanie überschätzten Compliance und Resistance mit zunehmenden Leck und abnehmender Frequenz, während Leoni mit zunehmendem Tubusleck aber unabhängig von der Beatmungsfrequenz die Compliance unterschätzte und die Resistance überschätzte. Tubuslecks erschweren die Vergleichbarkeit atemmechanischer Messungen, was bei klinischen Studien mit verschiedenen Respiratoren berücksichtigt werden sollte.

Die retrospektive Patientenanalyse zeigte, dass Tubuslecks >5% bei 75% aller beatmenden Neugeborenen auftreten. Große Tubuslecks >40% mit klinisch relevanten Volumenmessfehlern traten zeitweise bei 42.3% aller Neugeborenen im Verlauf der Beatmung auf. Bei Neugeborenen mit Tubuslecks war die Beatmungsdauer signifikant länger, Gestationsalter und Geburtsgewicht signifikant niedriger und die Reintubationsrate signifikant höher. Die größten Tubuslecks traten bei VLBW Kindern auf, die mit einem 2.0mm oder 2.5mm Tubus beatmet wurden. Sie wurden meist am dritten Beatmungstag und nicht zum Zeitpunkt der Extubation gemessen. VLBW Kinder, bei denen das Beatmungsvolumen besonders kritisch ist, haben damit das größte Risiko für große Tubuslecks mit klinisch relevanten Volumenmessfehlern. Durch den Einsatz geblockter Beatmungstuben könnten Tubuslecks vermieden werden, allerdings sind diese für diese Altersgruppe nicht verfügbar.

Trotz hoher interindividueller Unterschiede in der Beziehung zwischen Tubusleck und Volumenmessfehler konnte mittels Korrelationsanalyse aber klar gezeigt werden, dass bei Tubuslecks von 40% das tatsächliche Volumen um 1.2mL/kg unterschätzt wird, was 24% des Zielvolumens entspricht (etwa 5 mL/kg). Dieses Ergebnis stimmt gut mit den Ergebnissen der in-vitro Untersuchungen überein.

Beide Studien haben eindeutig gezeigt, dass Tubuslecks einen erheblichen Einfluss auf die Messung von Beatmungsvolumen und Atemmechanik haben, was in der klinischen Praxis berücksichtigt werden sollte. Tubuslecks führen zu einer Unterschätzung des tatsächlichen Beatmungsvolumens. Eine Druckerhöhung zur Erreichung des Zielvolumens kann dann schnell zu einer Überblähung führen. Ebenso kann eine leckbedingte Complianceerhöhung fälschlicherweise als eine Lungenverbesserung und eine leckbedingte Resistanceerhöhung fälschlicherweise als Tubusobstruktion interpretiert werden.

Die Interpretation des gemessenen Tubuslecks ist schwierig und respiratorabhängig. Deshalb sind neue Anstrengungen zur Standardisierung der Leckmessung und zur Entwicklung geeigneter Algorithmen zur Korrektur der leckbedingten Messfehler sind. Vor allem sind Respiratorhersteller aufgefordert, die verwendeten Algorithmen zur Leckmessung und Volumenkorrektur darzustellen, so dass Messergebnisse verschiedener Respiratoren besser verglichen werden können.

Neue klinische Studien sind notwendig, um den Einfluss des Tubuslecks auf den Gasaustausch und die verschiedenen Beatmungsmodi genauer zu untersuchen. Nach wie vor ist unbekannt, welchen Anteil Tubuslecks an der Entstehung einer VILI oder BPD haben, was das Ziel zukünftiger klinischer Studien sein sollte.

7. References list

- (1) Abdel-Hady H, Matter M, Hammad A, El-Refaay A, Aly H. Hemodynamic changes during weaning from nasal continuous positive airway pressure. *Pediatrics* 2008;122:e1086-e1090.
- (2) Aghai ZH, Saslow JG, Nakhla T, et al. Synchronized nasal intermittent positive pressure ventilation (SNIPPV) decreases work of breathing (WOB) in premature infants with respiratory distress syndrome (RDS) compared to nasal continuous positive airway pressure (NCPAP). *Pediatr Pulmonol* 2006;41:875-81.
- (3) Akingbola OA, Simakajornboon N, Hadley Jr , Hopkins RL. Noninvasive positive-pressure ventilation in pediatric status asthmaticus. *Pediatr Crit Care Med* 2002;3:181-4.
- (4) Aly H. Ventilation without tracheal intubation. *Pediatrics* 2009;124:786-9.
- (5) Ambalavanan N, Carlo WA. Ventilatory strategies in the prevention and management of bronchopulmonary dysplasia. *Semin Perinatol* 2006;30:192-9.
- (6) Arul N, Konduri GG. Inhaled nitric oxide for preterm neonates. *Clin Perinatol* 2009;36:43-61.
- (7) Avery ME. Surface properties in relation to atelectasis and hyaline membrane disease. *Am J Dis Child* 1959;97:517-523.
- (8) Avery ME, Gatewood OB, Brumley G. Transient tachypnea of newborn. Possible delayed resorption of fluid at birth. *Am J Dis Child* 1966;111:380-5.
- (9) Bancalari E. Caffeine reduces the rate of bronchopulmonary dysplasia in very low birth weight infants. *J Pediatr* 2006;149:727-8.
- (10) Bancalari E, Claire N. Definitions and diagnostic criteria for bronchopulmonary dysplasia. *Semin Perinatol* 2006;30:164-70.
- (11) Bancalari E, Claire N. Weaning preterm infants from mechanical ventilation. *Neonatology* 2008;94:197-202.
- (12) Bancalari E, del MT. Continuous positive airway pressure: early, late, or stay with synchronized intermittent mandatory ventilation? *J Perinatol* 2006;26 (Suppl 1):S33-7.
- (13) Becker MA, Donn SM, Nelson M. Neonatal and pediatric pulmonary graphics: principles and clinical applications. *Pediatrics Nelson Text Book*. Armonk: Futura Publishing Co; 2008:253-77.
- (14) Becker MA, Donn SM. Real-time pulmonary graphic monitoring. *Clin Perinatol* 2007;34:1-17.
- (15) Benveniste D, Berg O, Pedersen JE. A technique for delivery of continuous positive airway pressure to the neonate. *J Pediatr* 1976;88:1015-9.

- (16) Bernstein G, Knodel E, Heldt GP. Airway leak size in neonates and autocycling of three flow-triggered ventilators. *Crit Care Med* 1995;23:1739-44.
- (17) Bhutani VK. Clinical applications of pulmonary function and graphics. *Semin Neonatol* 2002;7:391-9.
- (18) Bhutani VK. Developing a systems approach to prevent meconium aspiration syndrome: lessons learned from multinational studies. *J Perinatol* 2008;28 (Suppl 3):S30-5.
- (19) Bhutani VK, Ritchie WG, Shaffer TH. Acquired tracheomegaly in very preterm neonates. *Am J Dis Child* 1986;140:449-52.
- (20) Bhutani VK, Sivieri EM. Clinical use of pulmonary mechanics and waveform graphics. *Clin Perinatol* 2001;28:487-503.
- (21) Bissinger R, Carlson C, Michel Y, Dooley C, Hulseley T, Jenkins D. Secondary surfactant administration in neonates with respiratory decompensation. *J Perinatol* 2008;28:192-8.
- (22) Bohlin K, Gudmundsdottir T, Katz-Salamon M, Jonsson B, Blennow M. Implementation of surfactant treatment during continuous positive airway pressure. *J Perinatol* 2007;27:422-7.
- (23) Brower RG, Matthay MA, Morris A, et al. Ventilation with lower tidal volumes as compared with traditional tidal volumes for acute lung injury and the acute respiratory distress syndrome. The Acute Respiratory Distress Syndrome Network. *N Engl J Med* 2000;342:1301-8.
- (24) Brownfoot FC, Crowther CA, Middleton P. Different corticosteroids and regimens for accelerating fetal lung maturation for women at risk of preterm birth. *Cochrane Database Syst Rev* 2008;(4):CD006764.
- (25) Buhner C, Hoehn T, Hentschel J. Role of erythromycin for treatment of incipient chronic lung disease in preterm infants colonised with *Ureaplasma urealyticum*. *Drugs* 2001;61:1893-9.
- (26) Cappa P, Sciuto SA, Silvestri S. Experimental evaluation of errors in the measurement of respiratory parameters of the newborn performed by a continuous flow neonatal ventilator. *J Med Eng Technol* 2006;30:31-40.
- (27) Carlo WA. Should nasal high-frequency ventilation be used in preterm infants? *Acta Paediatr* 2008;97:1484-5.
- (28) Carlo WA, Prince LS, St John EB, et al. Care of very low birth weight infants with respiratory distress syndrome: an evidence-based review. *Minerva Pediatr* 2004;56:373-80.
- (29) Castle RA, Dunne CJ, Mok Q, Wade AM, Stocks J. Accuracy of displayed values of tidal volume in the pediatric intensive care unit. *Crit Care Med* 2002;30:2566-74.

- (30) Cheema IU, Ahluwalia JS. Feasibility of tidal volume-guided ventilation in newborn infants: a randomized, crossover trial using the volume guarantee modality. *Pediatrics* 2001;107:1323-8.
- (31) Chen JY, Ling UP, Chen JH. Comparison of synchronized and conventional intermittent mandatory ventilation in neonates. *Acta Paediatr J* 1997;39:578-83.
- (32) Chinoy MR. Lung growth and development. *Front Biosci* 2003;8:d392-415.
- (33) Claire N, Bancalari E. Methods and evidence on volume-targeted ventilation in preterm infants. *Curr Opin Pediatr* 2008;20:125-31.
- (34) Claire N, D'Ugard C, Bancalari E. Elimination of ventilator dead space during synchronized ventilation in premature infants. *J Pediatr* 2003;143:315-20.
- (35) Colaizy TT, Younis UM, Bell EF, Klein JM. Nasal high-frequency ventilation for premature infants. *Acta Paediatr* 2008;97:1518-22.
- (36) Contencin P, Narcy P. Size of endotracheal tube and neonatal acquired subglottic stenosis. Study Group for Neonatology and Pediatric Emergencies in the Parisian Area. *Arch Otolaryngol Head Neck Surg* 1993;119:815-9.
- (37) Cools F, Askie LM, Offringa M. Elective high-frequency oscillatory ventilation in preterm infants with respiratory distress syndrome: an individual patient data meta-analysis. *BMC Pediatr* 2009;9:33:39.
- (38) Crowley P, Chalmers I, Keirse MJ. The effects of corticosteroid administration before preterm delivery: an overview of the evidence from controlled trials. *Br J Obstet Gynaecol* 1990;97:11-25.
- (39) Dani C, Bertini G, Pezzati M, Cecchi A, Caviglioli C, Rubaltelli FF. Early extubation and nasal continuous positive airway pressure after surfactant treatment for respiratory distress syndrome among preterm infants <30 weeks' gestation. *Pediatrics* 2004;113:e560-e563.
- (40) Davis GM, Lands LC. Measurement of infant pulmonary mechanics: comparative analysis of techniques. *Pediatr Pulmonol* 1997;23:105-13.
- (41) Davis PG, Morley CJ, Owen LS. Non-invasive respiratory support of preterm neonates with respiratory distress: continuous positive airway pressure (CPAP) and nasal intermittent positive pressure ventilation (NIPPV). *Semin Fetal Neonatal Med* 2009;14:14-20.
- (42) De Paoli AG, Davis PG, Faber B, Morley CJ. Devices and pressure sources for administration of nasal continuous positive airway pressure (NCPAP) in preterm neonates. *Cochrane Database Syst Rev* 2008;23;(1):CD002977.
- (43) Deakins KM. Bronchopulmonary dysplasia. *Respir Care* 2009;54:1252-62.
- (44) Devlieger H, Bayet T, Lombet J, Naude S, Eugene C. The flow-pressure plot: a new look on the patient-ventilator interaction in neonatal care. *Semin Perinatol* 2002;26:425-31.

- (45) DiBlasi RM, Salyer JW, Zignego JC, Redding GJ, Richardson CP. The impact of imposed expiratory resistance in neonatal mechanical ventilation: a laboratory evaluation. *Respir Care* 2008;53:1450-60.
- (46) DiFiore JW, Wilson JM. Lung development. *Semin Pediatr Surg* 1994;3:221-32.
- (47) Dimitriou G, Greenough A, Kavvadia V, et al. Elective use of nasal continuous positive airways pressure following extubation of preterm infants. *Eur J Pediatr* 2000;159:434-9.
- (48) Donn SM. Neonatal ventilators: how do they differ? *J Perinatol* 2009;29 (Suppl 2):S73-8.
- (49) Donn SM, Nicks JJ, Becker MA. Flow-synchronized ventilation of preterm infants with respiratory distress syndrome. *J Perinatol* 1994;14:90-4.
- (50) Donn SM, Sinha SK. Newer modes of mechanical ventilation for the neonate. *Curr Opin Pediatr* 2001;13:99-103.
- (51) Donn SM, Sinha SK. Can mechanical ventilation strategies reduce chronic lung disease? *Semin Neonatol* 2003;8:441-8.
- (52) Donn SM, Sinha SK. Invasive and noninvasive neonatal mechanical ventilation. *Respir Care* 2003;48:426-39.
- (53) Dreyfuss D, Saumon G. Role of tidal volume, FRC, and end-inspiratory volume in the development of pulmonary edema following mechanical ventilation. *Am Rev Respir Dis* 1993;148:1194-203.
- (54) Edberg KE, Sandberg K, Silberberg A, Ekstrom-Jodal B, Hjalmarson O. Lung volume, gas mixing, and mechanics of breathing in mechanically ventilated very low birth weight infants with idiopathic respiratory distress syndrome. *Pediatr Res* 1991;30:496-500.
- (55) Ersch J, Roth-Kleiner M, Baeckert P, Bucher HU. Increasing incidence of respiratory distress in neonates. *Acta Paediatr* 2007;96:1577-81.
- (56) Fanaroff AA, Stoll BJ, Wright LL, et al. Trends in neonatal morbidity and mortality for very low birthweight infants. *Am J Obstet Gynecol* 2007;196:147-8.
- (57) Fidanovski D, Milev V, Sajkovski A, et al. Mortality risk factors in premature infants with respiratory distress syndrome treated by mechanical ventilation. *Srp Arh Celok Lek* 2005;133:29-35.
- (58) Figueras J, Rodriguez-Miguel JM, Botet F, Thio M, Jimenez R. Changes in TcPCO₂ regarding pulmonary mechanics due to pneumotachometer dead space in ventilated newborns. *J Perinat Med* 1997;25:333-9.
- (59) Fine GF, Borland LM. The future of the cuffed endotracheal tube. *Paediatr Anaesth* 2004;14:38-42.

- (60) Finer NN, Rich W, Craft A, Henderson C. Comparison of methods of bag and mask ventilation for neonatal resuscitation. *Resuscitation* 2001;49:299-305.
- (61) Fischer HS, Roehr CC, Proquitte H, Hammer H, Wauer RR, Schmalisch G. Is volume and leak monitoring feasible during nasopharyngeal continuous positive airway pressure in neonates? *Intensive Care Med* 2009;35:1934-41.
- (62) Fischer HS, Roehr CC, Proquitte H, Wauer RR, Schmalisch G. Assessment of volume and leak measurements during CPAP using a neonatal lung model. *Physiol Meas* 2008;29:95-107.
- (63) Foitzik B, Schmidt M, Proquitte H, Schmalisch G. Deadspace free ventilatory measurements in newborns during mechanical ventilation. *Crit Care Med* 2001;29:413-9.
- (64) Foitzik B, Schmidt M, Windstetter D, Wauer RR, Schmalisch G. Leak measurements in spontaneously breathing premature newborns by using the flow-through technique. *J Appl Physiol* 1998;85:1187-93.
- (65) Fok TF. Adjunctive pharmacotherapy in neonates with respiratory failure. *Semin Fetal Neonatal Med* 2009;14:49-55.
- (66) Fox WW, Schwartz JG, Shaffer TH. Effects of endotracheal tube leaks on functional residual capacity determination in intubated neonates. *Pediatr Res* 1979;13:60-4.
- (67) Fraser J, Walls M, McGuire W. Respiratory complications of preterm birth. *BMJ* 2004;329:962-5.
- (68) Gerstmann DR, Minton SD, Stoddard RA, et al. The Provo multicenter early high-frequency oscillatory ventilation trial: improved pulmonary and clinical outcome in respiratory distress syndrome. *Pediatrics* 1996;6:1044-57.
- (69) Goldberg A, ALeger P, Hill N, Criner G. Clinical indications for noninvasive positive pressure ventilation in chronic respiratory failure due to restrictive lung disease, COPD, and nocturnal hypoventilation-a consensus conference report. *Chest* 1999;116:521-34.
- (70) Goldsmith JP. Continuous positive airway pressure and conventional mechanical ventilation in the treatment of meconium aspiration syndrome. *J Perinatol* 2008;28 (Suppl 3):S49-55.
- (71) Graziani LJ, Spitzer AR, Mitchell DG, et al. Mechanical ventilation in preterm infants: neurosonographic and developmental studies. *Pediatrics* 1992;90:515-22.
- (72) Greenough A. Factors adversely affecting lung growth. *Paediatr Respir Rev* 2000;1:314-20.
- (73) Greenough A. Late respiratory outcomes after preterm birth. *Early Hum Dev* 2007;83:785-8.

- (74) Greenough A, Dimitriou G, Prendergast M, Milner AD. Synchronized mechanical ventilation for respiratory support in newborn infants. *Cochrane Database Syst Rev* 2008;(1):CD000456.
- (75) Gregory GA, Kitterman JA, Phibbs RH, Tooley WH, Hamilton WK. Treatment of the idiopathic respiratory-distress syndrome with continuous positive airway pressure. *N Engl J Med* 1971;284:1333-40.
- (76) Grinnan DC, Truwit JD. Clinical review: respiratory mechanics in spontaneous and assisted ventilation. *Crit Care* 2005;9:472-84.
- (77) Groenman F, Unger S, Post M. The molecular basis for abnormal human lung development. *Biol Neonate* 2005;87:164-77.
- (78) Guilherme R, Renaud C, Dommergues M, Mitanchez D. Repeat doses of prenatal corticosteroids for women at risk of preterm birth: a difficult consensus. *J Gynecol Obstet Biol Reprod* 2009;38:459-68.
- (79) Gupta S, Sinha SK, Tin W, Donn SM. A randomized controlled trial of post-extubation bubble continuous positive airway pressure versus Infant Flow Driver continuous positive airway pressure in preterm infants with respiratory distress syndrome. *J Pediatr* 2009;154:645-50.
- (80) Guthrie SO, Lynn C, Lafleur BJ, Donn SM, Walsh WF. A crossover analysis of mandatory minute ventilation compared to synchronized intermittent mandatory ventilation in neonates. *J Perinatol* 2005;25:643-6.
- (81) Halliday HL. Surfactants: past, present and future. *J Perinatol* 2008;28 (Suppl 1):S47-56.
- (82) Hallman M, Haataja R. Genetic basis of respiratory distress syndrome. *Front Biosci* 2007;12:2670-82.
- (83) Harikumar G, Greenough A, Rafferty GF. Ventilator assessment of respiratory mechanics in paediatric intensive care. *Eur J Pediatr* 2008;167:287-91.
- (84) Hascoet JM, Espagne S, Hamon I. CPAP and the preterm infant: lessons from the COIN trial and other studies. *Early Hum Dev* 2008;84:791-3.
- (85) Hayes MJ, McGregor FB, Roberts DN, Schroter RC, Pride NB. Continuous nasal positive airway pressure with a mouth leak: effect on nasal mucosal blood flux and nasal geometry. *Thorax* 1995;50:1179-82.
- (86) Herber-Jonat S, Von Bismarck P, Freitag-Wolf S, Nikischin W. Limitation of measurements of expiratory tidal volume and expiratory compliance under conditions of endotracheal tube leaks. *Pediatr Crit Care Med* 2008;9:69-75.
- (87) Hermansen CL, Lorah KN. Respiratory distress in the newborn. *Am Fam Physician* 2007;76:987-94.

- (88) Heulitt MJ, Holt SJ, Thurman TL, Hall RA, Jo CH, Simpson P. Reliability of measured tidal volume in mechanically ventilated young pigs with normal lungs. *Intensive Care Med* 2005;31:1255-61.
- (89) Hoehn T, Buhner C. High-frequency ventilation and the prevention of ventilator-associated lung injury. *Chest* 2001;119:1978-9.
- (90) Hoehn T, Krause MF, Buhner C. Inhaled nitric oxide in premature infants- a meta-analysis. *J Perinat Med* 2000;28:7-13.
- (91) Horbar JD, Badger GJ, Carpenter JH, et al. Trends in mortality and morbidity for very low birth weight infants, 1991-1999. *Pediatrics* 2002;110:143-51.
- (92) Huckstadt T, Foitzik B, Wauer RR, Schmalisch G. Comparison of two different CPAP systems by tidal breathing parameters. *Intensive Care Med* 2003;29:1134-40.
- (93) Hutchison AA, Bignall S. Non-invasive positive pressure ventilation in the preterm neonate: reducing endotrauma and the incidence of bronchopulmonary dysplasia. *Arch Dis Child Fetal Neonatal Ed* 2008;93:F64-F68.
- (94) Iriundo M, Thio M, Buron E, Salguero E, Aguayo J, Vento M. A survey of neonatal resuscitation in Spain: gaps between guidelines and practice. *Acta Paediatr* 2009;98:786-91.
- (95) Jaecklin T, Morel DR, Rimensberger PC. Volume-targeted modes of modern neonatal ventilators: how stable is the delivered tidal volume? *Intensive Care Med* 2007;33:326-35.
- (96) Jaile JC, Levin T, Wung JT, Abramson SJ, Ruzal-Shapiro C, Berdon WE. Benign gaseous distension of the bowel in premature infants treated with nasal continuous airway pressure: a study of contributing factors. *AJR Am J Roentgenol* 1992;158:125-7.
- (97) Jobe AH, Bancalari E. Bronchopulmonary dysplasia. *Am J Respir Crit Care Med* 2001;163:1723-9.
- (98) Jobe AH, Kramer BW, Moss TJ, Newnham JP, Ikegami M. Decreased indicators of lung injury with continuous positive expiratory pressure in preterm lambs. *Pediatr Res* 2002;52:387-92.
- (99) Jorgensen AM. Late preterm infants: clinical complications and risk: part two of a two-part series. *Nurs Womens Health* 2008;12:316-30.
- (100) Joshi S, Kotecha S. Lung growth and development. *Early Hum Dev* 2007;83:789-94.
- (101) Kasap B, Duman N, Ozer E, Tatli M, Kumral A, Ozkan H. Transient tachypnea of the newborn: predictive factor for prolonged tachypnea. *Pediatr Int* 2008;50:81-4.
- (102) Kattwinkel J. *Textbook of neonatal resuscitation*, 4th edn. Dallas, TX: American Heart Association. 2000.

- (103) Keszler M. Volume-targeted ventilation. *Early Hum Dev* 2006;82:811-8.
- (104) Keszler M. INSURE, Infant Flow, Positive Pressure and Volume Guarantee - Tell us what is best: Selection of respiratory support modalities in the NICU. *Early Hum Dev.* 2009;85 (10 Suppl):S53-6.
- (105) Keszler M. State of the art in conventional mechanical ventilation. *J Perinatol.* 2009;29:262-75.
- (106) Keszler M, Abubakar KM. Volume guarantee ventilation. *Clin Perinatol* 2007;34:107-16.
- (107) Keszler M, Durand DJ. Neonatal high-frequency ventilation. Past, present, and future. *Clin Perinatol* 2001;28:579-607.
- (108) Kinsella JP, Greenough A, Abman SH. Bronchopulmonary dysplasia. *Lancet* 2006;367:1421-31.
- (109) Kitterman JA. Physiological factors in fetal lung growth. *Can J Physiol Pharmacol* 1988;66:1122-8.
- (110) Klausner JF, Lee AY, Hutchison AA. Decreased imposed work with a new nasal continuous positive airway pressure device. *Pediatr Pulmonol* 1996;22:188-94.
- (111) Klimek J, Morley CJ, Lau R, Davis PG. Does measuring respiratory function improve neonatal ventilation? *J Paediatr Child Health* 2006;42:140-2.
- (112) Kondo T, Matsumoto I, Lanteri CJ, Sly PD. Respiratory mechanics during mechanical ventilation: a model study on the effects of leak around a tracheal tube. *Pediatr Pulmonol* 1997;24:423-8.
- (113) Kotecha S. Lung growth for beginners. *Paediatr Respir Rev* 2000;1:308-13.
- (114) Kotecha S. Lung growth: implications for the newborn infant. *Arch Dis Child Fetal Neonatal Ed* 2000;82:F69-F74.
- (115) Kreit JW, Sciruba FC. The accuracy of pneumotachograph measurements during mechanical ventilation. *Am J Respir Crit Care Med* 1996;154:913-7.
- (116) Kribs A, Pillekamp F, Hunseler C, Vierzig A, Roth B. Early administration of surfactant in spontaneous breathing with nCPAP: feasibility and outcome in extremely premature infants (postmenstrual age \leq 27 weeks). *Paediatr Anaesth* 2007;17:364-9.
- (117) Kuo CY, Gerhardt T, Bolivar J, Claire N, Bancalari E. Effect of leak around the endotracheal tube on measurements of pulmonary compliance and resistance during mechanical ventilation: a lung model study. *Pediatr Pulmonol* 1996;22:35-43.
- (118) Lampland AL, Plumm B, Meyers PA, Worwa CT, Mammel MC. Observational study of humidified high-flow nasal cannula compared with nasal continuous positive airway pressure. *J Pediatr* 2009;154:177-82.

- (119) Lavoie PM, Pham C, Jang KL. Heritability of bronchopulmonary dysplasia, defined according to the consensus statement of the national institutes of health. *Pediatrics* 2008;122:479-85.
- (120) Lista G, Colnaghi M, Castoldi F, et al. Impact of targeted-volume ventilation on lung inflammatory response in preterm infants with respiratory distress syndrome (RDS). *Pediatr Pulmonol* 2004;37:510-4.
- (121) Lucangelo U, Bernabe F, Blanch L. Respiratory mechanics derived from signals in the ventilator circuit. *Respir Care* 2005;50:55-65.
- (122) Mahmoud RA, Fischer HS, Proquitte H, Shalaby HA, Schmalisch G. Relationship between endotracheal tube leakage and under-reading of tidal volume in neonatal ventilators. *Acta Paediatr* 2009;98:1116-22.
- (123) Main E, Castle R, Stocks J, James I, Hatch D. The influence of endotracheal tube leak on the assessment of respiratory function in ventilated children. *Intensive Care Med* 2001;27:1788-97.
- (124) Manczur TI, Greenough A, Pryor D, Rafferty GF. Comparison of predictors of extubation from mechanical ventilation in children. *Pediatr Crit Care Med* 2000;1:28-32.
- (125) Mathur NB, Garg K, Kumar S. Respiratory distress in neonates with special reference to pneumonia. *Indian Pediatr* 2002;39:529-37.
- (126) Meberg A, Greve-Isdahl M, Heier CA. Pulmonary air-leakage in newborn infants. *Tidsskr Nor Laegeforen* 2007;127:2371-3.
- (127) Migliori C, Motta M, Angeli A, Chirico G. Nasal bilevel vs. continuous positive airway pressure in preterm infants. *Pediatr Pulmonol* 2005;40:426-30.
- (128) Miller JD, Carlo WA. Pulmonary complications of mechanical ventilation in neonates. *Clin Perinatol* 2008;35:273-83.
- (129) Moa G, Nilsson K, Zetterstrom H, Jonsson LO. A new device for administration of nasal continuous positive airway pressure in the newborn: an experimental study. *Crit Care Med* 1988;16:1238-42.
- (130) Morley CJ, Davis PG, Doyle LW, Brion LP, Hascoet JM, Carlin JB. Nasal CPAP or intubation at birth for very preterm infants. *N Engl J Med* 2008;358:700-8.
- (131) Namendys-Silva SA, Posadas-Calleja JG. Ventilator associated acute lung injury. *Rev Invest Clin* 2005;57:473-80.
- (132) Nassabeh-Montazami S, Abubakar KM, Keszler M. The impact of instrumental dead-space in volume-targeted ventilation of the extremely low birth weight (ELBW) infant. *Pediatr Pulmonol* 2009;44:128-33.
- (133) Newth CJ, Rachman B, Patel N, Hammer J. The use of cuffed versus uncuffed endotracheal tubes in pediatric intensive care. *J Pediatr* 2004 March;144:333-7.

- (134) Nikischin W, Lange M. Correction of compliance and resistance altered by endotracheal tube leaks. *Pediatr Crit Care Med* 2003;4:344-52.
- (135) Nikischin W, Lange M. Correction of compliance and resistance altered by endotracheal tube leaks and non-linear pressure/volume-relationships. *Eur J Appl Physiol* 2007;99:301-11.
- (136) Northway WH, Jr., Rosan RC, Porter DY. Pulmonary disease following respirator therapy of hyaline-membrane disease. Bronchopulmonary dysplasia. *N Engl J Med* 1967;276:357-68.
- (137) Numa AH, Newth CJ. Assessment of lung function in the intensive care unit. *Pediatr Pulmonol* 1995;19:118-28.
- (138) Obladen M. History of neonatal resuscitation. Part 1: Artificial ventilation. *Neonatology* 2008;94:144-9.
- (139) Owen LS, Morley CJ, Davis PG. Neonatal nasal intermittent positive pressure ventilation: a survey of practice in England. *Arch Dis Child Fetal Neonatal Ed* 2008;93:F148-F150.
- (140) Panda AK, Nag K, Harbottle RR, et al. Effect of acute lung injury on structure and function of pulmonary surfactant films. *Am J Respir Cell Mol Biol* 2004;30:641-50.
- (141) Pandit PB, Courtney SE, Pyon KH, Saslow JG, Habib RH. Work of breathing during constant- and variable-flow nasal continuous positive airway pressure in preterm neonates. *Pediatrics* 2001;108:682-5.
- (142) Patel D, Greenough A. Does nasal CPAP reduce bronchopulmonary dysplasia (BPD)? *Acta Paediatr* 2008;97:1314-7.
- (143) Patel DS, Rafferty GF, Lee S, Hannam S, Greenough A. Work of breathing during SIMV with and without pressure support. *Arch Dis Child* 2009;94:434-6.
- (144) Peterson J, Johnson N, Deakins K, Wilson-Costello D, Jelovsek JE, Chatburn R. Accuracy of the 7-8-9 Rule for endotracheal tube placement in the neonate. *J Perinatol* 2006;26:333-6.
- (145) Pillow JJ, Hillman N, Moss TJ, et al. Bubble continuous positive airway pressure enhances lung volume and gas exchange in preterm lambs. *Am J Respir Crit Care Med* 2007;176:63-9.
- (146) Rabec CA, Reybet-Degat O, Bonniaud P, Fanton A, Camus P. Leak monitoring in noninvasive ventilation. *Arch Bronconeumol* 2004;40:508-17.
- (147) Rademaker KJ, de Vries LS, Uiterwaal CS, Groenendaal F, Grobbee DE, van BF. Postnatal hydrocortisone treatment for chronic lung disease in the preterm newborn and long-term neurodevelopmental follow-up. *Arch Dis Child Fetal Neonatal Ed* 2008;93:F58-F63.
- (148) Ramanathan R. Optimal ventilatory strategies and surfactant to protect the preterm lungs. *Neonatology* 2008;93:302-8.

- (149) Ramanathan R, Sardesai S. Lung protective ventilatory strategies in very low birth weight infants. *J Perinatol* 2008;28 (Suppl 1):S41-S46.
- (150) Reba I. Applications of the coanda effect. *Sci Am* 1966;214:84-92.
- (151) Rehan VK, Wang Y, Sugano S, et al. In utero nicotine exposure alters fetal rat lung alveolar type II cell proliferation, differentiation, and metabolism. *Am J Physiol Lung Cell Mol Physiol* 2007;292:L323-L333.
- (152) Roberts D, Dalziel S. Antenatal corticosteroids for accelerating fetal lung maturation for women at risk of preterm birth. *Cochrane Database Syst Rev* 2006;(3):CD004454.
- (153) Rodriguez RJ. Management of respiratory distress syndrome: an update. *Respir Care* 2003;48:279-86.
- (154) Roehr CC, Schmalisch G, Khakban A, Proquitte H, Wauer RR. Use of continuous positive airway pressure (CPAP) in neonatal units- a survey of current preferences and practice in Germany. *Eur J Med Res* 2007;12:139-44.
- (155) Rojas MA, Lozano JM, Rojas MX, et al. Very early surfactant without mandatory ventilation in premature infants treated with early continuous positive airway pressure: a randomized, controlled trial. *Pediatrics* 2009;123:137-42.
- (156) Roske K, Foitzik B, Wauer RR, Schmalisch G. Accuracy of volume measurements in mechanically ventilated newborns: a comparative study of commercial devices. *J Clin Monit Comput* 1998;14:413-20.
- (157) Ruhle KH, Domanski U, Franke KJ, Nilius G. Studies of leakage measurements of automatic CPAP-devices. *Pneumologie* 2007;61:213-8.
- (158) Ryan RM. A new look at bronchopulmonary dysplasia classification. *J Perinatol* 2006;26:207-9.
- (159) Sankar MJ, Sankar J, Agarwal R, Paul VK, Deorari AK. Protocol for administering continuous positive airway pressure in neonates. *Indian J Pediatr* 2008;75:471-8.
- (160) Schibler A, Frey U. Role of lung function testing in the management of mechanically ventilated infants. *Arch Dis Child Fetal Neonatal Ed* 2002;87:F7-F10.
- (161) Schmalisch G, Fischer H, Roehr CC, Proquitte H. Comparison of different techniques to measure air leaks during CPAP treatment in neonates. *Med Eng Phys* 2009;31:124-30.
- (162) Schmalisch G, Proquitte H, Roehr CC, Wauer RR. The effect of changing ventilator settings on indices of ventilation inhomogeneity in small ventilated lungs. *BMC Pulm Med* 2006;6:20.
- (163) Schmalisch G, Wauer RR, Foitzik B, Patzak A. Influence of preterm onset of inspiration on tidal breathing parameters in infants with and without CLD. *Respir Physiol Neurobiol* 2003;135:39-46.

- (164) Schmidt M, Foitzik B, Hochmuth O, Schmalisch G. Computer simulation of the measured respiratory impedance in newborn infants and the effect of the measurement equipment. *Med Eng Phys* 1998;20:220-8.
- (165) Schmidt M, Foitzik B, Wauer RR, Winkler F, Schmalisch G. Comparative investigations of algorithms for the detection of breaths in newborns with disturbed respiratory signals. *Comput Biomed Res* 1998;31:413-25.
- (166) Schulze A. Enhancement of mechanical ventilation of neonates by computer technology. *Semin Perinatol* 2000;24:429-44.
- (167) Schulze A, Rieger-Fackeldey E, Gerhardt T, Claire N, Everett R, Bancalari E. Randomized crossover comparison of proportional assist ventilation and patient-triggered ventilation in extremely low birth weight infants with evolving chronic lung disease. *Neonatology* 2007;92:1-7.
- (168) Seidenberg J, Homberger J, Von der HH. Effect of endotracheal tube leakage on functional residual capacity determination by nitrogen washout method in a small-sized lung model. *Pediatr Pulmonol* 1994;17:106-12.
- (169) Shaffer TH, Wolfson MR, Panitch HB. Airway structure, function and development in health and disease. *Paediatr Anaesth* 2004;14:3-14.
- (170) Sharma A, Milner AD, Greenough A. Performance of neonatal ventilators in volume targeted ventilation mode. *Acta Paediatr* 2007;96:176-80.
- (171) Sherman JM, Nelson H. Decreased incidence of sub-glottic stenosis using an "appropriate-sized" endotracheal tube in neonates. *Pediatr Pulmonol* 1989;6:183-5.
- (172) Singh J, Sinha SK, Clarke P, Byrne S, Donn SM. Mechanical ventilation of very low birth weight infants: is volume or pressure a better target variable? *J Pediatr* 2006;149:308-13.
- (173) Sinha SK, Donn SM. Newer forms of conventional ventilation for preterm newborns. *Acta Paediatr* 2008;97:1338-43.
- (174) Sinha SK, Nicks JJ, Donn SM. Graphic analysis of pulmonary mechanics in neonates receiving assisted ventilation. *Arch Dis Child Fetal Neonatal Ed* 1996;75:F213-F218.
- (175) Soll R, Ozek E. Multiple versus single doses of exogenous surfactant for the prevention or treatment of neonatal respiratory distress syndrome. *Cochrane Database Syst Rev* 2009;(1):CD000141.
- (176) Soll RF. Prophylactic synthetic surfactant for preventing morbidity and mortality in preterm infants. *Cochrane Database Syst Rev* 2000;(2):CD001079.
- (177) Sreenan C, Lemke RP, Hudson-Mason A, Osiovich H. High-flow nasal cannulae in the management of apnea of prematurity: a comparison with conventional nasal continuous positive airway pressure. *Pediatrics* 2001;107:1081-3.

- (178) Stevens TP, Harrington EW, Blennow M, Soll RF. Early surfactant administration with brief ventilation vs. selective surfactant and continued mechanical ventilation for preterm infants with or at risk for respiratory distress syndrome. *Cochrane Database Syst Rev* 2007;(4):CD003063.
- (179) Sweet DG, Halliday HL. Modeling and remodeling of the lung in neonatal chronic lung disease: implications for therapy. *Treat Respir Med* 2005;4:347-59.
- (180) Thomas W, Speer CP. Nonventilatory strategies for prevention and treatment of bronchopulmonary dysplasia--what is the evidence? *Neonatology* 2008;94:150-9.
- (181) Thome U, Gotze-Speer B, Speer CP, Pohlandt F. Comparison of pulmonary inflammatory mediators in preterm infants treated with intermittent positive pressure ventilation or high frequency oscillatory ventilation. *Pediatr Res* 1998;44:330-7.
- (182) Thome U, Kossel H, Lipowsky G, et al. Randomized comparison of high-frequency ventilation with high-rate intermittent positive pressure ventilation in preterm infants with respiratory failure. *J Pediatr* 1999;135:39-46.
- (183) Van Kaam AH, Haitsma JJ, De JA, Van Aalderen WM, Kok JH, Lachmann B. Open lung ventilation improves gas exchange and attenuates secondary lung injury in a piglet model of meconium aspiration. *Crit Care Med* 2004;32:443-9.
- (184) Van Veenendaal MB, Van Kaam AH, Haitsma JJ, Lutter R, Lachmann B. Open lung ventilation preserves the response to delayed surfactant treatment in surfactant-deficient newborn piglets. *Crit Care Med* 2006;34:2827-34.
- (185) Vermillion ST, Soper DE, Bland ML, Newman RB. Effectiveness of antenatal corticosteroid administration after preterm premature rupture of the membranes. *Am J Obstet Gynecol* 2000;183:925-9.
- (186) Von Ungern-Sternberg BS, Trachsel D, Hammer J. Forced expiratory flows and volumes in intubated and paralyzed infants and children: normative data up to 5 years of age. *J Appl Physiol* 2009;107:105-11.
- (187) Wauer RR. *Surfactant therapy: Basic principles, Diagnosis, Therapy*. 1st ed. Georg Thieme Verlag Stuttgart, NY 1998;1-20.
- (188) Wiesemann HG, Vollbrandt M. A method for measuring tidal volume and lung compliance in intubated neonates in the presence of endotracheal tube leakage. *Bull Eur Physiopathol Respir* 1982;18:783-9.
- (189) Yong SC, Chen SJ, Boo NY. Incidence of nasal trauma associated with nasal prong versus nasal mask during continuous positive airway pressure treatment in very low birthweight infants: a randomised control study. *Arch Dis Child Fetal Neonatal Ed* 2005;90:F480- F483.
- (190) Zupancic JA, Hibbs AM, Palermo L, et al. Economic evaluation of inhaled nitric oxide in preterm infants undergoing mechanical ventilation. *Pediatrics* 2009;124:1325-32.

LEBENS LAUF/CURRICULUM VITAE

Mein Lebenslauf wird aus datenschutzrechtlichen Gründen in der elektronischen Version meiner Arbeit nicht veröffentlicht

Selbständigkeitserklärung

Ich, Mahmoud, Ramadan Aboelhasan Ahmed, erkläre, dass ich die vorgelegte Dissertation mit dem Thema: [*The effect of endotracheal tube leakages on the lung protective mechanical ventilation in neonates*] selbst verfasst und keine anderen als die angegebenen Quellen und Hilfsmittel benutzt, ohne die (unzulässige) Hilfe Dritter verfasst und auch in Teilen keine Kopien anderer Arbeiten dargestellt habe.“

Datum

Unterschrift

Acknowledgements

I am greatly indebted to my supervisor who continued and unlimited support made this work possible. PD Dr. Gerd Schmalisch who is abundantly helpful and offered invaluable assistance and guidance support from the initial to the final level enabled me to develop and understanding of this project. Many thanks for his effort and assistant in the setup, development, progress and revision of this work.

Deepest gratitude is also to all members of the Clinic of Neonatology, Charite Campus Mitte, Charite University for their support and helpful information during my in-vitro and clinic study. They provide many facilities, guidance and encouragement during my stay in Germany.

Prof Christoph Bühner, Prof. Roland Wauer, Dr: Hans Hammer, Dr: Hans Proquitté, PD Dr. Florian Guthmann, Dr: Charles Röhr, Dr: Malte Cremer, Dr: Sebastian Hartenstein, Dr: David Szekessy and Dr: Hendrik Fischer without whose knowledge and assistance this study would not have been successful.

The support of my Egyptian supervisors Prof Somaya Hadhood has been continuous, unlimited and invaluable. Her support to have this scholarship and flow up the progress of this thesis step by step. I would like to thank Prof Aly Abou-Elmaged the director of my home pediatric department for his continues help and support; it is my pleasure to thank Dr: Naglaa Fawzy and Hatem Shalaby for their continues support. I would also like to convey thanks to the Egyptian High Ministry of Education for providing the financial means and others facilities during my stay in Germany.

I would like to thank Jessica Blank for assistance in data processing, Regina Nagel and Silke Wilitzki for their help in facilitating the technical matters. PROOF-Reading Service.com, Hertfordshire, UK, for linguistic revision of this work.

I offer my regards and blessings to all of those who supported me in any respect during the completion of the thesis.

Lastly, it is an honor for me to thanks my mother, brothers and sisters for their unlimited help. My grateful thanks for my wife and my daughter Maryam for their continues support, encouragement and endless love during their stay with me in Berlin, Germany.