

# **ROBOBEE: A BIOMIMETIC HONEYBEE ROBOT FOR THE ANALYSIS OF THE DANCE COMMUNICATION SYSTEM**

Dissertation

zur Erlangung des Doktorgrades der Naturwissenschaften  
(Dr. rer. nat.) am Fachbereich für Mathematik und  
Informatik der Freien Universität Berlin

Tim Landgraf

2013

# **ROBOBEE: A BIOMIMETIC HONEYBEE ROBOT FOR THE ANALYSIS OF THE DANCE COMMUNICATION SYSTEM**

Dissertation

Autor: Tim Landgraf

Erstgutachter: Prof. Dr. Raúl Rojas

Zweitgutachter: Prof. Dr. Erik Cuevas, Prof. Dr. Dr. hc. Randolf Menzel

Datum der Disputation: 08.07.2013

I declare that the work in this dissertation was carried out in accordance with the requirements of the *Promotionsordnung* of the Department of Mathematics and Computer Science of Free University Berlin and that it has not been submitted for any other academic award. Except where indicated by specific reference in the text, this work is my own work. Work done in collaboration with, or with the assistance of others, is indicated as such. I have identified all material in this dissertation which is not my own work through appropriate referencing and acknowledgement. Where I have quoted from the work of others, I have included the source in the bibliography. Any views expressed in the dissertation are those of the author.

.....

Tim Landgraf

.....

Date

## **ACKNOWLEDGEMENTS**

I am indebted to Raúl Rojas. He has provided me with the right balance of freedom and guidance. I am thankful and proud to have been under his supervision for the last years. Hamid Moballegh, my dear friend and colleague, built the very first prototype of RoboBee. I am grateful for him being always there to help and talk to. My former student, Michael Oertel, who I adore for his electronics skills, is thanked substantially here. He accompanied most of the recent developments and developed the electronics of RoboBee. The whole work on the robotic honeybee and also this thesis would not have been possible without you, Michael.

The biologists I worked with also had a significant impact on the road I took for the development of the system or the experiments I conceived. Rodrigo De Marco was my mentor for the first three years. We spent hours to discuss circumstances, facts and questions in the whole bee dance universe. He opened the science world for me; kept me skeptical. Thank you for that, Rodrigo. Randolph Menzel, who I know from when I started my studies in 2001, had always an intriguing way to look at things. He is one of the most curious humans I know. Of course, I thank him for being able to participate in the radar experiments, but mostly I would like to thank him for being a driving force in the course of this project that kept things moving – although I sometimes did not agree, I always kept your opinion in mind. My dear Andreas Kirbach, with whom I spent months on the field, helped in so many ways - thanks for everything, dude. I also thank Uwe Greggers, a phenomenon, for the many excursions on physics that I never fully understood.

Six months of my doctorate I spent in California experimenting with bees in winter. I am thankful for having received a Fulbright Scholarship and am indebted to the Fulbright Commission for granting half a year of additional experiments and thesis writing. Coming to Riverside did not feel like going away from home. Kirk and Heather Visscher helped me in making myself at home, were great to talk to and to work with.

My family, Conny, Theo! ;)

Tim Landgraf

2<sup>nd</sup> April, 2013

# TABLE OF CONTENTS

Summary.....	9
<b>1 INTRODUCTION, MOTIVATION AND SCOPE OF THESIS</b>	
1.1 Motivation.....	10
1.2 Honeybees and the Dance Communication System .....	10
1.3 The Honeybee Robot .....	11
1.4 Hacking Nature and the RoboBee-Paradoxon.....	11
1.5 Structure of the thesis .....	12
1.6 Contributions.....	12
<b>2 HISTORY OF THE DANCE LANGUAGE, HONEYBEE ROBOTS AND THE FIELD OF BIOMIMETICS</b>	
2.1 The honeybee dance communication system .....	15
2.1.1 The Recruitment of Nestmates .....	15
2.1.2 Deciphering the Code of the Tail-Wagging Dance.....	16
2.1.3 Dance Language Controversy.....	17
2.1.4 The Waggle Dance: A Characterization.....	18
2.1.5 Conclusions .....	25
2.2 Previous Attempts of Building a Honeybee Robot.....	26
2.2.1 Previous honeybee robots .....	26
2.3 Animal Robots in Behavioral Biology .....	28
2.3.1 Overview of Biomimetic Robots.....	28
2.3.2 Use of Biomimetic Robots is still in its Infancy .....	29
2.4 Summary.....	31
<b>3 ANALYSIS OF THE DANCE COMMUNICATION SYSTEM</b>	
3.1 General Experimental Settings for Field Trials .....	32
3.1.1 Relevant Facts on Honeybees .....	32
3.1.2 Bees under Experimental Conditions.....	34
3.1.3 Recording Honeybee Dance Videos.....	38
3.2 Behavioral Analysis of Waggle Dances.....	40
3.3 Visual Tracking of Honeybee Dances .....	42
3.3.1 Statement of the Tracking Problem, State Description .....	42
3.3.2 Visual Features .....	42

3.3.3	Description of Properties of the Focal Animal and Respective Stable Features.....	43
3.3.4	Sparse Motion Hough Transform Clustering (SMHTC).....	45
3.4	Analysis of bee dance trajectories.....	48
3.4.1	Tracking the Videos, Resulting Trajectories and Preprocessing.....	49
3.4.2	Automatic Waggle Segmentation.....	49
3.4.3	Parameter Classes.....	50
3.4.4	General Procedure and Statistical Methods.....	51
3.4.5	Results.....	52
3.4.6	The Robotic Dance Model.....	55
3.4.7	Discussion.....	57
3.5	Characterization of Dance-Related Stimuli.....	59
3.5.1	Vibrational Signals.....	59
3.5.2	Laminar Airflows.....	61
3.5.3	Electric Fields.....	61
3.5.4	Dance pheromones.....	63
3.5.5	Secondary Stimuli Associated with the Robotic Dance.....	63
3.6	Conclusions.....	65
<b>4 DESIGN AND DEVELOPMENT OF ROBOBEE</b>		
4.1	Introduction and Preliminary Work.....	67
4.1.1	Begin of the Project.....	67
4.1.2	The RoboBee Team.....	67
4.1.3	The RoboBee-Paradoxon, Limitations and Simplifications.....	67
4.1.4	Preliminary Work.....	68
4.2	Description of RoboBee.....	70
4.2.1	Mechanics.....	70
4.2.2	Electronics.....	72
4.2.3	Position Sensors.....	74
4.2.4	Stimulus Generation.....	74
4.2.5	Central Rod and Body Design.....	78
4.2.6	Visual Obstacle Recognition.....	78
4.2.7	Graphical User Interface.....	81
4.2.8	Implementation of the Dance Model.....	82
4.2.9	Motion Control and Behaviors.....	83
4.3	Validating RoboBee.....	84

4.3.1	Motion Precision .....	84
4.3.2	Function of the Wings.....	85
4.3.3	Heat Production .....	87
4.3.4	Trophallaxis.....	87
4.4	Conclusions .....	87
<b>5 ROBOBEE IN FIELD TRIALS</b>		
5.1	Material Acceptance trials: Summer 2008.....	89
5.1.1	Experimental Design.....	89
5.1.2	Results .....	90
5.1.3	Discussion .....	91
5.2	Acquisition of the hive's scent.....	92
5.2.1	Results .....	92
5.2.2	Discussion .....	92
5.3	Behavioral Studies: Summer 2009.....	93
5.3.1	Experimental Design.....	93
5.3.2	Results .....	94
5.3.3	Discussion .....	95
5.4	Recruitment Experiments: Summer 2010.....	96
5.4.1	Design of Robot, Use of Signals.....	96
5.4.2	Experiment 1: Effect on Movement Activity.....	97
5.4.3	Experiment 2: Recruitment to Single Feeders.....	98
5.4.4	Experiment 3: Recruitment to a Known or Unknown Feeder .....	100
5.5	Recruitment Experiments: Summer 2011.....	102
5.5.1	Design Innovations -- Use of Signals.....	103
5.5.2	Experiment 1: Increasing Interest in the Robot.....	104
5.5.3	Experiment 2: Two Feeders, one Group .....	105
5.6	Conclusions .....	118
<b>6. CONCLUSIONS AND FUTURE WORK</b>		
6.1	Conclusions .....	119
6.2	Future Work, New Tools .....	120
6.2.1	Bee Facebook.....	120
6.2.2	Systematically Varying Parameters of the Dance.....	120
6.2.3	Characterization of Vibrational Signals.....	120
6.2.4	RoboBee and RoboBee 2.0.....	121

6.3	Summary of Contributions .....	121
-----	--------------------------------	-----

## SUMMARY

This thesis describes the development of a honeybee robot for the analysis of the dance communication system of the European Honeybee (*Apis Mellifera*). “RoboBee” is a tool to find out which of the stimuli produced by a dancing bee are actual signals, i.e. which stimuli are used by the follower bees to decode the message. This dissertation comprises six chapters:

First, I introduce the reader to the motivation, scope and structure of the dissertation.

Then I give a detailed overview of the key aspects of this thesis. Beginning with a short introduction to the history of waggle dance research, I report current views on the function and mechanism of the dance. In this chapter I also report on open questions in our understanding of the communication process. In the second part of the chapter, I list similar systems that were used to imitate the waggle dance. I close the chapter by report on more general examples of robots in behavioral biology.

The following chapter contains description of own preliminary work and experiments prior to building RoboBee. First, I introduce basic methods for keeping bees under experimental conditions. I outline lighting and video recording setups that I used in many works that follow up in later parts of the thesis. Then I specify details of a computer vision algorithm that I developed to track waggle dances in video recordings. Subsequently, I analyze waggle dance trajectories statistically, concluding with a computer model of the dance motion. In the last section, I describe experimental tests for the characterization of the sensory capabilities of honeybees.

After this analytical part, I give a detailed overview of the mechanics, the electronics and the software of RoboBee in a separate chapter. I review shortly a number of prototypes and conclude with the description of the final system. Each stimulus produced by the robot is characterized and compared to reference cues in the natural system. The chapter is concluded by validating and discussing RoboBee’s components.

The ultimate validation is a test in live bee colonies. In the summers 2009 – 2011 I conducted experiments to validate different functions of RoboBee. A major part of the thesis is concerned with all experimental field trials conducted in this period of time. The first experiments lead to the identification of materials that are accepted in live honeybee colonies. Following experiments address RoboBee’s ability to recruit trained and naïve bees. Each description of the experiment’s scope and setup is followed by the presentation of the results and their discussion. The final results of the summer 2011 – the following behavior of foragers and their ensuing flights - are statistically evaluated in detail by comparing natural dance following behavior with that shown with RoboBee’s dances. Flight traces of bees that displayed extensive following behavior are presented.

I conclude this dissertation by reviewing the achievements and their implications. I discuss the significance of the results and give an outlook of future experiments and possible improvements to RoboBee.

## 1.1 MOTIVATION

The honeybee dance “language” is probably the best known and most complex example of insect communication. In the animal kingdom, only a few species exhibit such an elaborate means of communication. More than six decades have gone by since its first reference as a symbolic, abstract communication system. Today, many phenomena and mechanisms stay unexplainable to the scientific world: although humans can decode the meaning and information content of a honeybee waggle dance, it remains unknown how honeybees themselves decode the message, which stimuli actually play a role and which of the many factors contribute to the complex interplay of dancer and followers we call *bee dance*.

Conveying meaningful information is vital to every living system. Whether it were single cells that are set to different states by means of semio-chemicals like pheromones - or humans using sign language to set up a date for a cup of coffee: the principle involved is *information exchange*. Without being able to communicate a system would be untethered to the world, a mute or deaf information dead end. The term communication subsumes nature’s principle strategy to embed systems into the world. One could write books about how information is exchanged in and among living beings. But still many mechanisms are unknown and remain as intriguing questions to the interested mind. This thesis focuses on just one animal and just one communication behavior that is known since many decades but still is poorly understood. It describes how this animal uses a complex symbolic communication and how the scientific world had been - and still is - investigating it. This dissertation also puts forward a way of how biological research can profit from techniques in robotics and computer science and describes the development of an example: the robotic honeybee.

There are three basic motivations for this work:

## 1.2 HONEYBEES AND THE DANCE COMMUNICATION SYSTEM

Their rich repertoire of behaviors, their sociality, their astonishing capabilities in learning and memory and their impressive versatility of communication skills make honeybees exceptional, preeminent members of the animal kingdom. Like other social insects, honeybees make heavy use of chemical and mechanical signaling. But no other insect indicates the location of newly found nest or feeding sites by performing a symbolic act, a motion that contains coordinates of a feeding site. The honeybee dance is unique and likely played an important role in their evolutionary success. The dance communication itself is not fully understood though. Although many decades of profound research have built up a huge body of knowledge, still many questions remain unanswered. What information is actually transferred between sender and receivers? How do the followers use that complex mosaic of stimuli they perceive and how are those mapped to their subsequent behavior in the field? This thesis described the development of and ensuing experiments with a robotic imitation of the waggle dance. RoboBee is used to investigate the dance differently from conventional approaches. The use of a fully controllable robot shifts the paradigm of biological investigation: Typically, external parameters are varied and the effects on the (dance) system are observed. The main motivation of building RoboBee is to enable researchers to control the dance in its many aspects.

### 1.3 THE HONEYBEE ROBOT

The idea of building a honeybee robot for the analysis of the dance communication is not new. The first to describe its possible use and potential application were John Haldane and Helen Spurway (1954):

*The question should ultimately be decided not only by further observations to test the validity of formula [...], but by experiments in which scented model bees or dead bees were mechanically moved in "dances" in which the frequency of turns and that of waggles was varied independently.*

By that time, the meaning of the dance – that it conveys information about how to find a new food source - had already been discovered. The mechanics of it, however, were still unknown. As of now, almost 60 years after Haldane and Spurway thought of a mechanical dance, many details in the dance communication still remain obscure.

The second motivation of building a functioning honeybee robot is the technical challenge. After Haldane and Spurway, others tried to build such a robot. A Danish researcher, Axel Michelsen, built an electro-mechanical model in the late 1990s and claimed this robot could recruit bees. His results were conceived quite controversially. There are no video recordings of the robot and Michelsen reported no bee was showing the stereotypical following behavior – a plausible sign for the decoding process. However, unfortunately the question whether this robot was able to recruit bees cannot be answered anymore. The robot is disassembled and the Danish PhD student that had worked on it died too young in a tragic car accident. If it is possible for a robot to send out bees, then those results should be reproducible - maybe even surpassable.

### 1.4 HACKING NATURE AND THE ROBObEE-PARADOXON

Using a robot to investigate animal communication is similar to the process of “hacking” a communication channel between computers. Many methods can be used: from simple eavesdropping (where communication is observed as in ethology) to active interference (replacing the sender to modify the message). This is probably what Feynman had in mind when he said “*What I cannot create, I do not understand.*” This is only partially true. For example, if I do not yet understand the honeybee dance, I can start with a reproduction according to initial assumptions - a preliminary model of the system. Learning from how it doesn’t work, I am well able to improve it. After several iterations I reach a sufficient understanding and eventually create a working system.

This is an intuitive and iterative process that – step by step – is able to overcome the RoboBee-Paradoxon:

*In order to understand a system, we build its reproduction – but in order to build its reproduction we have to understand the system.*

However, without initial knowledge of the biological system, it is hard to define a metric for rating a specific robot’s configuration. This is probably the biggest distinction to conventional robotics, where a system is built to solve a particular, well-defined task. The solution to it is defined by a human and thus straightforward to validate. If a robotic system is supposed to interact with a group of animals whose interaction mechanisms are unknown, the developer has to draw conclusion from observation only. Does it work? Why does it not?

My third motivation is to understand the living system and to learn generic principles and methods to apply to similar research. In the case of the honeybee dance, we want to know how bees actually decode the message, what are essential cues for the followers to decode, is the dance a broadcast signal or are the follower bees able to regulate the sender’s output? In the case of navigation in fish shoals it might be different set of questions. But are there procedural motifs? Can one find a generalized approach to it? Switching model organisms means also switching perceptual regimes. The quality and range of stimuli honeybees are able to perceive are very different to the sensory spectrum of a nightingale. The roboticist has to understand the

biological system in order to understand how to build the robotic system – for me, that is also part of the beauty of biomimetics.

## **1.5 STRUCTURE OF THE THESIS**

This thesis is structured in six chapters. This introductory chapter is followed by a thorough overview of the honeybee dance communication system reviewing the state of the art in biological and biorobotic research. I state the open questions and define a strategy how to solve them. Descriptions of previous honeybee robots are given, as well as examples of biomimetic robots that are used in behavioral biology.

The third chapter focuses on the analysis of the dance communication system. It covers the preliminary work that has been done prior to building the new honeybee robot. One section covers beekeeping methods and general procedures related to bees, since this is referred to in many parts of the thesis. Next sections cover descriptions of a video recording system for honeybee dances, the development of a video tracking program to extract the dancer's motion and the statistical analysis of the resulting trajectories. A further section will focus on preliminary tests of different stimuli in laboratory and natural conditions for the characterization of the bees' sensory capabilities.

The fourth chapter presents design and construction details of the honeybee robot. For the sake of completeness, one section shortly covers preliminary prototypes. The following section presents the full specifications of the final version of the robot. Mechanics, electronics, software and laboratory validation procedures are described here.

In the fifth chapter I describe the experimental validation. Chronologically, every chapter reports a different set of experiments given a particular configuration of the robot, starting with first experiments in 2009 and ending with the last set of field trials in the summer of 2011.

The last chapter contains the general conclusions and discussion of the results I obtained. I propose some future experiments and tools for the further investigation of the dance communication system. At last I describe work that has been done towards a new and better RoboBee 2.0.

## **1.6 CONTRIBUTIONS**

This doctoral thesis makes three major contributions:

First, a thorough analysis of waggle dances using a computer vision program is performed and an automatic variance analysis is conducted. The proposed tracking algorithm is independent of the visual appearance of the bee, can be used with different recording qualities and is robust under varying lighting conditions. The extracted dance trajectories describe the body motion of dancers in high temporal and spatial detail. The ensuing analysis yields a detailed list of dance properties including their variability. Using these properties I propose a realistic computer model of the dance that is used for the robotic imitations of the waggle dance. All results of this analysis, i.e. the video recordings, the tracking program, the dance trajectories and the source code of the dance model will be made accessible for the general public.

The design of the hardware and software for a robotic bee is the second major contribution of this thesis. The proposed system is able to move a bee replica in a Cartesian coordinate frame, reproduce the waggle dance with realistic imitations of wing vibrations, trophallactic food exchange, body scent and body heat. The robot can also react on its environment. It evades or softens collisions by reducing the motion velocity prior to an anticipated impact. It can also provide food samples automatically when animals are detected near the head or decreases the waggle amplitude when individuals come too close to the wagging abdomen. This robot is most complex and most natural honeybee robot ever built. It is also the first honeybee robot that can be operated in a closed control loop.

The third major contribution is the series of recruitment experiments in which I find that the robot not only motivates bees to forage at their previously visited sites. For the first time a honeybee robot also excites extensive following behavior, a clear indicator that those individuals try to decode the robotic dance. In a detailed comparison of robotic following and natural following behavior I give evidence that both are equivalent. Given the flight traces of a number of animals that displayed extensive following behavior it is very probable that for the first time in history bees decoded the messages of a robot.



## 2.1 THE HONEYBEE DANCE COMMUNICATION SYSTEM

A complex biological system such as a honeybee colony relies heavily on communication processes. Every tiny interaction, every odor, taste or vibration may convey meaningful information to nestmates. The information content may be comparably small for each signaling process but the sheer number of senders and receivers and the number of different messages make the beehive a complex combinatorial and yet miraculous communication epicenter. Vast numbers of different messages are shooting through the hive every minute: from broadcast chemical signals like the alarm pheromone to very distinct signals as the „tooting” of the queen that stops workers uncapping new queen cells. This thesis puts an important type of bee communication in focus: the waggle dance. This complex message, a mixture of body motion, mechanical and chemical cues, communicates the location and quality of newly found food locations to fellow nestmates. In the following chapter I picture the history of its discovery. I explain why this behavior is unique not only in the insect, but in the entire animal world and I lead over to those questions that remain still open and might be answered with the envisioned honeybee robot.

### 2.1.1 THE RECRUITMENT OF NESTMATES

An interested observer will notice that, once a honeybee has found a valuable food source, a sugar dish or a spoon full of honey, there will be soon other bees coming to help her bringing the crop home. It might take days for the first bee to find the food but only minutes for the follow-up foragers. It has long been assumed that honeybees share information of what they have been collecting outside the hive in order to convince other foragers to join. *How* they do it and *what* information is actually being communicated had been under thorough investigation for decades and still is subject to research today.

Around 2300 years ago, Aristotle reflects on this communication process. In his work „Historia Animalia” he describes the fact that a forager recruits fellow nestmates to join a foraging trip:

*On each expedition the bee does not fly from a flower of one kind to a flower of another, but flies from one violet, say, to another violet, and never meddles with another flower until it has got back to the hive; on reaching the hive they throw off their load, and each bee on his return is accompanied by three or four companions. One cannot well tell what is the substance they gather, nor the exact process of their work.*

Aristotle, Historia Animalia, XI

The German pastor Johann Ernst Spitzer was the first to describe which later would have been considered a hot lead on the way how bees recruit nestmates to remote locations. He used a “glassed hive” to observe the actions on the comb after the return of a forager:

*When a bee has come upon a good supply of honey anywhere, on her return home she makes this known in a peculiar way to the others. Full of joy she twirls in circles about those in the hive, from above*

*downward and from below upward, so that they shall surely notice the smell of honey on her; for many of them soon follow when she goes out once again.*

J. E. Spitzer, 1788<sup>1</sup>

Spitzer, a man of religion, might not have expected anything else than the odor and the first forager bee herself to lure the newcomers to the new location. The Belgian poet Maurice Maeterlinck, however, dared to dream and points out that conjoined flying might be the easiest explanation, but:

*[...] there will often be an interval of several seconds between the different arrivals. [...] Do the comrades who flock to the treasure only follow the bee that first made the discovery, or have they been sent on by her, and do they find it though following her indications, her description of the place where it lies?*

Maeterlinck was quite close as later was confirmed by the Austrian biologist Karl von Frisch who devoted his life work to the research on honeybee color vision, orientation and communication. Von Frisch was intrigued by the communication phenomenon and built an observation hive, a two framed hive with glass windows, to observe the bees' behavior like Spitzer and others before did. He set up a scented feeding station, a small dish with sucrose solution, near the hive and let a bee drink from it. Soon others came and fed from the same dish. While they were sitting and filling themselves up, he painted their thoraxes with red paint. After the sugar source was depleted the group of bees soon decreased the frequency of visiting the feeding station down to one bee once in a while. After letting one bee drink from a sugar water refill he ran back to the observation hive to find her after returning to the hive unloading the crop on the comb. In his famous book (1946) he described the wondrous ritual that followed subsequently:

*It was a fascinating spectacle when after her return home she performed a round dance, in which the red spotted bees sitting nearby showed lively interest. They tripped along after the dancer, and then left the hive to hasten to the feeding station. Soon it became apparent that the circular running is a dance of invitation, which not only recalls the former collecting group to action but also recruits new members to strengthen the working party.*

When he saw bees returning with full pollen baskets they were moving in a similar but still differentiable dance pattern he called tail-wagging dance ("Schwänzeltanz", also „waggle dance"). Von Frisch then formulated the hypothesis that waggle dances would be a means to recruit nestmates to pollen sources, whereas round dances were performed only for nectar sources (1923). Although there were critics describing contradicting observations it took von Frisch another two decades to revisit his hypothesis and eventually decode what he and many others then often called the dance "language".

### **2.1.2 DECIPHERING THE CODE OF THE TAIL-WAGGING DANCE**

Although initially having postulated the "odor-search hypothesis" in 1937 (von Frisch, 1937), in which recruitment of naïve bees relied on odors alone, von Frisch changed his mind in the 1940s. In 1944 he conducted an experiment with two feeding stations almost 180° apart at a distance of 200 m. Both feeders were scented with floral oil and were expected to attract the same amount of recruits after waggle dances were triggered to one of them. Von Frisch was intrigued when most recruits arrived at only one feeder: the one that he was using to feed the prospective dancer. A number of follow up controls made clear: not just the mere existence of a food source is communicated by the dance. Also directional information must be found in the waggle dance. By observing closely

---

<sup>1</sup> Spitzer: Ausführliche theoretische und praktische Beschreibung der Korbbienezucht, nach ausgemachten Gründen der Naturlehre und langer eigener Erfahrung. 1788.

the shape of the dances von Frisch found that all dances to one feeder are oriented the same way, i.e. the central part, the waggle run, was pointing into the same direction on the comb, whereas those dances to the other food source all pointed into the opposite direction. Seemingly, they were rotated gradually as the day went by. Von Frisch concluded that he just might have found a kind of language bees use to recruit nest mates to specific field locations.

Subsequently, von Frisch conducted many experiments to investigate and characterize the waggle dance communication. One of the most cited experiments, the “Fächer” (English: fan) experiments, made clear that - very likely - honeybees use the directional information encoded in the dance. Bees were trained to an unscented feeder 250 m away from the hive. A number of equi-distant, lavender-scented feeding sites were distributed around the hive at a distance of 200 m. Then, the central feeder was equipped with lavender oil and the sugar concentration was increased. The group of foragers acknowledged this increase by dancing. At each feeding site newcomers were recorded. The results show that most of the individuals visit those feeders that deviated less than 15 degrees from the communicated direction.

### **2.1.3 DANCE LANGUAGE CONTROVERSY**

The idea of insects having such a complex and abstract communication system was not approved easily by the scientific community. Although correlations between field site properties and dance properties exist, it cannot be concluded that they serve a function, i.e. that nest mates decode and use the information contained in the dance. There are examples in the animal kingdom where e.g. directional information is contained in body movements but do not play a (known) role in a communication process. Traditionally, insects were thought to be “lower animals” and thus could not exhibit such elaborate behaviors such as abstract, symbolic communication. Wenner and Johnson (1967) proposed that recruitment in honeybees, despite von Frisch’s results, could be explained by a simple odor search, just like von Frisch hypothesized earlier.

Throughout the last decades more and more evidence could be collected indicating that, first of all, the symbolic dance information is indeed used for finding the food source and, secondly, the use of odor *or* dance information are not exclusive search strategies: Honeybees use both given kinds of information. Still, a group of scientists criticize the proponents of the dance communication to be biased towards the language hypothesis and give alternative explanations for the observations that were favoring the dance language hypothesis. For example, a criticism towards von Frisch’s fan experiments is that the body scent of foragers could play a role in finding a food source. Since the feeder that was used to trigger the dances (“the central feeder” in the previous paragraph) was centered in the group of available test feeders the distribution of arrivals was centered too and thus might (falsely) indicate the dance would have communicated the direction.

The controversy stimulated the development of new techniques to answer to which degree olfactory and abstract information was actually used. An approach to uncouple the directional information and information describing the “odor landscape” is described in a very elegant experiment by Gould (1975). Introducing a very bright light source at one side of the observation hive lets foragers orient their dances to the light rather than to gravity. If the three ocelli (UV light receptors between the complex eyes) are covered with black paint, this switch in reference is observed only with even stronger light intensities. Those bees are not blinded; they can perfectly navigate in the field. Gould now tuned the brightness of the “artificial sun” such that the normal bees would orient their dances to the light but the treated bees wouldn’t. Dances of normal bees were triggered and ocelli-treated bees would therefore be exposed to a dance whose directional information is misdirecting. A number of test feeding stations were set up around the hive and the number of arriving recruits was recorded at each station. The results were intriguing and quite depending on the training techniques used. Were the test feeders scented with the same

scent as the training feeder the resulting distribution was almost uniform. Using a different scent than in training the directional information was used and a clear preference to the communicated feeder was found.

After decades of honeybee dance research an amazing amount of evidence has been gathered indicating that both information sources, the abstract information and the olfactory stimuli, *can* be used by the recruit. The actual decision depends on many different factors. Therefore, different experimental techniques might be leading to one or the other result.

The use of the word “language” was also often criticized since its definition is often made on the basis of human language. The term “language” thus often refers to a set of symbols and a system of grammar. Applying Peirce's definition, communication codes can be of three kinds: iconic, indexical and symbolic (Peirce, et al., 1935). While iconic information relies on the resemblance of code and entity being communicated (first order code) and indexical codes are “pointing” to the object (second order code), symbols rely on the convention of a meaning. Potentially, the dance contains indexical (e.g. the smell of the crop) and iconic codes (the wing buzzes resemble the flight to be taken). Whether some dance components serve as symbols cannot be answered based on the knowledge obtained from behavioral observations only. Obviously, honeybees share a common brain structure that maps the experience of the field trip and the hive situation to the very dance motion. That brain structure might as well be used to translate the multisensory input of a dance follower into information that is used to find the feeding spot. This common mapping function might be seen as a genetic convention and thus adds a symbolic character to the dance. In the following, I therefore stick to the term *communication system*. However, an abstract communication, like the waggle dance, that conveys information regarding temporally and spatially remote events was only found in the human. Hence, the waggle dance can be considered as quite a special behavioral trait, not only in the insect world.

#### **2.1.4 THE WAGGLE DANCE: A CHARACTERIZATION**

Upon the return from a valuable resource (nectar, pollen, resin, water or a new nest site), a forager will enter the hive and move to a certain region of the comb close to the entrance, commonly called dance floor. In the darkness of the hive, a tail-wagging forager moves on the vertical comb in an approximate figure of eight. In the central part - the waggle run - she throws her body from side to side in a pendulum-like motion pivoted approx. 1 cm in front of the head, at a frequency of about 13 Hz - 17 Hz. Throughout that run, the dancer holds tight to the comb moving forward, step by step, in a rather straight line without ceasing to waggle. Each waggle-phase is followed by a return-phase, in which the dancer circles back to the approximate starting point of the previous waggle run. Those returns are performed alternating clockwise and counter-clockwise. The shape of the dance is therefore often compared to the figure eight.

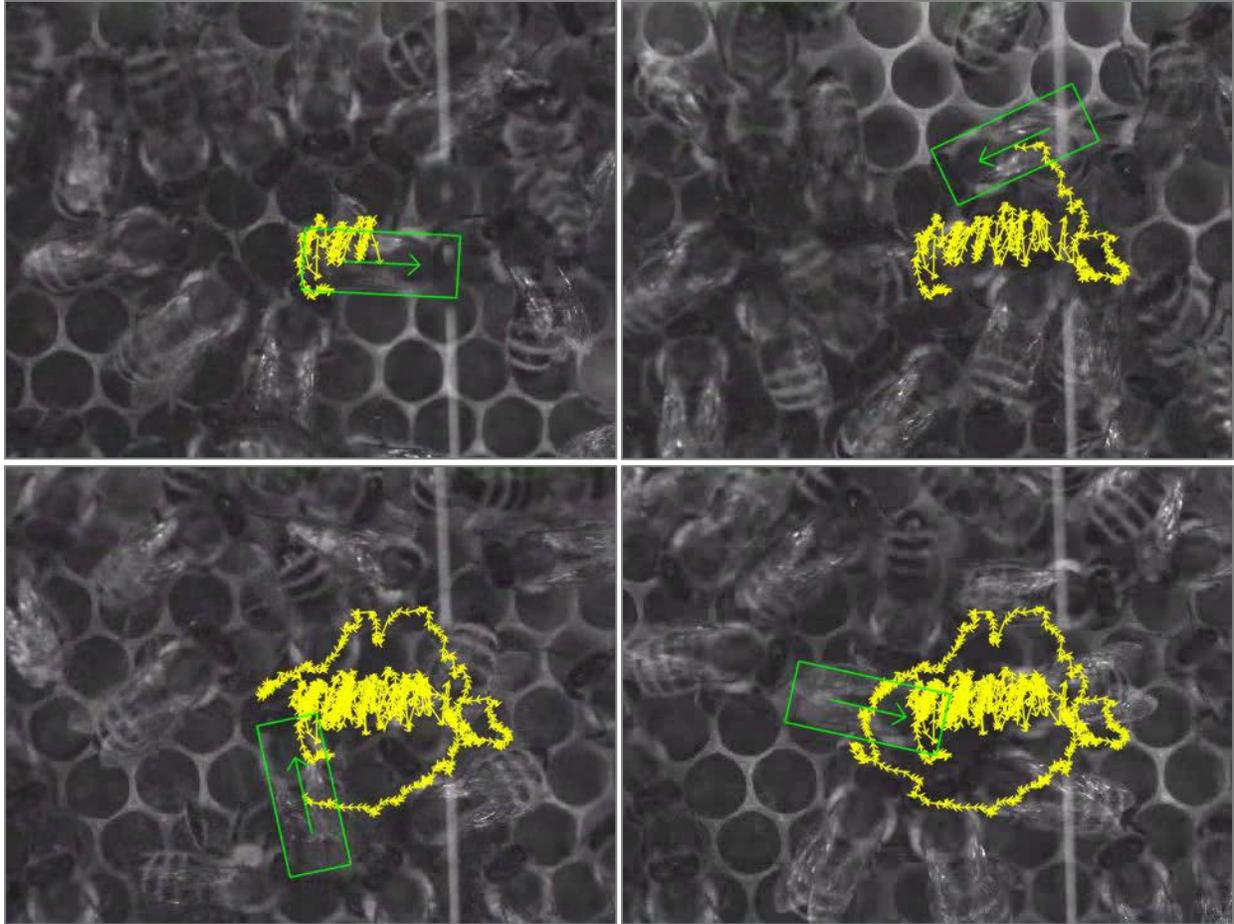

**Figure 1:** A waggle dancer (marked with a green rectangle) moves on the vertical comb forward by throwing her body from side to side (top left image). After several wagging movements she turns around (counter-clockwise in the top right image) and returns to the starting point of the previous waggle run. After the following waggle she turns in the opposite direction (to the right in the lower left image) and continues the waggle / return pattern which resembles a figure eight (bottom right image). The yellow path was obtained by marking the position of the dancing bee in every frame of a short video sequence containing a dance cycle.

Like von Frisch showed, dance parameters reflect feeding site properties. In the waggle phase, the body angle with respect to gravity approximates the direction to the feeder relative to the sun's azimuth. The length and duration of the waggle run both correlate highly with the distance to the target location (von Frisch, 1937; Seeley, 1995). In addition to direction and distance, the dance contains a measure of the profitability or quality of the food source with respect to the current hive's needs: foragers tend to dance more lively and perform longer dances (having more cycles) when feeding on a highly profitable source (Seeley, et al., 2000).

### **FOLLOWER BEES**

Follower bees, the bees standing in a close proximity to and showing interest in the movements of the dancer, are most likely to be recruited after attending several dance periods. In that process they actively pursue the dancer in order to remain in, or establish a, close contact with her. The recruitment is not a stable or reliable process. Recruits repeatedly follow dances, fly out and return to follow again until eventually only 50% of the initial followers find the food source (Mautz, 1971). Recent studies suggest that foragers prefer to follow dances carrying a previously experienced odor (Grüter, et al., 2009).



**Figure 2: The dancer (in the center) is surrounded by following and attending bees (Bozic, et al., 1991). Those bees show a typical set of behaviors, keep close contact to the dancer and receive different stimulation from her. Around 50% - 60% of the follower bees fly out after following. Again, only 60% find the communicated location after several trials.**

### **DANCES ARE RARE**

In times of a general abundance of food, dances are rarely observable (Biesmeijer, et al., 2005). Very valuable food sources though are likely to be communicated (Beekman, et al., 2008). This can be exploited in experimental designs. Artificial feeding stations offering a low concentration of sucrose might continuously be visited by foragers but are not communicated to others. High concentrations might trigger dances and thus lead to the arrival of many recruits at that feeding site. However, the quality of the artificial feeder is assessed relatively to the availability of food in general and in comparison to other natural food sources (Seeley, 1989; Seeley, et al., 1991). A sucrose solution of 1 M concentration might trigger dances by the end of the season but might fail to do so in the months of spring and early summer with many different types of trees in full bloom. Also the intensity of the food scent influences the dance frequency: the stronger the floral scents in the food the less often dances are performed in the hive (Wells, et al., 1971).

### **POTENTIAL SIGNALS IN THE COMMUNICATION PROCESS**

Follower bees detect a variety of stimuli. Mechanical cues like antenna and head contacts to the body of the dancer are frequently observable and likely transmit information about the dancer's body orientation (Bozic, et al., 1991; Rohrseitz, et al., 1999; Gil, 2010). Wing bursts in the waggle run produce complex patterns of laminar air flows, three-dimensional fields of short-ranged air particle oscillations and comb vibrations that might as well deliver meaningful multisensory input (Esch, 1961; Kirchner, et al., 1994; Tautz, 1996; Michelsen, 2003). The body temperature of dancers is significantly higher than of non-dancing foragers (Stabentheiner, et al., 1991). Recently, a dance-specific scent has been reported (Thom, et al., 2007) as yet another possible signal. Floral odors clinging to the dancer's body and regurgitated food samples are associated cues.

## MECHANICAL STIMULATION

### GENERAL BODY CONTACTS

A follower bee stays in very close contact to the dancer. In the return phase, she almost always has antennal contact to the dancer's abdomen. In the waggle phase, each wagging movement of the dancer deflects the antennae of the follower and thus creates a structured sensory input that very likely conveys information (Gil, 2010). In the return phase a follower might lose contact to the dancer which can be re-established without great search efforts. Bees might rely on mechanical, chemical or thermal stimulation for following the dancer in the dark hive.

### WING AND THORAX VIBRATIONS

The vibrations in the waggle run were independently discovered and characterized by Esch (1961) and Wenner (1962). The vibrations are produced by the flight muscles that are contracted approximately at 280 Hz in short pulses. Those pulses are repeated approximately at waggle frequency (around 15 Hz). The wings' tip to tip displacement is very small, typically not more than 1 mm (personal communication with Axel Michelsen). Follower bees might receive a very distinct mechanical stimulation by touching the vibrating body parts with their antennae. Tsujiuchi et al. (2007) shows that the Johnston organ, a collection of sensory cells in the pedicel of the antenna, is tuned to low-intensity stimulation of frequencies around 300 Hz.

### AIR PRESSURE WAVES AND OSCILLATING AIR FLOWS

The wings produce a dipole pressure which is reversed when the movement direction is changed. Moving the wings down, towards the abdomen, a positive pressure between abdomen and wings is created, and a negative pressure above the wings. Hence, air flows occur around the rim of the wings to balance this inequality. When the wing is moved back up, another airflow can be measured in the opposite direction. Essentially, this is a dipole loudspeaker, producing pressure waves and oscillating short-ranged airflows (Michelsen, et al., 1986). In the vicinity of the wings follower bees might receive meaningful stimulation without actually touching vibrating body parts.

### LAMINAR AIR FLOWS

Since the wing is vibrated radially, it pushes air towards the back of the bee. Like a fan, it creates a laminar airflow. Michelsen characterized the shape and strength of this "jet stream" in an unpublished work ("available on request" (Michelsen, 2003)). The flow is very narrow and might be perceived with the bees' mechanoreceptors (on antennae, head and body hair) even 1 cm – 2 cm behind the dancer. Michelsen's hypothesis is that follower bees might be able to calculate the waggle direction by evaluating the different temporal patterns with which they are hit by the jet.

### STATIC AND DYNAMIC ELECTRO-MAGNETIC FIELDS

Bees carry electric charges (Warnke, 1976). The wings, very dry and hardly conductive, might build up static charges in flight. When coming back to dance, the charges on the wings are oscillated in the waggle run and might produce a dynamic electric field corresponding to the frequency of the wing vibrations. This field in turn affects other charges, also those on hair and other body parts of follower bees. It seems possible that those moving charges can lead to a stimulation of mechanoreceptors on the side of the followers (Greggers, et al., submitted).

## CHEMICAL CUES

### THE WAGGLE SCENT

Thom and coworkers (2007) describe how the air above a dancing forager was analyzed using a gas chromatograph. It was shown to contain an elevated amount of four chemicals, a chemical fingerprint for dances.

Thom and coworkers could show that the number of bees that fly out the hive can be increased by adding the “waggle scent” to the hive’s atmosphere. It is unknown if this effect is an artifact (is does not relate to foraging) or if it actually serves a biological function in the dance context.

### FLORAL ODORS

Floral odors and environmental scents cling to the body of any dancer. This very rich “fingerprint” conveys information about the type of food and the smell of the environment close to the food source (Farina, et al., 2005). In the waggle dance, those chemical cues might also be used to track the dancer and have an effect on the spatial distribution of the followers around the dancer (Diaz, et al., 2007). Even floral odors alone can recruit foragers to previously learned scented food sources (Reinhard, et al., 2004).

### THERMAL CUES

(Stabentheiner, et al., 1995) characterizes the change of body temperature of foragers and dancing bees. Upon arrival at the hive, the flight muscles still warm, they are used in the dance to produce thorax and wing vibrations. The thorax stays rather hot (around 40 °C) throughout the dance and might serve as a cue to either recognize foragers in general, or track them while dancing in the darkness of the hive. An increase of body temperature causes also an elevated evaporation of cuticular chemicals (e.g. the “waggle scent” might be a result of a hot thorax). It is unclear if either the direct thermal stimulus or the connected chemical cues serve a biological function.

### FEEDBACK SIGNALS

Different behaviors, the “stop signal” and the “shaking signal”, have been discussed in playing a role in providing feedback to the waggle dance. In the context of building a robotic honeybee, it is sensible to discuss if and how the robot should be able to sense those signals.

### STOP SIGNAL

Esch (1964) described a short vibratory signal that is emitted by follower bees and that seems to make the dancers stop and deliver food samples. The signal is a 10 ms – 20 ms short burst of a carrier around 300 Hz – 400 Hz. Some bees were observed to continuously emit those bursts repeatedly at approximately 10 Hz, but typically those vibrations are emitted only once. Esch also built a mechanical model of a dancer (see page 26) which he reported was attacked when the mechanical dance continued after such a signal was emitted by a follower. Recent studies, revisiting the biological function of this signal (Nieh, 1993; Thom, et al., 2003; Seeley, et al., 2012) conclude that it serves as a negative feedback but does not elicit trophallaxis. Dancers stop wagging when perceiving the vibrations over the comb surface. The signal thus was called the stop signal. Most stop signals are produced by tremble dancers, i.e. foragers that upon arrival at the comb shake their body in a very distinct way and often search for a long time to unload their crop (Seeley, 1992) (Nieh, 1993). They emit stop signals that result in a local depression of dances and thus lead to an increase in nectar processing and decrease of the nectar influx rate (Kirchner, 1993). The stop signal seems to play a similar role in nest site selection of swarms: Dances from scouts are stopped by other scouts that found a good nest site as well (Seeley, et al., 2012).

### SHAKING SIGNAL

Another signal might have a remote importance to the robotic dance. The shaking signal, dorso-ventral vibration of a bee performed on top of another bee, was named quite differently see review by Schneider & Lewis (2004). Used in a variety of different contexts, it might increase the foraging motivation and the responsiveness to dances of foragers.

**USE OF COMMUNICATED VS. EXPERIENCED INFORMATION**

Follower bees not always use the information encoded in the dance, although they were following the dance quite extensively (Menzel, et al., 2011). Table 1 lists a number of ways a forager is able to locate a food source (following (Grüter, et al., 2009)). Even when following dances, most of the bees might use their private navigational information to locate a food source. Some parameters seem to have an impact on that decision or allow us to predict it:

**USE OF OLFATORY INFORMATION**

Olfactory information is shown to recruit bees to food sources even without following dances (Reinhard, et al., 2004). In the dance context, the forager’s private information is an important facet in the understanding of how information is used (Grüter, et al., 2009): Wenner (1969) showed that recruits have a strong preference to previously experienced scents. Even unscented dances trigger recruits to fly out but they were shown to visit rather those sites that offered a scent the bees were made familiar with in training. Following scented dances does not necessarily lead to “perfect” recruitment - Lindauer (1971) shows that half of the recruits that followed a scented dance visited similarly scented feeding sites, omitting the abstract dance information.

**NUMBER OF WAGGLE RUNS FOLLOWED**

Biesmeijer et al. (2005) shows that active foragers follow 8 waggle runs (4 circuits) in average before flying out. Mautz (1971) indicates that *successful* foragers follow 92 waggle runs in average, whereas unsuccessful foragers follow only 16 waggle runs in average. However, the relative proportion of bees that do find the target is relatively low. Only around 50% of dance followers actually leave the hive and only 60% of those bees were reported to find the feeder. Results suggest also that dance followers might not be equally effective in decoding the dance. Some bees follow more than 300 waggle runs and still do not locate the feeder. It has been shown that waggle dances or even just the odor that is associated to it reactivates the memory of previously visited sites. Completely naïve bees might also have to fly out several times and follow further waggle runs to eventually find the feeder. Recent studies (Tanner, et al., 2009; Tanner, et al., 2008) suggest that bees might integrate vector information to an average flight vector, thus reducing uncertainty by following more waggle runs. The use of harmonic radar allows to track flying honeybees on their foraging trips. Menzel et al. (2011) reports that bees following more than 20 waggle runs are very likely to use the social information and visit the new food source.

	<b>After following dances</b>	<b>Without following dances</b>
<b>Using private information</b>	<ul style="list-style-type: none"> <li>• Reactivation by dance, flying to a familiar food source</li> <li>• Reactivation by dance, flying to an empty food patch, then finding another food patch with a familiar scent nearby</li> <li>• Reactivation by dance, flying to an empty food patch and then finding another food patch nearby by random search</li> </ul>	<ul style="list-style-type: none"> <li>• Inspecting a food source that has reappeared</li> <li>• Inspecting an empty food source, subsequently searching another food source of known scent nearby, or searching randomly</li> <li>• Reactivation by olfaction</li> <li>• Reactivation by olfaction to a still-empty food source, then searching another food source of familiar scent, or novel characteristics nearby</li> </ul>

<b>Without using private information</b>	<ul style="list-style-type: none"> <li>• Using location information plus olfactory information and searching the indicated food patch</li> <li>• Using location information plus olfactory information, but then finding another food patch with the same scent</li> <li>• Using location information plus olfactory information, but then finding another food patch by random search</li> <li>• Ignoring location information, searching for plants with known scent</li> <li>• Ignoring location information and olfactory information, searching randomly for good food sources in the field</li> </ul>	<ul style="list-style-type: none"> <li>• Random search</li> <li>• Searching for plants with odors that were learned socially inside the nest</li> </ul>
--	---	---

Table 1: "How foragers can find a food source", taken from (Grüter, et al., 2009)

### REACTIVATION OF NAVIGATIONAL MEMORIES BY THE WAGGLE DANCE

Recent studies suggest that not only olfactory information reactivates a location memory but also waggle dances might serve to that purpose substantially. Biesmeijer and Seeley (2005) reported that up to 88% of following interactions accounted for a reactivation of experienced foragers. Most of those bees followed only briefly (less than 5 waggle runs), concurring with the results of Mautz (1971). Grüter et al. (2008) even reports that 93% of bees that had private information ignored the abstract dance information. Once the food at the learned location becomes less valuable or depleted, the amount of bees using the dance information increases (Grüter, et al., 2011).

### THE DECISION WHERE TO FORAGE CAN BE REVISED

Menzel et al. (2011) suggests that the decision which location a recruit visits can still be changed on the foraging trip. Once a forager exits the hive to visit either a location indicated by the abstract dance information or a previously experienced location, she might change her mind after arriving there. Some animals flew novel shortcuts between these two different sites suggesting that the complexity of the integration of both kinds of information was previously underestimated.

### OPEN QUESTIONS

The waggle dance communication has been characterized in detail. However, the coupling between the experience of the dancer and her dance movements as well as the coupling of the movements within one dance remain preserved. Which of the many stimuli actually arouse interest in following; which stimuli carry the vector information and which stimuli trigger the flight of a recruit? Is this separation of stimuli into functional categories valid? Which stimuli are essential for the information transfer and which stimuli are just by-products?

There are also questions regarding the general setting of dancing and dance following: Consider a perfect robotic reproduction of the dance. Likely, not every bee will follow and not every bee will be recruited to the food location. Which motivational states does a forager have to go through to be recruited by a dance? How exactly can the behavioral program of the dance followers be modeled; from receiving the first signal until deciding to forage at a location calculated from the complex set of stimuli perceived in the dance? Are bees becoming dance

followers irrespective of which individual is dancing? Or do dancers dance only with certain nestmates? How do they choose the dance location on the comb?

Much of the biology is not yet understood. The honeybee robot alone might not enable us to understand these processes completely but it can be of great help answering which stimuli carry information. Using the robot we can decouple the dance components. We can let the robot perform unnatural dances to observe the system under these conditions. Answers to some of the above questions seem to be prerequisites to a functioning robot bee. How can a robot excite the dance following behavior without an understanding which stimuli within the dance or motivational states of the followers are required for this phenomenon?

### **2.1.5 CONCLUSIONS**

The RoboBee-Paradoxon can be solved by iterating over the most probable configurations of stimuli and simply trying out different dances under different conditions. By exploring the communication system with small steps it should be possible to learn from the data in every cycle. This knowledge is used to improve the robot until, eventually, we have a working bee-recruiting machine.

The current knowledge described in this chapter entertains the notion that the waggle dance is neither a frequent behavior nor a perfect mechanism in terms of recruitment success and guidance precision. However, under certain circumstances (food availability in the hive and in the environment) dances become more and more frequent. So should the readiness to decode dances. All stimuli that were reported can be reproduced artificially. The technical challenge now is to embody the stimuli in an artificial bee body. Given the appropriate motivational state, potential follower bees have to track the dancing robot in the hive. They will touch it with their antennae and lick it with their proboscis. The first task should be to find materials (and treatments) that are accepted in a bee colony. Then the stimuli should be implemented and tested for acceptance in the colony. A dance with maximum resemblance to the natural reference should be used to excite following behavior and recruitment. Only then the decomposition can be done with feasible probability of success.

## 2.2 PREVIOUS ATTEMPTS OF BUILDING A HONEYBEE ROBOT

*We may be able to tell our bees to fertilize those apple trees five minutes fly to the south-east. To do this we should presumably need a model bee to make the right movements, and perhaps the right noise and smell. It would probably not be a paying proposition, but there is no reason to regard it as an impossible one.*

- J.B.S. Haldane: *The Future of Biology* (1927).

There are no exhaustive techniques available for uncoupling a dance from the experience of a forager or from the neural structures that translate the foraging experience to the body movements the dance is composed of. Without uncoupling those stimuli it is nearly impossible to decide which of the cues are responsible for the behaviors that we observe. A complete decomposition, however, is hardly possible using live honeybees. In a few studies researchers were able to control or alter one single stimulus or parameter. One study tested the recruitment success of mutant bees having short wings or having their wings cut (Kirchner, et al., 1992). Another study influenced the distance signaled in the dance by having a group of bees forage in an arena which restricted their locomotion to walking (Bisetzky, 1957). Gould (1975) changed the dance angle by using a bright light that dancers apparently mistook for the sun. However, these approaches are highly limited in the number of stimuli they control. A powerful alternative solution would be the construction of a honeybee robot that is capable of imitating each single stimulus. One would be able to test the influence of each one of them on the behavior of nestmates. This, rather old idea, formulated in the late 1920s, was attempted by several researchers. This chapter summarizes those attempts and discusses the state-of-the-art in honeybee robot research.

### 2.2.1 PREVIOUS HONEYBEE ROBOTS

Steche (1957) describes an electro-mechanical device that was used to reproduce an oscillation of 15 Hz of a cylindrical piece of wood. Steche reports that this simple waggle device could direct bees to different scented feeding sites around the hive. However, he does not show any data of these experiments and omits a thorough description of the design of his robot as well. It is unclear why the underlying data of this amazing result was withheld. It might indicate that after Steche's initial (and rather short) report he was unable to reproduce the results (von Frisch, 1967, p.104) and may have decided not to pursue this topic any further.

In the 1960s, Esch (Esch, 1964) reports (and shows a photograph of) a device that can oscillate a bee-sized piece of wood. Esch describes that the bee model could be moved manually on a waggle dance path and that bees show great interest in the model. No recruitment or following behavior was reported though.

In his PhD thesis, Gould describes attempts to use a paralyzed bee to overcome the problems posed by the mismatching chemical fingerprint of artificial materials. Gould tried to stimulate the flight muscles of the bee to reproduce the wing buzzes but never reported any recruitment success.

In the late 1980s Axel Michelsen and coworkers built the first honeybee robot that reproduced the dance sounds. The team, consisting of Danish and German researchers<sup>2</sup>, built a mechanical model of a honeybee dancer based on

---

<sup>2</sup> The engineer Bent Bach Andersen oversaw the technical development, the PhD student Jesper Storm was involved in the experiments and Wolfgang Kirchner and Martin Lindauer were experienced biologists that presumably conducted the experiments.

a plotter-like positioning system. The replica, made from brass and wax, was a little bigger than a honeybee, had a metal wing and could feed sugar drops to other bees. Michelsen et al. (1992) describes recruitment success in an experiment similar to von Frisch's fan experiments. However, many details on the experimental procedure and observations were omitted. Also the technique for registering the newcomers gives room for criticism. Since recruits were not caught at the feeding station (it is also unclear if this was because they did not land), they might have been counted more than once at also more than one feeder. Furthermore, the experiments have not been run blind, meaning that the knowledge about dance direction might have biased the counts. Since, the feeding sites were scented, the recruitment (the "persuasion" to fly out and forage) could simply be explained by the odor used in the sugar solution delivered by the robot.



**Figure 3:** A photograph of the mechanical model of a dancing honeybee, built by Michelsen and coworkers (taken from (Michelsen, et al., 1992)). The body was made of wax-coated brass, its wings from a piece of razor blade. It was able to move in a dance shaped pattern, buzz its wing and provide drops of sugar.

Michelsen's experiments were not repeated and after a fatal accident of one of his coworkers the work on the honeybee robot ceased. Fortunately, the RoboBee-Team convinced Prof. Michelsen to collaborate on a new robot.

## 2.3 ANIMAL ROBOTS IN BEHAVIORAL BIOLOGY

There are many ways of using robots to investigate animal sociality. Apart from a pure robotic setting, where group behavior might only be simulated using a group of robots in a physical environment, a powerful approach is to use robots within animal groups. As opposed to using non-interactive projections, playbacks or dummies, the methodology of using (inter-) active robots (either autonomous or controlled by a human via a remote control) matured over the last decade to a powerful toolset for biologists. Although potentially entailing a major issue of making the robot accepted by its conspecifics, it empowers researchers to vary parameters of interactions systematically and analyze the effect on the system. Moreover, the major advantage of interactivity sets robots apart from conventional studies. Interactivity ranges from single motions to sequence of motions, i.e. a robotic behavior. Contacts between robots and animals induce mechanical stimulation, chemicals can be embodied rather than just blown in the air and by feeding back sensory information, a robot might be able to react to the environment, the conspecifics or predators or prey. This chapter describes studies within this new field between robotics and biology.

### 2.3.1 OVERVIEW OF BIOMIMETIC ROBOTS

#### HYPOTHESIS-DRIVEN STUDIES

##### STUDIES OF COLLECTIVE BEHAVIOR

Halley et al. (2007) used a small wheeled robot that was exhibiting a certain scent to investigate the shelter-seeking behavior in cockroaches. The study successfully showed that cockroaches collectively decide where to find shelter and that a group of four robots could alter the decision in favor for a normally unattractive location. Faria et al. (2010) investigated group decision making of three-spined stickleback shoals using a fish robot. The robofish could recruit the shoal, i.e. initiate turns of the entire group. It is steered by a plotter below the water tank which was coupled to a fish replica via a magnet.

Göth & Evans (2004) explored the question which perceptual basis underlies the aggregation behavior in Australian brush-turkey chicks. Their robot could perform a pecking behavior and a scanning behavior using two remotely-controlled servo-motors.

The accuracy of group decision making in sticklebacks was investigated in Sumpter et al. (2008) by giving the shoal a choice between two fish replicas of different morphology. Interestingly, it was sufficient to use static images as “robots”.

##### UNCOUPLING OF MULTI-COMPONENT SIGNALS

Martins et al. (2005) studied the effect of a complex behavioral signal on different receivers with a robotic lizard. The latex lizard replica was fixed to a box integrating the electronics and a stepper motor responsible for the “headbobs”. Another study (Ord, et al., 2008) used a robotic lizard to test the hypothesis that lizards use a facultative visual alert signal (4-legged push-ups or the display of a colored dewlap) prior to signaling the main message (again a headbob). This robot used two stepper motors for the nodding movement and the extension of the dewlap.

In order to test the effect of a multi-component signal and its constituents a robotic squirrel was used to display tail wagging movements and elicit alarm calls (Partan, et al., 2009). The replica was a plastic model coated with rabbit fur sitting on a box that contained the electronics and a stepper motor for the tail wagging movements.

Using a ground squirrel robot, Rundus et al. (2007) found supporting evidence that Californian ground squirrels actively choose to add an infrared component to their defensive tail-flagging behavior when facing infrared-sensitive rattlesnakes.

In Taylor et al. (2008) robotic Túngara frog models were used to investigate the effectiveness of a multi-component signal. The robotic frogs were found to elicit an intense response to acoustic calls that were synchronized with the inflation of the vocal sac.

#### INVESTIGATION OF COURTSHIP BEHAVIOR

Patricelli (Patricelli, et al., 2002) used a three degree of freedom artificial satin bowerbird that could flap the wings, crouch, and look around. The results suggest that male bowerbirds adjust the intensity of their signals according to the female's response.

In order to test whether female fiddler crabs prefer males that wave their claws in synchrony with nearby crabs, Reaney et al. (2008) used 4 robotic fiddler crabs and found that rather the individuals that wave first and identify the synchrony as a by-product of the courtship behavior. In another study, Reaney (2009) investigated what determines the female choice by varying different parameters like claw size and wave rate of robotic crabs, which were positioned on top of a box containing the motor responsible for the claw movement.

#### EXPLORATIVE STUDIES

Motivated towards industrial applications, Böhlen (1999) investigated the possibilities and limits of introducing a freely moving robot into a group of chickens. The wheeled robot, not resembling a chicken at all, was moved among the animal group and the investigator explored possibilities to cope with anxiety resulting from this novel stimulus.

Focusing on the robotic framework, Gribovsky et al. (2010) proposes a generic experimental setup for chicken robots, including a visual tracking system for extracting motion data of the focal animals. A similar study (Takanishi, et al., 1998) proposed an experimental framework for robotic rats.

Kubinyi et al. (2004) utilize an AIBO dog robot covered with artificial fur in exploratory behavioral studies with dogs. Although dogs responded with higher interest to the dog robot compared to a remote-controlled car, limitations of the behavioral repertoire of the AIBO might explain the reduced degree of interaction compared to real dogs.

### 2.3.2 USE OF BIOMIMETIC ROBOTS IS STILL IN ITS INFANCY

Biomimetic robots are increasingly used in recent years. However, still the overall scientific output, i.e. the number of publications per year, is rather low. The types of studies indicate a clear focus on group decision making and signal perception. Besides, many explorative studies investigate frameworks that govern the general aspects of experiments rather than posing specific questions. Seemingly, there are a few issues every team has to overcome in order to construct a "successful" biomimetic robot. Apart from the communicative difficulties that every interdisciplinary project has to cope with, the complexity of the task of reaching acceptance of the robot as a conspecific depends highly on the animal or on the behavior that is studied. Sticklebacks are known to use mostly visual cues to recognize shoal members and are therefore easier to "fool". Most other studies focus on single motion behaviors, waving, nodding, etc. More complex behaviors or animal systems are simply too hard to reproduce and imitate, respectively. The field of biomimetic robots has to evolve in order to be of use for a wide spectrum of animal models.

Each robot in biological studies is special and obviously the morphology differs between those artificial animals. Besides, every system often is designed to answer a very limited set of questions. By reducing the degrees of freedom, the complexity of the whole system and thus also the complexity of the analysis of the interactions stays manageable. A recent study (Fernandez-Juricic, et al., 2006) investigates whether the display of successful foraging behavior of a house finch robot has an effect of the foraging behavior of real finches. The behavior, a simple, one degree of freedom, head-nodding, was implemented by a single motor. The replica was fixed to a ground plate and, except from the nodding, static. Other studies use more sophisticated models, like described in the previous paragraph. In the line of studies, the complexity of the robotic system seemingly predicts the focus of study: the more complex a robot is the less likely a hypothesis-driven study is undertaken. This reveals a severe dilemma every team involved in building animal robots faces: In order to understand a biological system better, it is imitated, which in order to imitate it right, has to be understood beforehand. Every study of that kind is inherently an iterative process of first exploring and then asking specific questions. It might take years to understand the system up to a certain level that would enable one to successfully imitate it. That might explain why the field of biomimetic robots is so sparsely populated.

## **2.4 SUMMARY**

This chapter describes previous work. The first section covers a thorough description of the waggle dance. For the sake of completeness, the first references of the dance are cited. Then, all known stimuli are explained and properties of the communication system are reviewed. After the report on the current state of research I conclude this section by listing open questions. This section lays the foundation of knowledge used for the design and construction of the robot as well as for the design of experiments that follow.

In a short, following section I review different existing reports on mechanical honeybees, the predecessors of RoboBee.

The last section covers existing robots used in behavioral biology.

# ANALYSIS OF THE COMMUNICATION SYSTEM

General Information on Bees, Experimental Procedures, Recording Equipment, Tracking of Dances and Motion Statistics

## 3.1 GENERAL EXPERIMENTAL SETTINGS FOR FIELD TRIALS

The following chapter covers descriptions and results of my own analyses - prior to building and testing the robot. The imitation of the dance communication assumes detailed knowledge. How do honeybees move and what would be a feasible model of this motion? What might be important stimuli, how are they produced and how could an artificial replication look like? Covering more than 6 decades of research on honeybee dance communication, the literature leaves many questions unanswered and gives ample room to start own investigations.

First of all, I recorded videos of dances. I watched thousands of them from different angles and in various temporal and spatial resolutions. Here I describe the development of a program to capture the dancer's motion. I extracted hundreds of trajectories from different dances and describe in the following the statistical analysis of those data. Based on this analysis, I propose a motion model that defines the robotic dance. Second, the analysis yields framing properties that guide the construction process of the robot. How precise is their motion? How fast do they move? How variable are particular parameters and can I learn about their respective importance in the communication process?

Secondly, the dance sounds, vibrations of the thorax and wings that occur almost exclusively in the waggle portion of the dance, are the source of a rich set of stimuli to the followers. Comb vibrations, airborne sound, continuous or alternating particle oscillations and electric fields might convey meaningful information. If they do, the robot would have to reproduce those stimuli. In order to characterize them I conducted a few tests: I recorded dance sounds to determine a parametric model for the imitation. I played back the artificial dance sounds to a colony and recorded the effect on their motion. A grid of operational amplifiers to be integrated into the comb was developed and preliminary recordings are shown to exemplify the possibility of recording and locating vibrational signals in general. Furthermore, I describe an experiment to learn about the ability of bees to recognize the "waggle scent" (Thom, et al., 2007) and report on tests I conducted to characterize the effect of all "secondary" treatments (e.g. opening and lighting of the hive).

Those analyses often require similar settings: a hive with a bee colony, training procedures for a small group of bees that are marked with paint or number tags - and video recording and storage facilities. This section describes the methods that I apply in many of the following analyses.

### 3.1.1 RELEVANT FACTS ON HONEYBEES

#### TAXONOMY

Honeybees are subsumed in the genus *Apis*. Their name derives from the trait of producing honey that is stored in the colony. In the last years I have been working with European honeybees (*Apis mellifera*), exclusively. In most field experiments Carnolian Honeybees (*Apis mellifera carnica*), the most common



those boxes, named supers, stacked on each other, each capable of containing 8-10 wooden frames. Each frame holds a matrix of hexagonal cells, which are built by the bees themselves. Such matrix can be taken out of the hive conveniently for harvesting honey and then be reused again.



Figure 5 left: A honeybee drinking sucrose solution provided by our feeding station. Right: A typical hive with two supers in the experimentation fields near Klein Lüben, Germany.

### 3.1.2 BEES UNDER EXPERIMENTAL CONDITIONS

#### OBSERVATION HIVES AND MAINTENANCE

In order to observe honeybees doing their everyday activities I use small one or two framed hives whose sides are covered with glass or transparent plastic plates, such that the surface of the comb can be overseen and filmed. Those so called observation hives are typically used in buildings that provide constant lighting and other useful facilities like power supply and network access. The bees enter and exit the hive through a hole in the wall which is connected to the hive with a tube. Observation hives contain mostly small colonies of around two thousand bees and therefore have to be maintained carefully. The livestock as well as the amount of food reserves and brood cells have to be controlled continuously. If the population decreases and there is not enough brood available to compensate one has to set in freshly emerged bees from another colony. Therefore, an incubator is used to breed larvae in a brood comb taken out of another hive before. The brood originates from a different queen - the emerged young bees are nonetheless mostly accepted in the hive they are set into. The young bees cannot sting nor fly; they can be handled with no great protection efforts. If oppositely, there are too many bees, some can be removed from the comb by simply brushing or shaking them off. Only the older, flying bees will return to the hive. This prevents colonies from swarming.

If the in-hive food supply is low, feeding sucrose solution or pollen dough supports the natural food intake. Sucrose can be fed with a bottle put head first into the hive. Its mouth piece covered with plastic foil having tiny holes pinched in. Sugar or pollen dough is commercially available and can be put any place bees can reach within the hive.

Newly arriving foragers may unload their crop and dance on both comb sides. For recording purposes I sometimes restricted dances to be performed on one side only by obstructing the ways to the backside. First a wooden wedge would lead inbound foragers to the front. The space between combs and the framing box can be stuffed with stripes of a rinse sponge or a long latch near the entrance hole. Hence, with a little more effort, bees are still able to switch comb sides, but dances are performed most of the time on the front face.

For the experiments with the robot the glass cover plate must be cut for accessing the comb surface. I used mostly acrylic plastic plates with a rectangular opening cut out near the entrance of the hive, i.e. the most likely position for dances.

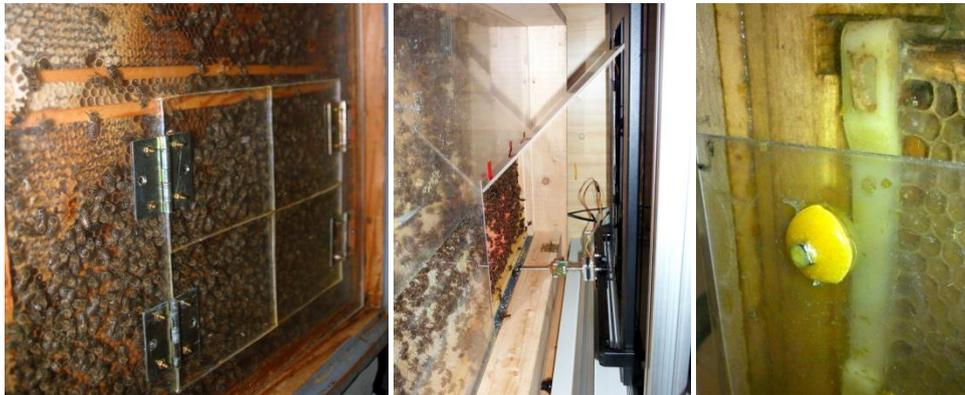

**Figure 6: Observation hives with windows. The left photograph shows a 2 x 2 window that covers the full height of a comb. The center photograph shows a simple single-door window. A magnetic lock for a single-door window is shown in the right photograph.**

For the summer of 2009 a coworker Andreas Kirbach and I have been designing a special observation hive with a matrix of 2 by 2 single sided frames. This hive was custom built to accomplish a basic goal: Bees should populate only one side of the combs in order to use the robot's vision system (described in (Landgraf, et al., 2010) and (Landgraf, et al., 2012)) for recognizing obstacles, i.e. other bees in the way of the robot's dance path. The automatic recognition relied on the back lighting of the hive to have objects on the comb cast a shadow. Bees on the backside of the comb would do as well, so this side was blocked with a thick acrylic plate.



**Figure 7: A custom 4-frame observation hive (left) was built for the summer of 2009. The frames could be backlit as to have the bees cast shadows. A typical two-frame observation hive and a single framed hive are show in the center and the right photo, respectively.**

In the fall of 2011 I built a hive with Prof. Kirk Visscher that had a moveable cover glass. This hive contained just a single frame with roughly a thousand bees. The dance floor, i.e. the area where dances take place, shifted throughout the experiments and as a reaction on that we built a rail for the cover plate. The window to the dance floor could thus be shifted along the horizontal axis.

### **LIGHTING THE HIVE**

In the hive honeybees typically dance in almost complete darkness. When I started experimenting with bees I wanted to minimize any possible disturbances in the experiments. For lighting the hive I used red and infra-red lamps (wavelengths almost invisible to honeybees (Menzel, et al., 1976)). The hives were lighted by LED cluster lamps that either radiated a particular spectrum or white light that was filtered by filter foil. In a later experiment I found that white light might disturb them for a short while but they quickly seem to adapt to the conditions and converge to normal behavior (see 3.5.5 Secondary Stimuli Associated with the Robotic Dance).

Under natural conditions bees also dance in bright daylight when swarming. After the summer of 2010 I used diffuse day or artificial white light in subsequent experiments.

### TRAINING PROCEDURES

In some experiments, I require bees to forage from a certain field location in order to

- elicit dances that announce food availability of nearly constant quality at point-like locations or
- install a memory of a location (or the action needed to get there) in a group of bees.

With the help of many students, I trained bees to artificial food sources, mostly a dish of unscented sucrose solution, by presenting it to the bees very close to the hive entrance (see Figure 8). Forager bees that by chance find the sugar source drink and search for the dish after unloading their crop in the hive. Visual markers like blue and yellow cards at the sugar dish are salient visual features and help them retracing the dish. Once a single bee keeps coming back regularly there is a high chance for her to recruit others by performing round dances. After a few minutes the feeder can be displaced in increasing step sizes farther away while the foragers sit drinking. The first steps would typically be not more than a few meters wide. Farther away from the hive the steps can be 20 m or more, depending on how feature-rich the environment of the previous step was and how long the bees were allowed to commit it to their memory. Several parameters, such as the general food supply of the hive and the existence of natural food sources might render the dressage impossible. Bees get distracted by rich natural food sources like our linden, robinia or chestnut trees. In the parts of Germany I have been training bees it is best to train bees in August and September which limits the time for experiments to only 2 months per year.

There are two approaches for making sure that bees visiting the feeder are exclusively members of the observation hive used in the experiment:



**Figure 8:** The training of honeybees is started with providing a dish of sugar water close to the hive entrance (left photograph). Drinking bees can be caught and number-tagged (center photograph). The feeder can be moved farther away step-by-step until the final location is reached.

#### FIRST APPROACH: COLOR-MARK AT FEEDER, NUMBER-TAG AT HIVE

Every new visitor to the feeder is marked with a small dot of paint on the abdomen. At the hive outgoing forager bees with a paint-mark would then be caught with a plastic tube and individually tagged with small number plates. If painted bees would come back to the feeder without being noticed at the hive they would have to be caught or killed. This is necessary not only to keep the confidence that the bees being trained are those subjected to the experiment. Foreign colonies that are usually larger than those in observation hives would likely supersede our own bees and the training would have to be started all over. This approach is fast since you might need just one forager finding her way back to the hive, dance and recruit newcomers. I have been carrying bees from the hive all the way to the feeder 250 m away, racing on my bike to let them drink a drop of sugar water there. It disturbs them quite a bit and only a tiny fraction of the bees that were carried

over actually succeed in finding back and eventually recruit bees. Once that singular event has taken place you just have to wait for the group of foragers to grow. The painting and marking though needs another person at the hive and a good set of walkie-talkies. Once a bee has left the feeder the other person at the hive has to be informed as not to miss and catch her.

#### SECOND APPROACH: NUMBER-TAG AT FEEDER

The second strategy is to mark all newcomers immediately at the feeder close to the hive until the group is large enough. Then only those marked bees are allowed to drink at the feeder which is moved away gradually as explained above.



Figure 9: Number-tagging a forager bee is done by catching it with a plastic tube which on one end is closed with a net. Once a bee is in the tube a piston helps fixating her such that the thorax is exposed through the mesh and the bee is immobilized.



Figure 10: Newly emerged bees do not sting or fly. They can be taken easily by the wings and placed on a soft sponge. A mesh or a transparent plastic plate with a hole as big as the thorax helps fixating the bee. The right sequence of images shows how the number tags are placed in different angles on the back of the bee to obtain a higher number of combinations.

#### MARKING BEES WITH NUMBER TAGS

To be able to individually identify trained bees I use plastic number tags. They are commercially available and usually serve beekeepers to mark queens in order to track them down quickly in large colonies. The number tags usually come in five different colors and exhibit a two-digit number in black or white. There are many ways of gluing the tag to a bee's thorax. The safest way is to catch a drinking forager with a special transparent plastic tube that is shown in Figure 9 and subsequently called "Pömpel". Once the bee is in the tube a piston covered with a soft sponge can be used to push the bee against a net at the other side. Immobilized, she then exposes her thorax through the mesh. Now, a toothpick is used to apply a small amount of shellac to the thorax. It is important to remove most of the hair since otherwise the plate is more likely to come off prematurely.

Marking freshly emerged bees is a time consuming yet important task for some experiments. Using the tube for marking is not fast enough and since the young bees do not sting nor fly one might take the mesh off of the tube and use it to fixate a bee on a bigger sponge. One might alternatively drill a hole in a thin plastic plate and glue the number plate to the thorax through that hole. Figure 10 depicts an example. The experienced bee scientist might just grab the bee by one of her wings and glue the tag holding her with one hand.

Once marked, the bee is released or, if a young bee, put in the hive. I refer to individual bees in a special notation throughout the thesis: First, the color is denoted by one or two lowercase characters, followed by the two-digit ID. To increase the number of discriminable individuals I use the rotation of the tag in 4 discrete steps (0°, 90°, 180°, 270°) as a third dimension. It is easier for the observer to note where the base line of the number tag is as opposed to read the correct angular orientation. Therefore I use the postfixes “L”, “R”, “T” and “B” to express from which side of the bee the number tag can be read (see Figure 10). For example the ID “ny62b” refers to bee “neon yellow 62, baseline is bottom”.

**Table 2: Abbreviations of number tag colors.**

<b>w:</b>	White	<b>b:</b>	Blue	<b>nb:</b>	Neon Blue
<b>r:</b>	Red	<b>g:</b>	Green	<b>ng:</b>	Neon Green
<b>p:</b>	Pink	<b>y:</b>	Yellow	<b>ny:</b>	Neon Yellow

### 3.1.3 RECORDING HONEYBEE DANCE VIDEOS

In order to learn about key features of the dance and to be able to define target properties of the robot I video-recorded hundreds of dances and analyzed the waggle dance motion – first manually by observation, then with an automatic tracking program and an ensuing analysis of the tracking data. In the summers 2005, 2006 and 2008 I recorded dances from individually marked dancers. They were trained to an artificial food source 215 m distant from the hive (see page 36 for a description of training procedures). The goal was to create a database of dance recordings of known field locations for further analyses. In the years 2009, 2010 and 2011 I recorded the interaction of bees and the robot. All recording setups share similar requirements to which I describe my approach in the following.

#### HIVE, LIGHTING AND CAMERA

For the video recordings common two-frame observation hives were used as described above. They were populated with approximately 2000 bees and were placed into a small wooden hut (“the bee house”) which could provide constant lighting conditions, power supply and access to the corporate network. For the dance recordings I used only weak red light. For both the lights and the camera I used commercial holders with three degrees of freedom (“MagicArm”) that can be fixed to a table with a screw clamp (see picture). The recordings were made with a Basler A602f greyscale camera at VGA resolution. The maximum frame rate at that resolution was 121 Hz. For most recordings 100 fps were used. Grey value resolution was set to 8 bit. The camera was interfaced by IEEE1394 (“FireWire”). For most of the recordings a Pentax C2514-M lens was used.



**Figure 11:** For the behavioral recordings I used different lighting devices. The left image shows an infrared lamp that is commercially available. Both, cameras and lamps are placed using grip holders, such as the “Magic Arm”, depicted in the center photograph. For most recordings a Basler A602f was used, as shown in the right picture.

#### RECORDING SOFTWARE, COMPRESSION SETTINGS

There was no program available to record from the Basler camera. I programmed a custom recording application that was fast enough to record the video stream from the camera at high frame rates to the hard disk. It basically runs two threads, one copying new frames from the camera to a ring buffer in RAM and the other writing those raw frames to disk. The program uses the CMUcam API developed at Carnegie Mellon

University for interfacing the camera. This API basically gives access to generic IEEE1394 camera devices. The code can be found in the project's repository [www.robobee.eu/dissertations/landgraf](http://www.robobee.eu/dissertations/landgraf).

Since on-the-fly compression would have suppressed the frame rate the transcoding from raw to a compressed format had to take place after the recording. I experimented with many codecs and found the lossless codec "Lagarith" to be feasibly fast and compressive. The raw files on the computer that was used in the bee house were compressed and moved to a server over a network connection overnight.

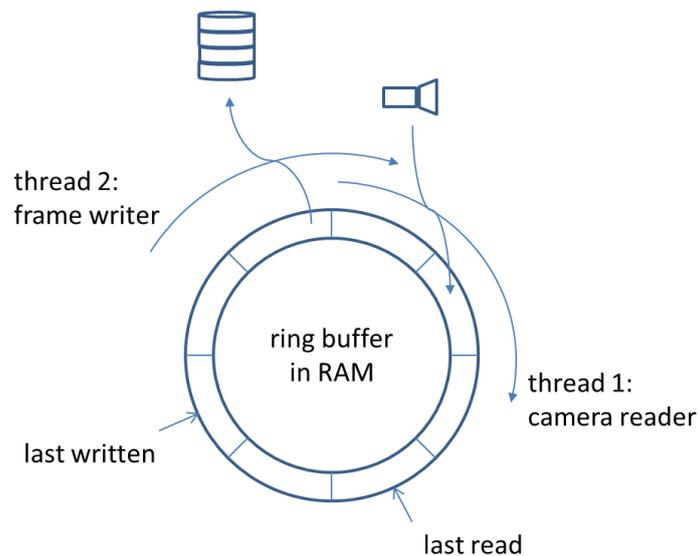

Figure 12: The figure above shows the schematics of my recording program. Two threads run in parallel. The camera reader stores new frames from the camera into a ring buffer in the computer's memory. It continuously overwrites frames that were previously written to the hard drive by the frame writer thread. Two pointers indicate the last positions both threads worked at. The camera reader cannot write past the "last written" position. If it would, the writer would lose a sequence of frames that is as long as the ring buffer is. The writer itself cannot go past the "last read" position, or otherwise would write old frames to disk again.

## IMAGE QUALITY

The first recordings of waggle runs were blurry due to the low lighting and high exposure that was hence necessary. To improve image quality I added more red light LED cluster lamps. I arranged the clusters in a circle around the camera which provided sufficiently diffuse but still strong light at the scene. The reflections on the wings were diminished but did not fully disappear. In the year 2009 I experimented with backlighting proposed originally by an Argentinian coworker and friend Juan Gurevitz. The backlighting provides an excellent silhouette of the body. This however is traded with the loss of texture on the body. For less densely packed hives this might be an alternative for recording behavior. All body parts like antennae and proboscis are very well seen in those recordings. This lighting technique is also used for the robot's reactive vision system described in Chapter 4.

## RECORDINGS OF COLLABORATORS

I could get hold of other video recordings of honeybee behavior. I was put in contact with Professor Michelsen and Professor Esch who provided me with some of their recordings, both of which were very valuable for learning about different aspects of the dance. Prof. Michelsen used a prism attached to the camera and close to the comb surface to obtain images from the sides. This provides image material on how the bees walk on the cells and how their abdomen swings above the comb. Axel Michelsen also moved the camera quite close to the dancer to obtain full detailed images of even antennal motion. Though, he had to move the camera with the dancer. Therefore, I could not use these recordings for the tracking task; they lack a global reference point.

Professor Harald Esch provided recordings taken with a thermo camera. Those videos visualize the difference in body temperature of dancers and other bees.

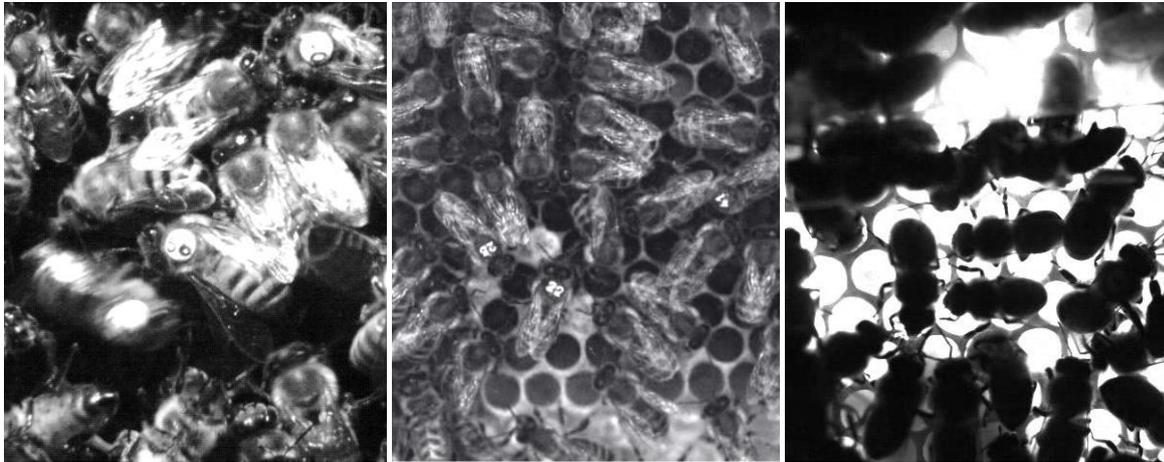

Figure 13: In the analyses I used different recordings that all had different qualities. The first recordings were blurry and exhibited many reflections that complicated the tracking. In the following summer, I recorded a new set of videos that, due to the more diffuse lighting, had fewer reflections (center image). Some recordings were taken using back-illumination (right image).



Figure 14: The left image shows a frame of one of Prof. Michelsen's video recordings. He used a prism to observe the sides of a dancing bee. In the right image, a thermo-camera was used to capture the body temperatures of workers, foragers and dancers. This image was kindly provided by Harald Esch.

### STORAGE OF VIDEO AND META DATA

Since 2005 I recorded honeybee dances or other bee related videos. Throughout the years I accumulated 250 GB of video data, many of which my analyses rely on. The storage and backup of these videos was done first on a RAID-5 system with 4 hard disks each of the size of 1TB. Later a content management system was developed in the RoboBee group by Thomas Schwaier (2010). It was installed on a web server to a) store the videos in the original (losslessly compressed) and a compressed format for fast web-based viewing and b) store meta data such as associated experimental data or post-experimental data such as the dance trajectories I describe in the following section. The system is currently refurbished to be used publicly to share the results of this research.

## 3.2 BEHAVIORAL ANALYSIS OF WAGGLE DANCES

I reviewed dance recordings frame by frame to learn about behavioral parameters of dancers and followers. The waggle motion is not as rigid as was described in the literature. Bees have to walk forward on the comb

that is not a flat surface. They take steps to move their wagging body forward but might not be able to maintain a continuous and smooth motion all the time. So at many occasions within the waggle phase the continuous wagging motion or the continuous forward motion could be interrupted for a short time of 10-30 milliseconds. I observed dancers interrupting their wagging in the middle of a waggle run to either walk some steps further to continue wagging or to initiate the return run right away. They might also waggle in curved trajectories or while in a return run. Those behaviors are rather rare and might not play an important role.

Bees dance in a very dense and chaotic environment. Moving a comparably heavy robot in a bee colony will produce collisions. This might impair the motivation of nestmates to follow the instructions of RoboBee. I therefore watched the dance recordings asking how often and severe natural collisions occur and how they are handled by the individuals involved.

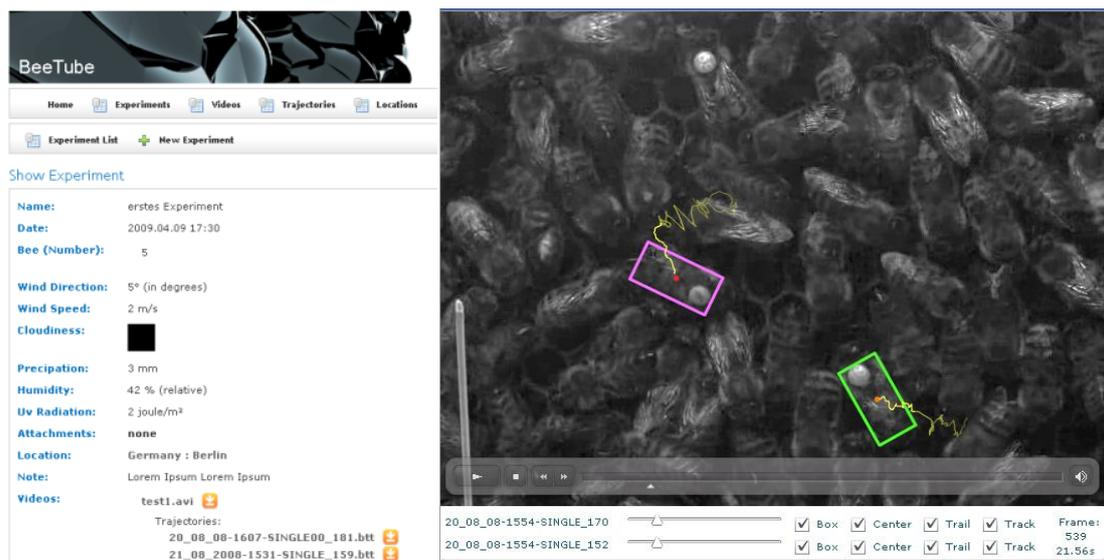

**Figure 15:** The video management system “BeeTube” was developed by Thomas Schwaier and essentially is a web-page to which videos and associated meta-data can be uploaded to. The left image shows a screenshot of a web page that integrates data for a certain experiment. Date, weather conditions, video recordings and trajectories can be associated to one dataset. Trajectories can be viewed as an overlay on the video recording with a custom Flash plugin.

I reviewed approx. 200 dances and classified all collisions into 4 categories:

- Waggle collisions – the dancer hits other bees when performing the waggle run. The followers are hit frontally against the antennas and the head by the dancer’s abdomen or the dancer runs into another bee frontally.
- Return run collisions – the dancer runs into a follower or uninvolved bee with the head or while turning the dancer hits another nearby bee with the sides.
- Follower collisions – a follower searching for the dancer runs into her or other followers.
- Pass-by collisions – bees passing by the dance area hit others with the head.

There are many more body contacts that do not fall in any of those categories. I consider collisions to significantly change the movement vector of the involved individuals. This includes a change of direction and/or stopping. All collisions have in common, that no rebound can be observed. The mass and velocity of each individual is comparable. The impact energy gets dampened by the legs, a flexible coupling to the comb surface. The dancer also actively draws aside in return runs. In waggle runs, conversely, there is almost no evasion. The dancer does not change the waggle direction for avoidance of collisions. Some collisions might also be beneficial for the decoding process. In high resolution recordings it is easily observable that follower bees try to establish a close contact to the dancer’s abdomen. The antennae are continuously hit by the dancer’s body. The abdomen bounces often into the head of the followers that are not retreating as to avoid this. They rather follow her maintaining approximately the same distance. The amount of kinetic energy of an

impact with a wagging robot is presumably far higher. There are two possible ways of preventing severe collisions:

1. An active approach: the imminent collision is sensed and prevented actively by altering the dance trajectory, as described in Chapter 4.
2. A passive approach: the impact energy is reduced by a soft body material of the robot. Accordingly material testing trials are described in Chapter 5.

### **3.3 VISUAL TRACKING OF HONEYBEE DANCES**

The following analysis focuses on the body motion of dancers. In order to build a computer model, real dances were subjected to a statistical variance analysis to learn about the most important parameters of the dance motion. The data basis, i.e. planar positions and the body angle for every video frame, is created by a computer vision program. The underlying algorithms are described in the following section. Some of the work has been described previously (Landgraf, et al., 2007).

In the course of the years I tested different publicly available tracking algorithms (Viola, et al., 2001; Cootes, et al., 2001; Kalal, et al., 2010) for tracking bees (Risse, 2007; Schmidt, 2008; Landgraf, in prep). For the present analysis of honeybee dances a different algorithm was used and is therefore described in the following section.

#### **3.3.1 STATEMENT OF THE TRACKING PROBLEM, STATE DESCRIPTION**

Generally, tracking is defined as the task to relocate an object in a new video frame given an initial or the previous position. In the bee dance videos there are 20 to 50 bees visible in an arbitrary video frame and they all might run over each other, occluding the animal in focus. A tracking algorithm relies on:

- The model and state representation of the bee
- A method to measure the fit the model on the new image
- A method to find correspondences between detections in different time points

In order to track a bee its state must be represented feasibly. The number of state parameters should be as low as possible since more parameters span a larger search space. For the dance analysis we are interested in essentially three dimensions: planar position and body orientation. However, this is just a guess. Bees exhibit a slight roll along the longitudinal axis in the waggle run and bend their body in the return portion. This might be of importance to the follower bees. If so, it should be reflected by the choice of the state representation and the design of the robot. For this analysis, however, only the abovementioned three dimensions are used.

The animal might be modeled more complex, depending on the method to detect it in a new image. The model could be a template image or a set of parameters that describe the bee's contour. The basic detection (and tracking is a kind of detection) relies on visual features that are specific to the animal.

#### **3.3.2 VISUAL FEATURES**

I watched hundreds of dance videos numerous times before designing the final tracking algorithm to learn which visual features bees exhibit. What parts of the bee body are salient and recognizable in the camera image, robustly extractable, independently of changing lighting and recording conditions? Technically, a visual feature is a particular subset of the image of the object. It might be defined as an image patch, a set of pixels that correspond to body parts that are stable under a number of transformations. Those would typically include translations, rotations, scaling, lighting changes and alike. The definition of visual features though is not limited to the image space. Features might be found in the frequency space or along the time axis as well.

An image is a matrix of numbers, or, if it was a color image, 3 or 4 matrices of the same dimensionality. Each cell of the matrix represents the brightness of one pixel in one dimension of the color space. The greyscale space is one dimensional, from dark black to bright white. In an actual *color* space, for example the RGB cube, a

pixel would be composed of three numbers, each representing the brightness of the red, green and blue channel. Looking at the standard deviation of each pixel of 15 different bee images (selected by manually fitting a rotatable bounding box to a random individual from different recordings), the thorax and head region yields the lowest values and hence is the most stable region (see Figure 16).

Other visual features might be identified by observation. For example the first videos that I recorded were blurry while the dancer waggled. This could be such a visual feature, i.e. “the blurredness of an image region” whose recognition would require algorithms for identifying its numeric properties. This could be accomplished e.g. by checking for smooth image gradients along the waggle direction. There are many more features like the alternating bright and dark stripes on the abdomen that could be found in the frequency space using a Fourier Analysis or Wavelet Transform. A feature could be the shape of the bee extracted by an edge detector, its grey value appearance or even its decisive motion patterns.

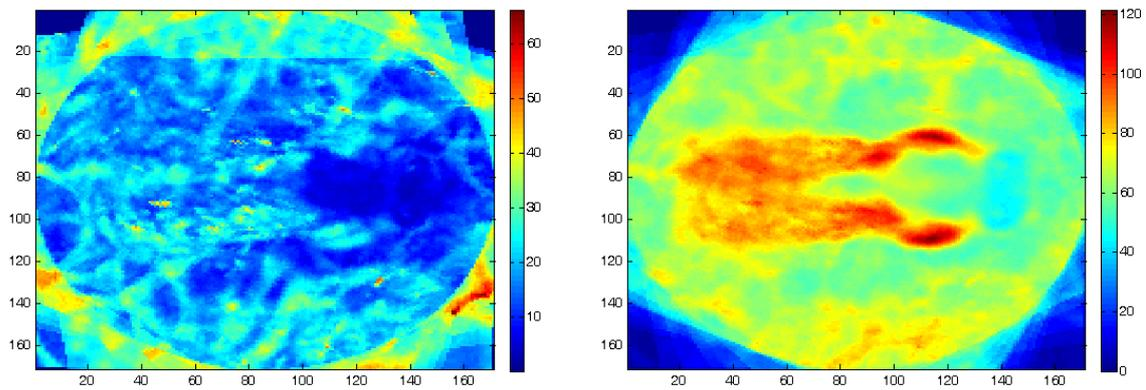
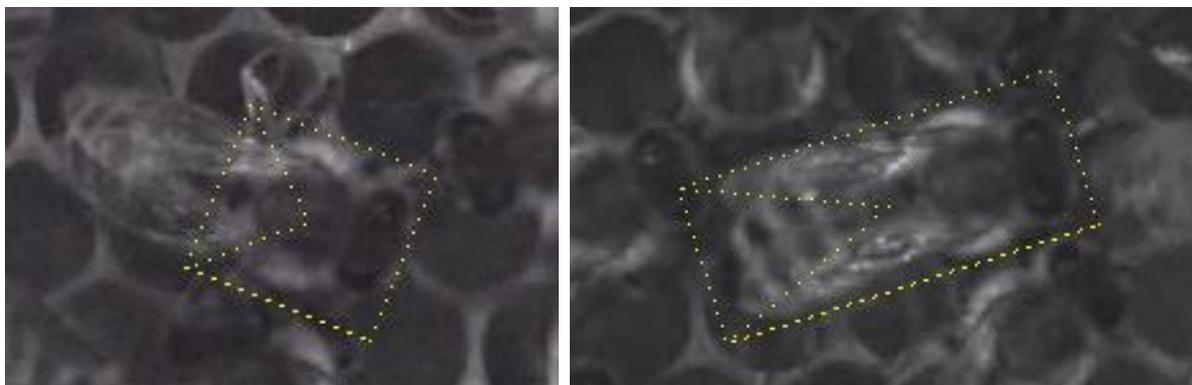

**Figure 16, left:** Standard deviation of 15 different bee images selected manually by a rotatable bounding box. All bee images were aligned according to the box’s rotation. Dark blue values indicate a low standard deviation; dark red values a high standard deviation. The lowest values are found in the thorax and head area. The abdomen shows medium variation. The red areas in the periphery can be discarded and originate from blank image regions that were introduced when the source region was close to the image borders.

**Right:** Mean image brightness of 15 different bee images selected by a rotatable bounding box. All bee images were aligned according to the box’s rotation. Dark blue values indicate dark image pixels; red values bright pixels. The darkest part of all bees is the head. The thorax exhibits bright hair at its sides. The abdominal part is also bright due to reflections. Since those are not constant the mean brightness is lower compared to the thorax hair.

### 3.3.3 DESCRIPTION OF PROPERTIES OF THE FOCAL ANIMAL AND RESPECTIVE STABLE FEATURES

In order to identify stable features for tracking honeybees a number of tests were conducted.



**Figure 17:** Selection of bees using a rotatable bounding box. The triangle points into the box’s null orientation. The selection of the thorax only might be favorable because of the high variability of the abdominal region.

#### TEST: TEMPLATE MATCHING

A straight-forward idea for finding subsequent positions of an object is correlating a template to hypothetical positions within the image. Assume the position is known for a particular frame. Since the recordings exhibit a high frame rate the bee's next location should be close. Given an initial position,  $P = (x, y, \alpha)$ , we expect the movement vector  $dP = (dx, dy, d\alpha)$  to be small. Depending on the zoom level of the camera, the maximum movement speed of honeybees and the recording frame rate this is in the range of only some pixels and degrees. If one would randomly distribute hypotheses around the known bee position and then correlate the underlying image with a previously defined template, one should be able to find the new position by selecting the hypothesis with the maximum correlation coefficient. The according algorithm was implemented. A bounding box was used to designate the position of the dancer bee. The template is extracted from the underlying video frame (initialization) and normalized to a zero degree orientation. Then, a number of hypotheses are generated by adding normal distributed noise to the three model parameters of the initial bounding box. Those scattered boxes are then scored by correlating the underlying image with the template. The best scored model is selected to represent the next position. Unfortunately this does not work satisfyingly. The preselected bee is lost, depending on the video quality, the amount of noise and the number of hypotheses, after 10 – 50 frames. The following reasons can be identified:

**1. Body flexibility, body roll motion**

First of all, honey bees are extremely flexible and versatile. One can observe rolling movements around the bee's longitudinal axis, showing parts of the sides. Then the abdomen of the animal can be retracted or extended. The three body parts (head, thorax, abdomen) can be moved and bent so that the appearance of the bee can differ extremely compared to the template image taken only a few frames before. The static bounding box is simply not able to capture the complex body configuration.

**2. Wing reflections and partial shadows**

Furthermore, the wings are very reflective resulting in a high variability of the pixels within the abdominal area. Figure 18 shows the same bee in different frames of one short video sequence. In that particular case the bee is marked. Tracking unmarked bees resulted in even less accurate tracking. Also, partial shadows, resulting from other bees or the spot-like lighting are identified to impair the correlation score.

**3. Motion blur**

A third, less severe reason of tracking failures is motion blur that may result from poor lighting conditions.

Improving the lighting conditions diminishes the influence of the problems 2 and 3 and improves the tracking performance significantly. A solution to problem 1 would include a model of the body flexibility.

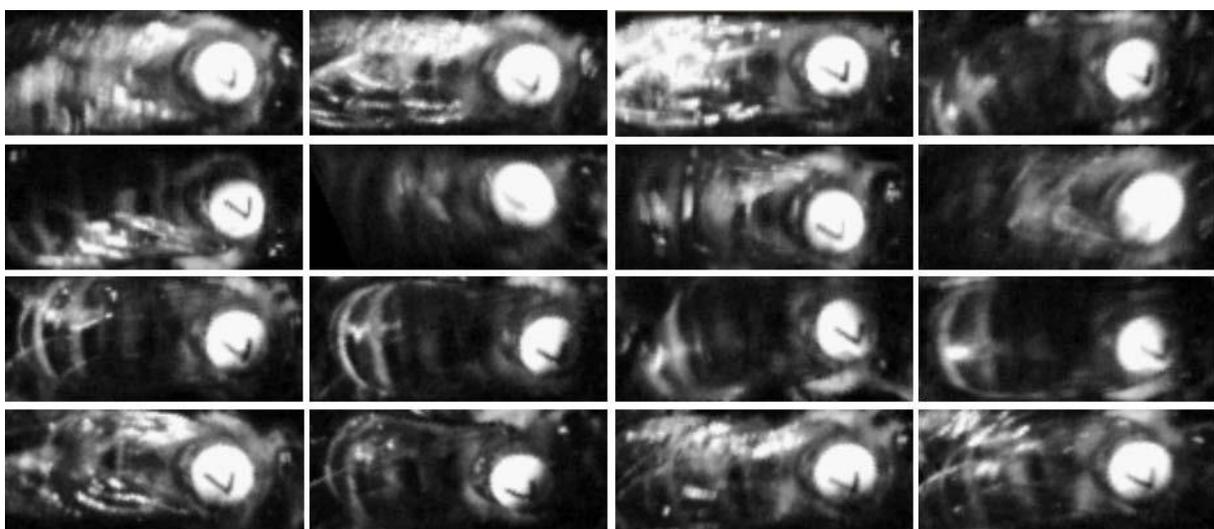

Figure 18: The image of the same bee was taken every 10th frame of a 5 second video clip while she was dancing. Due to lighting conditions, many reflections on the wings (first row) are observable. While wagging, a noticeable blur adds to the image variability.

Bees are also flexible and may be bending their abdomen (1st image of first row). Due to the spot-like lighting, other bees can cast shadows on to the dancer's body (two center rows).

Introducing an angle between abdomen and thorax would probably improve performance but increase search complexity. Modeling shape with ellipses (as in (Veeraraghavan, et al., 2008) ) would probably result in even better performance. Beside shape, a mutable model of the appearance, e.g. to account for the roll motion, would surely improve tracking results. However, computing 100 or 1000 correlations for one video frame, even using down sampled images, yields a very slow tracking performance of 0.2 frames per second (single core 2.66 GHz Pentium IV).

Apparently, the number of pixel comparisons has to be reduced to speed up the comparison process. An "intelligent" selection of a subset of the image has to be found. This could also improve the quality of the comparison by choosing only robust pixels or pixel patches that do not change much throughout the video and therefor can easily be found in a new frame.

### 3.3.4 SPARSE MOTION HOUGH TRANSFORM CLUSTERING (SMHTC)

Leaving a description of the detailed research path to the interested reader (Landgraf, et al., 2007), generally, those image features that "globally" define properties of bees (the shape, the appearance, etc) could not feasibly be extracted under all conditions and body configurations. While the silhouette of a bee might vanish due to frequent body contacts among the nestmates, the texture-rich body *surface* is visible most of the time. Wing reflections often exhibit a granular structure that does not change substantially between frames and therefor might even prove helpful for tracking the bee. Requiring a feature only to exhibit enough structure to be traceable over one or two frames, reduces the amount of information per feature (each feature might be found almost anywhere in the image). However, each focal animal might be described by more than one feature, rendering the identification more robust when a few features get lost. Additionally, computing the optical flow field of two consecutive images using those image features yields an approximation of the motion field at points that are "trustworthy" (by designing the feature detector appropriately). We assume that due to the parallelism of the camera plane and the hive plane the projection of the 3D scenario is warped only a little. Under these assumptions we might be able to identify the bee by only aggregating feature patches that show similar movements and lie in relative vicinity of each other. The identity of each feature is reduced to an anonymous point. This idea is the cornerstone of the following algorithm. The method, named Sparse Motion Hough Transform Clustering (SMHTC) consists of three basic steps.

- 1) identifying a number of pixel patches on the bee based on a particular quality measure (Interest Point Detection)
- 2) tracking each single pixel patch to the consecutive frame (Sparse Optical Flow)
- 3) evaluate the coherence of the motion of hypothetical point sets (Motion Coherence Evaluation)

#### INTEREST POINT DETECTION

While the computation of optical flow generally means to compute the flow vector of every pixel (or pixel patch) of the image and thus obtain a global flow field, sampled equally distributed, it is possible to do this computation only for an exclusive number of points. This results in a "sparse" optical flow field. The identification of such points is called interest point detection and a vast number of different feature detectors have been proposed (see (Tuytelaars, et al., 2008) for a survey). For choosing a certain detector a tradeoff has to be considered. On the one hand, the feature should be highly discriminative and robust under certain object transformations. On the other, the extraction should be fast. For the implemented algorithm a rather simple but fast method by Shi and Tomasi (1994) was used.

#### SPARSE OPTICAL FLOW

There is also a variety of algorithms available to track those point-like features. One group of methods would locate features in both frames, i.e. the current and the next, and compare them based on a pixel neighborhood or some function or model of it. Another approach is starting with the old position obtained from the last

frame as a seed and then apply a local search to localize them. Again, a fast algorithm is favorable and the latter methods restrict the search space. Standard data structures like image pyramids or methods like gradient descent are superior in speed to an exhaustive search. In SMHTC, the algorithm proposed by Lucas and Kanade (1981) is used to track a number of point-like features over a preset amount of frames. Due to the projection of a three-dimensional scene onto the two-dimensional image plane there are complex transformations that object features might undergo. The optical flow matching task is inherently an ill-posed problem. The features will eventually lose quality, expressed in the similarity of the pixel patch compared to a reference patch (e.g. in the initialization frame). These features must be sorted out and replaced. Using an initial set of features found by the detector described by Shi and Tomasi (1994) and tracking them using the algorithm of Lucas and Kanade (1981) typically results in the rejection of a large portion of the features after 15-25 frames. Although there are features that lose track and move off the bee the general impression remains positive. By watching the movements of these point tracks without displaying the originating video it is easy for a human observer to recognize the shape and movements of the bees. The optical flow reduces the amount of information to the essential parts. Only some pixel patches are traceable at all. All others are neglected. A second level of information is created on which the signal to noise ratio is increased. Therefore the tracking based on sparse optical flow fields is more robust than the template correlation tracker. The tracking that I propose here is based on this second layer. The drift of quality of the optical flow features or even the complete loss of track makes refreshing of the features necessary. For a feature that has been found on the corner of a reflection on the wing the probability of losing it will be high after only a small number of frames. Due to the flexibility and agility of the bees even features that are located on stable corners (e.g. on the thorax) will lose track eventually. Simplifying this observation, the quality of an arbitrary optical flow feature decreases with time independently of the nature of the feature. It might be a robust notion to re-initialize all optical flow features after a constant amount of time. Re-initializing the whole set of features after a number of frames poses a problem: Motion information between frames  $i$  and  $i+1$  where  $i+1$  is the index of re-initialization would be lost (see Figure 19). I propose to overcome this problem by re-initializing only a portion of the feature set while the rest is still being tracked to the following frame. Equivalently, it is imaginable to track more than one set with shifted re-initialization times. Because these sets overlap I call this idea "overlapping optical flow". Suppose we have  $s_n$  sets of optical flow features. Each one of the sets is constructed to contain a number of features for the whole image (or a predefined region of interest, ROI). Let  $i$  be the current frame index of a video sequence. Then let the (re-) initialization be performed for set  $s = i \bmod s_n$  on the  $i$ -th image (see Figure 20). All features contained in all other sets are tracked using the Lucas-Kanade tracker. For  $s_n = 3$ , each set is re-initialized after 3 video frames, thus we obtain point tracks of two sets (the 3rd set is re-initialized). The information obtained from the tracking of the feature points contained in these sets is highly redundant and could be subject to optimization (e.g. erase very close points). But since the number of feature points is high it seems to be possible to extract shape information from these point tracks as well.

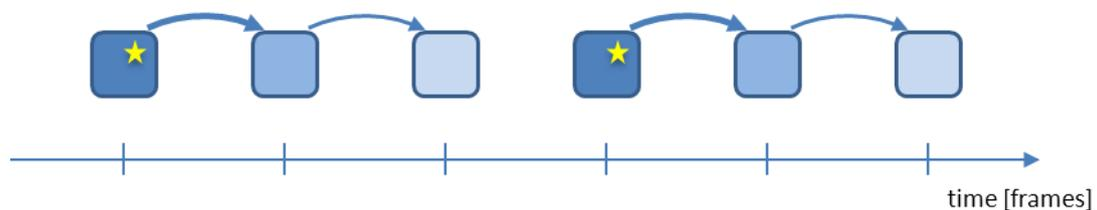

**Figure 19: Optical flow tracks.** One box denotes a set of optical flow features. Tracking the features decreases feature quality (denoted by the lighter color of the boxes). Initializing the whole feature set (in frame 3) yields the loss of motion information. Re-initializing in frame 2 would either overwrite the old feature positions or require additional memory.

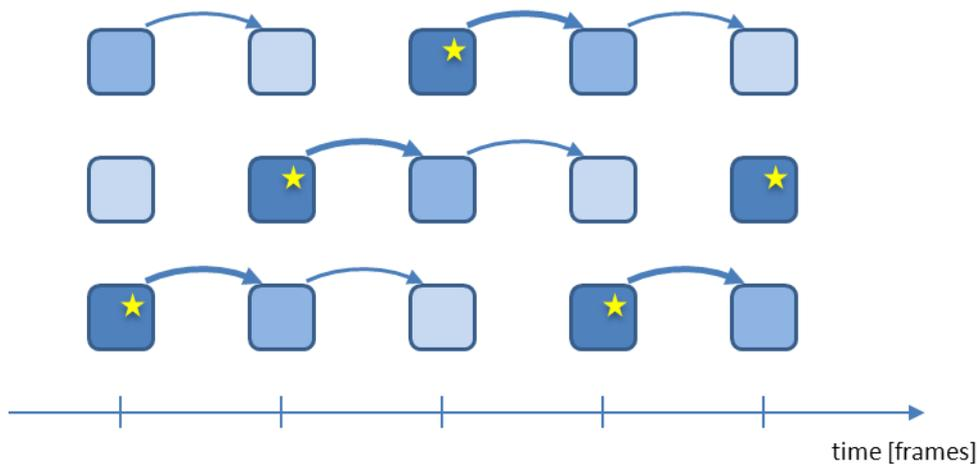

Figure 20: Overlapping optical flow. Each row stands for an exclusive set of optical flow features. The algorithm initializes a set every frame. Each set is (re-) initialized every 3rd frame. The asterisk denotes an initialization step for the particular frame. After re-initialization, with every next time step, we lose confidence that the features still represent the body parts that were associated to the image features used in the initial frame. For each time, two sets of optical flow tracks are available for further evaluation.

### MOTION COHERENCE EVALUATION AND SHAPE EXTRACTION

How can one extract shape and motion from these point tracks? Since the initial position of the bee to be tracked is given manually by the user, it is already known which point features lie on the bee. But after a number of frames these points are replaced by a new set of points. How can one cluster a subset of points such that they are likely to represent the shape (or at least position and orientation) of the bee?

The simplest model of the shape of the bee is a rectangular rotatable bounding box. The most important shape features of the bee (i.e. length, width, orientation and position) are embodied in this model and computations such as the selection of points lying inside or outside a bounding box is possible using fast integer arithmetic (unlike e.g. using ellipses). If such a box is used to select an area of the image that by and large is occupied by the bee all feature points can be selected easily. This selected subset of points (or after applying the optical flow tracker: point tracks) can be used to compute the transform of the bee. Since we now have a rather safe set of points (we are at least for the very first frame confident that almost all points in the box belong to the bee) we can access the transform directly. Assuming only small amounts of non-rigid point movements it is possible to compute the rigid transformation  $T = \{A, t\}$  that transforms the point set  $P^{(k)}$  into  $P^{(k+1)}$  as  $A \cdot p_i + t = p_i$  (for all  $p_i$  in  $P^{(k)}$  and  $P^{(k+1)}$ ) using the pseudo-inverse (least-square solution after Penrose, 1955). Applying  $T$  to the bounding box we move it according to the bee's motion and, if the error in all stages of the computation is considerably low, the box is still marking the bee body in the new frame. For artificial test data this gives the expected results. This method, however, is known to be sensitive to outliers. It fails to compute the right rigid transform on real optical flow data. Using more robust methods (e.g. RANSAC (Fischler, et al., 1981) ) it is possible to account for the noisy data and extract more accurate transformation parameters.

But still there might be errors in that computation (errors that come from the Lucas-Kanade tracker and errors coming from the assumption of a rigid transformation) and the generated shift of the bounding box leads sooner or later to the selection of slightly wrong points (some points on the bee are missing in the selection and some selected points are outside the bee area) and the following computation is less accurate - resulting in an accumulation of errors. It is therefore desirable to define a measure of how well the box fits the point tracks of the underlying optical flow dataset. If the bounding box is fully congruent with the point features that correspond to the bee, then the number of points that move consistently (according to a specific model) is maximal. I therefore propose using a measure of how coherently a point-subset is moving to correct for the accumulated error.

Let's imagine the bounding box has been shifted according to the extracted parameters of the suspected rigid transform. After a number of frames there will be a slightly wrong orientation or position of the bounding box.

Selection of the optical flow features inside the box to extract the next movement parameters would lead to wrong results that would accumulate “catastrophically”. If we randomly distribute a small number of bounding boxes (pose hypotheses) around the found position we would most likely hit the real position of the bee. The way of scoring this particular box better than all the others by evaluating only the optical flow data is described next. The following section shows a maximum likelihood method that combines all requirements, i.e. the extraction of the motion parameters and the evaluation of the fit to the bee, into one algorithm.

A well-known method in computer vision, the Hough transform (Hough, 1962), robustly finds the parameters of a given model. Usually the task is to find the occurrence of geometrical shapes such as lines, circles, ellipses, etc. in the edge image of a scene. It is however, possible to use it to extract the three parameters of a rigid transform even under noisy conditions.

Let  $Q = \{p_1^z, p_1^{z+1}, \dots, p_1^{z+m-1}; \dots; p_n^z, p_n^{z+1}, \dots, p_n^{z+m-1}\}$  be the global set of  $n$  point tracks of length  $m$  beginning at time  $z$ . Let  $B = \{w, h, x, y, \phi\}$  be an arbitrary bounding box of width  $w$ , height  $h$ , position  $(x, y)$  and orientation  $\phi$ . Let then be  $Q(B) = \{p'_1{}^z, p'_1{}^{z+1}, \dots, p'_1{}^{z+m-1}; \dots; p'_k{}^z, p'_k{}^{z+1}, \dots, p'_k{}^{z+m-1}\}$  the subset of  $Q$  with  $k$  point tracks where the condition “ $p'_i{}^t$  lies in  $B$ ” is met for all  $i = 1..k$ . Suppose  $Q(B)$  holds the motion field of an object that is moved rigidly between times  $z$  and  $z+m-1$ . We first like to find the rigid transformation  $T = \{A, t\}$  that explains best the movement of all  $p'_i{}^z$  to  $p'_i{}^{z+1}$  where  $A$  is the rotation matrix,  $t$  is the translation vector. Given a rotation angle  $\alpha$  the matrix  $A = (\cos\alpha \ \sin\alpha; -\sin\alpha \ \cos\alpha)$ . Since the points of one point track are known before and after the transformation one can directly compute the translation vector  $t = (t_x, t_y)$  given  $A : (t_x, t_y) = p'_i{}^{z+1} - A \cdot p'_i{}^z$ . Following the idea of Hough we compute all translations for all possible (feasible) rotations and increment a counter for a group of transformation parameter triples. Suppose a rotation matrix  $A$  is given for an arbitrary angle  $\alpha$  and  $t_x$  and  $t_y$  are calculated as given above. The movement of one single optical flow feature results in a ‘vote’ for the triple  $(\alpha, t_x, t_y)$ . By creating a 3D matrix  $M$  of integers (called accumulator) we are able to count the votes for all rotations of all point moves by indexing  $M$  with rounded values of  $\alpha, t_x$  and  $t_y$ . The result is an approximation of the density function that describes the probability of the (rigid transform) parameters given the point movements. Finding the index of the maximum of  $M$  yields the most probable transform triple  $T_{\max} = (\alpha_{\max}, t_{x \max}, t_{y \max})$ .  $s = \max(M)$ , the maximum itself (the number of votes for  $T_{\max}$ ), reflects how many point movements ‘overlap’ into the same accumulator cell. Given an overall number of  $k$  points that were selected using the bounding box the quotient  $q = s/k$  would yield the relative portion of coherently moving points. Since  $q$  is a function of the bounding box  $B$  (as well as the subset  $Q(B)$ ) we can maximize  $q(B_i)$  for a set of bounding boxes  $B_i$  ( $i=1..n_b$ ). The maximally scored bounding box contains the most consistent point movements and is therefore likely to contain the bee. The Hough transform provides the means of extracting the transformation parameters as well as measuring the coherence of motion. An efficient implementation and a description of its validation are given in (Landgraf, et al., 2007).

### 3.4 ANALYSIS OF BEE DANCE TRAJECTORIES

The aim of the following analysis on the one hand is to learn about framing properties of the honeybee robot to be built. This includes global parameters as velocity limits or the size of the area a dance takes place in. On the other hand this analysis should yield a feasible model of the honeybee dance. This analysis is supposed to grasp the importance of certain motion features over others. Which information (i.e. motion pattern) should be reproduced by the model? Which parameter might carry information and thus should be integrated into the model?

The trajectories obtained with the tracking program are the most detailed and precise motion information of the bee dance available to the research community. With this data at hand one is able to extract much more information than possible previously. Even in recent publications on the honeybee dance precision researchers describe the data extraction as a highly manual work using plastic sheets as screen overlays and protractors. Accordingly this kind of analysis is restricted to only a few parameters (e.g. the waggle angle or the waggle run length). The tracking process extracts an intermediate layer of information that then can be queried for different parameters. Some of the following results and figures have been published in (Landgraf, et al., 2011).

The motions we observe might be a mixture of an “ideal” dance motion and other motions that are superimposed or interspersed depending on external and internal stimuli. Examples of those include evasive maneuvers, stops for trophallaxis and re-initiating the dance after unloading the crop. By analyzing many dance trajectories I expect that the influence of non-dance behaviors cancels out statistically. To assess a minimum number of parameters that can be used to model a realistic dance I listed numerous candidate properties of the trajectory data. After computing a variance analysis, those parameters that show high variability are discarded. A high variation might indicate a high error. Low-variance parameters might be “conserved” and are likely to convey meaning since they transmit the lowest amount of uncertainty. However, some error might be ecologically beneficial (see “Tuned Error Hypothesis”, (Towne, et al., 1988) ).

Some remaining parameters are redundant, e.g. might one measure the body orientation in the waggle run as well as the angle of the path that the dancer describes in the waggle run. Both measures try to capture one aspect of the sender’s message. It is unclear which aspect or parameter is informative to the receiver. However, in this analysis, the parameter with lower variance is selected for the dance model which is presented in the last part of this section.

The trajectory data allows a vast variety of statistical queries. Here, I divide the parameters in different classes "Global Dance Parameters", "Waggle Parameters", "Return Parameters" and "Intra-Waggle Parameters"<sup>3</sup>. Section 3.4.3 enumerates the most important properties extracted and classifies them into the aforementioned categories.

### **3.4.1 TRACKING THE VIDEOS, RESULTING TRAJECTORIES AND PREPROCESSING**

Video recordings of dances advertising the same (230 m distant) feeder were used for the present analysis. The videos were then subjected to the tracking program. The program computed an automatic position that was checked by a person and corrected manually if necessary to produce reliable data. For every video frame, the software stored the orientation and planar position of a bounding box to a file. Because our video recordings have different magnification levels we measured the number of pixels of a unit distance (5 mm, a comb cell diameter) using a custom program. The trajectories were then translated to millimeter scale and rotated by the sun's azimuth angle and the feeder's direction in the field. After that rotation all dances were normalized, i.e. all waggle runs should “point” to 0°. Thus, all angular measures of dances of different day times were made comparable. The total number of waggle runs entering the analysis is 1009. They were obtained from 108 dances of 20 individuals.

### **3.4.2 AUTOMATIC WAGGLE SEGMENTATION**

The waggle portions are the trajectory segments believed to contain direction and distance information. The waggle frequency is known to be around 13 Hz to 15 Hz. The waggle runs can be detected automatically using the following method:

1. Compute the derivatives of x-, y- and orientation-coordinates.
2. Calculate the Fourier-Transform of a linear combination of the three derivatives.
3. Set the Fourier coefficients 0 that refer to frequencies < 11 Hz and > 17 Hz (equivalent to defining a band pass filter).
4. Use an inverse Fourier-Transform to obtain the band pass filtered composite motion function.
5. Binarize this function according to a dynamic threshold (a function of mean and standard deviation of the signal).
6. Fill small gaps (using dilation and erosion operations)
7. Delete small sequences (erosion and dilation)

The Fourier transform, which decomposes a signal into its constituent frequencies, is applied using a sliding window of 0.2 seconds width. If spectral activity of the body motion is found between 11 Hz and 17 Hz (i.e. the

---

<sup>3</sup> Thanks to Rodrigo De Marco for proposing this hierarchical class separation.

bandpass filtered signal exceeds a threshold defined by the mean plus one standard deviation) the respective window is selected to contain tail-wagging. The resulting binary data is post-processed using dilation and erosion operations, known from image processing, to close gaps in some waggle runs and erase short sequences. Then the start and end indices of the waggle sequences were collected, stored to a file and manually reviewed. Some waggle runs were too short to be found by the automatic procedure since they consist of just one oscillation. Those were discarded. We consider only waggle runs longer than two oscillations in the manual review or 100 ms in the automatic one.

### 3.4.3 PARAMETER CLASSES

The measured parameters of the trajectory had been clustered hierarchically. Figure 21 depicts a natural dance period (two consecutive waggle runs with return runs) and contains a visualization of most of the parameters extracted in the analysis.

#### GLOBAL DANCE PROPERTIES

This section encloses parameters specific to a dance period, i.e. the sequence waggle-return-waggle-return (see Figure 21). These are

- *dance duration*: the duration of a period in seconds
- *dance area*: the spatial distribution of a dance period in millimeters
- *dance orientation*: the average angle of the dancer throughout a dance period
- *waggle-return duration ratio*: the ratio of consecutive waggle and return durations

#### WAGGLE RUN RELATED PARAMETERS

The waggle run class is specific to parameters describing a waggle run or relations between waggle runs. These are:

- *waggle duration*: the duration of a waggle run in seconds
- *waggle length*: the length of a line connecting start and end point of a waggle run in millimeters
- *waggle orientation*: the average of all stored body angles throughout the waggle run in degrees
- *waggle direction*: the angle of a linear least-squares fit of the smoothed waggle run's planar positions in degrees
- *waggle drift*: the displacement vector of two consecutive waggle runs
- *waggle divergence (method A)*: the angle between the average orientation (or direction) of all left and all right waggle runs
- *waggle divergence (method B)*: the average angle between consecutive waggles

#### RETURN RUN RELATED PARAMETERS

In this section parameters describing return run properties are clustered:

- *return run duration*: the average duration of a return run in seconds
- *return run forward velocity*: coefficients of a polynomial fit of the mean forward motion (average of all return runs, a function over time)
- *return run sideward velocity*: coefficients of a polynomial fit of the mean sideward velocity (ditto)
- *return run angular velocity*: coefficients of a polynomial fit of the mean turning velocity (ditto)

#### INTRA-WAGGLE RUN PARAMETERS

All parameters that describe intrinsic properties of waggle runs are specified in this class:

- *The orientation amplitude*: the difference of the dancer's body orientation in consecutive turning points of a waggle oscillation

- *displacement amplitude*: the distance of a turning point to the midpoint of the previous and following turning point
- *waggle frequency*: number of waggle oscillations per unit time with a period being one left and one right deflection
- *waggle velocity*: the average forward velocity in the waggle phase
- *waggle steps*: the displacement vector of all left and right turning points

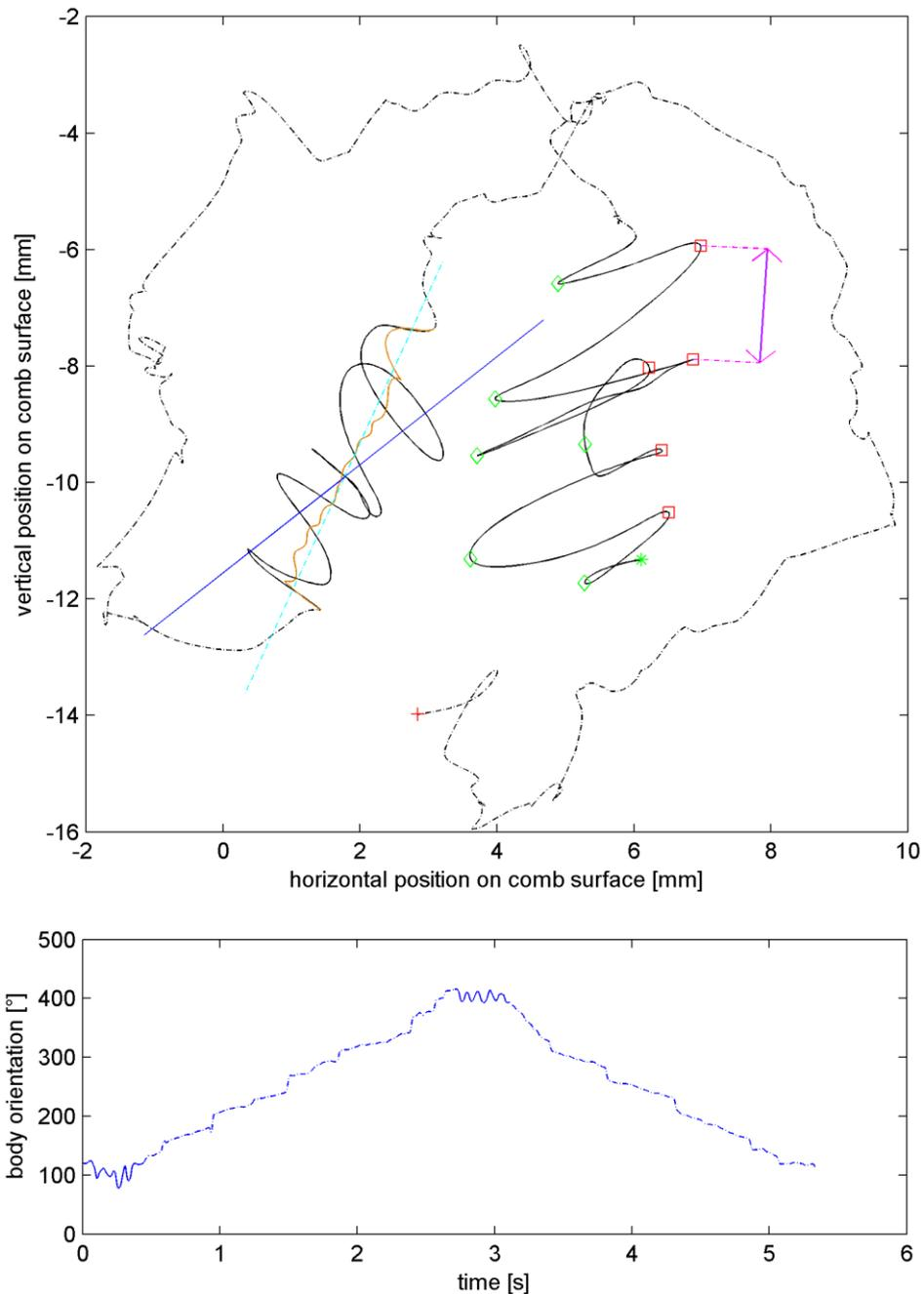

Figure 21: Top: Plot of planar positions of the dancer bee's center. Two consecutive waggle runs are depicted. Return runs are dash-dotted. Start and end are marked with an asterisk and plus sign, respectively. On the left waggle run we show the linear least squares fit (dashed line) of the smoothed waggle (light grey solid curve) and the mean orientation line (solid line). In the right waggle run we marked the left and right turning points of the waggle oscillation with a diamond and square sign, respectively. Bottom: Orientation of the bounding box over time. Return run orientation is dash-dotted.

### 3.4.4 GENERAL PROCEDURE AND STATISTICAL METHODS

A number of parameters are already known to be highly correlated to particular properties of the feeding location.

E.g. the angles *waggle orientation* and *waggle direction* correlate with the direction to the feeder. The *waggle length* or the *waggle duration*, the *return length* and *return duration* or even the number of waggle oscillations per waggle run correlate with the distance to the feeder (Frisch, 1965). Our analysis also gives a numerical reason for the choice of one of these redundant parameters over the other: we assume that a lower variance indicates the conservation of that property and thus a high significance in the decoding process.

After the parameter selection the model is supposed to create a dance that meets the frame properties that are described by the global parameters - these are not included explicitly in the model. They form the spatial and temporal limits of the robotic dance and serve only to verify the model.

Besides the properties described in the literature, we characterize the *waggle drift*, i.e. the vector connecting two consecutive waggle run's starting points. To decide whether to include the property into the list of dance parameters we test the hypothesis of different means with a Hotelling T-square test. I introduce the parameter *waggle step* as the vector connecting two consecutive left or right turning points of waggle oscillations. This might be of interest, because the turning points are likely to be the antennal "sampling points" of the waggle motion from the perspective of the dance followers. Also, I introduce two measures for describing the amplitude of the waggle motion: *orientation amplitude* and *displacement amplitude*. The former is defined as the orientation difference at two consecutive turning points; the latter is defined as the distance of a turning point to the midpoint of the line that connects the one before and after.

The program MATLAB is used for the statistical analysis. With the help of many students<sup>4</sup>, all automatically obtained results were reviewed manually. First, a script that identifies the waggle phases is run to obtain the separation needed for the class-specific analysis. The x,y positions were smoothed before fitting a line for the parameter *waggle direction*. This was necessary for very short waggle phases because these were "shorter than wide", i.e. the fit would express the lateral motion rather than the forward motion. Smoothing the trajectory helps to extract the direction of the waggle, but might be a source of additional error. Some authors have used one or the other method to measure the waggle angle (Weidenmueller, et al., 1999) (Sherman, et al., 2002), (De Marco, et al., 2008), (Frisch, 1965), (Seeley, 1995). Interestingly, in some dances these angles differ significantly. Some bees "look" into a direction different to the direction of their waggle path. Another script identifies the turning points of the waggle runs by finding the points on the trajectory that locally maximize the orthogonal distance to the mean direction line, as depicted in Figure 21.

Some return runs are interrupted, i.e. the subsequent waggle run is performed after a long time, after trophallaxis or other behaviors. These runs are not considered a return run and the waggle run that follows is not paired with the one before for the computation of the waggle divergence. The threshold for exclusion is 4 seconds (*return run duration* plus two standard deviations is around 3 seconds).

To compare the variability of parameters of different scales and units we compute the coefficient of variation (CoV) which is defined as the standard deviation divided by the mean. The two-dimensional test of difference of mean is performed using Hotelling's T-square statistic. Difference of means of one-dimensional data is done with a Student's t-test. Test for uniformity of circular data is performed with Rao's spacing test.

### 3.4.5 RESULTS

#### GLOBAL PARAMETERS

The CoV of the *dance period duration* is 0.16. That is a hint to a very tight temporal dance regime. The standard deviation of the *dance area* is around 7 mm<sup>2</sup>. That means almost all dance periods are performed within an

---

<sup>4</sup> To whom I am most thankful: Katja Stettin, Hai Nguyen, Fabian Kriegel

area of  $28 \text{ mm}^2$ , i.e. a square with edges two bee lengths long. The distribution of the dance angle is uniform ( $P = 0.5$ ). That renders it likely that follower bees differentiate between the body pose of the dancer in waggle - and return runs. The CoV of the waggle-return-ratio is 0.44. Again, this points to the high importance of stringent temporal dynamics.

### WAGGLE RUN PARAMETERS

The *waggle run duration* has low variance (CoV = 0.36). The means of the two angular measures waggle direction and waggle orientation are not significantly different (two tailed t-test,  $P = 0.3078$ ). The mean drift vector was tested to be not significantly different to a zero drift (Hotelling T-square, F-Test,  $P = 0.178$ ) meaning that dancing bees are not systematically progressing in a certain direction from waggle to waggle. The analysis of the waggle divergence reveals a difference in the orientation and direction measure. Showing similar variance, the difference of both divergence measures is extremely significant ( $P < 0.0001$ ). The actual waggle path a dancer describes therefore gives a better approximation of the “real” direction to the feeder than the body orientation.

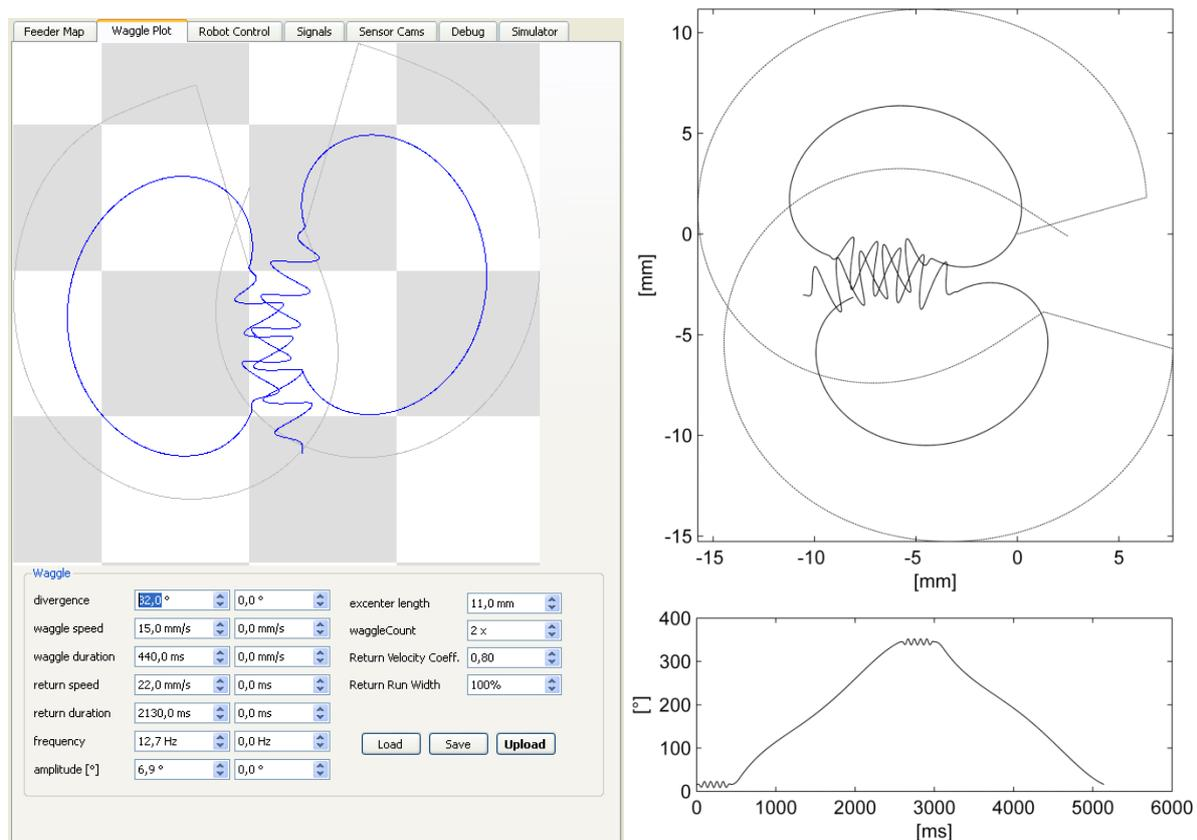

Figure 22: The dance model consists of those parameters that were identified in the variance analysis. For the configuration of the robot, the model can be evaluated to show the resulting trajectory. The graphical user interface (the left image shows a screenshot) allows to alter the parameters and therewith the shape of the dance.

### RETURN RUN PARAMETERS

The parameters *return duration* and *return velocity* have a coefficient of variation of 0.22 and 0.21, respectively. We resampled forward, sideward and angular velocities in each return run to vectors of the same dimensionality (700 elements), which corresponds to one third of the mean duration. Afterwards, the vectors were averaged and the mean function was fitted using a polynomial model (Figure 23). Both the forward and the sideward motion (for both left and right return phases) show interesting characteristics in the course of the return. A dancer turns the fastest just shortly after the waggle and slowest just before the following one. The amount of sideward motion is not negligible and always directed outwards (for convenience shown as negative velocities in Figure 23).

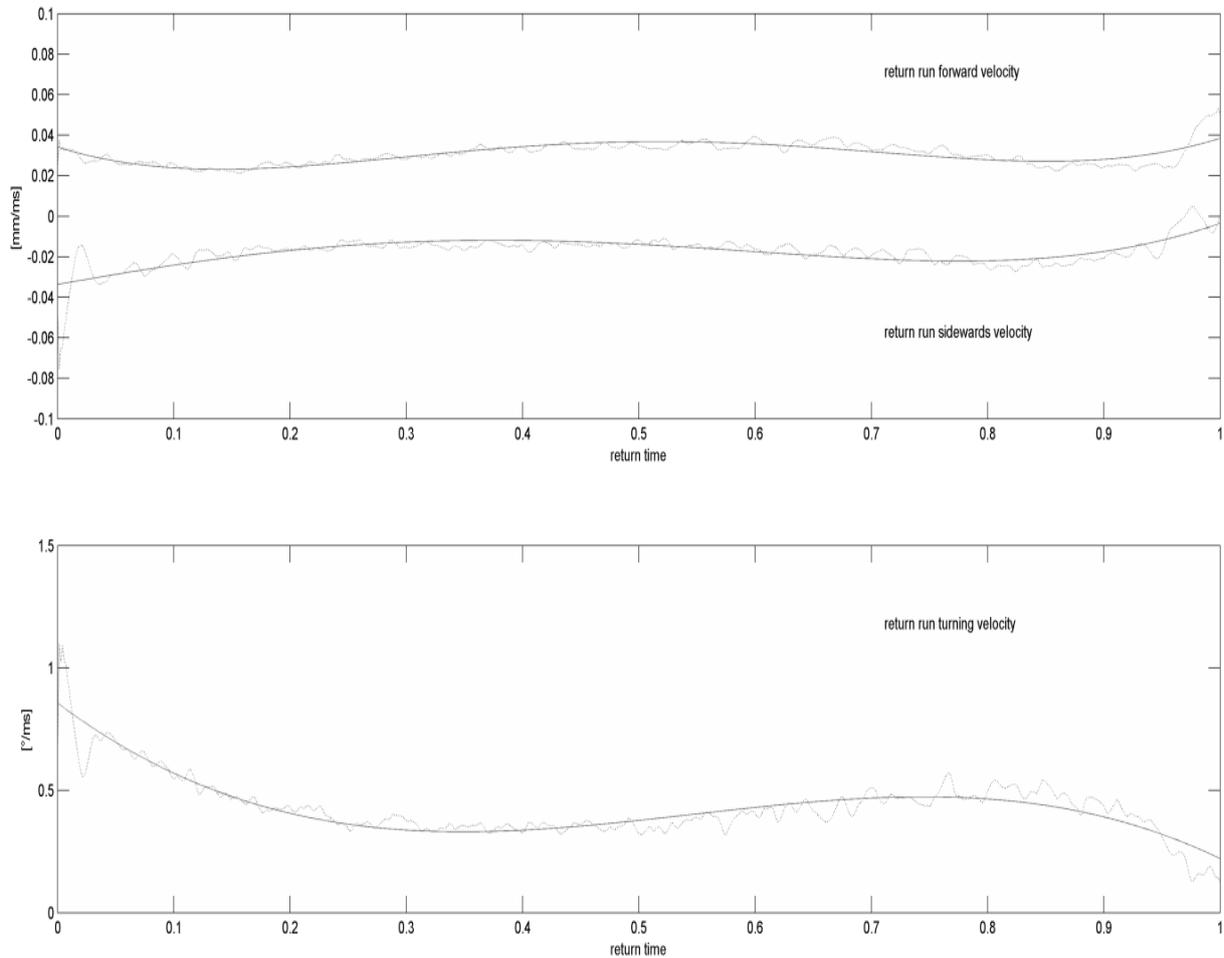

Figure 23: All return runs were subsampled to an equal number of samples and averaged. This average was then used to find a polynomial fit. The figure above shows three velocities: the forward, sideward and turning velocity. Each curve is parameterized by four values  $a_0$ - $a_3$ , for a polynomial of the general form:  $f(x) = a_0 + a_1*x + a_2*x^2 + a_3*x^3$

### INTRA-WAGGLE RUN PARAMETERS

The *orientation amplitude* is found to be more variable than the *displacement amplitude*. Coefficients of variation are 0.6 and 0.38, respectively. The *waggle frequency* band is rather narrow (CoV = 0.15). Since dances of 20 different dancers were pooled, one might expect the individual variance to be even lower. The speed of forward motion in the waggle phase also has low variance (CoV = 0.33). The *waggle steps* clearly point forward. A closer look at the distribution (Figure 24) reveals two modes: One peak at (0 mm, 0 mm), i.e. a lateral waggle motion that contains no forward movement and one peak at (1 mm, 0 mm) that corresponds to the forward motion of the dancer after one single waggle oscillation. This sharp peak corresponds to one step a dancer executes in the waggle phase. Interestingly, the distribution has almost unit variance in both dimensions, i.e. the system shows comparable variability for the lateral wagging motion as for the forward motion.

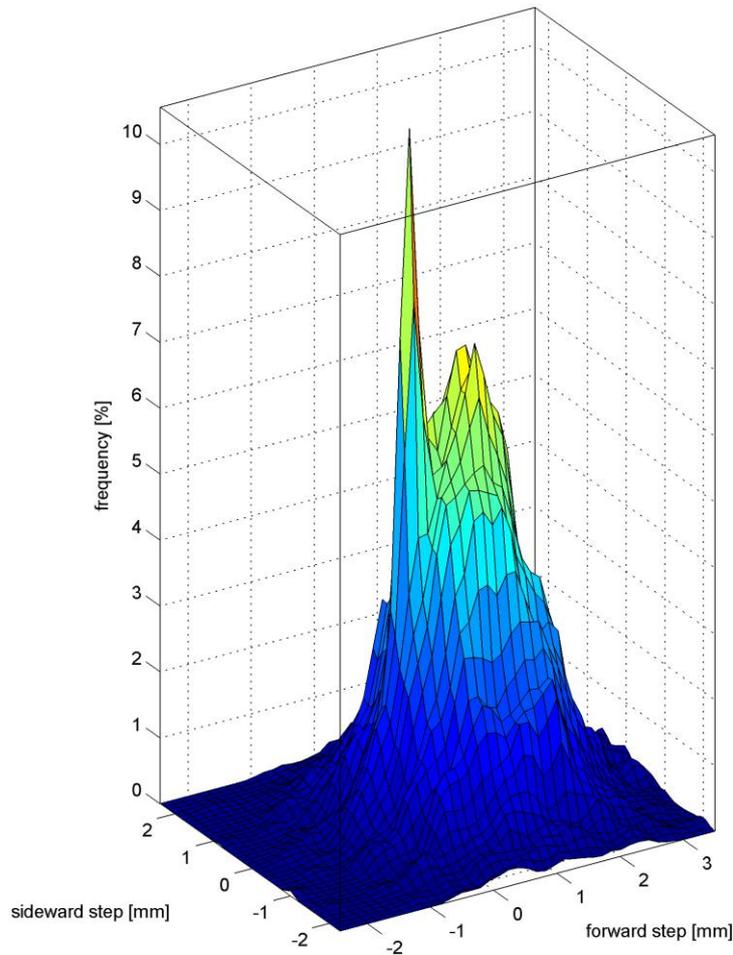

Figure 24: The histogram of the waggle step vectors exhibits two modes: a sharp peak at (0 mm, 0 mm) and another local maximum at 1 mm in the waggle direction. The former corresponds to wagging on the spot; the latter reflects the forward motion through one waggle movement.

### 3.4.6 THE ROBOTIC DANCE MODEL

We include the following parameters in the dance model: *waggle duration*, *waggle forward velocity*, *waggle orientation*, *divergence*, *return forward velocity function*, *return sideward velocity function*, *return angular velocity function*, *displacement amplitude* and *waggle frequency*. Using these parameters a dance model was developed and tested on the robot. Since a waggle motion contains oscillations of around 13 Hz in all three dimensions (planar position and orientation) the robotic motion generated a lot of unwanted vibrations. To reduce the amount of mechanical noise we now only use the orientation motor for the waggle oscillation. The robot's body is eccentrically fixed on the robot's arm such that the rotation axis of the robot points 1 cm in front of the robot body's head. Using this trick we can generate x,y-oscillations using only one motor. To reduce mechanical noise in the transition from return to waggle phase the waggle oscillation is multiplied with a linear ramp. Figure 22 shows a trajectory produced by the final model, which can be found as Matlab code in the appendix of (Landgraf, et al., 2011).

Parameter	Unit/Ann.	$\mu$	$\sigma$	$\frac{\sigma}{\mu}$
<b>Global Parameters</b>				
dance duration	s	5.24	0.85	0.16
dance radius	mm	-		
	x	-	7.6	-
	y	-	7.1	-
waggle-return	-	0.22	0.10	0.44
<b>duration ratio</b>				
<b>Waggle Parameters</b>				
duration	s	0.44	0.16	0.36
waggle length	mm	6.32	2.36	0.37
waggle orientation	°	-0.03	28.06	-
waggle direction	°	1.24	24.85	-
waggle drift	mm			
	forward	0.27	4.57	-
	sideward	-0.01	4.62	-
divergence A	°			
	orientation	31.98	-	-
	direction	22.11	-	-
divergence B	°			
	orientation	33.12	19	0.57
	direction	22.76	29.86	1.31
<b>Return Parameters</b>				
return duration	s	2.13	0.47	0.22
return velocity	mm s <sup>-1</sup>	20.10	4.27	0.21
<b>Intra-Waggle Parameters</b>				
orientation	°	13.89	8.33	0.60
<b>amplitude</b>				
displacement	mm	2.64	1	0.38
<b>amplitude</b>				
waggle frequency	Hz	12.67	1.89	0.15
waggle velocity	mm s <sup>-1</sup>	15.04	5.00	0.33
waggle steps	mm			
	forward	1	0.9	-
	sideward	0.04	0.9	-

**Table 3: Statistics of dance properties. Units and annotations are shown in column 2. Means, standard deviation and coefficient of variation are given, if available.**

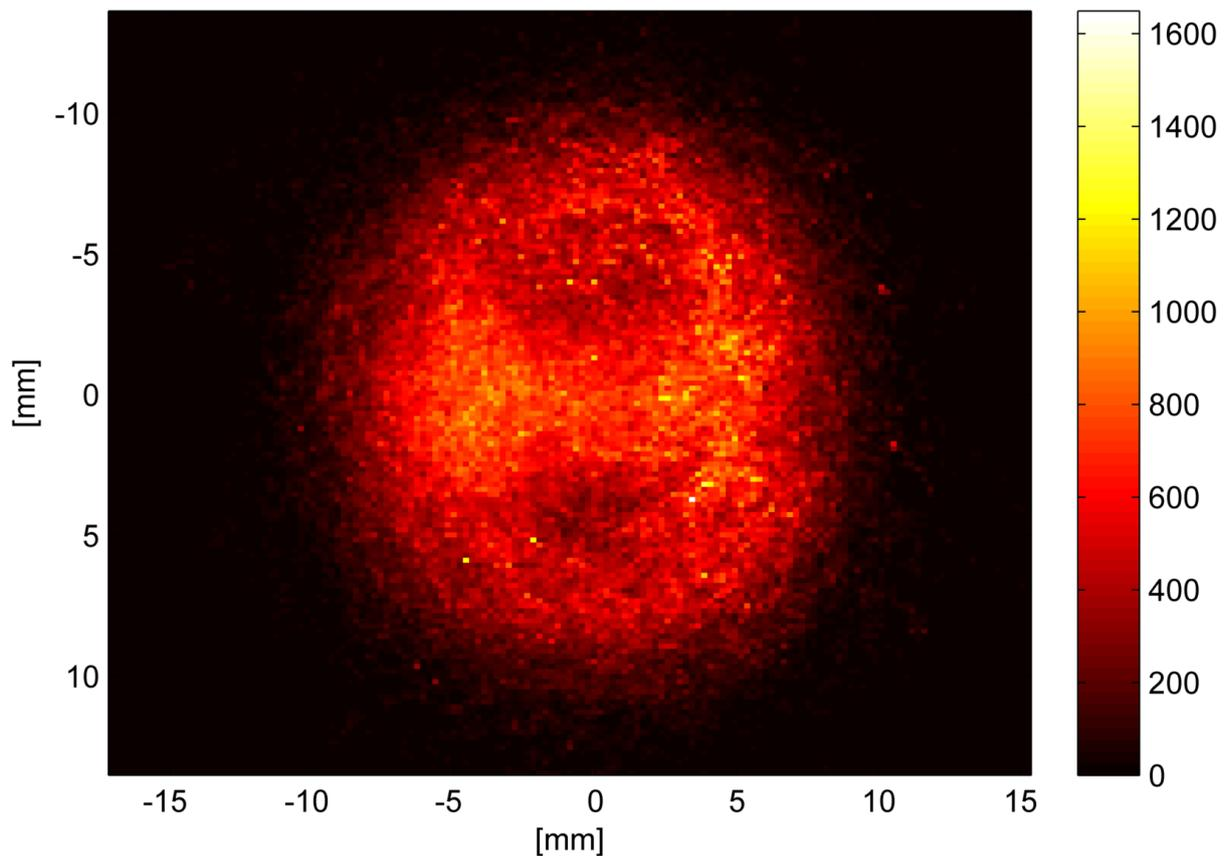

Figure 25: 2D-Histogram of the body positions of dancing bees throughout 742 waggle periods (waggle-return-waggle-return). Dark regions denote a low frequency of presence. The trajectories were centered period-wise, i.e. I subtracted the mean from each of the W-R-W-R-paths.

### 3.4.7 DISCUSSION

I propose a waggle dance model which produces trajectories closely resembling real ones. In this study I limited the analysis to obtain the parameters for the description of honeybee waggle dances advertising a fixed distance of 230 m. Future work will include recording, tracking and analyzing dances for a discrete set of distances.

The proposed low variance parameters indicate the significance of particular body pose or motion properties in the communication process. The way how the dancer's body moves and how this motion modulates other dance-related stimuli can, however, plausibly be allocated to and modeled with these particular properties. Furthermore, the evaluation allows some interesting inferences.

The mean angle of all positions throughout the dance (the dance angle) is uniformly distributed. No meaningful direction information can be obtained by sampling the body pose of the dancer throughout the whole dance. The waggle run, as the medium for the polar coordinates, needs to be highlighted in some way. It remains unknown if the waggle motion or other signals only present in the waggle phase, such as signals arising from wing oscillations, implement this.

Both angular measures of the waggle exhibit a high variance. Averaging over all angles, however, yields a very good approximation of the direction to the feeder. The integration of subsequent samples of the waggle angle thus improves the precision of the message. De Marco et al. (2008) carried out a random resampling analysis to assess the error of the dance message as a function of the number of waggle runs followed. Although random sampling might not be a realistic simulation, it underlines the great amount of uncertainty followers have to cope with when sampling a rather low number of waggle runs. The precision of the dance message might be increased by other signals though. The wing buzzes for example might mark the very body orientation that

corresponds to the feeder's direction. Unfortunately, I was not able to detect the timing of the wing buzzes visually in our video recordings since the low lighting conditions we used did not allow for high shutter speeds and thus lead to a high amount of motion blur. The use of an electrode to capture electric fields that are produced by the movement of charges on the wings enabled me to detect the wing buzzes. However, the temporal resolution of the video recordings does not allow pinpointing the buzzes to certain times within the body oscillation. While Esch (personal communication) did not find a synchronization of the buzzes, Uwe Greggers (personal communication) found hints that it might be so in some individuals. Using the honeybee robot, we would be able control the timing of the buzzes and test this hypothesis.

We found that the two angular measures yield a significant difference in the divergence angle. This angle is either assessed by comparing the means of left and right waggle runs (method A). Or it is measured "sequentially", i.e. only consecutive waggle runs are used to collect the angular differences which, in the end, are averaged (method B). Both divergences differ with respect to the angular measure used. The orientation measure (based on the average body orientation) always yields larger divergences than the direction measure (that refers to the direction of the waggle path). This might be explained by the transitions of the waggle to return run or vice versa. While wagging, the dancer bee often turns her body into the return run's direction but keeps the body's trajectory straight. To this might add that at the beginning of the waggle, the dancer might have turned not entirely into the right angle. To prove these assumptions, we recalculated the divergences discarding the first and last 10%, 20% and 30% of the waggle run. Leaving out the first portions, the difference of the two divergences gets even larger, entirely on the account of the direction measure. By discarding the end of the waggle the difference of the two angular measures drops to  $4^\circ - 5^\circ$ , which still is extremely significant ( $P < 0.001$ , see Appendix S1 of (Landgraf, et al., 2011) for the results of the recalculation). By discarding the first portion of the waggle we cannot observe an effect on the waggle orientation. That matches the fact that the angular and sideward velocities drop to almost zero right before the waggle run (see Figure 23). These results indicate that bees might fine-tune the divergence (tuned-error-hypothesis, see (Towne, et al., 1988) ).

Looking at real dance trajectories, the figure eight that is used commonly to describe the dance shape is observed rather infrequently. This is on the one hand due to the followers' vigorous physical efforts to keep close body contact to the dancer and, by doing so, being obstacles in her way. On the other hand the dance floor is usually no free space and also the followers cannot move freely. If the dancer's path is occupied she continues the turn on the spot or executes evasive maneuvers. Yet very effectively, a group of 2–3 followers usually clears the area for the dancer's subsequent waggle run with every turn they follow. By superimposing waggle periods (waggle-return-waggle-return) and created a two dimensional histogram of the body coordinates (Figure 25). That makes visible the figure of eight and illustrates that a dance period takes place on a very small area of approximately  $2 \text{ cm}^2$ . Together with the previous observation we infer that the return runs not only serve to return to the place where the previous waggle occurred. It binds a distinctive group to the dancer and utilizes their motion to keep clear a yet small area within a very chaotic and dynamic environment. Also the tight temporal dynamics of waggle and return phase lead to the notion of a dance period as an "information packet".

This analysis yields a solid basis to model the dance motion with highly realistic results. It therewith lays the foundation to imitate the complex spatio-temporal dynamics of associated stimuli. The proposed model is able to produce trajectories for a feasible, i.e. naturally observable, range of parameter values. We ran the model with natural parameter combinations (by measuring durations, motion speeds, etc. from video recordings) for dances advertising food sources at 300 m and 600 m distance and always obtain almost symmetric, figure-of-eight trajectory shapes. If we feed the model unnatural parameter sets, e.g. a high waggle run duration but a low return run duration, we would still obtain a trajectory - but only poorly resembling natural dance shapes. Furthermore, the model does not explicitly verify if the trajectory is resulting in motor speeds that exceed their limits. For a wide range of still plausible parameter sets, however, the robot should be designed to be able to drive the path computed by the model.

Future recordings of dances and upcoming recruitment experiments studying the ability of the robot to convey directional or distance-related information will provide the basis for the generalization of the current waggle dance model.

### 3.5 CHARACTERIZATION OF DANCE-RELATED STIMULI

In order to decide which of the reported stimuli should be reproduced by the robot, I applied a thorough literature search to learn which stimuli can be detected by the bees' sensory apparatus. Furthermore, some stimuli, e.g. the electric fields, have not been investigated in detail before and one might still question their importance in the communication process. By testing stimulus replications and observing the effect on the behavior of the bees I created a foundation of personal experience that helped prioritizing the stimuli reproduction in the design process of the mechanical model. Most of those tests were not conclusive but still helped understanding the perceptual basis of an array of different stimulus types. Many tests were conducted with the help and advice of Andreas Kirbach, Uwe Greggers and Randolph Menzel, who I'd like to thank here as well.

#### 3.5.1 VIBRATIONAL SIGNALS

Vibrational signals carry meaning over short distances and thus serve as *local* signals with tight temporal and spatial limits addressing only a few individuals. The waggle dance exhibits the so called "dance sounds" that were described by Esch (1961) and Wenner (1962) independently but these may not be the only signals of importance in the dance context. In recent studies the "stop signal" was hypothesized to interrupt the dance and trigger the exchange of nectar samples (it has been called also the "begging signal" (Michelsen, et al., 1986) ). Experimental evidence indicates that the stop signal might serve as a negative feedback to dances in swarm decision making (Seeley, et al., 2012) or foraging recruitment (Nieh, 1993; Pastor, et al., 2005) signals might also serve to improve the success of tremble dances resulting in an increase of nectar influx processing (Nieh, 1993).

#### EXPERIMENTAL SETUP

In order to test the sensory basis for the reception of vibratory signals, and foremost the (known) stop signal, I conducted an experiment in which I tested different vibrational stimulations with varying parameters such as frequency, amplitude and duration of a pulse. I used a computer program to create simple sine waves of a given parameter set, saved them as an audio file and then them played back using an active speaker. In a first row of tests, the speaker was held directly in front of an aperture in the glass window. Keeping the amplification of the device constant, I played back the sound in increasing distances to the comb surface.

In a second experiment, the speaker was connected to the hive's wooden frame rigidly using screws through the speaker's casing. Vibrations were thus fed directly into the hive. The amplification was increased in three steps. The region of the comb was recorded on video at 100 Hz with diffuse daylight illumination. The effect on the bees' body motion was captured by tracking sparse optical flow fields and averaging the motion of all flow features for each inter-frame change. The onset of the sound (or vibration) was marked in the video using a LED light that was switched on while the sound was playing.

#### RESULTS

Generally, the effect on the bees is, as described earlier, an instant stop of almost all bees that stand on the comb surface. Figure 26 shows how almost immediately the average activity, expressed as the mean motion over two frames in pixels, is reduced by more than 50 %. The effect is strongest shortly after stimulus onset. Bees obviously habituate to the stimulus, as the average activity increases over time. However, the activity measure does not recover the normal value even after 10 seconds, a duration which is supernatural. The effect is observable over all frequencies tested (200 Hz - 1000 Hz). Concurring with Esch, the effect cannot be observed when the speaker is not coupled to the frame of the hive, i.e. the vibrations from the emitter are not

transmitted to the comb. However, a very loud sound excites an oscillation of the plastic cover plate and bees walking over the plate stop when the signal is turned on as well.

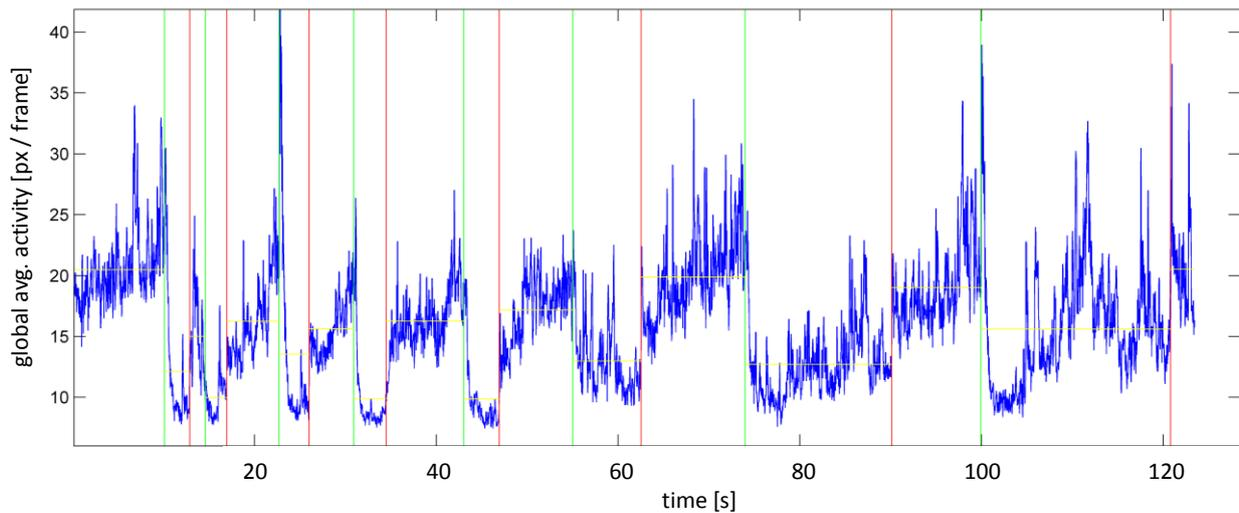

**Figure 26:** Averaging the length of all available optical flow vectors per frame yields a general activity measure depicted in the above plot as a blue line. The vertical bars denote the stimulus start (green) or stop times (red). Horizontal lines (yellow) depict the average activity in the sequences with (S) or without (N) the stimulus. The experiment shows the effect of increasing stimulus- and “rest” durations on the motion activity. Short stimulus durations have a relatively strong suppressive effect on the average motion. Bees seem to habituate to the stimulus after a few seconds such that the average activity in long stimulus phases is higher than in short periods. After each stimulus the activity recovers to a normal level ( $\sim 20$  px / frame) after a few seconds. The effect is extremely significant (t-test;  $P < 0.001$ ) for all pairs S-N and N-S.

## CONCLUSIONS

The results indicate that the following notions, previously reported in the literature can be confirmed:

- a) Stop signals are very likely transmitted via the substratum
- b) most likely mechano-receptors in the legs are stimulated and lead to the reception of vibrational cues
- c) perception of air-borne sound, if possible, does not lead to a measurable change in body motion.

Furthermore, optical flow tracking can be used to *quantify* behavioral changes – however, this only holds if those are reflected in a change in motion. Assuming vibrations are produced by a bee on the comb surface those vibrations spread over small distances through the cell structures and enter the body of surrounding bees starting with their legs. Though, a follower bee can touch a dancer with her antennae and receive meaningful stimulation of the antennae as well. It remains unclear whether the modality over which a stimulus is received determines the meaning of the signal. A stop signal received strongly at the antennae might convince the dancer to provide a nectar sample, whereas the sole reception over the legs might lead to an interruption of the dance only.

The role of the stop signal in the waggle dance context is not fully understood. A recent study indicates that it serves as a negative feedback mechanism to control the hive’s foraging efforts. Although bees perceive this signal only over the comb surface, it is audible as sound as well. If the robot would be supposed to perceive the signal, a simple microphone can hence be used.

## SIDENOTE

There may be unknown signals or meanings for known signals that follower bees send back to the dancer. After testing the robot in the summer 2010 I was intrigued by the way dancers and followers seem to “agree” on starting a dance. It was unclear to me why the dancer interrupts a dance for trophallaxis. Also, she sometimes interrupts a dance to change her location and then continues to waggle. The duration of the return run might

exceed the average duration substantially and when she starts to waggle again, there is always at least one follower ready to sample the waggle run. When a new follower approaches a dancing bee, she seems to have no problem synchronizing to the dance; she finds the waggle portion, turns into the right direction in the return run, and so on. The dancer's waggle rhythm alone might be sufficient for the synchronization (and if it was like that, the robot's design wouldn't have to have an adequate sensory system) – however, if there exists such a feedback signal, I would have to implement it.

### **3.5.2 LAMINAR AIRFLOWS**

Tested already in the laboratory, we knew that the artificial wing apparatus could produce airflows that can be detected more than a centimeter behind the robot; even with a very simple and apparently insensitive measuring device (see Part IV – The Honeybee Robot, Chapter 7). The question then was if those airflows can be detected by bees as well. The honeybees' proboscis extension reflex (PER) is a behavior broadly used to test learning and memory abilities (Bitterman, et al., 1983). To this end, bees are conditioned to a stimulus, e.g. a certain scent, and rewarded with sugar solution. After a number of training trials in which both stimuli are presented with an overlap in time, the bees are tested by just presenting the conditioned stimulus (CS) without the following reward. The response of the animal is (in anticipation of the reward) the extension of the proboscis. This behavior can be used to infer numerous things – in our case, the ability of the bee to detect the stimulus. This simple procedure has a flaw: if the bees do not show learning it doesn't have to necessarily mean that they don't perceive the stimulus; it would be a strong hint though.

In the following experiment bees were trained to detect an airflow produced by the robot. A detailed description of the experiment is given in (Kirbach, 2013).

#### **RESULTS**

Bees are able to detect the airflows produced by the robotic wing. However, only 45 % of the bees showed a response after an unusual high number of 12 trials. Figure 27 shows the portion of bees that responded with the proboscis extension after presentation of the conditioned stimulus over the number of trials. The first bees did respond not before the 10<sup>th</sup> trial.

#### **CONCLUSIONS**

Bees can detect the airflow pattern behind the artificial bee body. It remains unclear whether the strength and the shape of the flow are comparable to airflows in natural dances.

The "slow" learning could have several reasons:

- a. The wing apparatus might not have worked properly in some of the trials (e.g. the strength of the stimulus might have fluctuated), hence the bees might have been presented with rewards for conflicting situations.
- b. Even though the stimulus could be detected the PER-paradigm might be suboptimal to reflect this. For an average forager, mechanical stimuli can be found everywhere in the environment and might therefore be less salient than odors.

### **3.5.3 ELECTRIC FIELDS**

Uwe Greggers, one of the principle investigators of the project Robobee, works with Randolph Menzel and oversees many of the technical aspects of the work of Prof. Menzel's group. In the context of the bee dance, (Greggers, et al., submitted) indicates that bees not only produce electric fields in the waggle run but followers are likely to receive those fields as well. Theoretically, those fields are produced when dancers oscillate their wings. Since they carry static charges all over the body (and the wings are typically very dry and easily hold their charges) from the static perspective of a follower a dynamic field potential is created. Charges can also be found on the antennae or body hair of the potential receivers and should move in the weak field. Thus,

mechanoreceptors (attached to body hair or in the pedicels of the antennae) might be able to translate the dynamic field into meaningful (mechanical) stimulation.

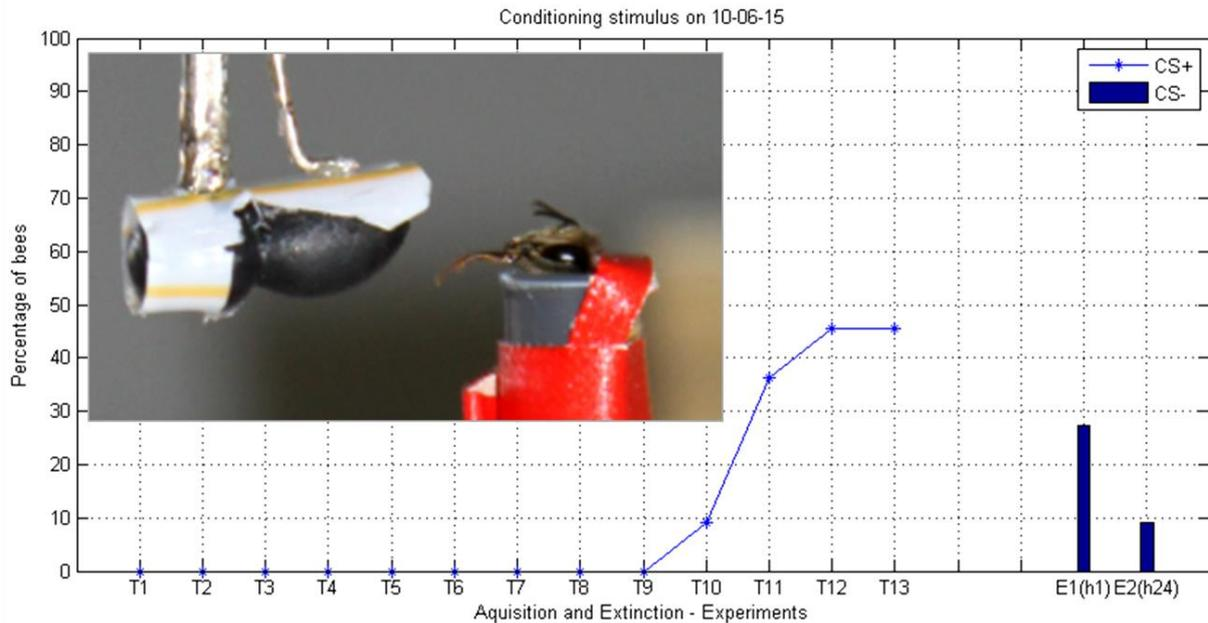

**Figure 27:** By associating a reward (a drop of sugar water) to the wing vibrations a classical conditioning paradigm is used. Once the bee has learned this association she responds with the extension of her proboscis in expectation of the reward. If this reaction can be observed the animal is able to perceive the stimulus. The above picture shows a harnessed bee in a plastic tube extending her proboscis. To her left, the replica is producing wing vibrations. The figure depicts the “learning curve”, i.e. the amount of bees that responded to the stimulus. Trials T1 to T9 were resulting in no responses. After twelve trials 45 % of the bees were responding. The memory could be extinct by two trials pairing the stimulus to no reward. Figure courtesy: Andreas Kirbach (Kirbach, 2013).

In an early stage of the project RoboBee, when Uwe Greggers formulated the hypothesis bees could use electric fields rather than airflows to transmit information, I recorded dances of honeybees with a video camera and a special electrode to capture the electric fields in the dance. The device was built by Greggers and consisted of two components, a KCl-electrode<sup>5</sup> and a pre-amplifier. The electrode, a ring of silver wire, 3 cm in diameter, in a transparent plastic disc that contained a small volume of a KCl-solution was connected to the preamp which amplified the signal as close to the source as possible to avoid noise in the later stages of the signal path. A second device was built together with Uwe Greggers and Taner Topal: a grid of operational amplifiers. It was planned to localize vibrational signals of all bees on a 10 cm x 10 cm square of the comb surface. The amplification level of the grid was not feasible for a precise trilateration of the signal. However, I used it for recordings that characterize the vibrational signals, as shown in Figure 29.

## RESULTS

The electro-recordings show short pulses of 280 Hz within the waggle portion of the dance. It is likely that those recordings reflect the wing oscillations. Figure 29 shows the original signal and several band pass filtered variants.

## CONCLUSIONS

It is possible to measure vibrations in an unconventional way using an electrode. The electric fields produced by the dancer are strong enough and the equipment sensitive enough to register them in detail. There are vibrational signals in the dance (the “dance sounds”) but also outside it. Several questions remain unclear:

<sup>5</sup> Potassiumchlorite

- Although the electric fields drive mechano-receptors that might be excited by vibrations and particle oscillations as well, the electric field is distributed farther and is not blocked by neighboring bees. It is unclear whether the fields are essential for the information transfer.
- It is still unknown which bee produces buzzes outside the waggle run and whether this serves a specific function.

Question 1 can be addressed with the robotic bee. A way of investigating the second question is a combination of the grid mentioned above (or the one described in (Greggers, et al., submitted)) and a video camera to allocate the production of buzzes to individuals and analyze their preceding and subsequent behavior.

### 3.5.4 DANCE PHEROMONES

Thom et al. (2007) indicates that a certain mixture of two alkenes and two alkanes (the “waggle scent”) is specific to the air above and around the dancer and, if blown into the hive, increases the number of animals exiting the hive. Semio-chemicals, like the mentioned mixture of carbohydrates, might play a role in general, “global” information transmission. E.g. the dance pheromone might serve to arouse animals, for increasing foraging efforts, etc. On the other hand the pheromone might just have disturbed the hive and thus increased the activity. Still, there might be a chance that the scent has a function, and if so, it might be necessary to provide the robot with such a scent. To answer this question, a PER-test was conducted by my colleague Andreas Kirbach investigating the ability of bees to detect it. The experimental design is described in (Kirbach, 2013). The results show that even with varying methods of application, the scent could not be learned by the bees.

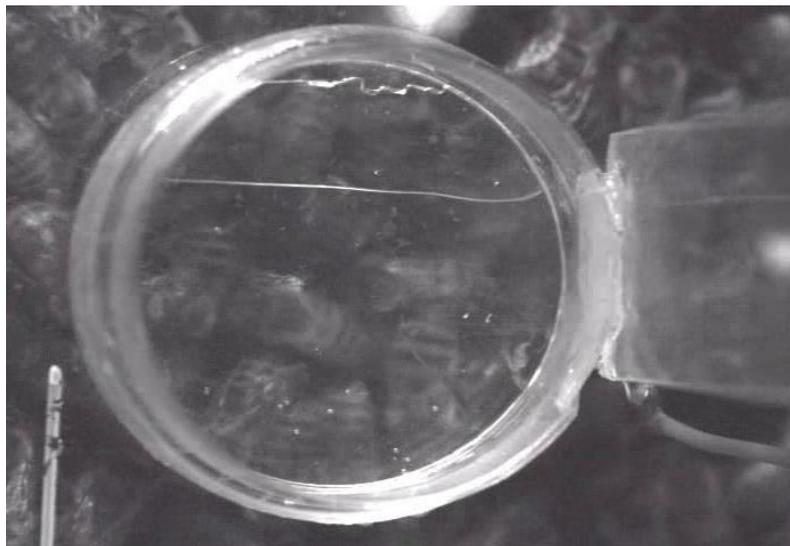

Figure 28: The KCl-electrode was held closely to the glass plate of the observation hive. Dancing bees could be observed through the KCl-solution.

### 3.5.5 SECONDARY STIMULI ASSOCIATED WITH THE ROBOTIC DANCE

When using the robot in the hive a number of stimuli are always associated: Opening a window to the comb introduces a change in the micro climate of the hive: the temperature and humidity might change, environmental odors might enter the hive, airflows might enter the hive, etc. Also the use of artificial light might disturb the bees and prevent “normal” behavior towards the robot. I used the optical flow method to measure the effect of each action, i.e. opening the hive and using artificial light.

#### LIGHTING

I used infrared light to record a reference sequence prior to switching to red or white light. An infrared pass filter was attached to the camera's lens and the lighting was kept switched on for all following treatments. The recording was then fed to the optical flow tracker and the motion fields for each setting were compared. Intriguingly, all lightings have an effect relative to the reference lighting. Although bees should be only weakly

receptive for red light the amount of motion increases for a short amount of time. After 10 seconds, this effect has vanished, the bees might have adapted. The same holds true for white lighting, but the effect is stronger.

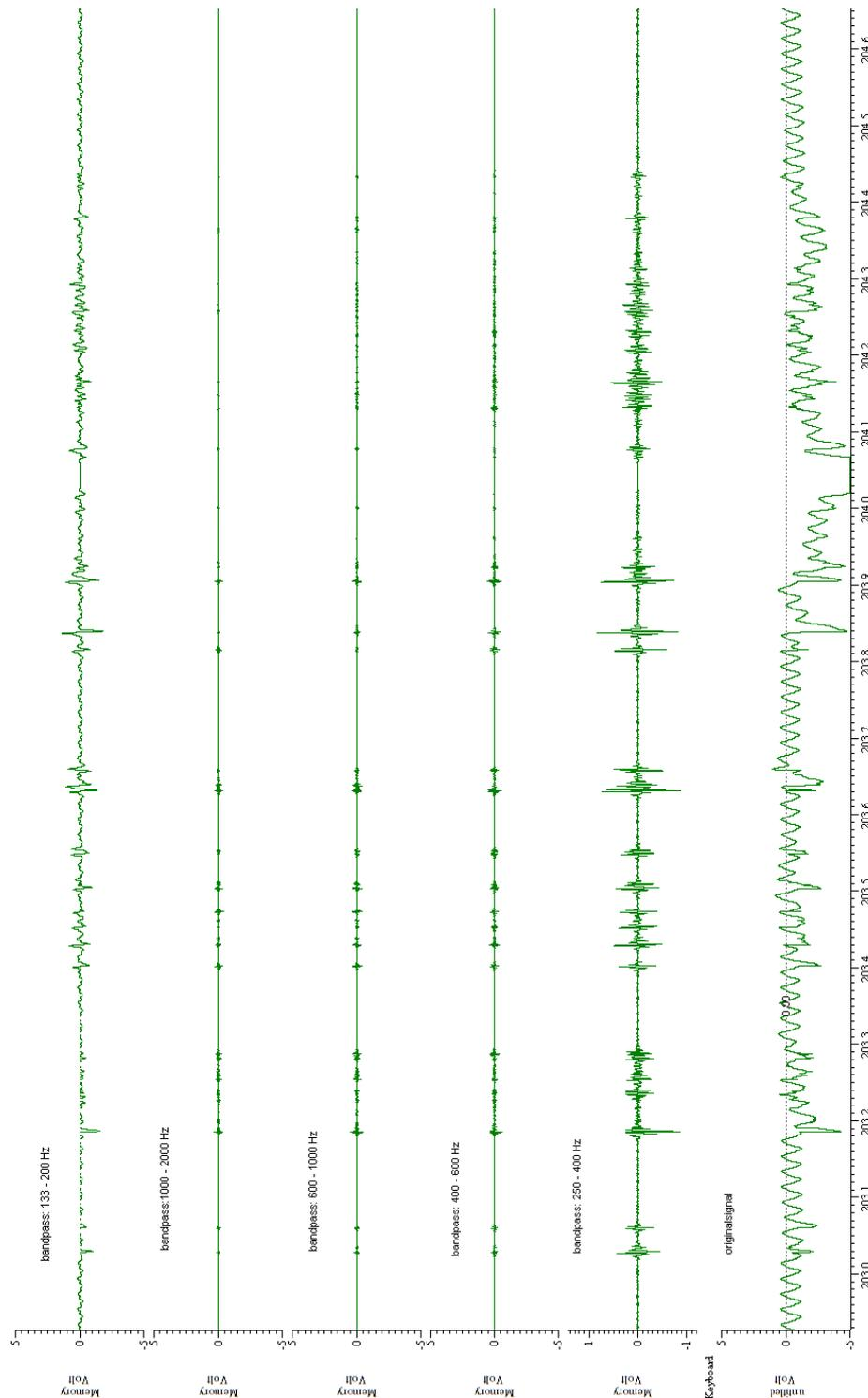

**Figure 29: An operational amplifier integrated to the comb surface was used to record any activity in the hive. The original signal, the right-most, shows substantial 50 Hz noise. I used several band pass filters whose response is depicted in the remaining channels: (from left to right) 133 Hz – 200 Hz, 1000 Hz – 2000 Hz, 400 Hz – 600 Hz, 250 Hz – 400 Hz. The latter frequency band shows strong responses. Pulses of approximately 10 ms duration can be observed even without apparent dancing.**

## OPENING THE HIVE

Upon opening a window to the hive the majority of bees in the open area changes their behavior. They run around more quickly, more bees arrive from other parts of the comb, the open spot gets more and more

crowded until – after only a few minutes – a curtain of bees is formed and not dispersed before the window is closed again. This effect seems to be dependent on environmental parameters. The duration - from opening the hive until the curtain has formed – varies significantly from only a few minutes up to 20 minutes. I did not study this effect in detail since it became obvious that controlling those environmental parameters might be too time-consuming.

### **3.6 CONCLUSIONS**

This chapter gives an overview of my analyses of the dance communication system. After reviewing basic details on honeybees and honeybee colonies, I describe how experimental work is conducted. This involves keeping and maintaining a bee hive, training bees to remote field locations and recording the bees' behavior on video.

A large part of this chapter is concerned with a detailed analysis of the bees' dance motion. Prior to the statistical investigation, I describe the development of an algorithm for the extraction of dance trajectories from video recordings. The statistical analysis of this data yields a precise picture of how bees dance and which of the properties exhibit a low variance. Temporal parameters, the waggle - and return run duration seem to be tightly tuned which suggests significance in the communication process and the importance of their precise reproduction. The proposed dance model captures the body motion naturally. By altering parameters of the model it is possible to produce unnatural dance paths as well. Thus, the proposed dance model gives full control over the motion of RoboBee.

A following section on preliminary experiments for the characterization of dance related stimuli describes the work prior to actually building the robot. This analysis serves primarily to learn about the sensory capacities of bees. The results are applicable to the construction process of the robot and are valuable for the assessment of later experimental results with robotic dances.



# THE HONEYBEE ROBOT

Details of Implementation: Mechanics, Electronics, Sensors and Software

## **4.1 INTRODUCTION AND PRELIMINARY WORK**

### **4.1.1 BEGIN OF THE PROJECT**

By the time the first prototype of RoboBee was built, I was not involved in the project yet. In the year 2006, before I finished my Master's thesis, my colleague Hamid Reza Mobalegh designed and constructed a minimalistic bee robot. Its design principle was different from the one built by Axel Michelsen. Based on a parallel motion mechanism, this and a follow-up version built by myself were conceived and constructed before experimental trials. By the time the first experiments were finished conducting, by the end of 2007, we soon learned that using a plotter-like positioning system, similar to Michelsen's robot, would be best for the ensuing versions of the robot.

This chapter covers a short report on the research that led us to the final design, a thorough description of the final system, including mechanics, sensors, actuators and software. A separate section describes the computer vision system that allows the robot to sense and react on its environment.

### **4.1.2 THE ROBOBEE TEAM**

Most of the final system's features were implemented by Michael Oertel who compiled some of the following results in his Master's thesis (Oertel, 2009). Our collaborators Randolph Menzel, Uwe Greggers, Rodrigo De Marco and Andreas Kirbach also had substantial influence on some design decisions and concepts. RoboBee, as the result of a team effort, would look different if I had built it alone.

### **4.1.3 THE ROBOBEE-PARADOXON, LIMITATIONS AND SIMPLIFICATIONS**

The construction of a robot that is used within an animal society should be governed by knowledge about the system it is supposed to be employed in. In the case of the honeybee dance communication many of the properties were, and still are, unknown; yet to be discovered with the help of the robot to be designed. For example it is unknown how to make to robot be accepted as a nest mate. It is unknown if it requires "chemical camouflage", if the body of the robot needs to be particularly textured or even if interactive behavioral cues with colony members are required to avoid being attacked. Those questions have to be answered before any experiment can be conducted that addresses the essential signals in the waggle communication. Those questions are obstacles on the path to a functioning honeybee robot but may shed some light on our understanding of the complex interplay in a bee colony.

Any system's design process is also constricted by technical, monetary and personnel-related limitations. For example, it is impossible for me to build an autonomous honeybee robot that walks and dances on the comb surface just like honeybees do. Technically and monetarily, there is no way of building even the simplest model of a honeybee leg that could be used to propel an autonomous insect. We neither have the batteries of such small dimensions and power requirements. And even if we had, such project would require staff from various fields: again, a monetary issue.

Feasible simplifications must be made to make the construction *possible*. Sufficient complexity must be maintained for the system to *work* under natural conditions. The question now is: what are feasible simplifications and how do we define “it works”? What is a model of the honeybee dance that exhibits the necessary complexity and is sufficiently simple to be built? What are essential cues to be implemented? How can they be imitated? How precise do the motions have to be, or conversely: how much variability must the biological system be fed with?

Those questions have to be answered prior to designing a system. Do I *believe* that the dorso-ventral motion of the dancer bee carries information or by any chance is important for the followers to “read” the dance information from the dancer? If I affirm this notion I would have to add another motor, circuit boards and code for the depth motion. This increases complexity of the system and its analysis. However, if the model oversimplifies the biological system, how do I recognize that? This is by far the most difficult question in the design process of the honeybee robot. How do I recognize that the system is too simple or incorrectly configured?

Observing, assessing behavior and calculating the statistical effect of different treatments is the basis of most biological research and also is for the work with RoboBee. Those results are used to refine a prototype in an iterative process. There is an assumption embedded in this approach that might not be true. Let us think of an abstract complex stimulus ABC which is composed of single components A, B and C. Applying ABC to the natural system, we obtain an effect  $e(ABC) = E$  on the animals’ perceptual system which drives a certain behavior which yields our observation  $o(E) = O$ . We now want to test the effect of the single component A on the system. The stimulus A has a variety of possible characteristics and by exposing different values for A to the colony and measuring its effect we expect our observations to indicate the “optimal A”. This requires a definition of optimality, which might be given by our observations in the natural reference. For a certain value of A we expect  $o(e(A))$  to be close to  $o(e(ABC))$ . Since we do not know  $e$  nor how it is translated in observable behavior, this assumption might be erroneous. The natural system might show arbitrary behavior under single stimuli like A, B or C even for their correct respective values. The combination of “atomic” stimuli might be perceived as an entire new stimulus resulting in a different translation in observable behavior. For example, the optimal wing vibration characteristics might even result in aggressive behavior because the embodiment, the scent and all other stimuli are missing. The following metaphor might deliver a good picture of the problem: Imagine a combination lock with three rotatable discs. The lock can only be opened by rotating all discs into the right position – the key combination. Even the slightest mismatch of only one disc prevents the lock from being opened. Since the notches inside the discs are invisible there is no way of measuring the quality of a certain combination – the observable behavior is binary: it either opens or it doesn’t. However, the theoretical lock is harder to crack than the actual physical combination lock. Pulling the pin outwards, the right combination of each disc results in a slight click. The system has revealed its notches (i.e. it has shown a behavior). The hope is now, that the honeybee dance exhibits its own slight clicks.

#### **4.1.4 PRELIMINARY WORK**

##### **INITIAL PROTOTYPES**

In the year 2006, Hamid Reza Moballegh, by that time PhD student in Prof. Rojas’ lab and close co-worker of mine conceived and constructed the first robotic honeybee robot since many years - the last reported honeybee robot was built by Michelsen in the late 1980s (Michelsen, et al., 1989).

Hamid’s new robot was based on two servo motors for planar positioning and a stepper motor for the rotation of the bee replica. Figure 30 depicts its design principle. The carbon fiber rod carrying the dummy is affixed to the stepper motor axle using a flexible joint. The rod was attached to two con-rods that connect to servomotors. These pull or push the central rod along a curved path. For small changes in motor angle one could assume linearity of the tip deflection with only small positional error. The tip of the rod, i.e. the artificial body,

also moves on a spheroid surface. Unlike Michelsen's robot, this new prototype was light-weight and small. Its motors could be packed into a 10 cm<sup>3</sup> cube.

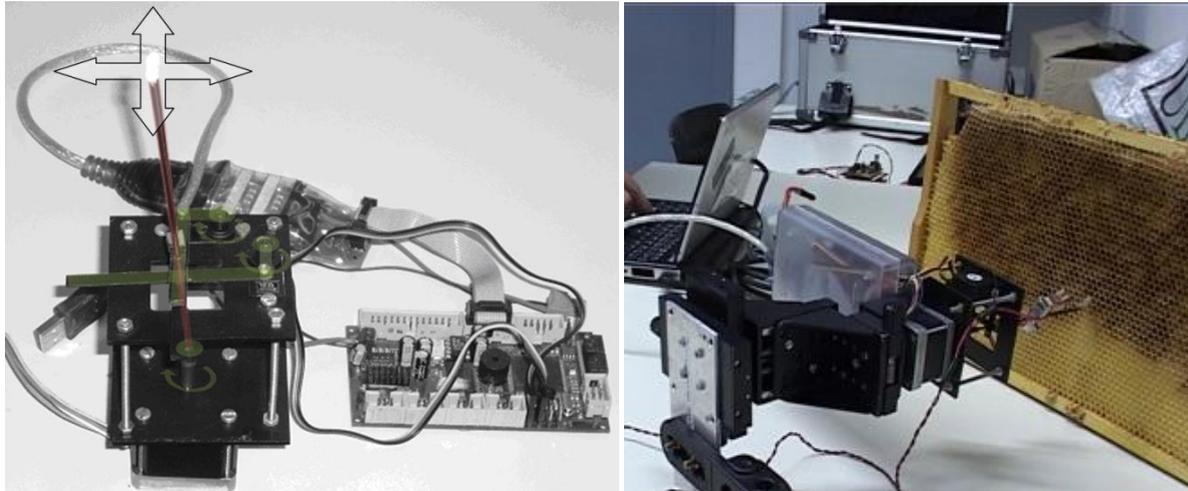

Figure 30: First version of the honeybee robot. Two servo motors in the upper plane moved a carbon rod in parallel. The rod (marked with red color) was connected to a third motor for the rotation and a silicon bee model. The complete system, as depicted in the figure, was extremely portable and light-weight.

The robot could be configured and ran with a graphical user interface. A path with a constant numbers of waypoints could be reshaped interactively using the mouse to drag the waypoints closer or farther away from each other. Each waypoint displayed a point in time, so a longer distance between two waypoints would result in a faster motion.

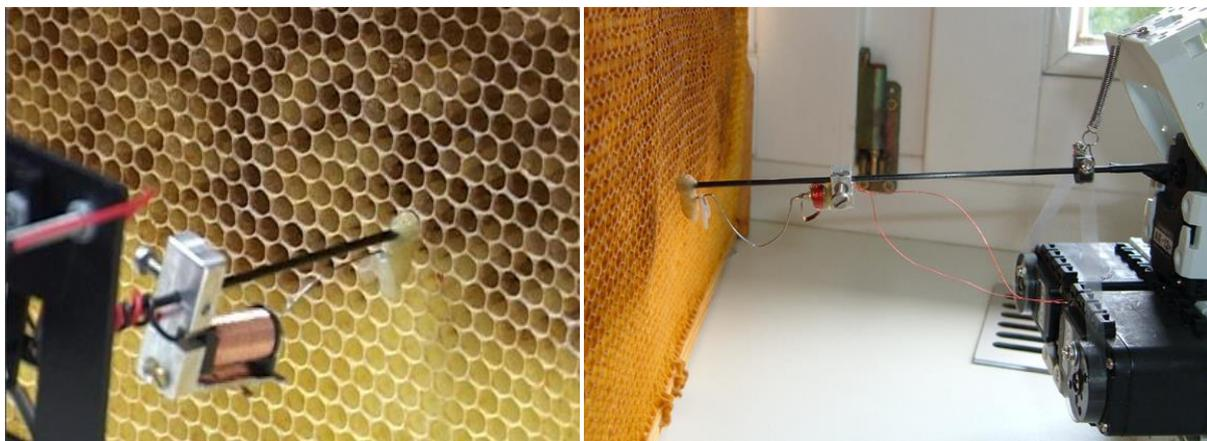

Figure 31: Improvements of the robot. Left image: an electro-mechanical driver was attached to the carbon rod to produce wing vibrations. The wings itself were not fixed to the body model and vibrated in the dorso-ventral axis only. The right image shows a newer version using the same parallel motion mechanism. The design used thin plastic belts that were pulled by two servo motors, a third motor was used for the rotation.

Later, the central carbon fiber rod was extended by a custom solenoid wing driver. It was soldered to a wire that connected to a pair of wings close to the body of the bee robot (see Figure 31).

This additional load introduced a great deal of mechanical noise to the system. The replica would shake at every move it made. Also, the stepper motor used for the rotation was not sufficiently strong. The waggle amplitude, i.e. the angular displacement was less than 2 degrees, less than real dancers do in average.

It became clear that these first steps towards a honeybee robot did not account for the complexity of the bee dance.

This basic design principle was copied in the second prototype. The central rod was moved with cables that pulled and if they let way, a spring centered the rod again. As the rotation motor was needed to be strong, we used a Faulhaber DC motor which I augmented by a rotary encoder. The waggle frequency could be met by ensuring an angular amplitude of more than 10 degrees. Field tests, however, showed that an intrinsic property of the system is disadvantageous for the use in the hive: Since the tip of the rod moves on a spheroid surface the bee replica would lift up over the comb surface more than naturally. This effect can be diminished by using a longer central rod. However, this makes the system more vulnerable for mechanical noise.

### **PLOTTER-BASED POSITIONING SYSTEM**

In 2008, I decided to start completely new. The old parallel motion design had advantages in system size, but could not overcome its built-in flaws. With Michael Oertel a new member of the group began his work and helped changing the robot to a precise but rather bulky positioning system. He overlooked the implementation of a serial design mechanism, similar to Axel Michelsen's approach. The goals were set as follows:

1. Precise positioning on a surface area parallel to the honey comb
2. Arbitrary positioning of the robot body on the comb plane
3. Motion parameters adjustable and similar to those extracted by the dance analysis
4. System should be able to carry significant workload for additional sensors and actuators

We identified a flatbed plotter as a sufficient hardware basis and bought a Roland D-XY 1300 on eBay. All following prototypes are based on this system which in the following sections is described in full detail. The robot did undergo many improvements. In the following sections I focus on the final prototype. I omit a detailed report on intermediate designs. The interested reader can find a short description for each year's prototype in Chapter 5: Experiments.

## **4.2 DESCRIPTION OF ROBOBEE**

### **4.2.1 MECHANICS**

The robot's positioning system is based on a Roland flatbed plotter (DXY- 1300). A plotter can be used for moving a pen over a drawing surface or a cutting knife through Styrofoam. The basic motion principle is a serial mechanism: the pen carriage moves along one axis (the rail) that in turn can be moved in the orthogonal direction. The carriage and the rail are driven by gear belts that connect to stepper motor axles.

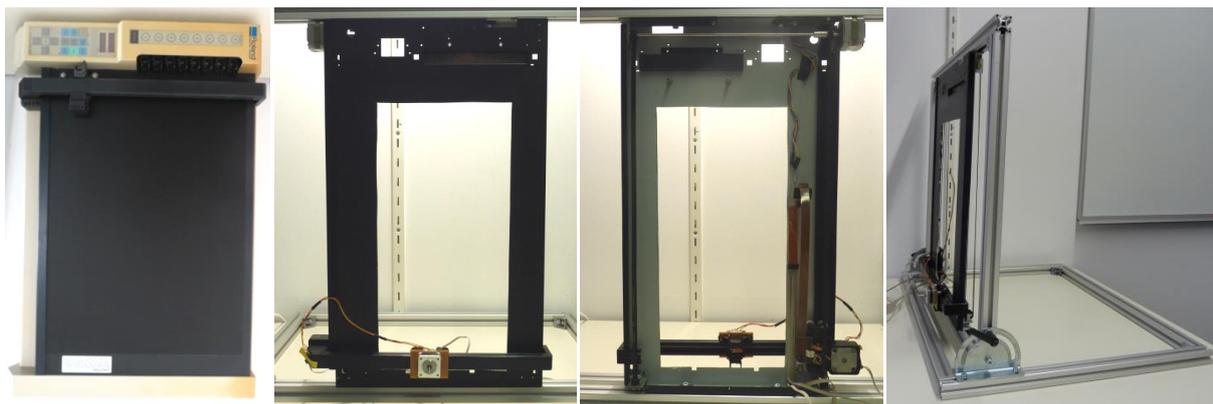
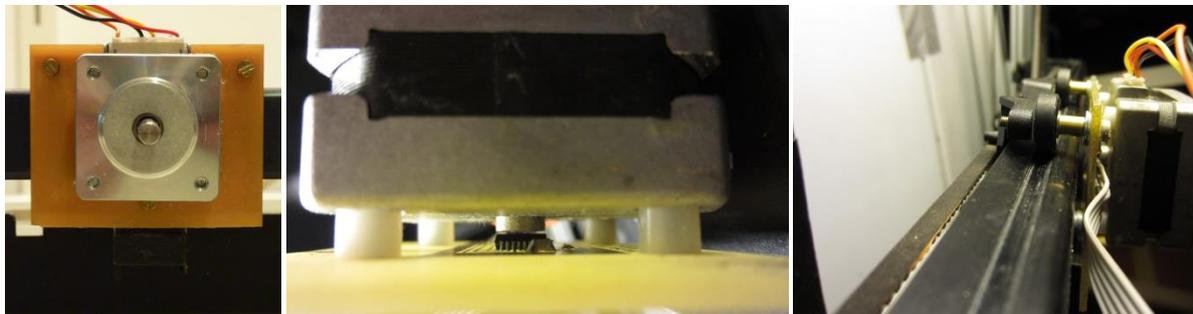

**Figure 32: The Roland plotter (far left) was the basis for the honeybee robot. All electronics were removed and the drawing surface was cut out. The two center images show the remaining of the original system. The plotter was then fitted into an aluminum frame (right photograph).<sup>6</sup>**

The built-in electronic circuitry was removed completely. Custom circuit boards for driving the actuators, reading the sensors and communicating with a personal computer were developed and two additional stepper

<sup>6</sup> The photographs were kindly provided by Michael Oertel.

motors were added to augment the robots abilities: One motor, responsible for the orientation of the bee robot, is affixed to the pen carriage, and a second stepper motor is added for the trophallaxis pump for providing sugar samples. A window was cut out of the plotter's surface to make the robotic dance observable from behind. The plotter is fitted into an aluminum frame for higher stability and for operating it in an upright position. The frame can be pitched to align the robot's motion plane to the comb surface. A metal rod is fixed onto the third motor that carries the bee body, the cameras and all stimulation units. The bee replica is attached to the metal rod using a plastic elbow. The motion of a dancing bee during the waggle phase has a rotational component and a lateral translation. The elbow element is used to hold the body eccentrically (away from the center axis given by the rotary motor axle) such that only the third motor can generate the waggle motion. Although the rotational amplitude is then fixed to the translational amplitude (and vice versa) the system gains mechanical stability compared to a waggle that is produced by all three motors. This design restriction was supported by the results in Chapter 3: Analysis of the Dance. The waggle run property *orientation amplitude* was found to be very variable and thus not likely to carry meaning. On the other hand it is still possible to change the angular amplitude and leaving the displacement unchanged by elongating or shortening the elbow.



**Figure 33:** The pen holder was replaced with a third stepper motor (left image) which then moves the bee replica and all signal actuators. A magnet with a polarization orthogonal to the axle of the motor is glued to the end of the shaft (center image). Using a special contactless rotary encoder<sup>7</sup> the motor's orientation can be read out with very high precision (12 bit). The circuit board serves also as the base of the carriage (right photograph).

This system was kept for the following years (2008 – 2012) and was altered and improved after each experimental season, i.e. from October to May. The most important design change was introduced in the year 2011: a plastic base plate fixed to the carriage moves along all translational movements. It holds four telescopic brass tubes. The tubes are flexible in length and serve as holders for a second thin plastic cover plate. This transparent sheet is used to cover the window to the comb surface when the replica is inserted, separating the in- and outside. This reduces the disturbance of the colony substantially and prevents the formerly observed “bee curtain” that was likely a result of the change of the hive's climate (see also Chapter 5: Experiments for a detailed description of the behavior).

<sup>7</sup> <http://www.ams.com/eng/Products/Magnetic-Encoders/Rotary-Encoders/AS5045>



Figure 34: Inserting the replica requires a window to the comb surface. In order to cover this artificial entrance the robot carries a thin transparent plastic plate. It is held by four flexible telescopic tubes, essentially two brass tubes with a ball-pen spring. The central rod that holds the replica reaches to a hole in the thin sheet through which only the replica is run and presented to the inside of the hive.

#### 4.2.2 ELECTRONICS

The electronics for the robot have been designed from scratch for the following tasks:

- Communication with PC for setting parameters
- Autonomous operation in three dimensions (motion plane and orientation) plus stimulus space using sensor readings at high “frame rate”
- Semi-automatic operation using remote controls

Conceptually, the system is divided in peripheral processing units (two cameras, one remote control and a dedicated temperature controller) and the CPU on the main board. The peripheral units communicate with the CPU via UART, a low level serial interface. This distributed approach reduces computational load of the CPU. The function of the cameras is described in section Visual Obstacle Recognition 4.2.6, the temperature controller is reported on in section 4.2.4. The remote control is covered this section.

The main board comprises: a voltage supply, stepper motor control units, a USB interface, a relay board and the main processor. The power supply is fed 16 V - 20 V and it provides 5 V for the USB interface board and 3.3 V for the main processor and the two camera sensors. The USB interface is used for the communication of the main processor and the connected personal computer. The main processor, an ARM Cortex M3, based on a 32-bit RISC architecture, is responsible for the communication with peripheral processing units and the PC. It drives the actuators like the motor and wings. It also runs the dance model and integrates the results of the visual obstacle recognition.

A set of circuit board designs for the components of RoboBee is available online in the project repository: [www.robobee.eu/dissertations/landgraf](http://www.robobee.eu/dissertations/landgraf).

#### STEPPER MOTORS AND STEPPER CONTROLS

Three hybrid synchronous stepper motors (two-phase) are used for the motion generation of the robot (planar and rotary motion). The x/y steppers and the orientation motor have an angular resolution of 0.9° and 1.8° per step, respectively. This resolution is increased by factor 16 using micro-step motor drivers. A fourth, regular stepper motor is used to squeeze small drops of sugar water out of a flexible tube at the head of the robot. The motor controls translate rectangular signals (3.3 V) coming from the central processing unit to the two-phase step cycles for each motor. The signal encodes the velocity of the motor’s rotation, i.e. a given frequency of the rectangular signal is translated in the respective velocity of the motor (in steps per second). A velocity  $v = 0$  holds the position of the motor.

## ELECTRONICS FOR SIGNAL ACTUATORS

For the wing oscillations we use a stepper motor driver to drive a small speaker. Rectangular signals (5 V) of a given carrier frequency and pulse rate are produced by this circuit providing a sufficient amount of power. The trophallaxis motor is driven by another stepper motor driver. The motor squeezes drops of sugar water out of a small flexible tube. The velocity (amount of steps per second) for a specific amount of sugar solution was calibrated by measuring the size of the drop optically after a unit period of time (10 seconds). Body temperatures of 30 °C – 50°C can be produced by two SMD resistors built in the thorax of the bee body. They are fed a constant voltage by using a MOSFET that is switched on and off by a digital signal sent by the CPU. A small temperature sensor (DS-18S20) that is built in the replica close to the heating elements is read out by the CPU for continuous control of the heat production.

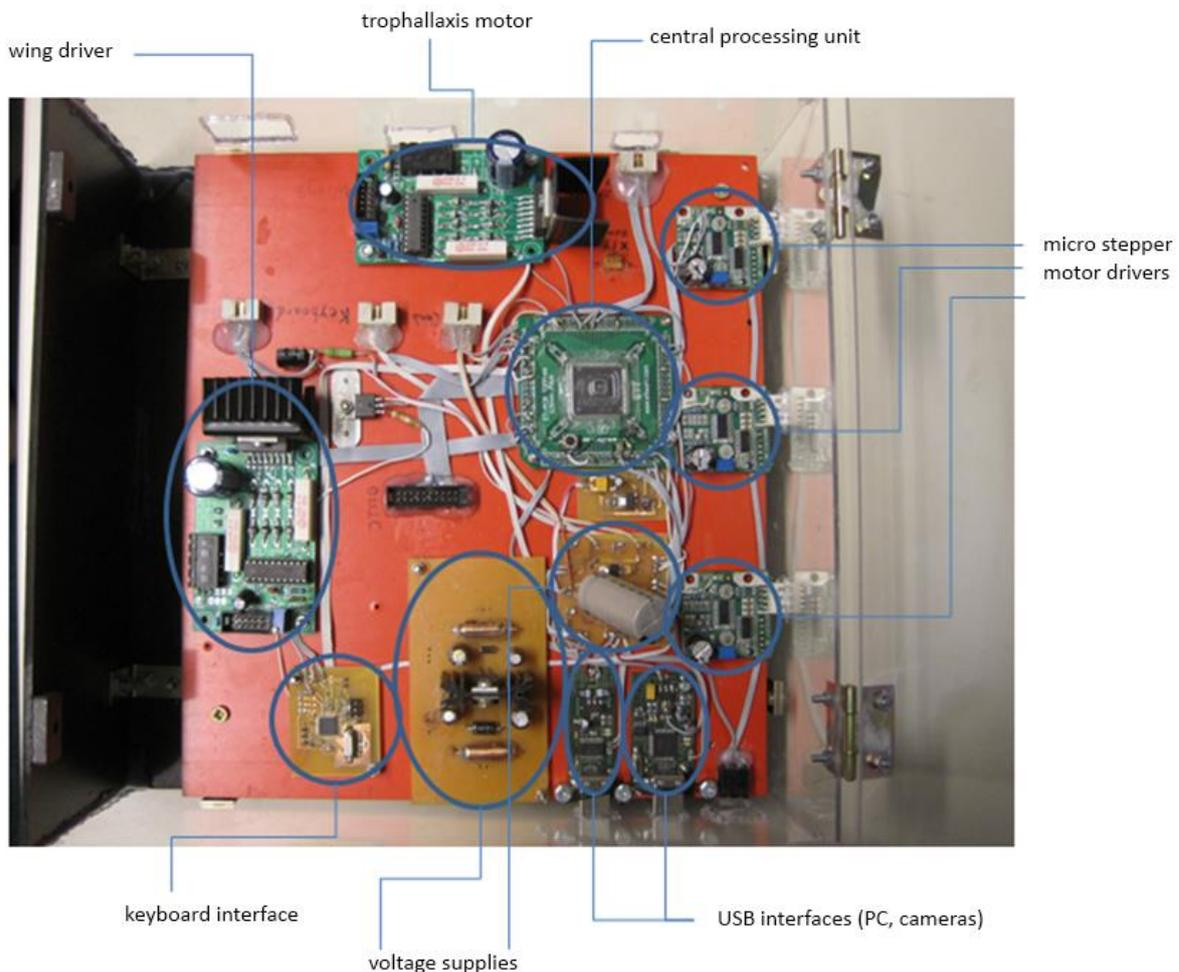

Figure 35: Photograph of the electronics. All important parts are marked and named in the image. Image courtesy: Michael Oertel.

## KEYBOARD AND JOYSTICK CONTROL

A keyboard mode was implemented to enable the experimenter to “drive” the robot in the hive manually. The keyboard was built by Michael Oertel. Four buttons for the planar motions, two buttons for the rotations, one button for the waggle run, an on/off switch and a velocity dial are integrated in the device that runs with an 8-bit microcontroller which is collecting information about the state of each button and sending serial packets (using RS-232) to the main processor of the robot. Similarly, an analog joystick can be used to steer the robot manually. The joystick's state is read out by the CPU of the robot. A description of the functionality of both the keyboard and the joystick can be found in section 4.2.9.

### 4.2.3 POSITION SENSORS

The robot reads positional data from a two sensors. The most important is the rotary encoder of the orientation motor. Since it is imperative for the experiments to keep the dance angle as set for all repeating experiments, this angle is sensed and controlled for in the dance program. The sensor is a contactless magnetic rotary encoder, commercially available from Austria Microsystems. Its angular resolution is 12 bit and hence more precise than the motor control.

A second sensor is a built-in end-position switch that signals when the rail of the plotter reached the lowest position. Since the robot is standing in an upright position, switching off the motors would lead to a free fall of the carriage with all its parts. Pressing a button in the graphical user interface or on the keyboard the robot slow drives slowly towards the rest position and gently parks after having received the end-position signal.

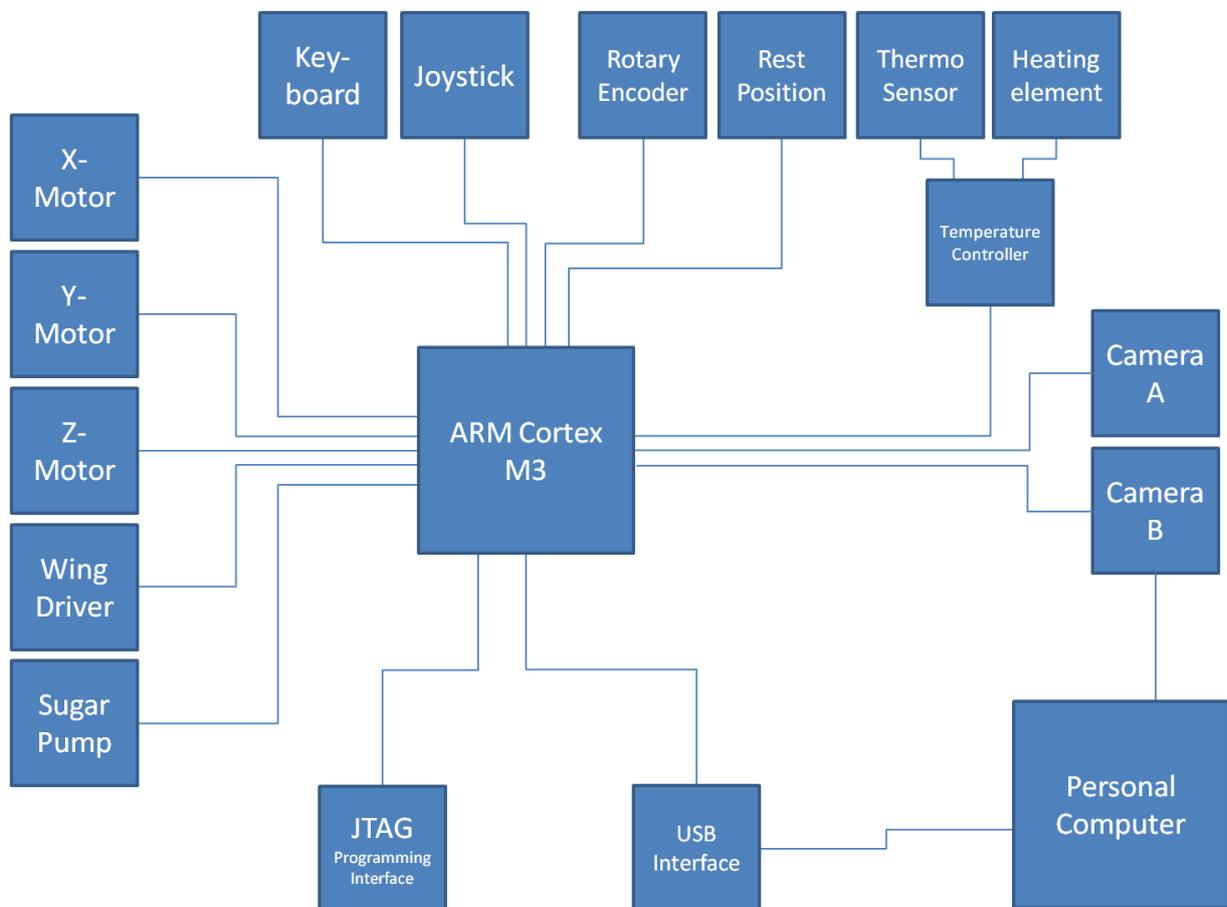

Figure 36: Schematics of the main board. The central processing unit connects to five step motor drivers (to the left), four of which actually control motors and the fifth used for the generation of wing pulses. The temperature of the replica is increased by switching on a simple MOSFET, controlled using sensory data coming from the thermosensor. The PID controller runs on a separate microcontroller (Atmel ATmega8). The CPU reads the other sensory data as joystick, rotary encoder, the rest position switch and the camera sensors. It communicates to the keyboard (which is based on another Atmel microcontroller) as well. It can be programmed and debugged via a JTAG interface and connects to a personal computer via a USB interface.

### 4.2.4 STIMULUS GENERATION

Except comb vibrations, all known stimuli in the honeybee dance can be reproduced by the robot.

- 1) **Signals originating from wing oscillations:** I tested different kinds of actuators for the generation of wing oscillations: a custom-made solenoid, a tiny DC motor and a loudspeaker. Being a little bulky, the speakers are found to meet best the requirements in frequency and amplitude. The solenoid can be oscillated at all feasible frequencies and is less heavy than the speaker but cannot produce amplitudes of 0.2 mm (peak to

peak displacement of the wing tips). The small DC motor, used in mobile phones for the vibration alarm, can produce big amplitudes and is the smallest actuator but cannot reach frequencies of over 260 Hz (target frequency: 280 Hz - 320 Hz). Hence, the loudspeaker is used for the final version. Refer to Figure 39 for images of different wing driving mechanisms.

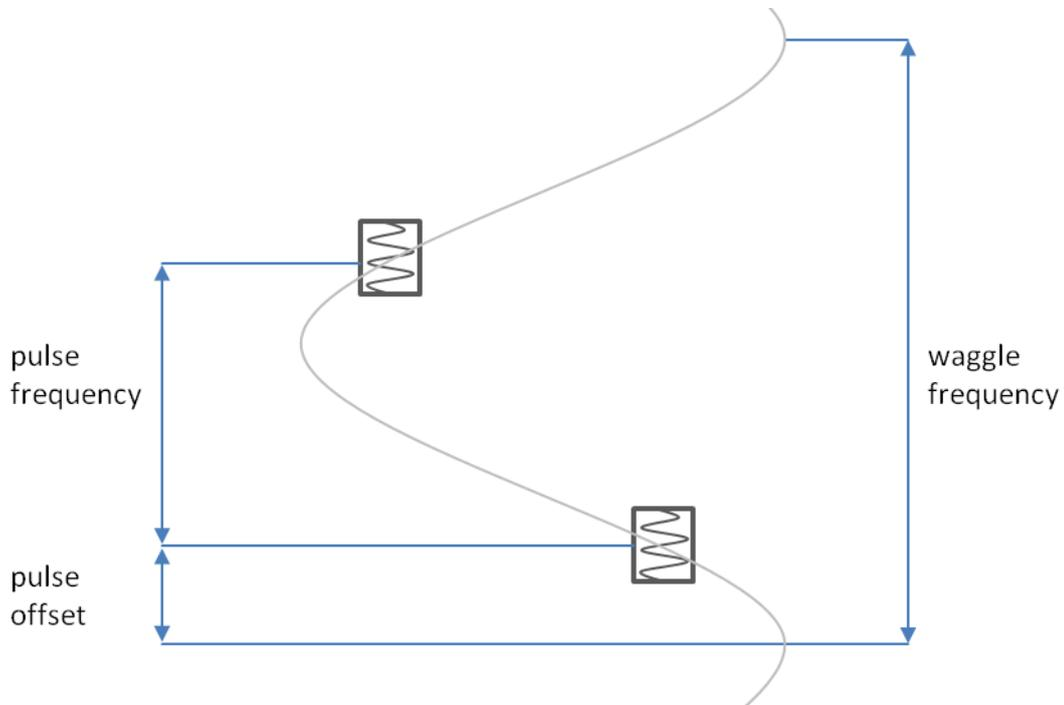

Figure 37: The scheme above depicts the how two of the four parameters that define the robot's wing oscillations determine the temporal dependency to the waggle oscillation. Each pulse can be shaped by setting the parameters "carrier frequency" and "pulse duration". The former is set to a value typically around 300 Hz. The pulses are periodically repeated, determined by the "pulse frequency". Using this parameter, the pulses can be synchronized to the waggle oscillation. By increasing the "pulse offset" each pulse can be shifted in time to be localized at certain locations on the waggle sine (depicted in gray).

The robot's firmware implements a parametric model for the wing pulse generation. Four parameters have to be set: *carrier frequency*, *pulse offset*, *pulse frequency* and *pulse duration*. All parameters are described in Figure 38. With these four parameters the experimenter is able to freely set a variety of different wing pulse behaviors, e.g. it is possible to synchronize the wing oscillations with the waggle oscillation. Therefore, the *pulse frequency* can be set equal to the waggle frequency and the pulses' location on the waggle trajectory can be set freely using the *pulse offset* parameter.

The wings are responsible for producing four different kinds of (potentially meaningful) stimulation: short-ranged airflows at the rim of the wings, laminar airflows ("jet streams") that are pushed rearwards, mechanical cues upon touching and presumably electric fields. If the wings are used as described all stimuli are produced jointly.



Figure 38: Final wing mechanism. A carbon rod, driven by a loudspeaker, vibrates according to a parametrically adjustable function. The rod is connected to a metal rocker which is attached to a plastic wing. The wing therefor is moved radially, producing laminar airflows towards the abdomen.

In order to separate those stimuli it is necessary to change the setup. The electric field can be produced by plugging the wing driver into a pre-amplifier that adds a certain amount of DC voltage to the signal. The output of the pre-amp is then fed into a transformer that produces high voltages (of up to 100 V). This signal is then routed through a shielded cable which has the shield removed at the very end, close to the robot body. Measurements have shown that the electric field produced by the robot results in similar signal amplitudes when recorded with the same setup that was used in the original recordings with real bees. The test recordings were done by Andreas Kirbach and are described in (Kirbach, 2013).

Generating oscillating airflows uncoupled from continuous streams (“jets”) is not possible anymore. By adding the plastic cover sheet the wings are restricted to be driven with the rocker mechanism that produces a radial motion of the wings only.

The wing buzzes in natural dances are typically accompanied by thorax vibrations. It is also possible to connect the thin carbon rod to the body only, so the whole replica is vibrating (without the wing beats).

- 2) **Trophallaxis:** The trophallaxis motor squeezes little drops of sugar water out of a flexible canula. It can be used to present food sample drops of  $\sim 0.2 \text{ mm}^3$  size at the robot’s head. This is done in the waggle mode of the robot after a variable number of waggle runs, or triggered manually using the remote control. The robot is stopped and a drop is presented to the follower bees. After a definable number of seconds the dance is continued. This behavior can be overridden in favor of manual control.
- 3) **Heat:** The thorax part of the bee body can be heated up to  $42 \text{ }^\circ\text{C}$  and maintained using a proportional derivative (PD) controller. The current temperature is read out from a thermosensor packed together with the heating resistors into the thorax of RoboBee. According to this measurement (and its relation to the target temperature) and the change of this measurement a unit duration (1 ms – 10 ms) of constant voltage is applied to the circuit.
- 4) **Scents / Semiochemicals:** The replica should carry a number of chemicals for camouflage (the hive’s scent), a potential dance-specific signal (the “waggle scent”) and the presentation of associative, food-related cues (pollen or nectar scents). Before the robot can be put in the hive it is advisable to coat it with wax from the colony. Therefore a small amount of wax (removed from the comb) is solved in hexane. All robot parts that are exposed to the comb side are covered with this solution. After half an hour most of the hexane has evaporated and a thin wax coat remains. The wax layer (re-)acquires quickly any chemicals that did not solve when put into the hive for a few hours prior to the experiments. The “waggle scent”, a waxy mixture of four different long-chained carbohydrates, is simply painted onto the replica using a “Q-tip”. The nectar scent maybe mixed with the sugar solution or similarly smeared onto the robot body.

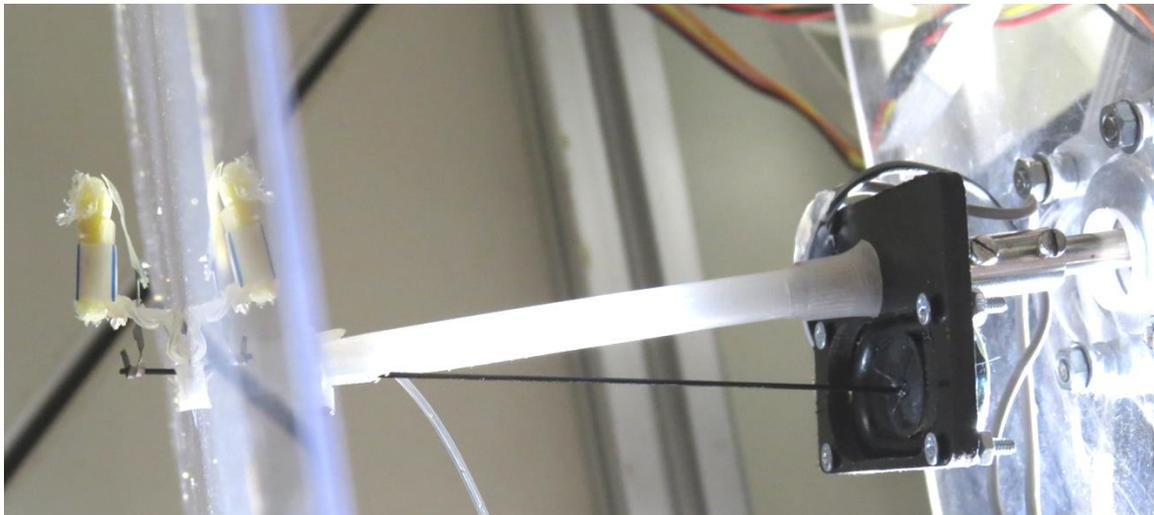
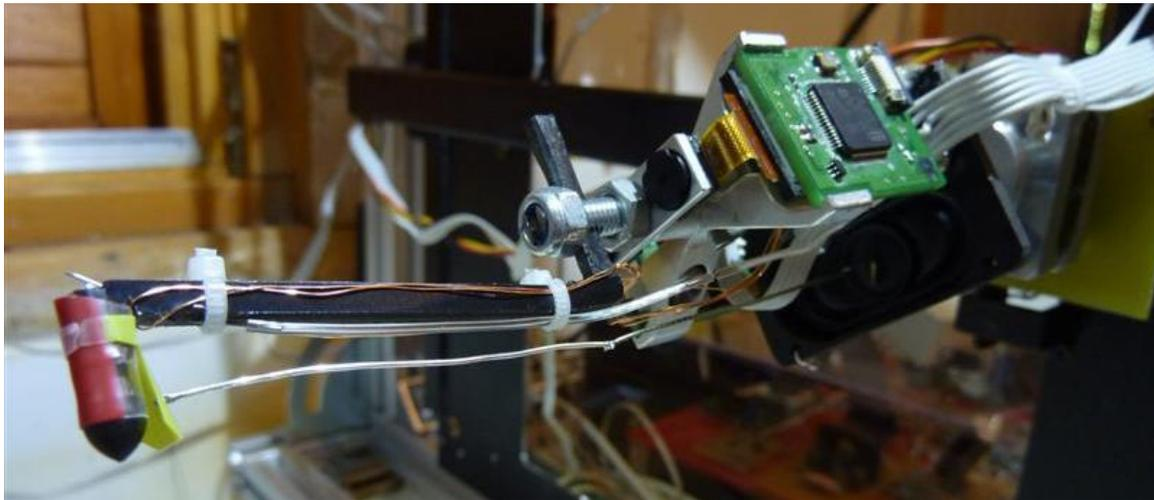
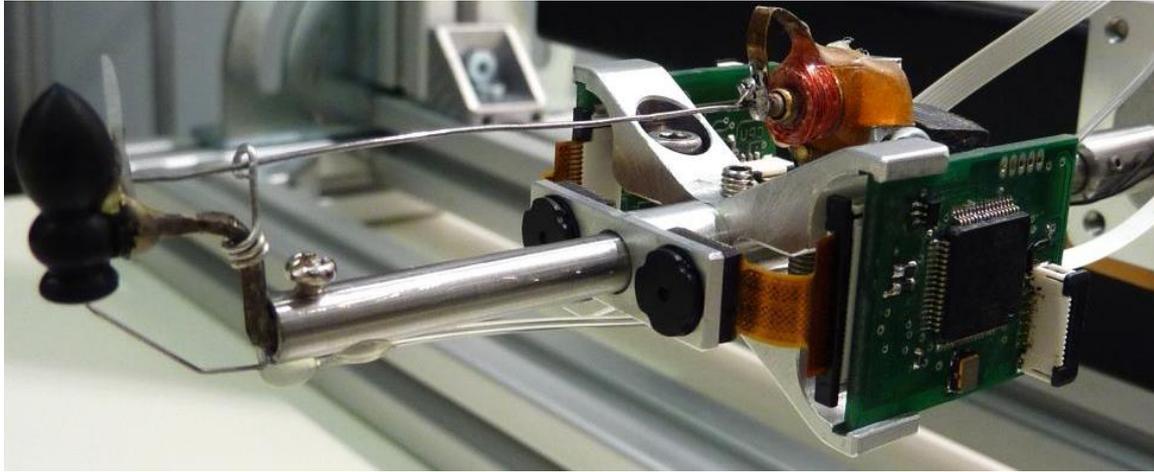

Figure 39: The central rod connects to the orientation motor and carries varying equipment. The wings are driven using a loudspeaker that is fixed to the main axis of the robot (black part in the right of the image). Its vibrations are transmitted by a stiff wire (top and middle photograph), or a carbon rod (bottom image). The replicas can be made from a single material (PVC in the top image) or a few components. The most complex replica is shown in the middle picture. It integrates a thermosensor and two resistors used to heat up the body. The abdomen is made from PVC. Those components are held together by a plastic tube that is stuck on a small L-shaped notch at the end of the black plastic arm. The wings are made from the same material, cut out a drinking straw. The replica in the bottom photograph has a soft core made of a rinse sponge. The sponge is wrapped in plastic foil to seal the scent. This model holds a seesaw mechanism that connects on the one side to the carbon rod and on the other to the artificial plastic wing. The seesaw results in a larger amplitude of the wing oscillation. The latter two versions provide sugar samples through a syringe tip (center image) and a flexible tube (bottom).

#### 4.2.5 CENTRAL ROD AND BODY DESIGN

Throughout the years we tested numerous types of replica materials and components. Supported by experimental evidence (described in Chapter 5: Experiments), we chose the final replica body to be made of a soft sponge wrapped in plastic foil. Some examples are shown and explained in Figure 39 and Figure 40. Also the central rod was changed due to biological guidelines or design specifications. The use of metal near the replica e.g. was discouraged because it might change the shape and strength of electric fields. The final design consists of a short threaded metal rod that holds the loudspeaker and a hollow plastic tube through which the carbon rod is led that transmits the vibrations to the wings (see Figure 39 – bottom image).

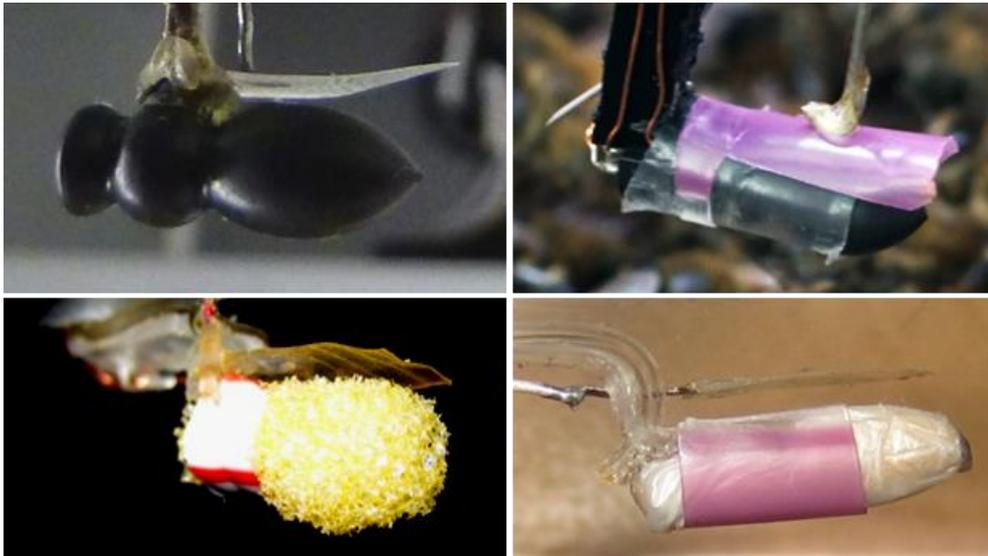

Figure 40: Many replicas have been tested. The initial model was made from PVC but turned out to be too hard. Flexible materials were tested (such as a sponge, lower left image) and a body heating was constructed. The final model is made from a sponge and plastic foil. This combination of materials offers a passive compliance when touching the comb surface or other bees. The “chemical camouflage” of the models is described in Chapter 5.

#### 4.2.6 VISUAL OBSTACLE RECOGNITION

Running into or over potential followers is not advised. In order to avoid aggression resulting from improper robotic behavior camera modules were developed for the detection of obstacles. This system has to detect fast movements, with a very low latency to enable the robot to immediately react on imminent collisions. To simplify and speed up the recognition two techniques were used: Firstly, the cameras are moved with the robot, such that the body of the replica occupies always the same pixels in the camera image (see page 82) and secondly, we lighten the back of the dance floor with red light (720 nm wavelength) using an LED array. Bees standing on the comb can be recognized in the camera image by the shadow they cast. By defining pixel patches (sensor regions of interest, so called “SROIs”) the evaluation of whether the robot is close to an obstacle can be done at the sensor’s frame rate with practically no delay. The modules’ response can be encoded in only a few bytes. The processing pipeline hence is structurally minimized for highest speed.

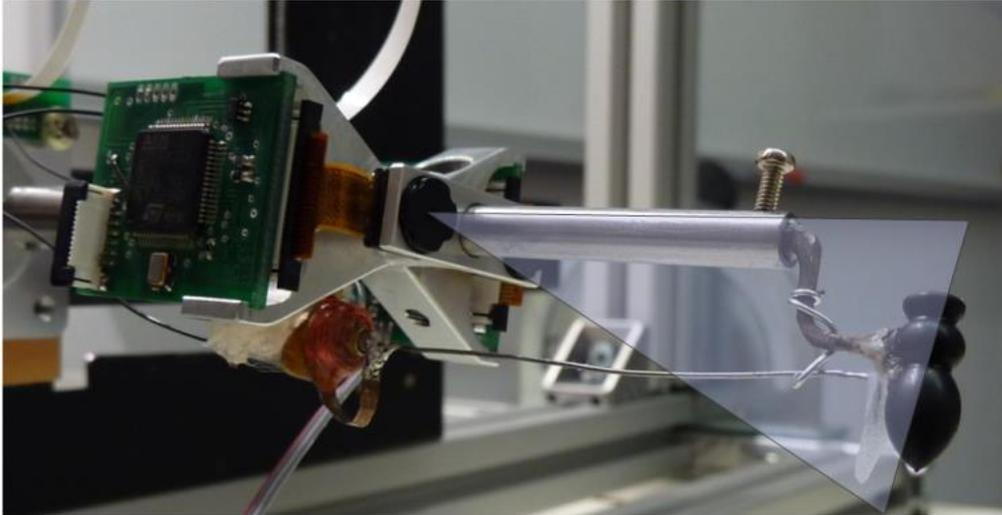

Figure 41: Two small circuit boards, fitted to the central rod of the robot, are integrating a CMOS sensor and a processing unit. The image sensors are aligned orthogonally to the central axis such that a region around the bee replica can be observed.

We developed two prototypes. The first prototype was based on an existing hardware system (HaViMo) originating from the robotic soccer team of the Free University Berlin and was programmed by Daniel Rhiel in the context of his Bachelor's thesis. The second prototype was based on a faster processor and was designed and built by Michael Oertel. In the following I give a short overview of only the second prototype. The interested readers are referred to Rhiel (2009), (Landgraf, et al., 2010) and (Landgraf, et al., 2012).

### CAMERA HARDWARE DESIGN

The modules are based on an ARM Cortex M3 microprocessor. All object recognition tasks are done on this controller. The results are reported back to the main processor of the robot via a serial connection. Image regions of only 80 px by 30 px size are evaluated per frame. Seven so called Sensor Regions of Interest (SROIs) can be defined dynamically inside this ROI using the software described below.

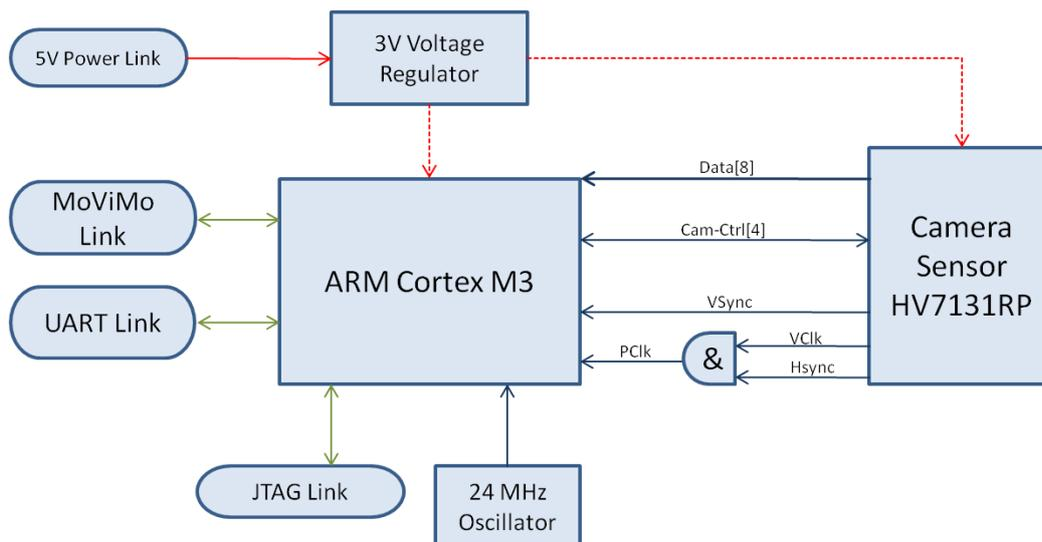

Figure 42: Schematics of the hardware of the second obstacle recognition prototype. As the central processing unit, we use an ARM-compatible Cortex M3 processor. One module serves as the connection link to the main board of the robot (UART Link) and connects also to the second module via a serial interface (MoViMo Link). The camera sensor delivers 8 bits in parallel for the image data and exports four channels for the configuration of its registers. The VSync signal encodes the beginning of the new frame and the VClk and HSync signals are integrated to obtain the Pixel clock (PClk). The camera can be driven using an external clock (24 MHz maximum).

## **CAMERA FIRMWARE AND OBSTACLE AVOIDANCE**

The software for the modules consists of a communication layer which is used to send and receive packages to and from the main board and the personal computer. The actual computer vision is done in a single main loop in which each pixel is read out of the internal memory. The processor's DMA writes new pixel data into this memory location every time the PClk line signals availability of new data. In the main loop each new pixel is assigned to a "super-pixel", i.e. a pixel that covers the area of  $4 \times 4 = 16$  pixels and integrates the brightness values of them. Each "super-pixel" is binarized by comparing its brightness to a threshold value. Rudimentary morphological operations are implemented to filter out noise. E.g. if a super-pixel has no neighbors, it is deleted. Each byte sent to the main processor of RoboBee contains the binary value of 8 super-pixels. This "obstacle map" contains  $35 \times 20$  pixels and is used as a look-up table in the main program. If, for a certain motion, this map contains obstacle, the motion is slowed down. Secondly, we developed an online blob construction method that a) creates blobs (binary large objects, i.e. connected pixels) and b) recognizes if their shape is ellipsoid and c) computes their location and orientation. If, after a complete frame has been processed, a newly found ellipsoid blob is located near the abdomen and the ellipse points towards the abdomen, the waggle amplitude is lowered by a certain fraction. If the blob is located near the head, the dance is stopped and trophallaxis is initiated.

## **VALIDATION AND RESULTS**

We tested the system with live bees in 2010. The hive was setup as described in Chapter 3: Observation Hives and Maintenance. Depending on the light conditions the system reaches frame rates of up to 120 fps. Severe collisions in the return run are avoided with this system. The behavior that was implemented did not alter the dance shape, i.e. there are no evasive maneuvers initiated; only the motion speeds are multiplied by some fraction of 1. This decreases the impact energy and we observe less aggressive behavior towards the robot.

The obstacle avoidance during the waggle run did not always work since fast waggle movements produce motion blur. In order to avoid this, a high lighting intensity is required.

The recognition of bees that might be interested in sugar samples cannot be solely done by evaluating their body posture. The trophallaxis program was initiated too often. We tried to decrease the frequency with which the system delivers sugar samples upon the visual sensory input. This resulted in a static stop-and-go behavior. The robot seemingly recognized food sample situations continuously and stopped right after the no-reward duration expired. Bees did lick the sugar from the robot, but this reflected their recognition of the sugar rather than the robot's recognition of the readiness of the bees to receive food samples. An experienced bee observer can recognize this readiness by evaluating the follower's behavior, including antennal movements and their tendency to move and stay at the head of the robot.

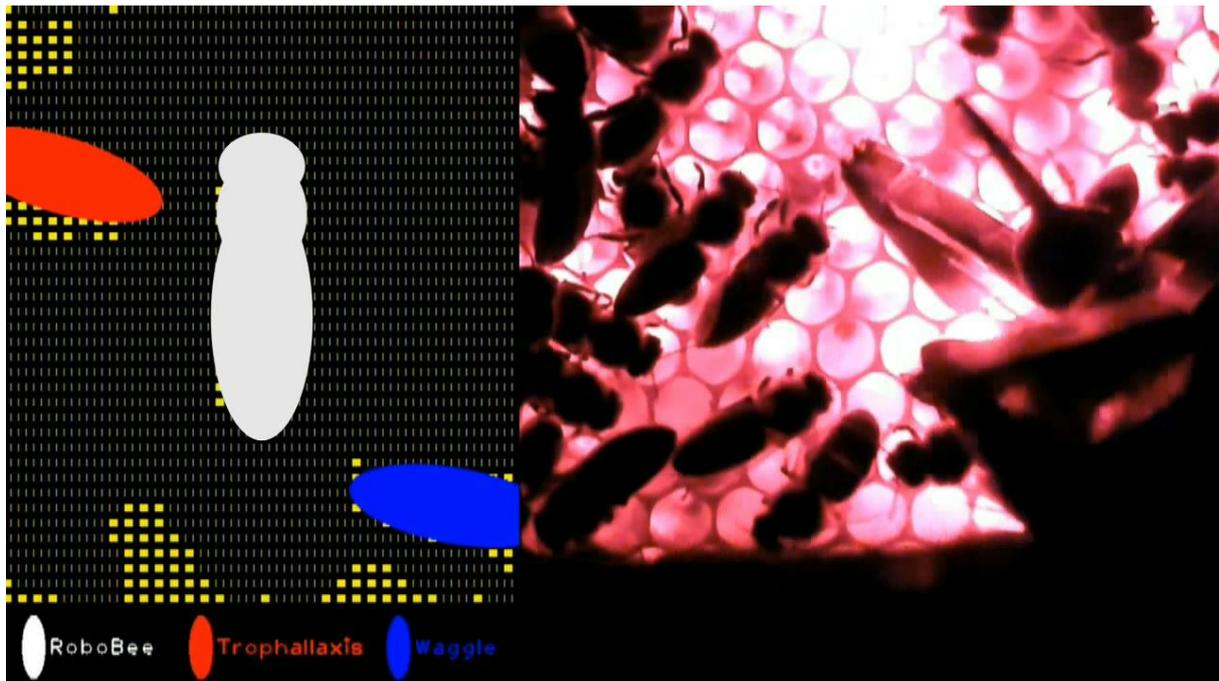

Figure 43: The figure depicts all levels of information extraction in the visual processing structure of RoboBee. In the right part of the collage RoboBee is shown while dancing. Two bees are approaching her from the left part of the head and another bee (only her abdomen is visible) approaches the robot from the right side of the abdomen. The left part of the figure shows the sensory processing stages. In the center, plotted with grey ellipses, the position and perimeter of the bee replica is depicted. Yellow squares display the obstacle map, i.e. at this location the vision modules sensed a bee. The main board of RoboBee takes this obstacle map as input and calculates the location and orientation of ellipse-like structures. Two of those structures were found: one, colored red, and one colored blue. The red ellipse is recognized as a bee that is likely to approach the robot for a food exchange (trophallaxis) and the blue blob is likely to be a bee that is decoding the waggle run.

### EMBODIMENT INTO THE SYSTEM

The cameras are connected to the main controller and to a USB interface board that connects to the personal computer. The latter connection is used to receive an image stream, sensory data and to write camera registers for calibration purposes. All sensory data is sent to the robot's main controller via the UART interface. The robot can be used without any connection to a personal computer by using default values for the parameters, such as the binarization thresholds, SROI positions, etc.

### 4.2.7 GRAPHICAL USER INTERFACE

The robot can be configured using a graphical user interface running on a personal computer. The program was written in C++ using Qt and OpenCV. It partitions all tasks necessary in tabs.

#### LOCATION MANAGEMENT TAB

The first tab contains a graphical representation of important field sites, in a relative coordinate system centered at the experimental hive. All feeding stations, or other points of interest can be set using XML files. The user can select certain locations or simply drag the target location with the mouse. The azimuth angle of the sun is calculated depending on the (current or other given) date and time and displayed on the map. After setting or selecting a location, the distance and angle with respect to the sun is computed and sent to the waggle dance model

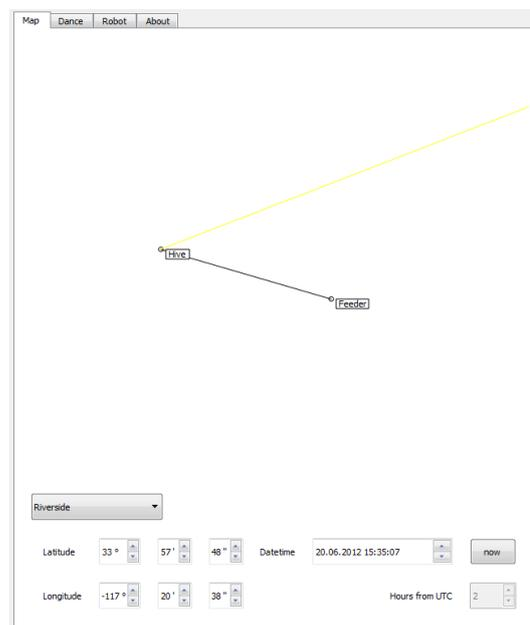

tab.

### WAGGLE DANCE MODEL TAB

According to a set of parameters (described in Chapter 3: Analysis of the Dance) the shape of the dance can be altered and displayed in the waggle dance model tab. The parameters can be saved to and loaded from a file and eventually uploaded to the robot. The tab shows the path of the replica in blue color and the path of the plotter's central axis in grey. The number of waggle cycles to be displayed can be adjusted to check if the parameters result in a dance on-the-spot or if it gradually leaves the dance floor. Also, the eccentricity of the replica (i.e. the distance from the central rod to the center of the replica body) must be set according to the actual model used. Once the dance is defined on the robot it can be started on the robot control tab.

### ROBOT CONTROL TAB

This tab provides a number of buttons and widgets for the control of the robot. Each motor can be switched on or off, the orientation motor can be turned to its zero-degree position. The dance can be started and stopped, or paused and resumed. The robot can be driven "down", i.e. the carriage is moved to the resting position. Using the mouse, the robot can be moved and turned continuously, e.g. to move to a certain spot on the dancefloor. E.g. by dragging the mouse while the left mouse button is pressed, the robot moves in the hive plane, while moving the mouse up and down with the right mouse button pressed rotates the replica. The other actuators for the wing oscillations, the heating or the trophallaxis can be configured and tested on this page as well. All parameters can be set and are uploaded once the stimulus is enabled for the dance. Manual control of the robot can be exercised in three modes: the GUI mode, the keyboard mode and the joystick mode. The first mode restricts the user to start, pause, resume or stop the dance and rely on the vision sensors alone to brake or stop the dance. The keyboard and joystick modes are designed to control the dance in a semi-automatic fashion.

### SENSOR CAMERA TAB

The sensor cams can be configured and tested using this tab. All camera registers, e.g. for controlling the exposure time or gain factors, can be edited and written to the cameras. An image of each camera can be downloaded to the GUI. Using mouse interactions the user can define the location of the replica in the image and the sensory area around it.

## 4.2.8 IMPLEMENTATION OF THE DANCE MODEL

The model described in Chapter 3 was implemented in C on the ARM platform that makes up the robot's core processor. The model is evaluated every millisecond and each time  $t_i$  a new motor velocity vector  $v = (v_x, v_y, v_a)$

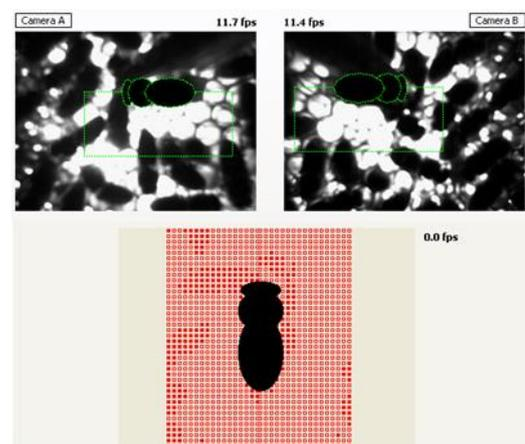
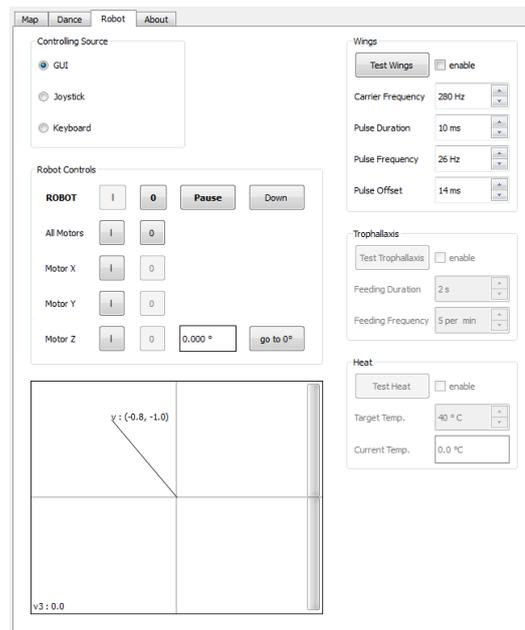
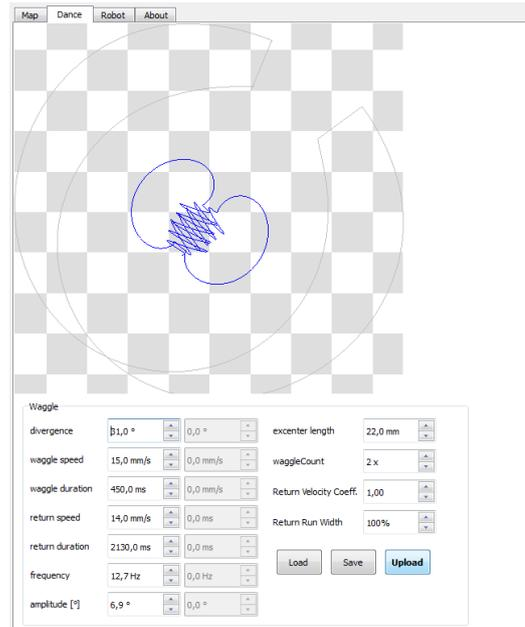

is computed and executed by the motors. The dance model is divided into the waggle portion and the return run. In the former, the computation comprises the following steps:

- Prior to the actual waggle, the body is turned into the appropriate direction (correcting for a possible angular error).
- The body is then moved forward, according to the parameter *waggle forward velocity*.
- The waggle oscillation is produced by a sine wave (whose amplitude is defined by the parameter *waggle amplitude*) executed by the orientation motor only. Within the first and last 10 milliseconds, the sine wave is linearly faded in and out, respectively.

The return run is produced similarly in two general steps:

- A velocity vector for the three body axes of the replica is produced, following the functions *return forward velocity*, *return sideward velocity* and *return angular velocity*.
- The relative vector is rotated according to the body orientation. The resulting vector corresponds to the plotter's coordinate system.

The return velocity functions are given in a polynomial form. The number of time steps is still variable and the angular velocities drawn from the function might not add to a full turn in the return run. Hence, after each new configuration a normalization constant is computed to make sure the replicas orientation after the return run is close to the expected full turn (minus the divergence angle).

Two additional convenience parameters have been added to the dance model to alter the shape of the resulting trajectory in the return run. The parameter *return velocity coefficient* controls the forward and sideward velocities. It corresponds to a scalar weight which is multiplied with both the *return forward velocity function* and the *return sideward velocity function*. The parameter hence can be used to up- or downscale the return run.

The parameter *return run width* corresponds to the shape of a quadratic weighting function for the *return angular velocity function*. Low values for the parameter result in emphasizing the middle part and dampening start and end turning velocities. This results in a "flat" return run, with straight middle parts. Increasing the *return run width* flattens the quadratic weighing function and leaves the turning velocity unchanged.

#### **4.2.9 MOTION CONTROL AND BEHAVIORS**

The robot offers three control modes:

##### **Automatic control using camera feedback**

The automatic mode follows the dance model but interrupts the execution when a) an obstacle in sensory regions at the head (while in the return run) or at the sides (while in waggle mode) or b) a potential follower in trophallaxis position are sensed (see above).

##### **Semi-automatic control allowing manual control via keyboard or joystick**

The keyboard mode enables the experimenter to steer the robot along the plotter's axes. The replica can be positioned anywhere on the comb and rotated. The velocity of those movements can be selected by a dial on the keyboard. The keyboard can also be used to control the robot in the waggle phase. The dance model is executed as long as the "waggle button" is pressed and interrupted otherwise. While the dance is executed the inputs of the directional pad are added to the velocities of the dance model.

The joystick mode allows to control the robot relative to its coordinate system. Pushing the stick forward moves the replica into the direction it is headed. Deflecting the stick to the left or right turns the robot. Both axes can be mixed for describing an arc. The "fire button" triggers a waggle run as long as the button is pressed.

A second button is used to modify the left and right axis: if pressed, all deflections to the left or right are processed as sideward movements. A third button triggers the trophallaxis pump and a fourth button switches the motors off or on.

### Manual control for global positioning only

For the sake of completeness the graphical user interface offers a control mode as well. The experimenter can click and drag the mouse within a coordinate system. The vector from the coordinate system's origin to the mouse cursor's location is proportionally translated for planar movement of the robot. Turning of the robot can be accomplished by pressing the right mouse button and dragging the mouse up or down.

## 4.3 VALIDATING ROBEBEE

In this section I describe how the parts of the system are validated.

### 4.3.1 MOTION PRECISION

There is always a certain difference of the output of the dance model and the actual output of the mechanical system. Measurement errors of system dimensions, faulty model assumptions and mechanical noise from various sources have an influence of this difference. In order to estimate how severe the influence of those factors is, I recorded and traced the motion of the replica and compared it to the model output.

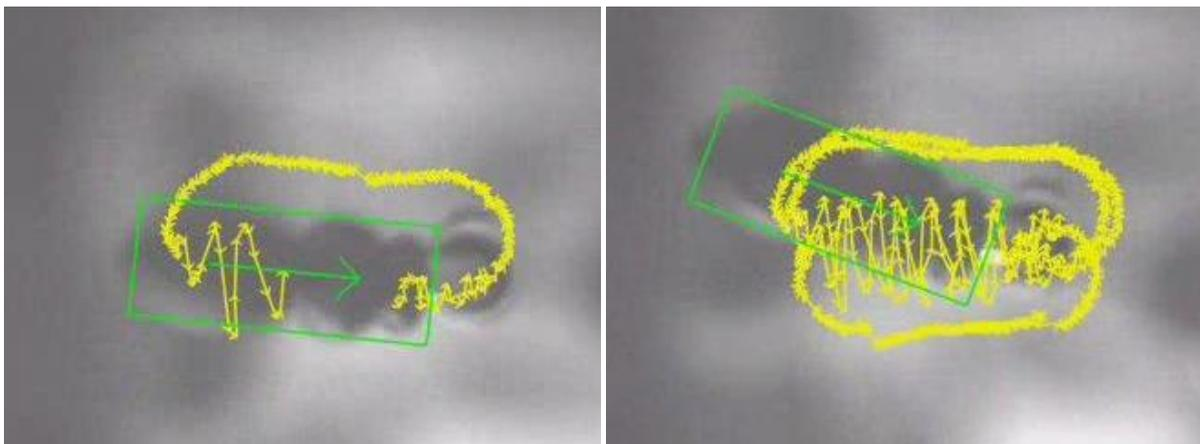

Figure 44: This figure shows two screenshots of a robotic dance video recording. The path of the robot was traced with a tracking program and visualized on the video. The green box displays the current position of the robot, the yellow lines connect the history of body center positions.

The dance model implemented on the robot produces velocities for the three motors. These velocities need to be integrated to obtain a reference trajectory. It is foreseeable that the error in position accumulates if the robot does not translate all target velocities right. Hence, for long trajectories one would expect increasing positional errors. In the model I assume infinite acceleration, which cannot be reproduced by the real world system. High accelerations inevitably introduce a lag in comparison to the model. However, for the dance communication I require the shape and the timing of the dance trajectory to be sufficiently similar to the model for one dance cycle only. The analysis thus only compares trajectories of single cycles to the model reference.

## RESULTS

The comparison of the robotic tracks with the assumed model positions reveals a maximum error of 1.2 mm at points with high accelerations, i.e. within the waggle phase and right after it. The angular error is corrected for prior to every waggle run using the rotary encoder. This might take up to 20 ms and therefore introduces a temporal error with respect to the model.

Additional load on the central rod might amplify the error. The system is prone to mechanical noise with increasing load, especially in high phases of accelerations. However, the plastic sheet that has mechanical contact to the hive glass dampens this noise. Periodic vibrations might vanish but a substantial lag – similar to a smoothing – might be introduced to the position of the robot. This lag depends on some controllable factors and some in practice hardly controllable ones. The stiffness of the carriage (which holds the rotation motor, the central rod and the four holders with the transparent plastic plate) might decrease over time due to one locking screw on the carriage that eventually might loosen. Prior to every experiment, I control the mechanical running smoothness of the carriage and the tightness of all screws. Hence a high stiffness can be assumed for all tests. Given that, a second variable is the pressure with which the plastic sheet is pressed against the hive. Since the four pistons are pushing outwards with the force of the integrated springs the maximum force depends on and is limited by the springs. Depending on the maximum torque of the motors (a function of the supply voltage) the carriage might get stuck and the motors “lose steps”, meaning that although the motor drivers give correct input frequencies the motors produce no motion at all; plus a high pitched tone. This might result in a serious crash, because the carriage cannot be held in position on the vertical axis as well. I selected spring constants such that even with full pressure to the hive window the motors should be able to move the carriage. Since the plastic plate might be exposed to the inside of the hive for a substantial amount of time it might accumulate wax chunks that increase the friction on the glass. Adding to this, the rim of the window aperture is laid out with propolis and wax by the bees continuously. Under laboratory conditions these factors might be disregarded. Under experimental conditions this is a serious source of malfunctions. Excluding those “catastrophic” situations, the robot’s movements have a very low error in position and a low error in timing under normal conditions. Working in a real world environment this error might be a bit larger due to changing loads and coupling forces of cover sheet and hive glass or due to temporal scatter when the robot is controlled manually.

It seems safe to assume that honeybees are able to cope with a far higher amount of variability. There is no information about how noisy the motion of the robot can be though (or possibly has to be). Real dance trajectories have large deviations from the mean position of up to a few centimeters, an angular standard deviation of around 30 degrees and temporal deviations in the order of seconds: The error of the robotic system is extremely low (up to three orders of magnitude).

#### **4.3.2 FUNCTION OF THE WINGS**

The robot’s wing is a special actuator: it is supposed to produce oscillating airflows, laminar “jet streams” and electric fields. The first validation was performed visually to confirm each pulse is actually executed by the wing. Only the loudspeaker (as opposed to a vibration motor and a custom made solenoid) and the rocker mechanism realized the correct sequence of wing beats per pulse. Although the driving signal is rectangular the resulting wing motion is smooth due to the mechanical components between signal generator and (flexible) wing plate. A video recorded at over 600 fps of the wing motion is available in the dissertation repository at [www.robobee.eu/dissertation/landgraf](http://www.robobee.eu/dissertation/landgraf).

In order to gauge the shape and strength of the laminar air flow, a custom anemometer was built. It consists of a heating resistor, a thermistor and an operational amplifier. The circuit is described in Figure 45. The heat produced by the resistor increases the thermistor’s resistance and in effect changes the amplification of a constant input voltage. If a sufficient airflow is produced by the wings a part of the heat is carried away. This results in a decreasing resistance of the thermistor. Thus, the input to the amplifier is increased and so is the amplification level. Using an AD converter (CED MICRO 1401 mkII) this output voltage is recorded over time and across varying position by means of a micromanipulator. For a set of sampling points behind the bee replica the difference of the output voltage with wing movements to the output when inoperative at a constant room temperature (23 °C) was measured. Because a feasible calibration method is lacking, we cannot convert this information into the actual amount of air that is moved. However, the relative magnitude of the airflow can be measured and moreover we are able to learn about the length of the jet streams that typically reach distances of 10 mm. Figure 46 shows a false color coded intensity plot of the air motion around the robot body.

Each sphere depicts a sample point. Its radius and color code the intensity of airflow measured. The jet is notably narrow in width but exhibits detectable intensities of airflow from the floor level up to 8 mm above the wings, typically the height where the glass window is positioned. This matches previous observations of jetstreams produced natural dances (Michelsen, 2003).

The production of dynamic electric fields by the wing plate was measured by my colleague Andreas Kirbach and is described in detail in (Kirbach, 2013). Depending on the level of static charge of the wing the electric fields closely resemble those measured in natural dances in shape and intensity. To my knowledge, those measurements have not been repeated with wax coated wings as used in the final prototype. If those wings produce similar fields thus remains unknown.

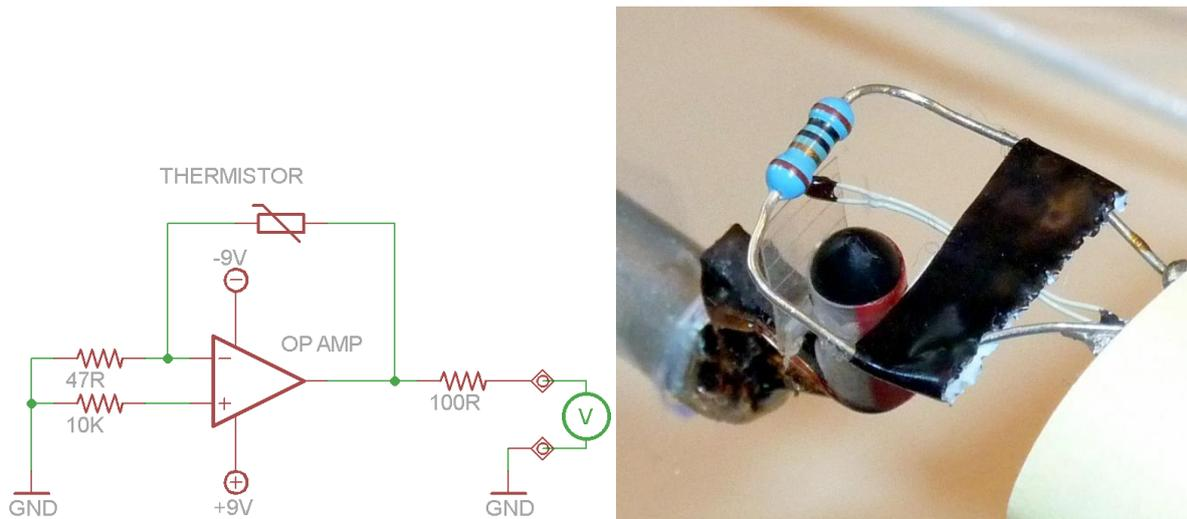

Figure 45: Wiring diagram of the circuit used to measure airflows produced by the wings of the robot. We use a trait of operational amplifiers producing a small “leak” voltage (a few mV) even though no input voltage is given. We feed back the offset voltage into the amplifier over a thermo-resistor. The amplification of the OP AMP is determined by the ratio of the two resistances to the left. Right: The thermo-resistor is positioned near the wing tips coupled to a heating resistor 1 mm on top of it. Figures published in (Landgraf, et al., 2012).

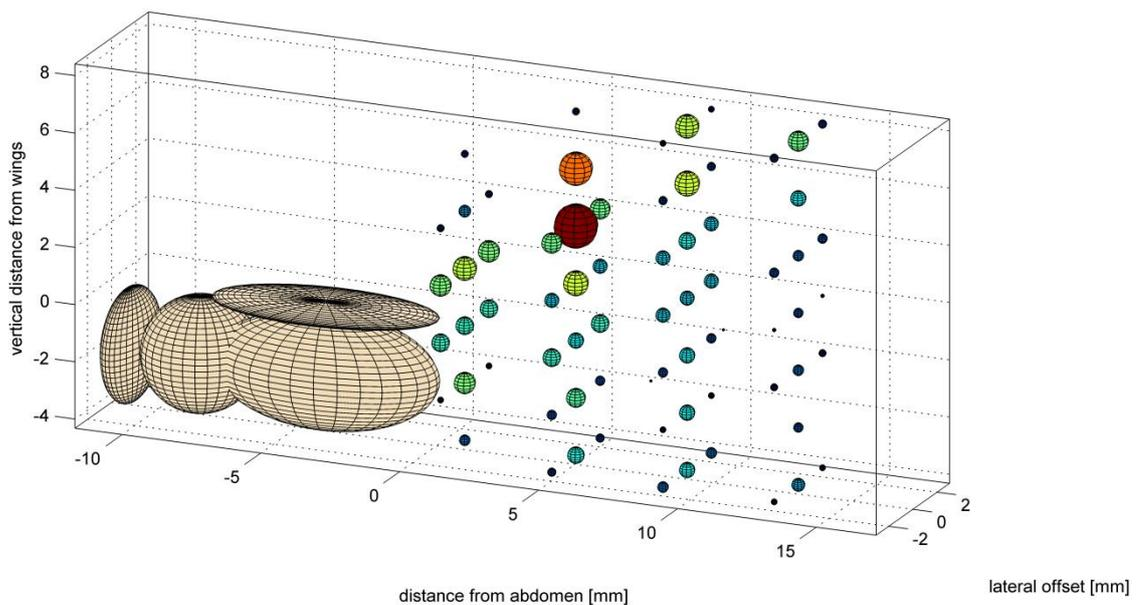

Figure 46: We have sampled the intensity of airflows for points at distances of 1mm, 5mm, 9mm and 13mm for various heights and lateral displacements. Along the dorso-ventral axis the “jet” is broad and would reach the glass cover over the comb surface. Laterally the jet is very sharp – it stays in the limits of approximately 4 mm, i.e. the width of the wing. Figure published in (Landgraf, et al., 2012).

### 4.3.3 HEAT PRODUCTION

The thermosensor used for the control of the thorax heating is calibrated as factory default. I measured the temperature at the thorax hull of the replica for temperatures from 35° C to 42° C, which was around 1° C lower than the sensor's result. This offset was implemented in the controller to obtain higher core temperatures but hull temperatures as set by the experimenter.

### 4.3.4 TROPHALLAXIS

The trophallaxis pump was validated optically as shown in Figure 47. The size of the resulting drop generally depends on the duration the pump is activated but varies because of air enclosed in the flexible tube. Prior to every experiment the tube should be filled with a full column of sugar water. The tube is very tight and might get clogged with crystallized sugar it is thus imperative to clean the tube after every experiment. The tube should be replaced regularly to prevent mold to be pushed to the bees.

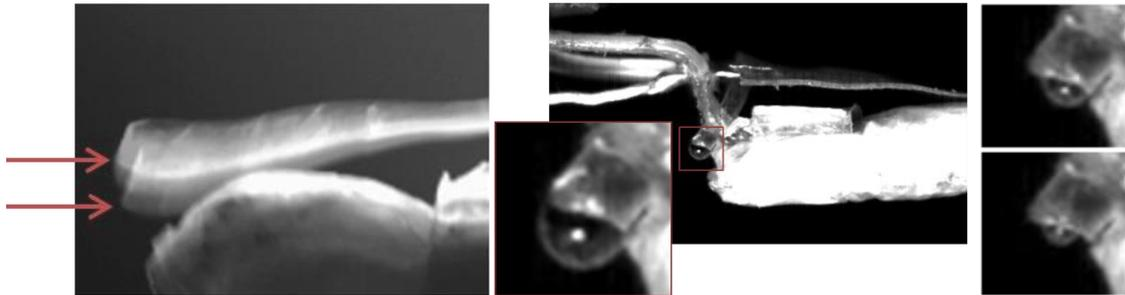

Figure 47: To characterize the wing oscillations, I recorded a short video (120 pixels x 160 pixels, 635 fps). Two frames showing the maximal deflections were superimposed in the left image. The arrows mark the wing tip at both extremal positions. The amplitude is approximately 1.2 mm. The body (under the wing) in the blended image is slightly blurred indicating that it vibrates as well. In the center image the tip of the flexible tube that delivers sugar water drops is shown. The maximum size of the drop is approximately 0.5 mm. Large drops are likely to fall off the robot though. Smaller drop sizes are shown in the two rightmost photos.

## 4.4 CONCLUSIONS

The proposed honeybee robot was developed in iterations over the course of 4 years. The first part of this chapter describes the mechanics, electronics, sensors, actuators, software and periphery of the final system. The robot is able to move over the entire comb surface, can deliver drops of sucrose solution, can be heated up, can flap its wing and uses a visual obstacle recognition unit to evade obstacles. The robot can be controlled by the experimenter with a simple keyboard, a joystick or mouse inputs. The motion of the replica and the stimulus production can be customized parametrically to meet various conceptual and practical requirements in field tests.

The robot is validated in laboratory setups and I could show that all target properties have been met with respect to the reproduced motion and stimuli. The replica can be moved with very low error and vibrational noise. The integration into a real honeybee colony is easily done within seconds without much disturbance. This this date, RoboBee allows for the most complete and realistic imitation of the honeybee waggle dance ever reported.

In the following chapter I investigate the effect of robotic dances on the colony and its members. I describe experiments that address the questions whether the robotic dance is followed, whether it is accepted or attacked and whether bees that follow the dance actually fly out and visit the communicated location.



# ROBOBEE IN FIELD TRIALS

Experiments on Acceptance, Following Behavior and Recruitment

## **5.1 MATERIAL ACCEPTANCE TRIALS: SUMMER 2008**

The very first experimental trials within a honeybee colony were conducted in the summer of 2008. The robotic platform had not been finished by that time. The aim of the following experiments was to record behaviors of how honeybees respond to different materials the robot body would be composed of. Later, when the robot body would contain electronic and mechanical parts, it would be desirable to know which sorts of glue are chemically neutral to the bees and, since the robotic body likely would have to be heated, which glues would evaporate chemicals that lead to aversive behaviors in the hive. Furthermore, the robot's trophallaxis, i.e. the delivery of tiny amounts of sucrose in the dance, will eventually soak porous materials which might be hard to clean. Sugar might stay in or on the body and lead to proliferation of mold. One trial focused on the change of the rate of acceptance under continuous exposure to small amounts of scented and unscented sucrose solution.

### **5.1.1 EXPERIMENTAL DESIGN**

For these tests a common two frame observation hive was used. On the face that was recorded the glass was replaced by a transparent plastic plate in which a window of 15 cm by 15 cm was cut out. This window could be opened to insert a material sample on the terminal of a carbon stick. This was equipped with samples of wood, silicone and a few sorts of plastic, shaped as a bee sized ellipsoid. For the first trials (T1) no glue was used to affix the sample material to the rod. Video recordings were taken and analyzed afterwards. The recording and lighting equipment as described in Chapter 3 was used. The second trial (T2) focused on the use of different glues. On a transparent plastic plate three kinds of glue were spread over a surface area of 5 mm by 5 mm. Once the glue was hardened the plastic plate was put onto the window to the hive with the glue patches facing to the comb. The bees' behavior was recorded again. The third trial (T3) concerned the use of a heating in the robotic honeybee body. The heating apparatus is based on two resistors that are heated up by an electric current. A thermo sensor was used to regulate the temperature of the heating elements within the hive. A complete description of the electrical circuit is given in Chapter 4. The fourth trial (T4) tested the effect of peppermint scented and unscented sugar solution on different porous materials. Therefore the carbon rod held a small flexible tube that delivered 2M sucrose solution to one side of the material sample. It was inserted into the hive such that each drop could run down the body replica and get soaked into it. For five days the material was placed into the hive for 10 minutes each day. The material was washed with water after every trial.

Standard video recordings and behavioral transcripts were made. The effect of each treatment is measured relatively: the number of class 1, class 2 and class 3 actions are counted and compared to the average number of those observations among nest mates in the same recording. If the measured number exceeds the mean by two standard deviations the behaviors are considered to happen "more often" than naturally. Vice versa, behaviors

that were classified “less often” are defined as having a count that is less than the natural average minus two standard deviations.

The following body materials were used:

- White Silicone
- Sponge foam
- Beech Wood
- Polyethylene (PE)

The following types of glue were tested:

- UHU Alleskleber
- Pattex PK6ST (two component glue)
- Epoxy

I propose a three-fold partition of different types of reactions: clearly aversive behavior (class 1), neutral or positive reactions (class 2) and reactions that could be either way (class 3). I use this threefold partition for all classification tasks on interaction quality. Table 4 shows that many behaviors can display aversive reactions – those are typically easy to detect since they happen scarcely in the hive among nestmates. Only a few behaviors are neutral or positive. Those behaviors can be observed frequently and are thus a desirable form of interaction with the material samples. In this paradigm, joining neutral and positive behaviors results from a dilemma: it is unclear whether a bee behaves ignorant to a piece of material because it recognizes its harmlessness, accepting it as a natural part of the hive (living or nonliving) or, although she recognizes it as something alien, she does not react to it. Therefore the heading of this part might well be renamed to “ignorance trials”. By that time it was sufficient for me to filter out materials that were *per se* leading to aggressive behavior.

**Negative, aversive reactions  
(Class 1 events)**

Stinging  
 Dragging away  
 Nagging  
 Staying on top for a long time  
 Fast retreating on touching  
 Fast turnaround on touching

**Neutral or positive reactions  
(Class 2 events)**

Licking  
 Touching occasionally  
 Running over or around it

**Unclassified reactions  
(Class 3 Events)**

Repeated antennal touching  
 Grabbing shortly with the front legs

**Table 4: List of observed behaviors in Material Tests**

**5.1.2 RESULTS**

**Silicone** has advantageous properties as it can be shaped conveniently by using molds or a carving knife. It stays a little soft and thus might be absorbing energy in collisions. Though, its chemical properties are preventing it from being used in the hive. Silicon hardens out after drying for about a week. But still, the bees attacked this material heavier than all others. Most behaviors in T1 were Class 1 reactions. I found stings in the artificial body after taking it out and in the recordings I observed the bees trying to drag it away, nagging it continuously, staying on it for the entire duration of the trial. The number of class 1 events reduces when being put in the hive for a number of days prior to the test but still would not reach ignorance or acceptance.

The soft piece of **rinse sponge** has advantages in the dance. It might absorb the energy of collisions and thanks to its porous texture it may provide a familiar “feel” to follower bees. Though, inserting it led to constant nagging and dragging up to a level where the body shape changed significantly. In T4 the sucrose and peppermint oil first decreased the number of Class 1 events. Constant licking off the sugar could be observed. After 3 days the sugar might have altered the chemical structure of the plastic foam or mould might have grown in the cells of the sponge. In both the unscented and the peppermint scented trials the number of class 1 events was increased even higher than in T1.

**Wood** is a more neutral material: bees do touch it numerous but do not nag or sting it. It might exhibit an own scent which after keeping it in the hive might vanish. Its porous structure might lead to a fast dissemination of hive odors. In T1 wood is found to be as neutral as PE. In T4 the number of class 1 and class 3 reactions increased. The wood piece was touched more often and seldom nagged or dragged.

**Polyethylene** is found to be most neutral. The number of class 1 behaviors was lowest compared to all other materials. It also seems to acquire the hive scent as deducible from the reduction of class 3 behaviors. It can be washed and reused, especially after using it with additional scent.

T1	Silicone	Sponge	Wood	Plastic	T2	UHU	Pattex PK6ST	Epoxy	T3	UHU + PE	Pattex PK6ST	Epoxy	T4	Silicone	Sponge	Wood	Plastic	Silicone	Sponge	Wood	Plastic	
	C1	C2	C3	C1		C2	C3	C1		C2	C3	C1		C2	C3	C1	C2		C3	C1	C2	C3
	Dark	Dark	Light	Light		Dark	Dark	Light		Dark	Dark	Dark		Dark	Dark	Light	Light		Dark	Dark	Light	Light
	Light	Light	Light	Light		Light	Light	Light		Light	Light	Light		Light	Light	Light	Light		Light	Light	Light	Light
	Dark	Dark	Light	Light		Dark	Dark	Light		Dark	Dark	Dark		Dark	Dark	Light	Light		Dark	Dark	Light	Light
														1 <sup>st</sup> day					5 <sup>th</sup> day			
	comparably often					more often				less often												

**Table 5 1: Results of the acceptance trials.** Different materials and glues (columns of each matrix) were tested in different conditions (trials T1 to T4). The number of behaviors grouped in three classes (C1 to C3) were counted. The results are color-coded in each matrix cell. Dark cells correspond to conditions where corresponding behaviors were counted more than two standard deviations more frequently than in average. Light grey codes for a relatively low frequency (two SD lower than the average). Medium grey corresponds to values around the reference. Aggressive behaviors, i.e. class 1 behaviors (C1), were frequently observable with silicone and a raw plastic sponges (T1). Only epoxy turns out to be a neutral glue (T2), although heating leads to aggressive behaviors with all kinds of glue (T3). Sucrose solution on the material reduces aggressive behavior instantly (T4, left), but might alter the chemical composition of the sponge which gets attacked after 5 days of repeated sucrose exposure (T4, right).

### 5.1.3 DISCUSSION

Porous materials seem to acquire the hive scent faster but might be harder to wash. The sponge is soft and might dampen collisions but its chemical properties in trial 4 suggest that elongated exposure to sucrose solution alters its chemical properties. Polyethylene and wood seem to be relatively neutral but may be too hard when hitting bees. Silicone, even when seemingly hardened, must be excluded since it triggers many kinds of unwanted behaviors. Generally, the application of glue is disadvantageous. Only epoxy seems to be chemically neutral after it hardens. The results in trial 3, the test of acceptance under heat, show that all glues might evaporate chemicals when heated. However, the high number of aggressive behaviors might results from the heat source alone. In another test – this data hasn’t been integrated in the results above – I heated up a resistor inside the hive. The heat source gets inspected once it is inserted and the activity of the surrounding bees increases with increasing heat produced by the resistor. There is no (neutral) class 2 behavior observable after the resistor is heated above

40 degrees (the temperature of the thorax of dancing bees). Whether this is due to heat radiation or changing chemical properties of the resistor has not been investigated.

Hybrid bee replicas that exploit the chemical neutrality of PE and the physical softness of the sponge might be a solution. The number of “nagging and dragging” events is lowest for this combination of materials. The chemical fingerprint of the dummy can be altered by leaving it in the hive for a few days as described in the following section. However, it does not reduce nagging completely. Hence, any replica on the robot might eventually receive a marking with mandibular alarm pheromone (Shearer, et al., 1965) and should be replaced after a few experiments.

## 5.2 ACQUISITION OF THE HIVE’S SCENT

In order to quantify the effect of leaving the replicas in the hive an experiment was conducted. A number of replicas were built and attached to a ring-shaped stiff wire. Half of the replicas were left in the hive for two days prior to testing. Therefor a small cage was built into the hive to protect the replicas. The construction of the replicas involved applying a short burst of heat to the plastic foil to melt putative openings. This might destroy the foil and disrupt the surface resulting in the opposite: a *permeable* hull. In several trials two types of sponges were tested. After production of a replica each body was tested to be sealed by dipping it into water for a couple of minutes. If water had accumulated in the sponge (tested by squeezing it gently between filter paper) the plastic hull apparently was found permeable. Whether this has an effect on the behavior is subject to the test as well. Video recordings have been taken and the total duration of bees having longer contact (more than 3 seconds for each encounter) for each replica (and treatment) was noted. The experiments were conducted with the help of Philipp Norton.

### 5.2.1 RESULTS

The results are depicted in **Error! Reference source not found.**. Generally, bees inspected all replicas for a substantial amount of time. The lowest interest, i.e. inspection time, is observed with a replica built with a certain type of sponge material. It was sealed and acquired the hive scent before the test, resulting in less than 50% total inspection time. The second lowest inspection time corresponds to a replica built from the other sponge material – similarly this replica was sealed and exhibited the hive scent. Why the inspection time for this replica (~ 60%) is larger remains unknown. All other treatments, i.e. different materials and no hive scent result in longer total inspection times (70% - 80%).

### 5.2.2 DISCUSSION

The inspection time is a feasible measure for the interest of individuals towards sample material. The higher the inspection time the more likely the material is considered alien. Long inspection times (several seconds) among bees are not frequent although still possible. Other behaviors might be a better measure for acceptance. Nagging or dragging, as described above, are clear indicators of aversive reactions. However, one needs a clear view onto the tested material. Observing many samples at a time decreases the resolution per object and might render the resulting count erroneous. Nagging leaves mandibular alarm pheromone on the sample and therefore might give a positive feedback resulting in even longer inspection times. The hive scent treated samples are not nagged and are observed to generate the lowest inspection interest.

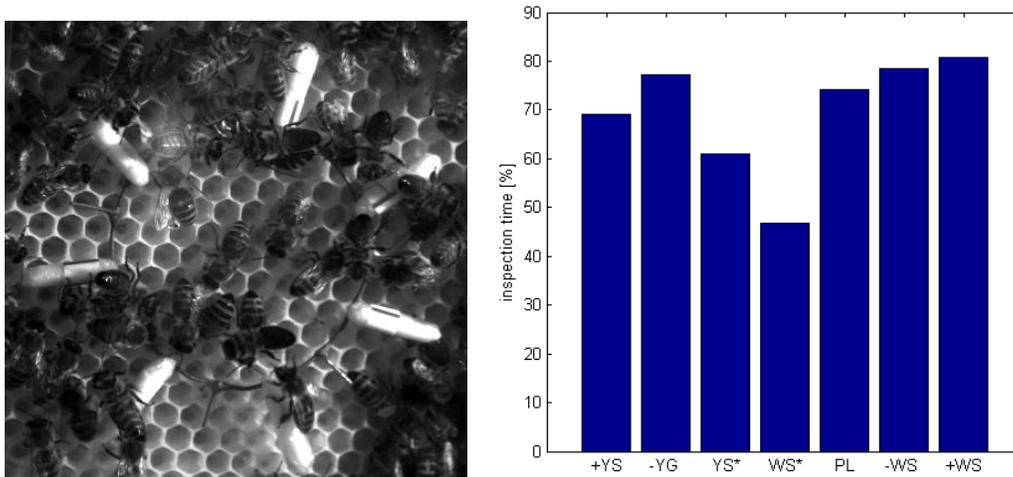

Figure 48: The left image shows a screenshot from one of the video recordings. A metal wire held seven different replicas corresponding to different treatments. The relative proportion of time in which bees inspected the replicas is depicted in the right plot. Treatments: +YS: yellow sponge, sealed. -YS: yellow sponge, leaky. YS\*: yellow sponge, sealed, hive scent. WS\*: white sponge, sealed, hive scent. PL: plastic foil only. -WS: white sponge, leaky. +WS: white sponge, sealed.

### 5.3 BEHAVIORAL STUDIES: SUMMER 2009

In the summer of 2009 the construction of the plotter-based prototype was finished. The robot was able to move based on the final parametric motion model and could produce dynamic electric fields. It had no wings nor was it able to give sugar samples. The body consisted of a plastic core that was enclosed in a wax jacket. The goal in those experimental trials was to learn about the motion of the robot and the reactions of the bees that had contact with the wagging replica. We wanted to learn whether the robot could induce following behavior or even recruitment using the electric field cue to “simulate” the wing buzzes. The second goal was to test the obstacle recognition cameras the first time.

#### 5.3.1 EXPERIMENTAL DESIGN

The hive used was, similar to the year before, a two-frame observation hive. A 15 cm x 15 cm window was cut in the front plastic cover to be able to insert the replica on the central rod of the robot. The replica was positioned 1 mm – 2 mm above the comb surface and different dances were imitated using different sets of parameters. An electric field was produced by replaying a recording of a natural dance fields through an amplifier. The output was connected to a shielded cable. The shield was removed at the end tip of the cable which was affixed onto the replica. Video recordings were taken and transcribed at the end of the season.



**Figure 49:** The wax coated plastic model is held into the hive through a 15 cm wide opening. The hive is back-lighted with cluster-lamps of red LEDs. Two embedded cameras are observing a perimeter around the wax model and signal the occupancy of 14 regions of interest around the model bee. The robot stops the dance automatically upon this signal and continues the dance once the path is freed again.

### 5.3.2 RESULTS

The wax coated model, as well as the pure plastic model, did not get attacked. Mostly, the robot was ignored, i.e. the surrounding bees free some space in which the robot can dance without running into other nestmates. No following behavior could be observed.

Without the vision system working, approaching bees, or bees that were standing in the way, sometimes got pushed away. Since the comb surface is not perfectly planar those bees got frequently squeezed between the replica and the comb. Most of the time this happened in the return run - shortly after or before the waggle run, when the turning speeds are highest. Presumably due to the emission of the alarm pheromone, this increases the overall excitement of the colony. Bees from relatively far away can be observed to come to the dance floor and touch and “ride” the robot, although they do not often seem to find the “intruder” instantly.

Using the vision system those situations become rare. However, the calibration of the sensitivity of the camera sensors is time consuming and has to be done every few days. This is due to two main factors: First, the backside of the comb gets populated after a while. The bees manage to lift up the comb from the plastic plate and are able to move in certain regions on the back side. Those bees block some of the backlight and this has to be balanced with a new calibration. However, those regions are dispersed over the whole comb. Calibrating the sensitivity of the camera such that those darker patches still are considered free space, results in a higher number of false negative detections. Second, the amount of brood and honey in the comb is variable. This again has an effect on how much light actually passes through the comb and the calibration becomes crucial.

The dance model and its implementation through the stepper motors are found to be working very well. The motion is smooth and the parametric model allows changes in just a few seconds. However, the replica is held by a stiff metal rod. There is practically no passive compliance when the robot runs over or into bees. The waggle amplitude had to be decreased to minimize aggressive behavior resulting from hitting bees several times against the head with a comparably high force and speed.

The electric field does not seem to attract bees nor does it seem to repel them. No effect on dance following could be observed. Bees from far away sparsely run directly to the robot, touch it for a short while intensively with their

antennas and front legs and leave. It remains unknown if electric or visual cues (normal day light was used) were responsible for this behavior.

Opening a window to the comb disturbs the bees, as shown in a previous test. The aperture gets closed by a curtain of bees after 5 min – 10 min. This renders any robotic motion impossible and limits the duration of its application. When the robot runs into the curtain, many bees fly into the room. Occasionally the experimenter gets stung. Each test had to be conducted within a 10 minutes interval to limit this disturbance. The window had to be closed again to let the bees normalize their behavior. Leaving the window open for an extended period of time does not result in an adaptation.

### 5.3.3 DISCUSSION

The fact that no following or attraction could be observed might be explainable by three factors:

First, the implemented signals, the dance motion and the electric field, might not be mimicking the respective natural cues properly. The dance motion was often interrupted by the vision system. The analysis of natural dancing however has revealed very tight temporal dynamics, i.e. the duration of the return run has a very low variance. Interrupting the return runs might have a negative impact on the ability of the followers to synchronize to the dance. The electric field was replayed in the waggle run but lacked synchronization to the waggle movements. Although Esch (1961) concluded that the buzzes of the wings are not in synchrony with the waggle movements, Uwe Greggers (personal communication) had observed this. Furthermore, the bee replica was held by a metal rod, which might alter the shape and strength of the electric field and might decrease its effectiveness.

Second, there might be signals missing for a number of different behaviors: Some signals might attract followers to the dance floor, activate their eagerness to follow or keep them following. Apart from unknown signals, those might be semio-chemical cues, like the “waggle-scent”, floral odors or nectar samples from the food source, body heat, or air flows and comb vibrations resulting from wing and thorax oscillations.

Third, RoboBee or the whole procedure of introducing the robot in the hive might have created disturbances that prevent bees from following. The observation of the “bee curtain” indicates a colony wide disturbance that might affect the readiness to respond to signals that would already suffice to trigger dance following. These disturbances include a temperature change, environmental odors that intrude the hive and air motion that all together might change the micro climate of the hive. Also the use of materials and glues, as well as electric fields emanating from the step motors might disturb the animals adding a negative quality the (potentially positive) effect of other stimuli.

The vision system proved itself helpful in preventing collisions. The amount of time that has to be invested for the calibration is too high, though. Maintaining the hive and calibrating the system prior to each test in this stage of the robot’s development might not be a feasible investment. It might be easier to use a simple manual remote control to stop the dance before an imminent collision. The movements of the bees, although very fast and chaotic, might be best recognized by a trained expert than by a computer vision program.

Apart from making active changes in the dance trajectory to avoid collisions some robot-to-follower contacts might be desirable. A passive approach to reducing the impact energy might thus be a part of the solution, too. Replacing the metal rod that holds the body of the robot with a plastic rod would improve not only the passive “compliance” but, as mentioned above, increase the effectiveness of the electric field.

## 5.4 RECRUITMENT EXPERIMENTS: SUMMER 2010

The first recruitment experiments took place in the summer of 2010. As a result from the experiments and experiences of the preceded summer, the robot was improved in several aspects: It got a plastic arm, a heating, a sugar water dispenser, a flapping wing, a new vision system and a manual control unit. The plastic arm was supposed to introduce flexibility when the robot would run over another bee and secondly, it shouldn't be affecting the electric field. Wings, sugar water and a built-in heating are putative signals in the communication system that might trigger or sustain following behavior. The new camera system was developed to improve the field of view and the frame rate of the recognition. Since I hypothesized that using the vision system might be too time-consuming, Michael Oertel helped building a manual remote control. Pressing just one button would continue the dance, whereas releasing it interrupts it.

First I conducted a row of experiments in Berlin with the help of Hai Nguyen and Marco Träger. Those first experiments were planned to, on the one hand, improve the acceptance of the robot and excite more interest in it. Secondly, I wanted to investigate the effect of the robotic dance on the foraging activity. Even if natural following behavior wasn't observable in the hive, an effect might be measurable outside.

Then, from end of July until end of September I joined the radar experiments in Klein Lüben, where the group of Randolf Menzel ran experiments on orientation and navigation of honeybees. Since we measured an effect on the foraging activity we wanted to track follower bees in their flight right after they followed the robot. Here, two more coworkers, Andreas Kirbach and Daniel Rhiel were involved in the work. We repeated the same set of experiments and started developing techniques for tracking follower bees that had contact with the robotic dance.

### 5.4.1 DESIGN OF ROBOT, USE OF SIGNALS

Again, the plotter-based prototype was used for this row of experiments. The central rod was replaced by a threaded rod. Wing nuts were used to affix a carved plastic holder for a small loudspeaker that produced the wing vibrations. The body was built from an artificial abdomen made out of PVC, a thermo sensor and two SMD<sup>8</sup> resistors. Those parts were integrated into a piece of drinking straw as depicted in Figure 50. The wings as well were built from a straw and could be slit over the body and were affixed with a small belt. The plastic arm had a small notch that was pressed into a latch in the replica. No glue was used, only tension forces produced by the plastic belt held everything in place. The wings were connected to the loudspeaker by a thin rigid wire. The sugar water was pumped through a small flexible tube that ended in a syringe tip at the head of the robot.

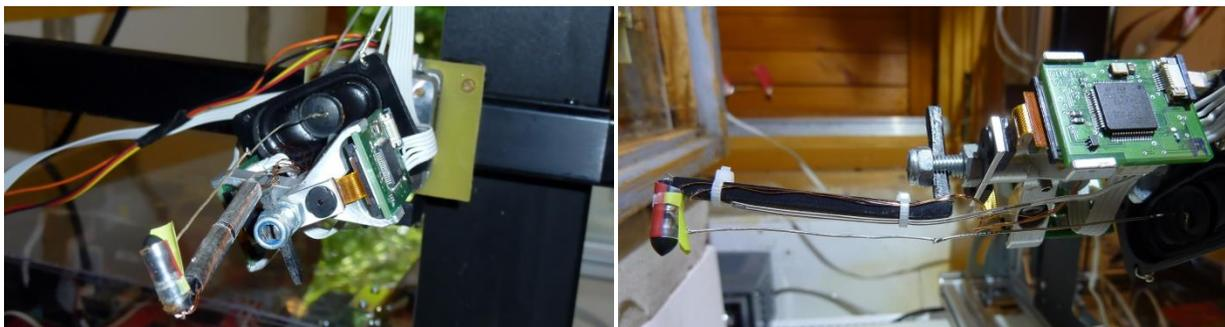

Figure 50: Prototype of the robotic honeybee as of summer 2010. The central rod, a threaded metal bar, carries the camera system, the loudspeaker for the wing pulses and a plastic elbow which holds the replica.

<sup>8</sup> Surface-mounted-device, (generally smaller) electronic components for the use on printed circuit boards

## 5.4.2 EXPERIMENT 1: EFFECT ON MOVEMENT ACTIVITY

### EXPERIMENTAL DESIGN

In addition to the stimuli emitted by the robot, the honeybees in the test-hive are exposed to a number of secondary stimuli. In order to analyze whether those stimuli have an effect on the activity of the bees, the stimuli were tested separately. I recorded videos before, while and after the stimulus was given and those videos were subjected to an optical flow analysis: a region in the camera image was defined such that it spans over the comb surface. Sparse optical flow features were initialized, tracked and renewed every 50 frames. The average global motion of the point features was then used as a measure of activity of the hive. The stimuli tested were:

#### Red and white light

Since video recordings need lighting, I usually used infrared light, known to be hardly perceivable by bees and humans. A second light source has to be used for the experimenter to be able to conduct the experiment. Bees are also very insensitive to red light (they are not blind for this wavelength). I noticed some bees to be phototactic towards red light LEDs. White lighting would be very convenient for the experimenter, so to tell whether red or white light disturbs the bees, videos were recorded (under IR illumination) with and without red or white light.

#### Opening the Hive

From the experiences of the previous summer it became clear that opening the hive leads to the formation of a “bee curtain”. To test whether or not the opening leads to more activity in the hive this stimulus was tested separately, too.

#### Inserting the Robot

The chemical signature of the robot might increase the bees’ activity regardless of the dance message. The robot was inserted for 5 minutes and then retreated. This, of course, was only possible by opening the hive, so any effects measured might surely be related to that treatment as well.

#### Moving the Robot without Dancing

The motion of the robot might stress the animals. The stepper motors are driven with alternating pulses of several hundred Hz. The operation of the motors results in electric fields and mechanical noise transmitted by the robotic arm. The mechanical construction might amplify some frequencies and those vibrations might as well be delivered to the comb surface or single individuals through touching. The test included several movement speeds and directions.

#### Moving the Robot with no Replica

Bees might be able to perceive electro-magnetic fields. The stepper motors and all the electronics of the robot are not shielded. Moving the robot using red or white lighting might also create visual cues that disturb the bees.

## RESULTS

### Lighting

There is an effect measurable when switching on white light. The effect quickly wears out over a period of 20 seconds. There is also an audible effect. The colony acknowledges the change in lighting with a slightly different buzzing sound that slowly fades into the normal background buzz. There is no such effect measurable with red light.

### Opening the Hive

Opening the hive leads to the buzzing sound and increased motion as a direct effect. Recording from a glass covered region of the comb, the effect slowly wears out until after a few minutes it converges to a level that is

comparable to the activity level before the treatment. In some cases the activity stays high and does not return to this steady state level within the time frame of the test.

#### **Still Robot**

Inserting the robot leads to similar results. The effect that relates to the robot is not discriminable to the effect of opening the glass cover.

#### **Moving Robot**

The motion of the robot in front of the closed hive does not lead to a significant effect on the motion activity.

### **DISCUSSION**

At least on the motion level, the lighting and the electro-magnetic fields of the motors do not influence the behavior of the bees. Opening of the hive does, though. This result suggests that bees adapt to the change of the hive's micro-climate only within certain limits. Furthermore, it might disturb the function of the hive, including the recruitment process with dances of bees and the robot. Natural dances and dance following were, however, observed during tests with an open window. It remains unknown whether those dances were effective.

The optic flow measurement has a high variability. The distribution of optic flow features depends on image properties such as edges and corners not whether the feature is located on a bee. Global optical flow from measurements in different times might not be comparable once the density of bees on the comb changed. Some portion of the flow features might capture no motion when they were initialized on comb structures. Fast motion on a sparsely populated comb might result in low values of the global motion activity. Although the density in all measurements was comparable from my point of view, there is no exact classification for each optical flow feature. Thus, the only trustworthy result is the strong effect of the light and the hive opening. There might be smaller effects that the optical flow method cannot resolve.

### **5.4.3 EXPERIMENT 2: RECRUITMENT TO SINGLE FEEDERS**

#### **EXPERIMENTAL DESIGN**

To simplify the investigation of a possible effect on foraging I pre-trained bees to an artificial food source 215 m away from the hive. This group established a memory of that particular location and therefore might be recruited easier than naïve bees. The experimental trials are all arranged in three phases. In training, usually a few days long, the bees fly to an artificial flower offering unscented sugar solution. Every bee that visits and collects sugar water from the feeder is tagged with a number plate. Then, the sugar supply is shut down for a whole day in the pre-test phase. Throughout that day the bees learn that the food source is depleted. They keep visiting the feeder, but with decreasing frequency until, at the end of the pre-test, they remain in the hive for most of the time and only occasionally visit the feeding site. On the following day, the test, a robotic dance is performed. All arriving bees at the feeder are counted before and after the robotic dance. This is repeated several times with different stimulus combinations, dance durations and dance locations on the comb surface.

#### **RESULTS**

Bees frequently touch, lick and orient themselves towards the robot; they follow the robot to suck the sugar water from the syringe when it is moving. Many bees do receive stimulation by the wagging robot for several waggle runs in a row, i.e. they stand in vicinity to the wagging robot body with clearly observable antennal contacts. However, they do not show the typical following behavior.

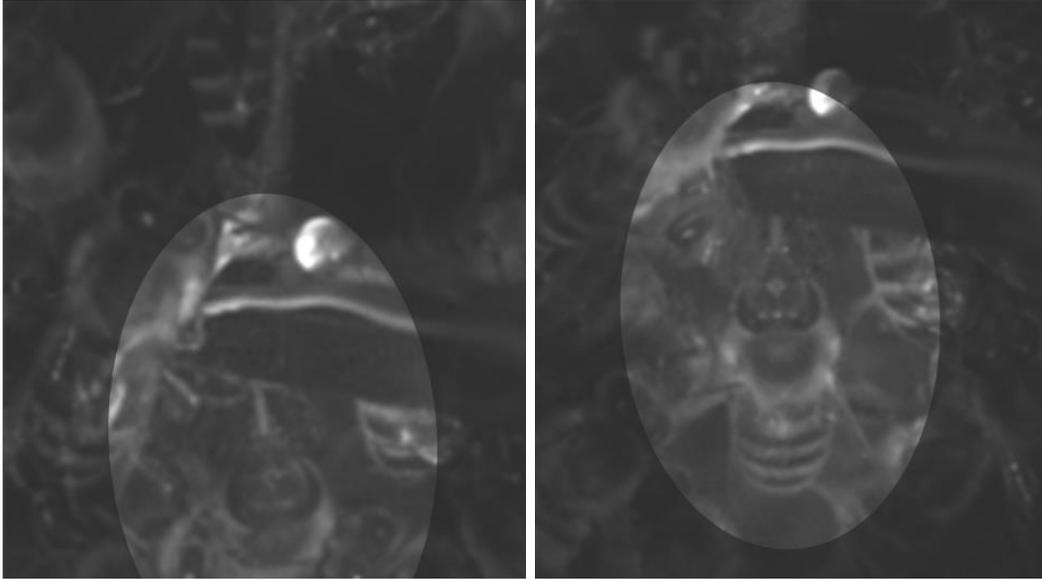

**Figure 51: Photographs of honeybees licking sugar samples from the mouth part of the robot. The trophallaxis might be very short (less than 300 ms). Most of the time the bees lick significantly longer (a few seconds). Depending on the volume of sugar water available bees do not stop drinking until sugar is depleted.**

The “bee curtain”, i.e. the clumping of bees, observable 5 min – 10 min after opening the hive could be delayed by heating the room. In some tests (20 minutes dance duration, 27 degrees room temperature) - could be conducted without clumping at all. However, in some other tests, that exhibited the same room temperature did show clumping behavior. Which combination of environmental parameters causes this effect remains unknown.

The new vision system is faster and more robust than the previous prototype. It enables the robot to react in real time: it decreases the amplitude of the waggle motion when bees would get hit near the abdomen of the robot. Still, it is relatively laborious to set it up properly. Since time is precious in summer, I decided to use the robot without vision system to be able to focus fully on the biological questions. The manual controller worked well. After a few weeks I have learned to interpret and anticipate the motion of the crowded hive while using the robot. From a practical point of view, the semi-automatic control of the robot is optimal. The dance can be interrupted at any time, simply by releasing a button. The replica can be moved and turned using buttons as well. Experimenting has become a lot easier, but requires training of the experimenter.

Although no dance following could be observed, the visiting rate at a pre-trained feeding place increases after the robotic dance. This effect could only be measured with dances that exhibit wing oscillations. Figure 52 depicts the cumulated number of bees visiting that feeding place over the time of day. The vertical black lines denote the start and the end of the robotic dance, respectively. The slope of the function signifies the arrival rate over a certain period of time. The average slope is depicted by the solid red lines. The robotic dance has an effect on the arrival rate. This rate is increased significantly only when wing oscillations are used. In only one test the effect is not significant (not shown here – only 2 individuals were observed to forage before and after the test). The arrival rate *during* the test is reduced substantially. If any, only few bees arrive at the feeder while the robot is dancing. The described effect does not depend on the dance direction. Figure 52 (top left) shows the arrivals before and after a test in which the robot pointed to a virtual, i.e. non-existent, feeder 180° away from the trained direction. Only opening of the hive does not lead to the described effect.

## DISCUSSION

The last result coincides with previous reports on silent dances (Esch, 1964) that fail to recruit new foragers. The lack of direction specificity suggests that the measured effect might be an “activation” of the foragers. Even pointing the robot in the opposite direction leads to an increase of visits at the trained feeding site. The robotic dance thus might be affecting the foraging motivation; however, without being able to actually count arrivals at the virtual feeder, we cannot conclude that there is no communication of direction or distance. This would require a change of the experimental setup as described in the following section on experiment 3.

The lack of following behavior might be explained by the dominant result of experiment 1: Opening the hive is a substantial disturbance and might therefore affect the readiness of foragers for new recruitment. It might also be possible that some signals are missing that either activate the following or make the dance traceable once it started. Chemical cues might be well traceable in the darkness of the hive as well as comb vibrations or heat sources. It is sensible to think that the following behavior is a prerequisite to decode the direction and distance from a dance. Anyhow, bees might still be able to read partial information from the robotic dance without following.

### 5.4.4 EXPERIMENT 3: RECRUITMENT TO A KNOWN OR UNKNOWN FEEDER

#### EXPERIMENTAL DESIGN

To be able to tell if any effect measured at the feeding site is specific for that site (or direction), i.e. whether in some way the robot communicates directional information, we trained a second group of animals to a second feeding station. This second source was located equidistant from the hive and 110° from the first feeder. The training, pre-test and test phase were executed similarly to experiment 1.

#### RESULTS

Two different groups were successfully trained to the two feeders. The robot’s dance direction indicated either the first or the second feeding site. At both field locations a significant effect was observed: After the robotic dance, bees responded by visiting their respective feeding site irrespective of the dance angle. Bees of group 1 flew to feeder 1 and the same holds for the other group. Not a single bee of a certain group was observed at the other feeder.

Controls that investigated the effect of silent dances confirm our previous results. Silent dances do not lead to the increase of arrivals at the feeding station.

No following behavior could be observed.

#### DISCUSSION

Similarly to experiment 2, the measured effect, i.e. an increased rate of visiting the feeder, is coupled to a vibratory stimulus, the wing vibrations. However, the results suggest that the robot could not deliver directional information or. Although unlikely, suppose it might have communicated direction. The receiving bees might have ignored the message. Recently, this has been reported to be often the case for natural dances too. Under natural conditions bees might not follow the information encoded in the dance and fly to the experienced field spot rather than to the communicated feeder (Grüter, et al., 2009; Grüter, et al., 2011; Menzel, et al., 2011). The number of waggle runs followed seems to be a crucial predictor for the outcome. Bees following more than 20 waggle runs most likely fly to the new field coordinate (Menzel, et al., 2011).

However, no dance following could be observed in the robotic dances. It can be concluded that the communication of direction might require dance following. Still, it cannot be completely ruled out that the robot is able to communicate direction and distance; although probably not very effectively. The experimental design had two basic flaws that might have prevented it to reveal this small amount of efficiency: First, the asymmetry of the experience of the two groups given a robotic dance to one of the feeders. The dance points to a known spot to one group, but to an unknown location for the other. If those locations are the only field sites that both groups experienced and both groups are similarly sized it might not be surprising that - without following behavior – both groups showed up similarly more often at their respective feeders.

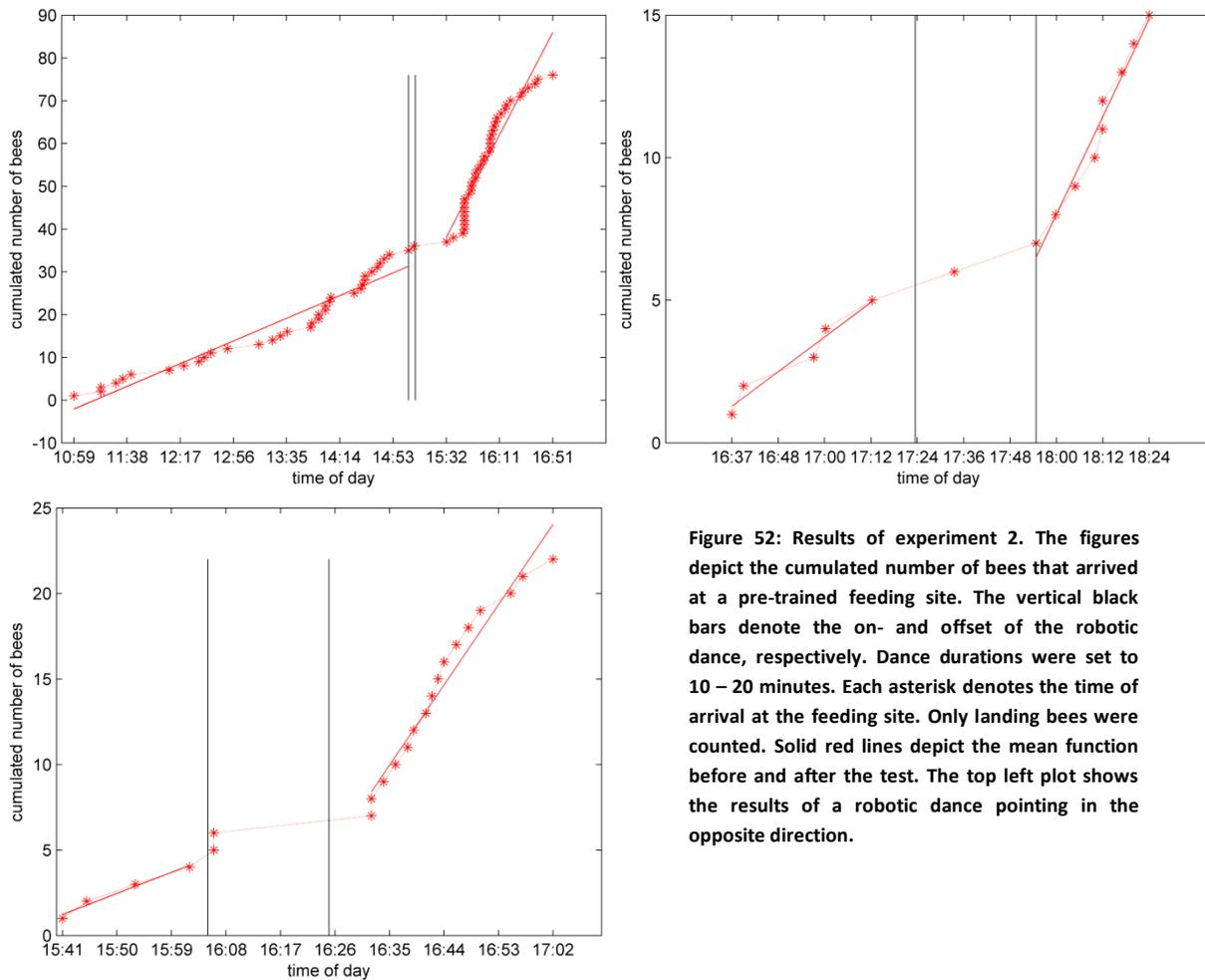

**Figure 52: Results of experiment 2. The figures depict the cumulated number of bees that arrived at a pre-trained feeding site. The vertical black bars denote the on- and offset of the robotic dance, respectively. Dance durations were set to 10 – 20 minutes. Each asterisk denotes the time of arrival at the feeding site. Only landing bees were counted. Solid red lines depict the mean function before and after the test. The top left plot shows the results of a robotic dance pointing in the opposite direction.**

There must exist a certain threshold - e.g. the number of waggle runs decoded – that has to be exceeded in order for an individual to visit the new spot. This threshold supposedly is higher for naïve bees than for bees that know the respective location. Given the disturbances and the lack of following behavior, bees did not receive stimulation from the waggle phase for more than 10 waggle phases. From (Menzel, et al., 2011) we know that the number of waggle runs a bee has to follow to be likely to show up at the communicated feeder is around 20. In addition, the followers that were observed in this study, followed actively as opposed to those bees that were close to the robot. This renders it very unlikely to observe naïve bees showing up at the previously unknown feeder.

In order to recruit naïve bees, either the robot has to be improved substantially or a change in the experimental procedure has to be made: Only one group has to be trained to two distinct feeding sites. Their memory of both

sites has to be approximately equal in order to face an equal threshold for “understanding” the robotic dance. The training would involve carrying individuals from one to the other feeder for several times and therefore would require some effort to create the memory. Once a bee has found a rich source of nectar, it usually stays there until it is depleted; thus a convergence to one or the other feeder could be expected. However, for some days the number of visits and thus the expected experience with both feeders might be comparable for enough animals.

The second flaw of the experiment is its limited registration technique. Only bees that land at the feeder were counted. Bees that are naïve for a feeder need much time to locate the artificial sugar solution. Compared to a flower patch, the feeders are relatively small and might be considered dangerous since a person is sitting near to it. Counting only those bees that land excludes most of the possible recruits. Here, some technical solutions would improve the setup, including RFID, or camera registration techniques, as well as harmonic radar techniques. All those methods require a relatively high amount of labor for marking the bees with RFID chips, or paint marks, or for running the necessary infrastructure. Nonetheless, I had the privilege to take part in radar experiments, as described in the following section.

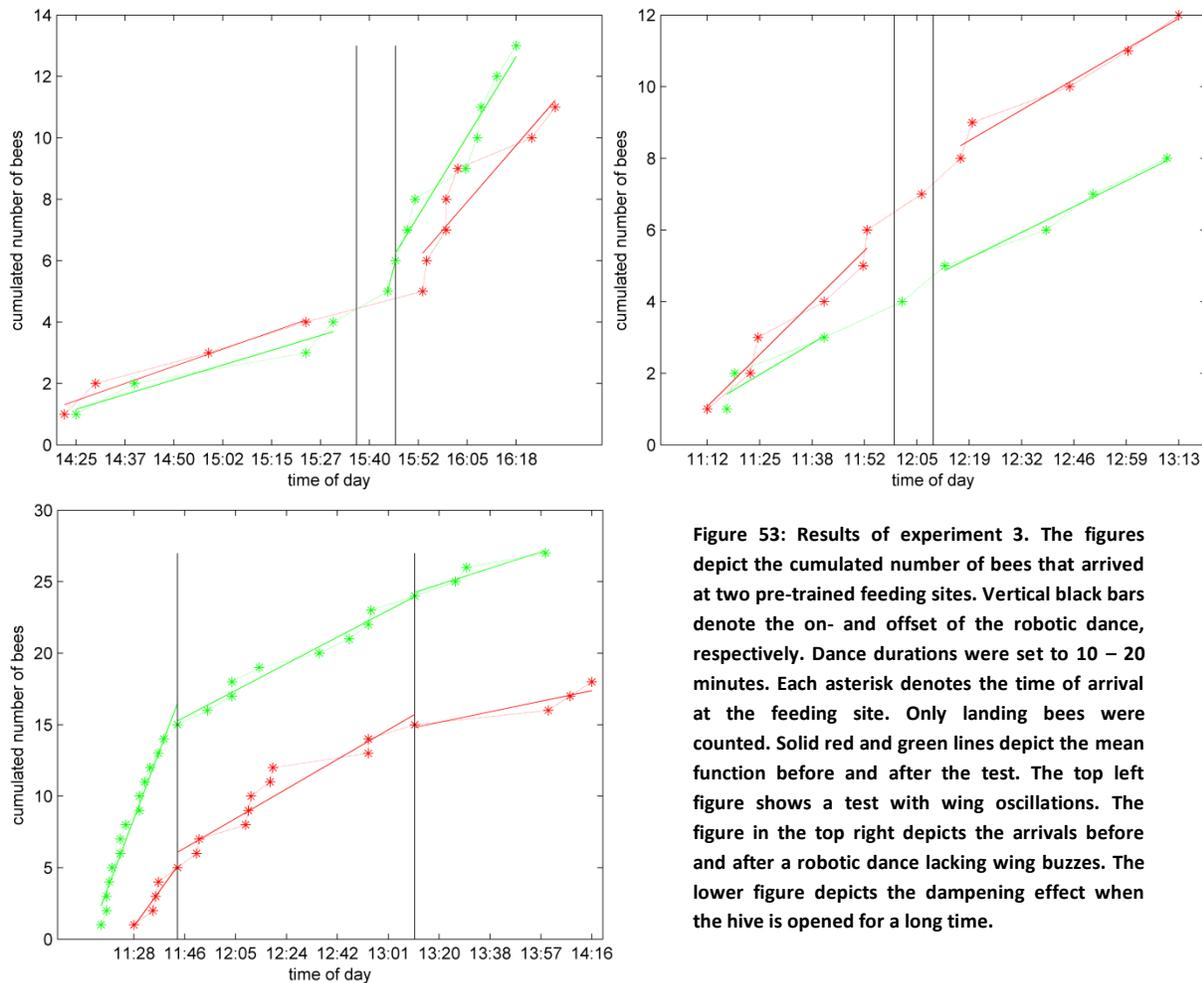

**Figure 53: Results of experiment 3.** The figures depict the cumulated number of bees that arrived at two pre-trained feeding sites. Vertical black bars denote the on- and offset of the robotic dance, respectively. Dance durations were set to 10 – 20 minutes. Each asterisk denotes the time of arrival at the feeding site. Only landing bees were counted. Solid red and green lines depict the mean function before and after the test. The top left figure shows a test with wing oscillations. The figure in the top right depicts the arrivals before and after a robotic dance lacking wing buzzes. The lower figure depicts the dampening effect when the hive is opened for a long time.

## 5.5 RECRUITMENT EXPERIMENTS: SUMMER 2011

One of the main results of the previous experiments was, that very likely disturbances – caused by opening a window to access the comb surface – impair the colony’s proper functioning, including dance following and,

eventually, recruitment. Accordingly, in the winter 2010/2011 a new feature was added to the robot's hardware design: a thin plastic plate that covers the aperture while the robot is dancing in the hive. This plate moves with the robot, except for the fast waggle movements. In addition to those changes, the wing mechanism had to be redesigned completely.

The time and energy for the preparation of the following experiments was substantially increased in comparison to previous tests. The time invested for actual tests was reduced to only a small portion of the whole season. The main motivation for this year's experiments (the last in the funding frame) was: could the robot excite following behavior? Could it eventually recruit followers, and would we be able to track their flight with the radar system? In order to excite a higher interest in the robot - in addition to reducing the disturbances - we used, in a preliminary experiment, a scented sugar solution very close to the hive. Using this scent on the robot would possibly make those bees more interested that had experienced the association of sugar and scent. Secondly, we repeated last year's experiments improving the mentioned flaws: we trained one group of bees to two feeders and we planned to use the radar system to track flights of possible recruits. Even with no following behavior we would at least learn about the path recruits take to arrive at their prospective feeders.

The experiments were conducted in Klein Lüben, Germany. The robot and the observation hive were kept in a wagon on a area of flat farmland. On the same field, the radar system was set up. Figure 54 shows a top view of the field and the radar and hive sites.



Figure 54: Left: Satellite view of the experimental field in Klein Lüben. The Radar and the Hive were positioned close to the road. Feeding sites were distributed in the field in various positions. The sites shown here correspond to an experiment conducted in summer 2011. Top right: A photograph of the radar system shot from the hive wagon. The radar dishes were secured with a wind shield. The radar dispatcher sits in the orange wagon. Bottom right: The hive and the honeybee robot are installed in a second wagon (the photo was taken from the radar position). Throughout the seasons, I mostly stayed in a tent close to the wagon.

### 5.5.1 DESIGN INNOVATIONS -- USE OF SIGNALS

The plastic plate, a 1 mm thick poly-carbonate sheet, is held by four rods that are connected to the orientation motor. Every translational movement is therefore followed by the rods and thus by the plastic plate. The central rod is channeled through the plate, exposing only the replica to the inside. A plastic arm holds the replica very close to the plate (approx. 5 mm – 8 mm), serves as the holder for a small flexible tube through which sugar water is delivered and integrates the rocker mechanism for the wings. In most of the experiments I used a replica that was stripped down to the basic stimuli: a soft body, a wing and sugar water. In some experiments we used a peppermint-scented sugar solution or applied the scent directly to the body.

## 5.5.2 EXPERIMENT 1: INCREASING INTEREST IN THE ROBOT

### EXPERIMENTAL DESIGN

A scented feeder (peppermint, 2 M sucrose) was put directly in front of the hive exit and a number of bees were trained to forage from it. The scent was not mixed with the sugar solution. A few drops of peppermint oil were put onto filter paper in a dish. The feeder containing the sucrose solution was simply put on top of this dish. Bees foraging from the feeder were thus exposed to the scent but did not bring it into the hive with the artificial nectar. Recruits were number tagged and the solution was offered until the group size reached 50 individuals. Then the feeder was closed and after a certain time (up to one day) the robot was used to dance to a virtual feeder 300 m and 600 m away from the hive. The feeder and the scent were removed right after the training. The replica was brushed with peppermint scent using a cotton swab.

### RESULTS

The plastic plate drastically improves the handling of the robot because the bees stay calm. Inserting the robot into the hive does not lead to an increase of motion activity at all. Bees do not fly out of the hive into the room. The clumping of the bees near the window is not observable anymore. The robot can be used for a very long time. If it weren't necessary to isolate the hive for the night (Styrofoam plates had to be put on the glass sides), the robot could stay in the hive for the whole season. Recording videos becomes harder though since more reflections hinder the direct sight onto the replica. Bright components of the robot and the environment were painted black in order to reduce the reflections.

Neither an apparent increase of interest, nor following behavior was observable with the scented dances. Tagged bees would shortly contact with the robot but then walk away. Some even "flip" around quickly on touching the robot. Dances with a heated replica were not followed as well.

### DISCUSSION

Using the plastic plate to reduce disturbances improves the experimental setup but did not lead to following behavior. Also the use of the scent did not create a higher interest. This might have many reasons, among which one might be probable: there is practically no need to follow a dance. It is well known that scents do trigger forage trips. It activates the memory of the place, which in our case was very near to the hive, so the cost of inspecting it again is rather low. It might not be feasible for a forager to invest energy to decode a dance and then to locate the field spot compared to just visiting the known location. However, at some point, the foragers must follow dances if the known sources are depleted and no other source can be found. It remains unknown whether this state was already reached for the tagged foragers. If it wasn't it might explain the results. If it was reached, neither the scent nor the heat did help in exciting the following behavior; as for other bees as well. I frequently observed bees flipping away their whole body after touching the robot with their antennae. This might suggest that the scent, or the combination of the scent and the body material, repels rather than attracts the bees. Heat alone did also not lead to an increase in interest. We hypothesized that the lack of traceability is the reason why bees do not switch to or continue the following behavior. Traceable stimuli such as heat or scents might still be used in natural dances but their imitation on the robot might not have been done correctly. Comb vibrations might be a source of traceable stimuli as well. Although the robot does not have legs, it sometimes touched the comb surface for entire return runs. It nonetheless did not excite more interest. However, walking surely creates a different comb vibration than sliding a robot over it. It remains unknown if comb vibrations are essential for the excitation of following behavior.

### 5.5.3 EXPERIMENT 2: TWO FEEDERS, ONE GROUP

#### EXPERIMENTAL DESIGN

A group of bees was trained to forage from an unscented feeder (“FB”, up to 2 M sucrose) 300 m away. Then, foragers that visited that feeder were caught and brought over to a second feeding site (“FA”), approximately 60 degrees from the first feeder, having the same distance to the hive and to Feeder B. This procedure was repeated until many bees (~ 40 individuals) kept returning to FA. The training was continued until the end of the day (~ 6 pm). The next day the same was repeated vice versa. Bees that visited FA were caught and brought over to FB. After some days of training a group of bees kept coming to both feeding sites, of which only one offered sugar solution at a time for durations of one to three hours. While training, a continuous protocol was taken of all bees that visited FA or FB, respectively. Newcomers were tagged but not brought over to the other feeder. Hence, among the tagged bees there were some that experienced both feeders and some that only knew FA or FB. Before the test, both feeders were closed for up to one day. For some tests this “extinction phase” (the bees learn that the feeders do not offer a rewards, i.e. the reward memory becomes “extinct”) took longer because of weather conditions (rain, strong winds). The test, the robotic dance, was pointed to the feeder that was not rewarded before, or to a virtual feeder (“FC”).



**Figure 55:** Left: For the first experiment, a scented feeder was put close to the hive. After little time many bees were visiting the dish. The second experiment involved training the bees to remote feeding locations. The right photograph depicts one of those spots in the field.

All tests were audio and video recorded at 50 fps using no artificial, but only diffuse day light. The camera was set up to overview the entire dance floor, hence the identity of tagged bees could not be recorded on video.

I operated the robot for dance sessions of around 15 – 30 minutes duration. Depending on the state of the hive, the dance was paused for up to 15 minutes; the robot was “parked” in a corner of the dance floor, mostly the lower left, i.e. close to the exit. One person, most of the time Ms Rachel Cusing, sat close to the hive and reported the IDs of bees that showed interest in the robot. This would apply to animals that have antennal contact to the wagging body of the robot more than a few times and the animals display the intention to repeat this. When one of those bees would exit the hive, an appropriate signal would be given to a person outside via radio. This third person, most of the time my colleague Andreas Kirbach, observed the hive entrance, took note of the reported IDs and waited for the second person to call the exiting bees. He then waits for the bee to show up in the last couple of centimeters of the exit tube and then catch, glue a transponder onto and eventually release her. He would

report the id to the dispatcher in the radar wagon where the time and identity and the radar paints of the following flight would be recorded.

## RESULTS

### FOLLOWING BEHAVIOR: FREQUENCY OF FOLLOWING

A large group of bees (~ 50 animals) was trained to forage from both feeders. An equally large group of bees had visited only one of the two available feeders. The training was occasionally accompanied by robotic dances.

After two weeks of training, some bees (mostly unmarked) showed seemingly natural following behavior. They ran towards the wagging robot, stood still with antennae extended and followed the return runs quickly and without any sign of aggression. For the trained eye the way how those bees move along with the robot is very similar to the movements follower bees perform within natural dances. From my perspective the similarity is remarkable; therefore I use the term “follower bee” analogously. In this section I describe the analysis of the frequency of the behavior. A comparison on the level of the body motion is given in the subsequent section.

All video recordings were reviewed and for each bee that showed following behavior the number of continuously followed waggle runs was recorded. In order to be registered the behavior had to be displayed over the sequence *waggle – return – waggle – return- waggle*. If the animal misses one robotic waggle run (i.e. the distance of her head to the dancers body exceeds half a body length for more than a second), the continuous sequence would be interrupted. If then continued further any new following would be counted as a new sequence.

Video material of 8 days (within a two weeks period) was evaluated. In total, 81 following sequences were identified, adding up to 571 followed waggle runs. In average, a bee followed approximately 7 robotic waggle runs before interrupting.

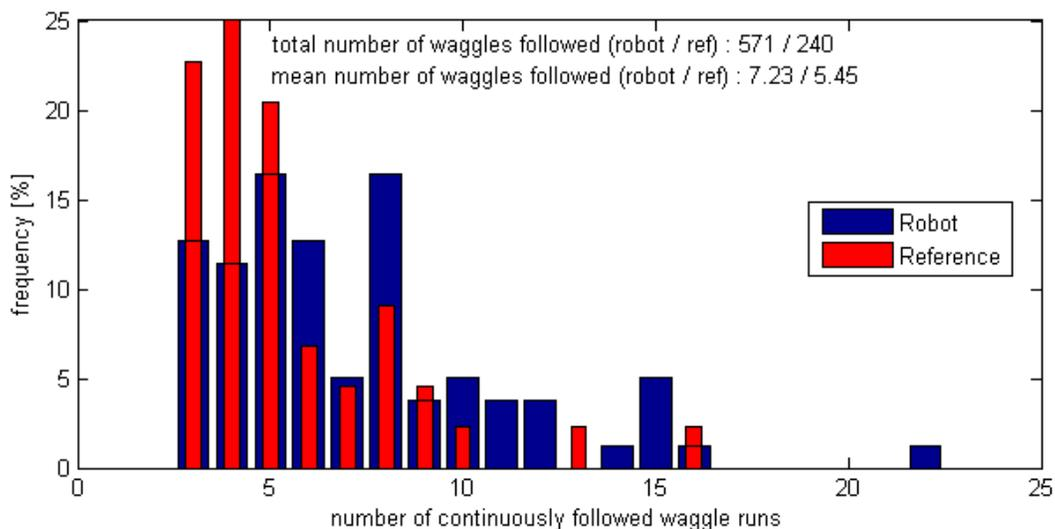

**Figure 56:** Histogram of the number of continuously followed waggle runs for bees that followed the robot (blue bars) and bees that followed natural dances (red bars). Short following runs are excluded in this plot. By including following behaviors of one or two waggle runs the shape of the distribution would be similar to an exponential decay.

The same analysis was performed for natural dances. Ten video recordings of waggle dances (used also for the analysis in (Landgraf, et al., 2011) ) were randomly selected and reviewed analogously. The histogram of the number of continuously followed waggle runs is depicted in Figure 56 for both groups. Remarkably, the mean

number of followed waggles in natural dances is even lower than in robotic dances. This difference is very significant (T-Test:  $t = 2.7472$ ;  $P = 0.0069$ ) and is discussed below.

In both groups, most bees that followed were unmarked. It was thus not possible to track how many waggle runs were followed before a follower is recruited. For those few marked bees that followed the robot it is possible to calculate a total of waggle runs followed as depicted in Table 6. Note that the actual number might be higher since short following runs were ignored.

ID	Total number of waggle runs followed	Number of days followed (days in between without following)	Radar flights recorded
? 45	51	2 (0)	No
ng71	47	2 (1)	Yes
ng62	31	1	Yes
ny18	29	1	Yes
?70	18	1	No
ny47	8	1	Yes

**Table 6:** For 6 marked animals following behavior could be recorded to video. They followed an average of 30.7 waggle runs. Most of the animals followed a single day only. Two animals were observed to maintain interest in the robot the next day, or even after a day with no following record.

### ANALYSIS OF FOLLOWING MOVEMENTS

For the analysis in the previous section I watched all video recordings and noted how many following runs were observable. Each video that contained following behavior was then marked for further processing which is described here. This section shows the analysis of the body motion of follower bees and gives a comparison between motion features of natural dance following and the following behavior along robotic dances. For each video the position and orientation of the follower bee and the robot was marked manually with a custom program. A rectangular box was overlaid onto the video frame. The box could be moved using simple mouse gestures and the video was advanced frame by frame using keyboard commands. The resulting trajectories contained for all points in time (i.e. frames) a position in the video frame (unit: pixels) and an angle.

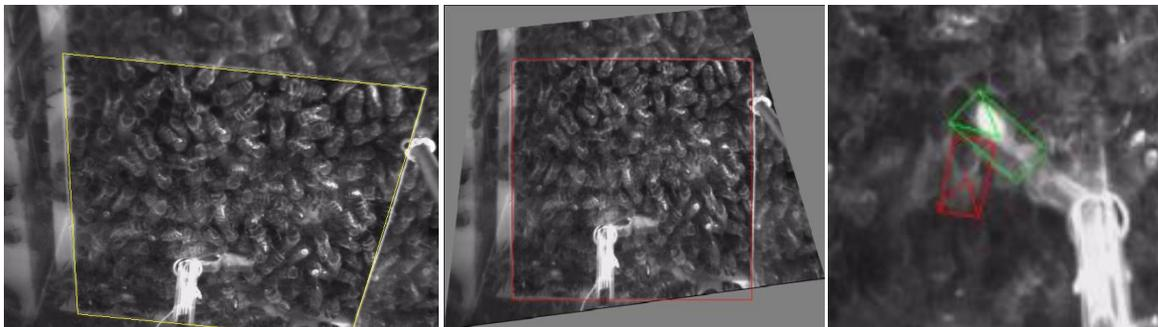

**Figure 57:** The skewed perspective of the camera had to be corrected before any tracking data could enter the analysis. The left image shows a frame from the original video with a yellow quadrilateral which is set manually and used to rectify the image (center image) and the tracking data (right image). For each frame the data consists of a position and an angle, displayed here as a rotatable box (green: the robot, red: the follower).

The camera viewing angle was not perpendicular imposing the need for a rectification of the frame. Therefore, the coordinates of the four corners of a rectangle of known dimensions (the window through which the robot is inserted) were extracted for each video file. Using Matlab I was then able to calculate the homography matrix  $H$  mapping image coordinates  $x_f$  to real world coordinates  $Hx_f = x_r$ . A second preprocessing step was to interpolate

the data to “fill” gaps in the manually obtained data: in the return runs, the positions of the follower bees were extracted every 10<sup>th</sup> frame only (the recording frame rate was 50 Hz, thus extracting positions with 5 Hz). In the last step, the robot’s waggle runs were manually marked, generating a tall matrix with numbers denoting start and stop frame indices for each waggle per row.

Reference data was extracted from video recordings of natural dances as well: For each dancer in such a recording all followers were tracked similarly. All dance and following trajectories were rotated to eliminate the influence of time. After the rotation, the mean of all dances of different recordings point to the same direction. Followers were tracked starting from a certain frame index until they leave the borders of the video frame or stop showing vital interest in the dance. They might lose close contact to the dancer for a short time even in between highly motivated following. A preprocessing step calculated those subsequences in which the follower bee had close contact (less than 7 mm head to body distance) to the dancer. This binary mask was filtered with morphological operators to first clear short sequences (shorter than a tenth of a second) where the bee was said to be close and, secondly, tolerate “gaps” where the follower might have exceeded the threshold distance for a short time (less than one second).

In order to capture the similarity (or dissimilarity) between the motion of both groups I chose the following measures:

**a) The euclidian distance of the follower’s head to the body axis of the dancer (or the robot, resp.)**

Very likely, the followers’ antennas are involved in receiving cues transmitting meaningful information. The distance of the head to the dancer’s body gives a good perspective of what the bee might be able to touch. Although some cues might be receivable without physical contact (particle oscillations, laminar airflows, electric fields) they all are effective in close range only.

**b) Cosine of the bodies’ relative angle (dot product of direction vectors)**

The angle between the two individuals has to be characterized. I use the dot product of both unit vectors that describe the body orientation of both animals which is nothing other than the cosine of the mutual angle. If the follower is aligned with the dancer (heads facing the same direction), the dot product is equal to 1, if they face each other the dot product is equal to -1. If the follower stands perpendicular to the dancer (head to abdomen or abdomen to abdomen) the dot product will be equal to 0 (by taking the head to body distance in to account both situations can be discriminated). The cosine is symmetric, i.e. a follower standing at the abdomen at a 90 degrees angle result in the same dot product as in – 90 degree configuration.

**c) Average forward, sideward and turning velocities throughout full waggle cycles**

The motion velocities of follower bees in the three-dimensional ego-centric coordinate system are functions over time. By averaging over all sequences it is possible to compute the salient, predominant motion patterns that make up the stereo-typical following behavior.

**d) The average position of the follower throughout a waggle cycle**

The body position over a full waggle cycle (*waggle – return – waggle – return*) might reveal a specific pattern that one can use to compare trajectories of the robotic dance group and the reference. This average path is obtained by integrating the average motion velocities described above.

Generally, the collected data shows highly stereotypical behavior. The followers approach the dancer from the sides, sample the waggle run, switch sides, follow closely the return run and sample the next waggle run. Figure 59 shows a sample snapshot sequence through half a dance cycle. In a typical following behavior sequence three

notable features can be observed frequently: First, the followers push themselves to a position close to the sides of the dancer. Often they stand in a perpendicular position with respect to the dancer's orientation. Second, short after the waggle phase the follower seems to wait for the dancer to initiate the return run. The dancer turns and exposes her other side to the follower. Only then the follower starts moving quickly forward to stay in contact with the dancer. Third, the followers try to keep close contact throughout the return run. The head and antennas are always oriented towards the dancer's body. In order to describe this behavior numerically the above mentioned measures have been extracted from reference data (natural dances and dance following) and experimental data with robotic dances.

### Head to Body Distance and Mutual Angle

For all sequences *waggle – return – waggle – return* the distance of the follower's head to the dancer's body axis and the dot product of the body direction vectors was extracted and stored. In total, 155 sequences were collected for following tracks in the robotic scenario versus 88 sequences for the reference. Since the duration of those sequences varied significantly I resampled the data to a unit duration. Figure 58 shows the mean function for both groups. Although the head to body distance is in average 1 mm higher in the robotic scenario, the shape of both functions is remarkably similar. Throughout the waggle phase ( $t = 0\% - 10\%$ ), the head distance stays around 5 – 6 mm. When the dancer turns into the return run ( $t = 10\% - 30\%$ ) the head to body distance drops to a low value (4 – 5 mm) right before the follower switches sides ( $t = 20\%$ , dot product at its maximum in Figure 58). Throughout the entire return run ( $t = 10 - 100\%$ ) the head to body distance stays smaller than a body length (means for robotic vs. natural dances:  $\sim 5$  mm and 4 mm, respectively) but tends to increase over time.

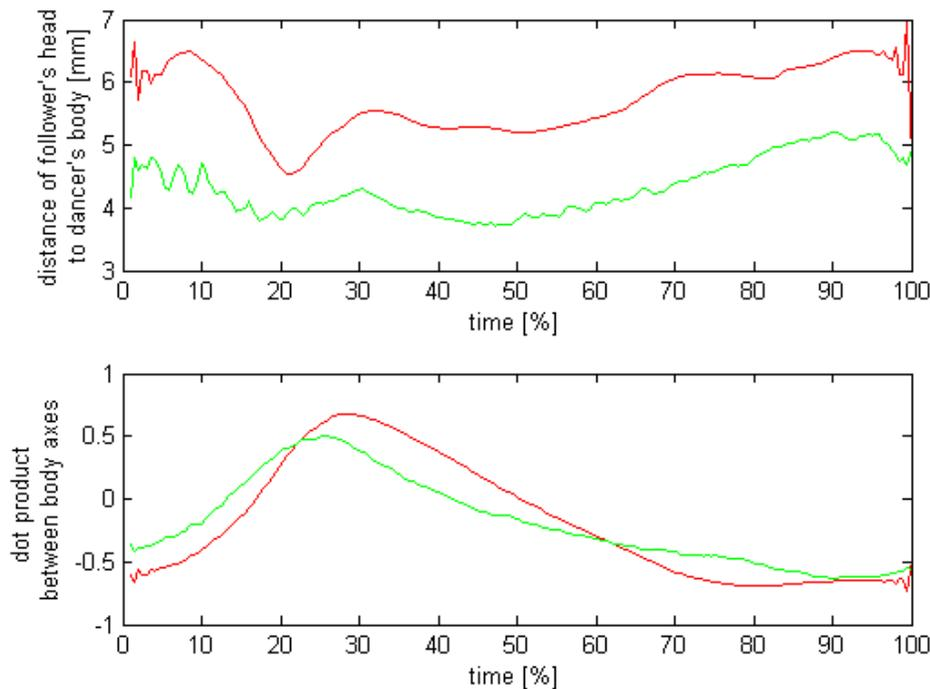

**Figure 58:** Mean distance of the follower's head to the dancer's central body axis and the mean dot product of both body direction vectors over a unit period of time. Time  $t = 0$  corresponds to the start of the waggle,  $t = 1$  denotes the start of the ensuing waggle. The red curves show the data extracted from robotic dances; the green data displays the reference data extracted from natural dance recordings.

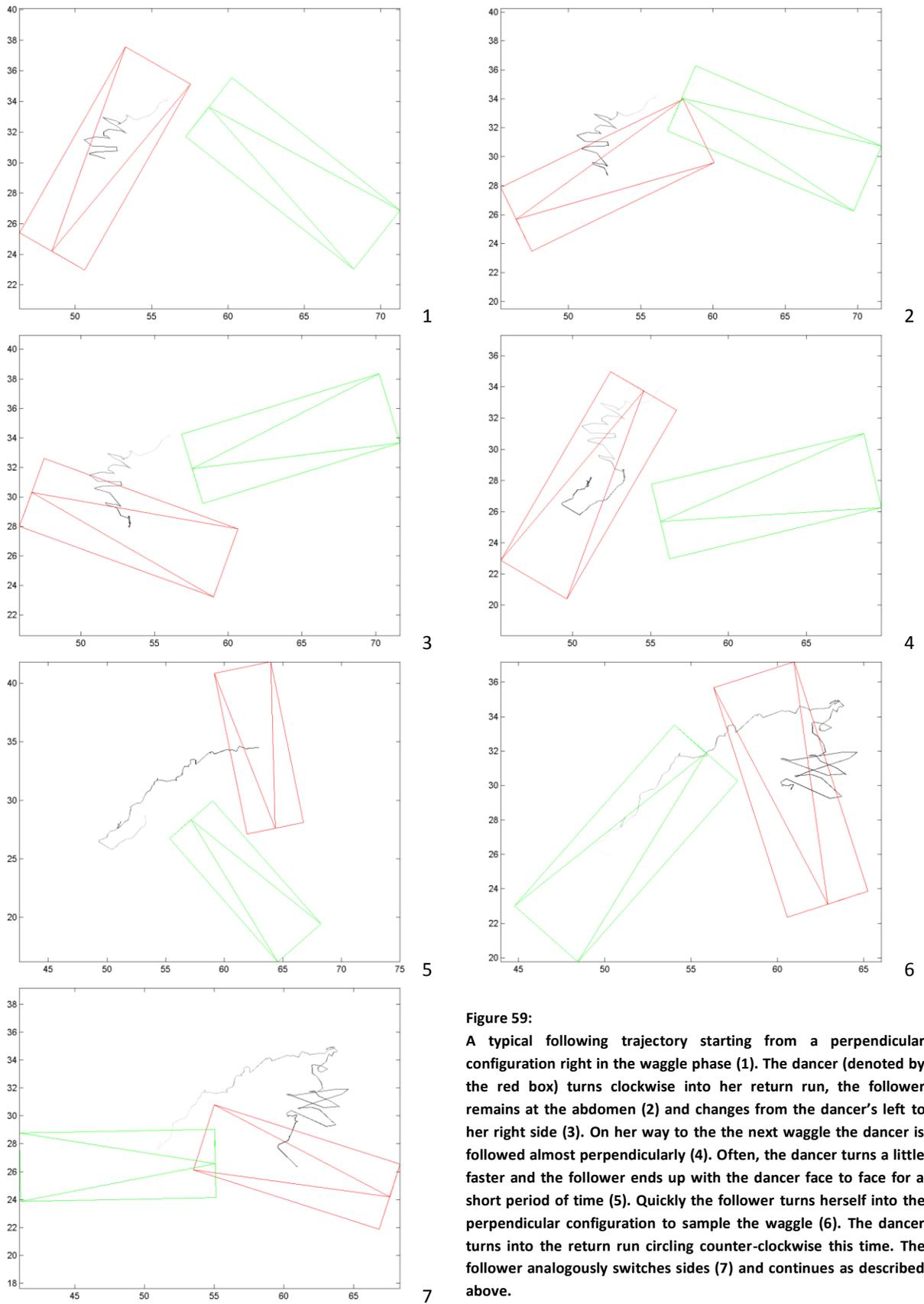

**Figure 59:**  
 A typical following trajectory starting from a perpendicular configuration right in the waggle phase (1). The dancer (denoted by the red box) turns clockwise into her return run, the follower remains at the abdomen (2) and changes from the dancer's left to her right side (3). On her way to the next waggle the dancer is followed almost perpendicularly (4). Often, the dancer turns a little faster and the follower ends up with the dancer face to face for a short period of time (5). Quickly the follower turns herself into the perpendicular configuration to sample the waggle (6). The dancer turns into the return run circling counter-clockwise this time. The follower analogously switches sides (7) and continues as described above.

Both functions show a similar behavior. Also both groups show similarities in the dot product. Both functions start from negative values (corresponding to a configuration similar to Figure 59, subfigure 4), cross values around 0 after the waggle ( $t = 10\%$ ), overshoot to values near 1 (when the followers switch sides) and come back to values close to the starting point, which means the followers turn with the dancer, but wait for them to turn so they can face the dancers head or they are simply too slow to stay in a perpendicular configuration.

### Motion Dynamics

Besides relative measures that investigate the relation of dancer and follower it is straightforward to compute the motion dynamics of the followers in natural and robotic dances. The target functions are the forward, sideward and angular velocities of a follower. This data has been extracted from 42 and 70 following runs (including each two waggles) from robotic and natural dances, respectively. Each sequence *waggle – return – waggle – return* with the first waggle being a right waggle (i.e. the dancer turns clockwise into the return run) was resampled to an equal number of samples (500 in the present study). For all 42 robotic and 70 reference sequences the mean was computed. Figure 60 depicts the results. For the sideward and angular velocities the robotic dance following is resembling closely the reference data. The forward velocities of followers in robotic dances differ shortly after the waggle runs (after 10% and 60% of the time the dancer initiates the first and second return run, respectively).

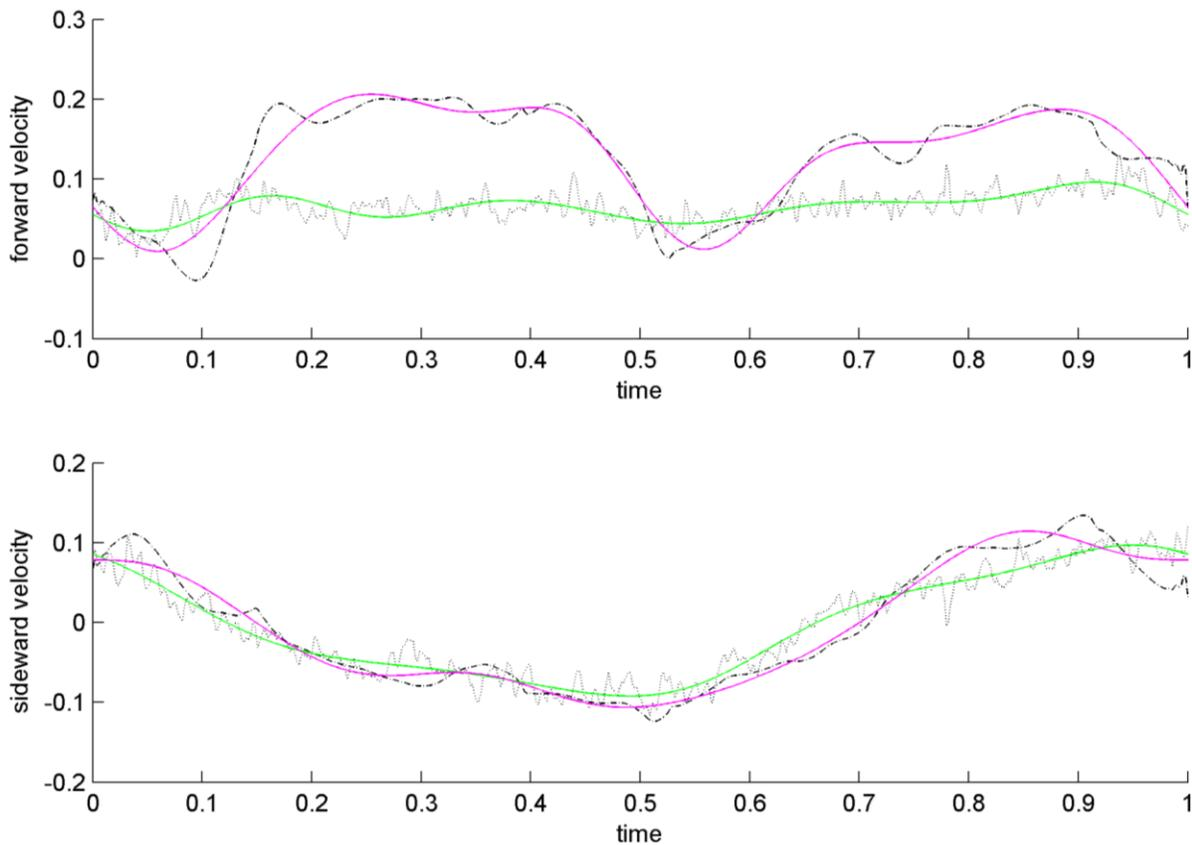

Figure 60: Mean forward and sideward velocities of followers in robotic dances (dash-dotted black line) and natural dances (dotted black line). The magenta and green lines depict spline interpolations for the robotic scenario and for natural dances, respectively.

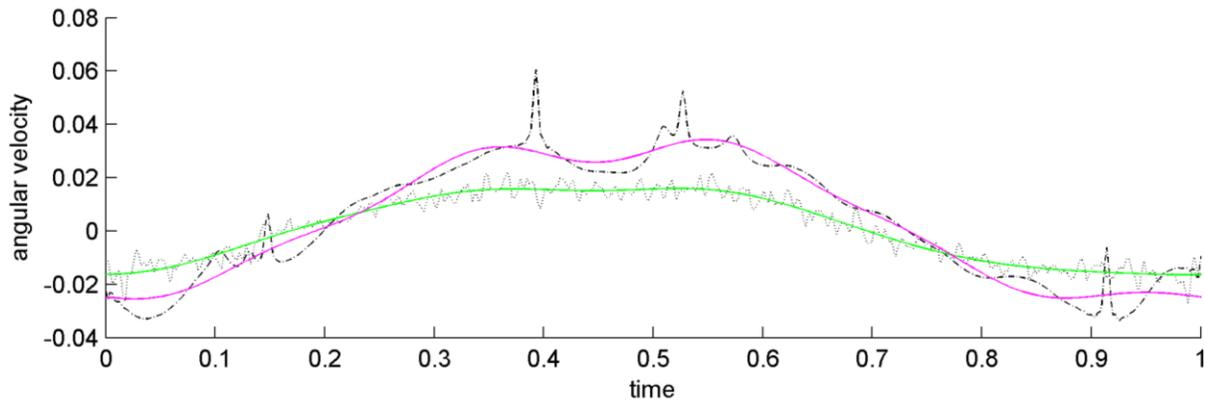

Figure 61: Mean angular velocities of followers in robotic dances (dash-dotted black line) and natural dances (dotted black line). The magenta and green lines depict spline interpolations for the robotic scenario and for natural dances, respectively.

### Average Dance Following Trajectory

However, by integrating the three velocities to a following trajectory the mean following shape can be visualized for both groups (see Figure 62). A follower describes a very stereotypical pendulum-like motion through a complete dance cycle (two consecutive waggle phases with return runs) that resembles the figure “8”. The waggle phase is sampled by moving outwards and turning into a right angle, starting from a “head-to-head” configuration (see Figure 59, subfigures 5 and 6). After the waggle phase, the body of the follower is oriented towards the center of the “8”. While the dancer is turning into the next waggle run, the follower describes the left arc, continuing through the waggle symmetrically to the previously described one.

### RADAR TRACES

Only a small number of followers were number-tagged and could therefore potentially carry a radar transponder. We were able to track five flights of different individuals that followed robotic dances and actually went on a foraging trip. A number of controls, i.e. bees that did not follow the robot at all or had only little contact with it, were tracked as well. Table 6 shows the complete list of animals that had record to follow and were traced in the flight. From the six marked animals that showed following behavior only four could be caught and fitted with a transponder. Two of those bees (ng62 and ng71) were following dances extensively that pointed to feeding sites they did not know yet. Ng62 had experienced feeder A only and followed 31 waggle runs pointing to Feeder B (60 degrees from FA). The radar tracks show that she first flies to the unknown location, turns towards FC - away from FA, flies a 180° turn of about 130 m distance and finally visits FA, the location she had been foraging on the previous day. After a short search, she returns to the hive where she was caught and released after having the transponder removed.

Conversely, bee ng71 had experienced feeder B the day before the test. She followed 47 waggle runs pointing to a virtual feeder (FC). On the first 100 m of her outbound trip she flies approximately towards the center point between FC and FB. She then seems to “converge” to Feeder B, where nothing could be found. She then starts a long search trip outside the observable boundaries and comes back after several hours.

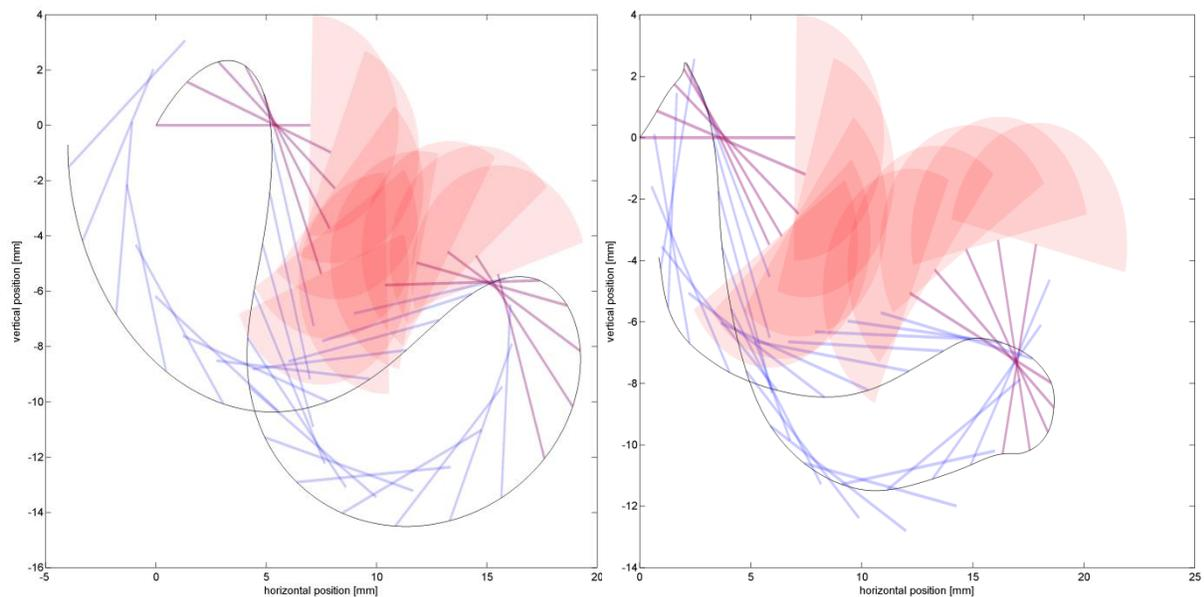

**Figure 62: Mean following path of followers of natural dances (left plot) and robotic dances (right plot). The black line depicts the positions of the body center. Blue lines depict the body orientation. In the waggle phases semi-circles depict the range followers can move their antenna in. Both trajectories start at (0,0) with a 0° orientation. Generally, the shape of both trajectories resembles an eight. The antenna-ranges overlap in the center of the eight – this is where the waggle runs are performed by natural or robotic dancers. The follower bee samples the right waggle run from the dancer’s left side and vice versa. The mean dance direction points towards the center of the “8”. Note that the follower’s path is symmetric but does not exhibit full 360°-turns like the dancer’s**

Another intriguing protocol is available for two individuals: bee ny18 was a very experienced forager. She had records for feeding from both sites FA and FB. She visited feeder B on the 26<sup>th</sup>, 30<sup>th</sup>, 31<sup>st</sup> of August and feeder A only once on the 31<sup>st</sup> of August. On that day both feeders were open; FA from 10:00 to 12:00 and in the evening from 17:00 to 18:30 FB only. Ny18 followed the whole day on September 3<sup>rd</sup>. She first showed light interest (sampling only some waggles, without motivated following behavior). The flight at 14:00 goes directly to feeder B, the robot pointing to FA. Prior to her second flight at 16:29 she followed 14 waggle runs with high motivation. This time she follows the robot’s dance direction and visits feeder A. At 16:55 she shows a high motivation to decode the dance. I switched the dance direction to feeder B. The bee follows 29 waggle run (twice as much as before) and flies to feeder B, then south to feeder A and then home again. She did not land at the hive (thus wasn’t caught) and flies out again, describing a broad loop over feeder B, returning home eventually.

A bee that showed less interest in the robot was ny47. She showed up near the robot regularly but her motivation to follow could not be excited before 11:48. She follows three waggle runs and does not continue. Although she occasionally comes near the robot and has antennal contact to the waggle (several times single waggles) she does not run out before 14:29. The radar track shows her visiting the previously visited location FA, the robot indicating FB. Later the same day she follows 5 more waggle runs but could not be traced again. Two days later, she could be caught again having followed no waggle. Radar traces show she visits FA again. The same happened the next day: no waggles followed, she visits the previously rewarded site. Figure 64 shows the tracks of ny18 and ny47. All radar plots were produced by Andreas Kirbach and are published in (Landgraf, et al., in prep.).

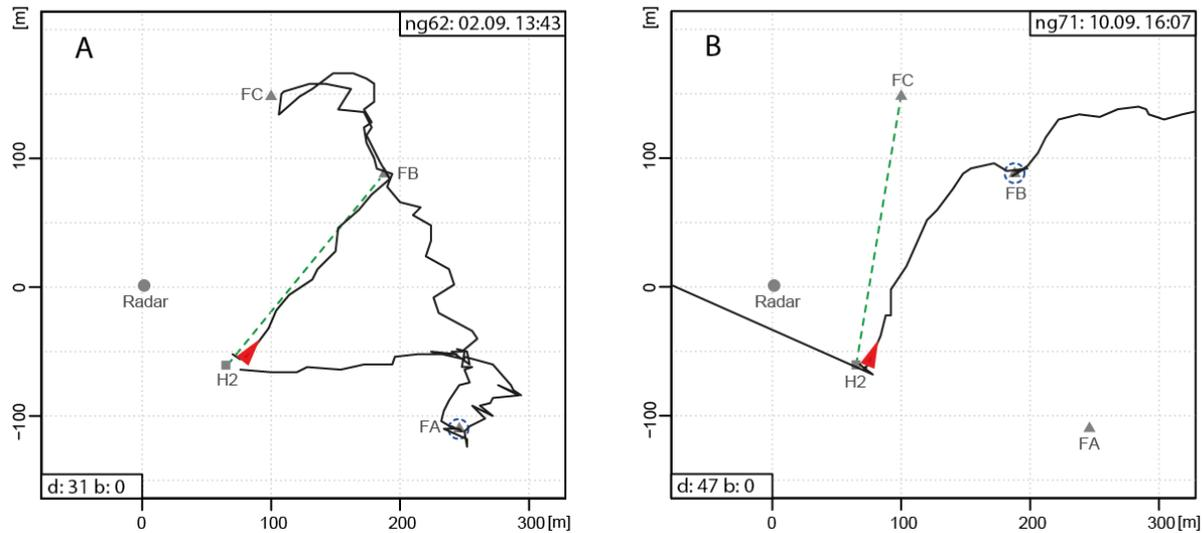

**Figure 63:** Flight paths are depicted as a black line, starting at the red triangle. Feeders marked with a rectangle have been reinforced at least once in preceding days. Feeders marked with a circle mark the last location that was visited and rewarded. In each subfigure the ID of the individual and time of flight are given in the upper right corner. The number of waggle runs followed right before the flight (d) and the accumulated number of waggle runs followed all days before (b) are given in the box to the lower right. Figure published in (Landgraf, et al., in prep.).

## DISCUSSION

A high number of individuals could be trained to either one or both feeders. Once the training was established for both feeders, the proportion of bees that knew both feeders decreased over time since new recruits mostly visit the feeder that was communicated in dances of trained foragers. Foragers furthermore do not switch feeding sites quickly (although they might do so after some days of having not experienced reward at the known feeding site under presence of dances). For the experiment there are hence four levels of experience of individuals that may have had contact with the robotic dance:

1. Bees that do not have experienced any of the two feeding sites
2. Bees that experienced only FA
3. Bees that experienced only FB
4. Bees that experienced both feeders

For a specific robotic dance that points to one of the two existing sites (apart from the virtual site “FC”) those 4 groups melt down to three:

1. Fully naïve bees
2. Bees naïve for the location but not for the food quality (sugar and concentration)
3. Experienced bees

It is likely that the following behavior depends on the previous experience. The forager might follow a different amount of waggle cycles or with a different degree of interest depending on the experience with the robot, the reward within the hive or at the feeding location. It is unknown and subject to future works which factors shape the gestalt of the following.

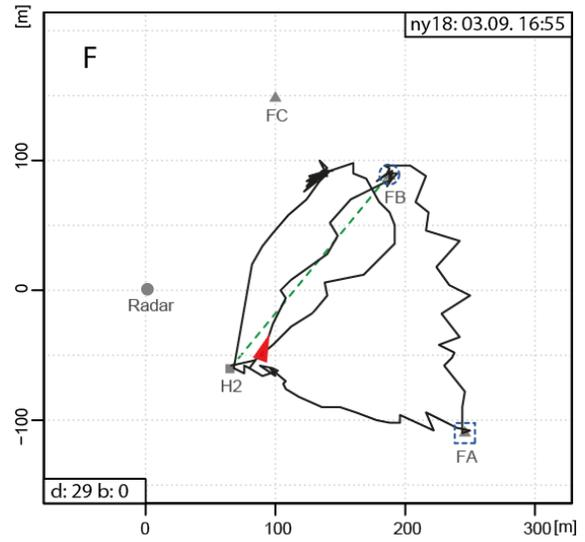
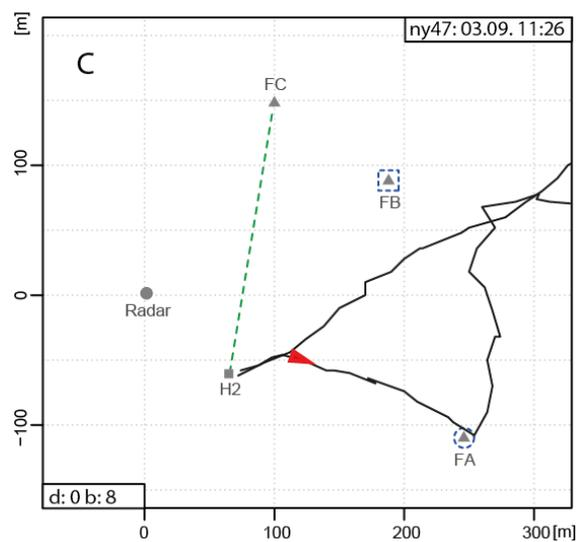
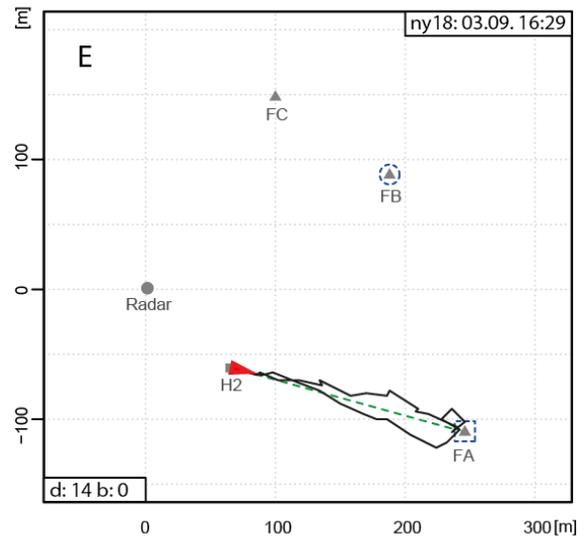
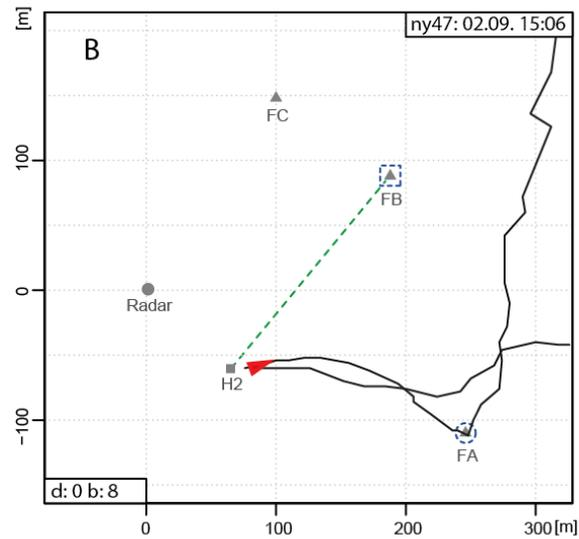
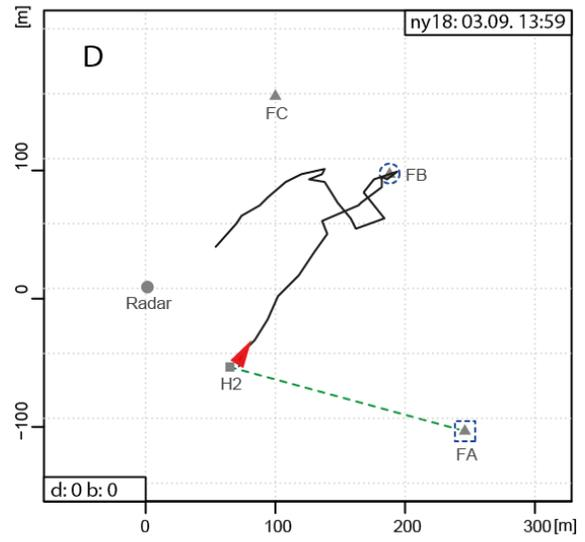
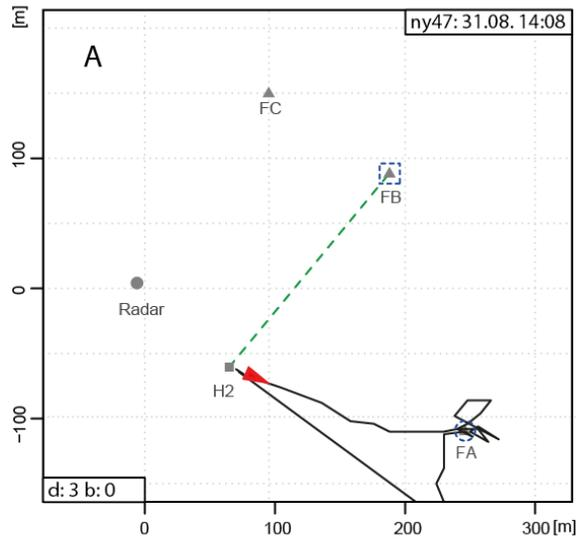

Figure 64: Radar tracks of flights of bees with various levels of experience with robotic dances. Subfigures A-C depict the flight paths of bee "ny47" who, although having accumulated a high number of waggle runs sampled, never showed highly motivated following behavior with the typical shape. Her outward vector flights point to feeder A, irrespective of the robotic dance that pointed to FB or FC. Bee ny18 was traced as control bee before having followed waggle runs. Throughout the day, she becomes very interested in the robot and shows a high number of motivated following runs. She subsequently visits the location indicated in the dance, ignoring her previous experience. Flight paths are depicted as a black line, starting at the red triangle. Feeders marked with a rectangle have been reinforced at least once in preceding days. Feeders marked with a circle mark the last visited and rewarded location. In each subfigure the ID of the individual and time of flight are given in the upper right corner. The number of waggle runs followed right before the flight ( $d$ ) and the accumulated number of waggle runs followed all days before ( $b$ ) are given in the box to the lower right. Figures published in (Landgraf, et al., in prep.).

### FREQUENCY AND DYNAMICS OF DANCE FOLLOWING BEHAVIOR

The following behavior was counted in video recordings of robotic and natural dances and a comparison was made between the two populations. The number of continuously followed waggle runs is higher in robotic dances. However, the robot was followed by mostly one animal at a time. There are only two recordings with two animals following the robot for more than 3 waggle runs. In natural dances, this is more often the case. Here, 2 or 3 simultaneous followers can be found relatively often. Likely, more bees are attracted by natural dances and, once excited to follow a dance; they actively push themselves into the desired position near the sides of the dancer and often push others out of their way. Consistently, I counted more short following behaviors; the whole distribution is narrower and shifted to the left in natural following.

Circa 32 % of the following runs observed in video recordings were performed by marked bees, in total only 6 individuals. If the same proportion holds true for the unmarked bees approximately 13 bees might account for the rest of the recorded following behavior. In the experiment, I often stopped the robot when an unmarked bee displayed the following behavior – we were interested in tracking flights - so actually this portion could have been even larger. Still, this number is considerably low. Natural dances seem to attract more bees at a time. However, even for natural dances it is unknown how many different individuals (whether experienced or naïve for the dance content) follow an arbitrary dance. It is thus not possible to quantify the low attractiveness of the robot.

Conversely, bees that once were excited to follow were very likely to follow again, even days later. It is unclear what determines the choice to follow a dance. The communicated profitability seems to be a good predictor for the attractiveness of a dance. (Seeley, et al., 2000) describes the waggle production rate (the number of waggles per time) and the dance duration as dance properties highly correlating with the sugar concentration of an artificial food source. Irrespective of the profitability, long dances naturally address more individuals and therefore even with a low attractiveness might excite more bees to follow. In natural dances, Seeley reported a median duration of 6 waggle runs and 90% of all dances having less than 27 waggle runs. However, in the robot experiments dances had long durations. Typically, I had the robot continuously perform a dance for up to 5 minutes, followed by a break of a few minutes. After a dance session of half up to 30 minutes I would either stop the robot for a longer break (when no following behavior was observable) or continue dancing. This sequence was iterated for a few hours per day. The waggle production rate, i.e. the number of waggles per second, was set to 0.35. Seeley et al. (2000) reports rates of around 0.5 waggles per second for a  $2.5 \text{ mol l}^{-1}$  feeder 350 m away. The mean duration for one return run was found to be only 1.26 s in lively waggle dances as opposed to the mean return run duration of 2.1 s used for the robotic dances as defined in (Landgraf, et al., 2011). It is unclear whether the profitability of a food source can vary based on the general food availability in the environment and the hive's storage. However, the low number of followers might be explained by the choice of the dance parameters.

Still, once the robot has caught the attention of a follower the mean number of continuously followed waggles is even higher than under natural conditions. Since I did not mark enough followers in both setups, it is unknown how many waggles a follower would sample in total, i.e. with interruptions. However, bees can fly out after only a

few waggles followed. Menzel et al. (2011) reports bees flying according to the social (dance) information when having followed around 20 waggles. Those levels are reached for a few individuals in robotic dances as well.

Following less than 3 waggles occurs often. For the analysis, the threshold of 3 was chosen to leave out bees that by chance might have sampled a waggle run or those that display only partial interest. The latter group often follows the sequence *waggle – return – waggle* and then seems to get distracted or uninterested in the last return run. On the other hand, some bees did show vital interest in the robot – without following more than 2 consecutive waggle runs; but those are rare. When a bee continues to follow until the third waggle run, she is very likely to follow more. Also on the level of the body motion there is a difference between bees that show high interest and follow many waggle runs and those bees that display a lower excitement to follow the dance. The latter group might sample the waggle from all possible locations around the dancer. Highly interested bees seem anxious for staying at the sides of the dancer and move in a stereotypical pattern. By excluding short following behaviors the analysis focuses on those highly motivated followers.

The following behavior was observed only after many days of using the robot. No apparent changes to the design or functionality were made that might have caused this shift. Many replicas were tested among which the previously described replicas made from sponge and plastic foil were accepted the best. Still the following behavior was observed only days after the replicas were replaced. On the other hand, the following behavior did not cease after replacing the replica (built from the same material though). It remains unknown what determined the shift of responsiveness towards the robot. Since internal parameters remained unchanged it may have been environmental parameters (food availability in the field and the hive, food requirements) that caused it. There exists some evidence that bees tend to follow dances of their super-sisters (Oldroyd, et al., 1991). However, it remains untested if an “odor-camouflage” for a certain patriline improves the frequency with which the robot dances are followed. Future analyses will focus on the question what distinguishes those bees that followed the robot from those that did not.

The analysis of the motion dynamics of the following behavior provides evidence that followers move similarly with the robot compared to natural dance followers. Interested bees follow similarly close and in a similar relative angle. The average trajectory of bees following the robot resembles closely the average path of natural followers. The only difference can be found in the forward velocity of dance followers in return runs. This could be explained by the fact that natural dancers exhibit a higher variability of their forward motion velocities – they sometimes even stop the run completely which has an effect on the forward velocity of the followers. The robot in contrast describes a smooth trajectory and the followers might have to run faster to keep in contact with it which is reflected by the increased forward velocity.

Assuming that dance following expresses the process of decoding the message, it is likely that robot followers were trying to decode the robotic dance. Given the similarity of the imitated stimuli, it is therefore likely that those followers – at least partially – decoded the message.

### RADAR TRACES

The number of recorded radar flights of bees having followed a robotic dance is too low for a clear assertion. However, for those animals the results are consistent with previous experimental evidence of natural dance communication. Throughout three days, bee 47 follows only a few waggle runs and never visits the announced location. Bee 18 starts as a control bee and flies out to the previously rewarded location. After following the robot a number of times - once congruent with her previous experience, thereafter the other direction – she obeys the robots indications. However, this is no evidence. Bee 18 might have checked feeder B based on a decision independent of her experiences with robotic dances – an even likely explanation. However, two bees were naïve

for the announced directions. Only one bee was observed to fly to the indicated location after having followed 31 waggle runs. The other bee, having followed 47 waggle runs indicating a virtual feeder, visits a previously experienced location. Her flight starts into the dance indicated direction, but soon converges to the 30 degrees distant known location.

With more data it would be possible to actually test for a transfer of information. However, these have to be collected in future experiments.

## **5.6 CONCLUSIONS**

In this chapter I describe experiments throughout three consecutive years. The results were used to improve the robot's design after every summer. The first experiments were conducted to support the choice for certain body materials and treatments with experimental evidence. As a result, the final body of RoboBee was made out of soft sponge wrapped in plastic foil. This combination ensures optimal passive compliance and chemical neutrality. The bodies are coated with a thin layer of wax and put in the colony to acquire the hive's scent. This yields very low disturbance of surrounding animals when inserted in the hive.

In follow-up experiments, the ability of the robot to recruit bees was investigated. As a prerequisite to recruitment, the stereo-typical following behavior represents a quality of robot to honeybee interaction that has never been reported before. In experimental trials in the year 2010 this behavior could not be excited. However, I collected experimental evidence that recruitment might well be excited in two stages: First, the foraging motivation is activated and second, the actual direction and distance information is communicated. The results of the experiments in 2010 indicate that the wing vibrations are involved in exciting the foraging motivation – a result that is supported by reports on silent dances. The recruitment of naïve bees, however, requires an active decoding process, likely expressed by the dance following behavior.

Changes in the robot's design could excite this behavior in the summer experiments of 2011. Many individuals followed the robotic dance as if it were natural ones. Statistical motion analyses confirm this. The animals that followed the robot extensively - and therewith showed a high interest in the contained message - actually flew to the communicated target as depicted in the radar traces. However, the number of animals tracked in flight is still too low to make an assertion about the ability of the robot to recruit bees. Still, this dissertation provides the first record of following behavior and compares it thoroughly with natural following. Since the resemblance is very high it is likely that information was decoded by those animals. Further experiments will address the ability to attract more bees to follow and increase the number of flight traces of recruits.

# CONCLUSIONS AND FUTURE WORK

What has been accomplished, Prospects, new Experiments and Tools

## 6.1 CONCLUSIONS

This dissertation provides a complete insight of my approach to building a honeybee robot. Starting with a thorough analysis of the state-of-the-art views in the field of honeybee dance communication and previous systems similar to the one presented, I meticulously analyzed the dancer; i.e. the sender in the communication system. I traced dance movements, described distinct motion features and important aspects of the dance and used this analysis to propose a dance model for the robot's movements. This analysis is unique in its richness of detail; no study before used such high degree of temporal and spatial resolution. To my knowledge, a model of the waggle dance has not been described before.

Subsequently, I reviewed all stimuli and possible signals in the process and investigated their prospective roles in the biological system. Based on this thorough review, I designed and constructed a robot in a few iterations; each loop fed back with information gained from experiments. A comparison to Michelsen's robot is not straight forward since their data (motion model, video recordings, etc.) is not available, or doesn't exist. However, our honeybee robot can be assumed to dance more realistically: RoboBee does not get stung because it uses a fast computer vision sensor for obstacle recognition and can easily be controlled manually with different handy devices. The robot is accepted and can run for hours in the hive without disturbing the colony. Moreover, the dances are followed extensively and in a natural manner by potential recruits. This behavior has not been reported to happen with any other honeybee robot. This indicates that all previous systems and especially Michelsen's robot (as reported in (Michelsen, et al., 1992) ) might have "only" reactivated the animals' foraging motivation as shown in Chapter 5: Recruitment Experiments, 2010. As far as the dance communication is understood, it may be considered unlikely that recruitment of naïve bees could have been successful without any following behavior. RoboBee has advanced the capabilities of previous robots and reached an important state of interaction quality.

The analysis of the way how bees interact with the robotic bee, the way how they follow its circles is another contribution of the thesis as it is the first time this behavior was reported and recorded. I first describe how bees follow natural dances. This reference is compared to the trajectories of bees that follow the robot. The results show that there is virtually no difference in the way they move. Those followers pursue the dancer equally persistently as natural dances are followed.

Secondary contributions are the computer vision program developed for the video analysis and hundreds of Gigabytes of video recordings that will be shared with the public. I used the program to track natural and robotic dancers and their followers. The executable is available in the dissertation's repository<sup>9</sup>. The videos that I recorded

---

<sup>9</sup> [www.robobee.eu/dissertation/landgraf](http://www.robobee.eu/dissertation/landgraf)

will be made available with the trajectories of dancers and followers in collaboration with Prof. Jürgen Tautz on [www.hobos.de](http://www.hobos.de).

## **6.2 FUTURE WORK, NEW TOOLS**

The final proof whether the robot can or cannot recruit naïve bees to a remote location could not be given. The flight tracks concordant with the dance information are too few in number to make a statistically significant assertion. The development of the robot, as the intended tool for the analysis of the dance communication, however, is finished. Now the biological work should be put into focus. Still, this tool should be improved using new findings that will be revealed using it.

### **6.2.1 BEE FACEBOOK**

An example may be put forward by the last year's experiments: The following behavior is found to be rare and our understanding as to why it is sometimes triggered remains limited. What discriminates those bees that do follow from those that do not? What do those that follow have in common? Do they differ in age? Do they have similar foraging experience? Do they share the same patriline? Those questions emerge from the experiments with the robot and might be solved using it as well. I am planning to investigate this very question using "conventional" methods first. I will conduct an experiment with a fully tagged hive (with approx. 2000 bees). High resolution cameras will record a one-frame observation hive from both sides and a computer vision program will locate and identify every bee. All images will be automatically evaluated to find out with whom bees are sharing certain activities (dancing, dance following, etc.) in a local neighborhood. For example, some bees might follow the same dances in the same place on the comb. Is this relationship preserved over time? Could this explain why the robot was followed only by a few bees but those followed very similarly to natural dances (in trajectory and number of dance cycles)? Controlling and/or recording certain properties of each bee (patriline, age, forage, etc.) might reveal which factors determine the formation of peer groups. Once those factors are identified the robot will be used to test those hypotheses.

### **6.2.2 SYSTEMATICALLY VARYING PARAMETERS OF THE DANCE**

The following behavior is the most obvious positive behavior foragers can display with the robot in the hive. Further experiments in conjunction with the radar tracking will be conducted to test the effect of varying certain parameters of the dance on the following behavior. Foremost changing those properties that express food source profitability, even out of naturally feasible limits, (like the waggle run production rate) will be investigated in future experiments since they might directly result in a change of the readiness to follow or the frequency and duration of the behavior.

### **6.2.3 CHARACTERIZATION OF VIBRATIONAL SIGNALS**

A few years ago I started to develop a system (together with Uwe Greggers and Taner Topal) that was never finished but might reveal the communication dynamics of vibrational signals in the dance context. So far, only the dancer's vibrational signals were addressed and investigated. But even without dances a lot of vibrational signals can be recorded (see Chapter 3). With a grid of operational amplifiers built into the comb it is possible to record and localize electric fields produced by any bee (sample data available on request). Each buzz could be allocated to an individual and its behavior by recording a synchronized video. I believe it is desirable to characterize the vibrational repertoire of followers and dancer throughout many waggle phases and correlate the behavior or behavioral changes to the production and reception sequence of vibrational signals.

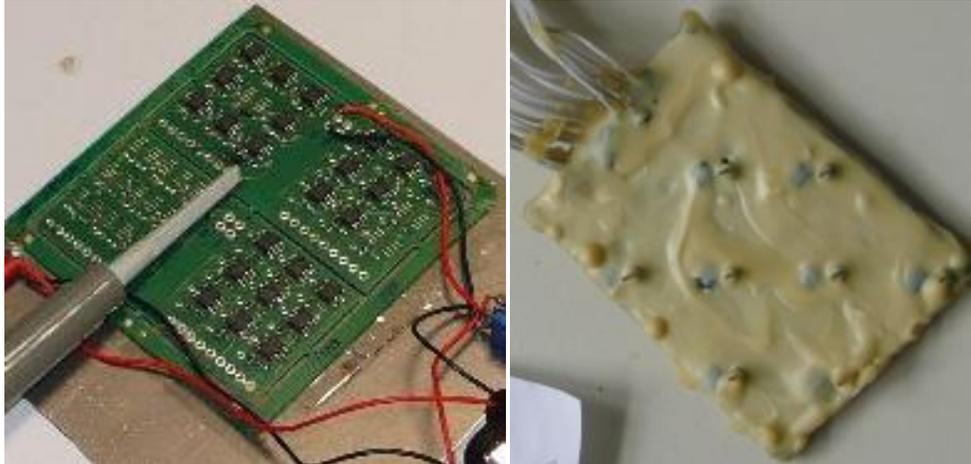

Figure 65, left: The first prototype of an array of operational amplifiers used for localizing electric fields produced by bees. The circuit board shown in the photograph integrates three different matrices of 3 x 3 amplifiers working with different amplification levels (determined by the use of different resistors on the back side of the board). Right image: in the second prototype the amplifiers were arranged in a diagonal pattern. The board was coated and fitted into a honey comb which was put in a live colony.

#### 6.2.4 ROBOBEE AND ROBOBEE 2.0

Michelsen's work on his robot ceased suddenly in the early 1990's. RoboBee might end up in a storage unit as well because the funding and/or the appropriate personnel might not be available. I would love to share the experience with Robobee, the construction plans and the software to operate it in order to prevent this from happening. I would be happy to help constructing many more RoboBees or borrow the one that we have to interested researchers for their lines of research – if I wouldn't be able to use it. I already have plans for a new version of the robot that would be coupled magnetically to the outside. The control of the motion would still be implemented by an external positioning device non-invasively.

I am aware that using a robot for the investigation of social behavior might be prone to fail because of many technical difficulties. I nonetheless believe that, once those difficulties are overcome, it will be tools like RoboBee that will help solving many open questions, even those that lasted for 60 years – or more - eventually.

### 6.3 SUMMARY OF CONTRIBUTIONS

This doctoral thesis makes three major contributions:

First, the analysis of waggle dances using a computer vision program and an automatic variance analysis has not been performed before. The proposed tracking algorithm is independent of the visual appearance of the bee, can be used with different recording qualities and is robust under varying lighting conditions. The extracted dance trajectories describe the body motion of dancers in high temporal and spatial detail. The subsequent analysis yields a detailed list of dance properties including their variability. Using these properties I propose a realistic computer model of the dance that is used for the robotic imitations of the waggle dance. The results and data of this analysis, i.e. the video recordings, the tracking program, the trajectories and the source code of the dance model will be made accessible for the general public.

The robotic dancer is the second contribution of this thesis. The proposed system is able to move a bee replica in a Cartesian coordinate frame, reproduce the waggle dance with realistic imitations of natural stimuli such as wing vibrations, sugar samples, the body scent and body heat. The robot can react on its environment. It evades or softens collisions by reducing the motion velocity prior to an anticipated impact. It can also provide food samples

automatically when animals are detected near the head or decreases the waggle amplitude when individuals come too close to the wagging abdomen. RoboBee is the first honeybee robot that can be operated in a closed control loop.

The third contribution is the series of recruitment experiments in which I find that the robot not only motivates bees to forage at their previously visited sites. For the first time a honeybee robot also excites extensive following behavior, a clear indicator that those individuals try to decode the robotic dance. In a detailed comparison of robotic following and natural following behavior I give evidence that both are equivalent. The analysis, similar to the visual analysis of the dance, is based on motion data that is unique. Never before has the dance following behavior been described on such detailed level. Also this data, the trajectories of dance followers will be made available to the public.

## 7 BIBLIOGRAPHY

- Beekman M and Lew J B** Foraging in honeybees: when does it pay to dance? *Behavioral Ecology*. ISBE, 2008. - Vol. 19. - pp. 255--261.
- Beekman M, Doyen L and Oldroyd B** Increase in dance imprecision with decreasing foraging distance in the honey bee *Apis mellifera* L. is partly explained by physical constraints *Journal of Comparative Physiology A: Neuroethology, Sensory, Neural, and Behavioral Physiology*. - dec 2005. - Vol. 191. - pp. 1107--1113.
- Biesmeijer J and Seeley T** The use of waggle dance information by honey bees throughout their foraging careers *Behavioral Ecology and Sociobiology*. - nov 2005. - Vol. 59. - pp. 133--142.
- Bisetzky A R** Die Tänze der Bienen nach einem Fussweg zum Futterplatz *Journal of Comparative Physiology A: Neuroethology, Sensory, Neural, and Behavioral Physiology*. Springer, 1957. - Vol. 40. - pp. 264--288.
- Bitterman M E, Menzel R, Fietz A, Schäfer S** Classical conditioning of proboscis extension in honeybees (*Apis mellifera*). *Journal of Comparative Psychology*. American Psychological Association, 1983. - Vol. 97. - p. 107.
- Bohlen M** A robot in a cage-exploring interactions between animals and robots. - 1999. - pp. 214--219.
- Bozic J and Valentincic T** Attendants and followers of honeybee waggle dances *J Apic Res*. - 1991.
- Breed M D and Julian G E** Do simple rules apply in honey-bee nestmate discrimination? *Nature*. - jun 1992. - Vol. 357. - pp. 685--686.
- Breed M D** Recognition Pheromones of the Honey Bee *BioScience*. American Institute of Biological Sciences, 1998. - Vol. 48. - pp. 463--470. - 00063568.
- Cootes T F, Edwards G J and Taylor C J** Active appearance models *Pattern Analysis and Machine Intelligence, IEEE Transactions on*. IEEE, 2001. - Vol. 23. - pp. 681--685.
- De Marco R and Menzel R** Learning and memory in communication and navigation in insects *Learning and Memory-A Comprehensive Reference*. - 2008. - Vol. 1.
- De Marco R and Menzel R** Encoding spatial information in the waggle dance *J Exp Biol*. - 2005. - Vol. 208. - pp. 3885-3894.
- De Marco R J, Gurevitz J M and Menzel R** Variability in the encoding of spatial information by dancing bees *J Exp Biol*. - may 2008. - Vol. 211. - pp. 1635--1644.
- Dìaz P C, Grüter C and Farina W M** Floral scents affect the distribution of hive bees around dancers *Behavioral Ecology and Sociobiology*. Springer, 2007. - Vol. 61. - pp. 1589--1597.
- Dreller C and Kirchner W H** Hearing in honeybees: localization of the auditory sense organ *Journal of Comparative Physiology A: Neuroethology, Sensory, Neural, and Behavioral Physiology*. - sep 1993. - Vol. 173. - pp. 275--279.
- Dreller C** Mechanismen der Informationsübertragung in der Tanzsprache der Honigbienen [Report] : phdthesis. - 1993.
- Dyer F C** The biology of the dance language *Annual Review of Entomology*. - 2002. - Vol. 47. - pp. 917-949.

- Edrich W** Interaction of light and gravity in the orientation of the waggle dance of honey bees *Animal Behaviour*. - 1977. - Vol. 25. - pp. 342 - 363. - 0003-3472.
- Edwards G J, Taylor C J and Cootes T F** Learning to identify and track faces in image sequences. - 1998. - pp. 260--265.
- Esch H E and Burns J E** Distance estimation by foraging honeybees *J. Exp. Biol.* - 1996.
- Esch H E and Burns J E** Honeybees use optic flow to measure the distance of a food source *Naturwissenschaften*. - 1995.
- Esch H** The sounds produced by swarming honey bees *Z. vergl. Physiol.* - 1967.
- Esch H** Beiträge zum Problem der Entfernungsweisung in den Schwänzeltänzen der Honigbiene *Journal of Comparative Physiology A: Neuroethology, Sensory, Neural, and Behavioral Physiology*. - sep 1964. - Vol. 48. - pp. 534--546.
- Esch H** Über die Körpertemperaturen und den Wärmehaushalt von *Apis mellifica* *Journal of Comparative Physiology A: Neuroethology, Sensory, Neural, and Behavioral Physiology*. - may 1960. - Vol. 43. - pp. 305--335.
- Esch H** Über die Schallerzeugung beim Werbetanz der Honigbiene *Journal of Comparative Physiology A: Neuroethology, Sensory, Neural, and Behavioral Physiology*. - jan 1961. - Vol. 45. - pp. 1--11.
- Esch H, Esch I and Kerr W E** Sound: An Element Common to Communication of Stingless Bees and to Dances of the Honey Bee *Science*. - 1965. - Vol. 149. - pp. 320-321.
- Faria J J, Dyer J, Clément R, Couzin I, Holt N, Ward A, Waters D, Kause J** A novel method for investigating the collective behaviour of fish: introducing 'Robofish' *Behavioral Ecology and Sociobiology*. Springer, 0 0, 2010. - Vol. 64. - pp. 1211--1218.
- Farina W M, Grüter C and Diaz P C** Social learning of floral odours inside the honeybee hive *Proceedings of the Royal Society B: Biological Sciences*. - sep 2005. - Vol. 272. - pp. 1923--1928.
- Fernandez-Juricic E, Gilak N, Mcdonald C J, Pithia P, Valcarcel A** A dynamic method to study the transmission of social foraging information in flocks using robots *Animal behaviour*. Elsevier, 2006. - Vol. 71. - pp. 901--911.
- Fischler M A and Bolles R C** Random sample consensus: a paradigm for model fitting with applications to image analysis and automated cartography *Communications of the ACM*. ACM, 1981. - Vol. 24. - pp. 381--395.
- Frisch K v** Die Tänze der Bienen *Österreich. Zool. Z.* - 1946. - Vol. 1. - pp. 1--48.
- Frisch K v** *Tanzsprache und Orientierung der Bienen* [Book]. Springer-Verlag, Berlin, 1965.
- Fröhlich B, Riederer M and Tautz J** Comb-wax discrimination by honeybees tested with the proboscis extension reflex *J Exp Biol*. - 2000. - Vol. 203. - pp. 1581-1587.
- Gil M** Decoding information in the honeybee dance: revisiting the tactile hypothesis *Animal Behaviour*. - 2010. - Vol. 80. - pp. 887 - 894. - 0003-3472.

- Göth A and Evans C S** Social responses without early experience: Australian brush-turkey chicks use specific visual cues to aggregate with conspecifics *Journal of experimental biology*. The Company of Biologists Ltd, 2004. - Vol. 207. - pp. 2199--2208.
- Gould J L** Honey bee recruitment: the dance-language controversy *Science*. - 1975.
- Greggers U, Koch G, Schmidt V, Dürr A, Floriou-Servou A, Piepenbrock D, Göpfert MC, Menzel R.** Reception and learning of electric fields in honeybees *Proceedings of the Royal Society B*. - 2013.
- Gribovskiy A, Halloy J, Deneubourg J L, Bleuler H, Mondada F** Towards mixed societies of chickens and robots. - 2010. - pp. 4722--4728.
- Grüter C and Ratnieks F L** Honeybee foragers increase the use of waggle dance information when private information becomes unrewarding *Animal Behaviour*. Elsevier, 2011. - Vol. 81. - pp. 949--954.
- Grüter C, Balbuena M and Farina W M** Informational conflicts created by the waggle dance *Proceedings of the Royal Society B: Biological Sciences*. The Royal Society, 2008. - Vol. 275. - pp. 1321--1327.
- Grüter C and Farina W M** The honeybee waggle dance: can we follow the steps? *Trends in Ecology & Evolution*. - 2009. - Vol. 24. - pp. 242 - 247. - 0169-5347.
- Haldane J B and Spurway H** A statistical analysis of communication in *Apis mellifera* and a comparison with communication in other animals *Insectes Sociaux*. Springer, 1954. - Vol. 1. - pp. 247--283.
- Haldane J B** The future of biology *Possible Worlds*. - 1927. - pp. 139--153.
- Halloy J, Sempo G, Caprari G, Rivault C, Deneubourg J L** Social Integration of Robots into Groups of Cockroaches to Control Self-Organized Choices *Science*. - 2007. - Vol. 318. - pp. 1155-1158.
- Heran H** Ein Beitrag zur Frage nach der Wahrnehmungsgrundlage der Entfernungsweisung der Bienen (*Apis mellifica* L.) *Journal of Comparative Physiology A: Neuroethology, Sensory, Neural, and Behavioral Physiology*. - jan 1956. - Vol. 38. - pp. 168--218.
- Hough P V** Method and means for recognizing complex patterns. Google Patents, dec # ~18 1962.
- Hussaini S A, Bogusch L, Landgraf T, Menzel R** Sleep deprivation affects extinction but not acquisition memory in honeybees *Learning & Memory*. - 2009. - Vol. 16. - pp. 698-705.
- Jensen I L, Michelsen A and Lindauer M** On the Directional Indications in the Round Dances of Honeybees *Naturwissenschaften*. - oct 1997. - Vol. 84. - pp. 452--454.
- Judd T M** The waggle dance of the honey bee: Which bees following a dancer successfully acquire the information? *Journal of Insect Behavior*. - may 1994. - Vol. 8. - pp. 343--354.
- Kalal Z, Matas J and Mikolajczyk K** Pn learning: Bootstrapping binary classifiers by structural constraints. - 2010. - pp. 49--56.
- Kirbach A** Navigation und Kommunikation von Honigbienen [Report]. - Berlin : Freie Universität Berlin, 2013.
- Kirchner W H** Acoustical communication in honeybees *Apidologie*. - 1993. - Vol. 24. - pp. 297-307.

- Kirchner W H and Towne W F** The sensory basis of the honeybees dance language *Sci Am.* - 1994.
- Kirchner W H** Vibrational signals in the tremble dance of the honeybee, *Apis mellifera* *Behavioral Ecology and Sociobiology.* Springer, 1993. - Vol. 33. - pp. 169--172.
- Kirchner W H, Lindauer M and Michelsen A** Honeybee dance communication *Naturwissenschaften.* - dec 1988. - Vol. 75. - pp. 629--630.
- Kirchner W H and Sommer K** The dance language of the honeybee mutant diminutive wings *Behavioral Ecology and Sociobiology.* - apr 1992. - Vol. 30. - pp. 181--184.
- Kirchner W H, Dreller C and Towne W F** Hearing in honeybees: operant conditioning and spontaneous reactions to airborne sound *Journal of Comparative Physiology A: Neuroethology, Sensory, Neural, and Behavioral Physiology.* - jan 1991. - Vol. 168. - pp. 85--89.
- Kubinyi E, Miklósi A, Kaplan F, Gácsi M, Topál J, Csányi V** Social behaviour of dogs encountering AIBO, an animal-like robot in a neutral and in a feeding situation *Behavioural processes.* Elsevier, 2004. - Vol. 65. - pp. 231--239.
- Landgraf T, Oertel M, Rhiel D, Rojas R** A biomimetic honeybee robot for the analysis of the honeybee dance communication system. - 2010. - pp. 3097--3102. - 2153-0858.
- Landgraf T, Rojas R, Nguyen H, Kriegel F, Stettin K** Analysis of the Waggle Dance Motion of Honeybees for the Design of a Biomimetic Honeybee Robot *PloS one.* Public Library of Science, 2011. - Vol. 6. - p. e21354.
- Landgraf T, Oertel M, Kirbach A, Menzel R, Rojas R** Imitation of the Honeybee Dance Communication System by Means of a Biomimetic Robot *Biomimetic and Biohybrid Systems.* Springer, 2012. - pp. 132--143.
- Landgraf T and Rojas R** Tracking honey bee dances from sparse optical flow fields [Report] : techreport. - 2007. - pp. 1-37.
- Landgraf T, Moballegh H and Rojas R** Design and development of a robotic bee for the analysis of honeybee dance communication *Applied Bionics and Biomechanics.* Taylor & Francis, 2008. - Vol. 5. - pp. 157--164.
- Landgraf T** Online Learning of Varying Appearances While Tracking Honeybees Dances. - in prep.
- Langstroth L L** A Practical Treatise on the Hive and Honey-bee. CM Saxton & Company, 1857.
- Lindauer M** Recent advances in bee communication and orientation *Annual Review of Entomology.* Annual Reviews 4139 El Camino Way, PO Box 10139, Palo Alto, CA 94303-0139, USA, 1967. - Vol. 12. - pp. 439--470. - 0066-4170.
- Lindauer M** The functional significance of the honeybee waggle dance *American Naturalist.* JSTOR, 1971. - pp. 89--96.
- Maeterlinck M** *The Life of the Bee* [Book]. Dodd, Mead and company, 1901.
- Martins E P, Ord T J and Davenport S W** Combining motions into complex displays: playbacks with a robotic lizard *Behavioral Ecology and Sociobiology.* Springer, 2005. - Vol. 58. - pp. 351--360.
- Mautz D** Der Kommunikationseffekt der Schwänzeltänze bei *Apis mellifica carnica* (Pollm.) *Journal of Comparative Physiology A: Neuroethology, Sensory, Neural, and Behavioral Physiology.* Springer, 1971. - Vol. 72. - pp. 197--220.

- Menzel R and Blakers M** Colour receptors in the bee eye—morphology and spectral sensitivity *Journal of Comparative Physiology A: Neuroethology, Sensory, Neural, and Behavioral Physiology*. Springer, 1976. - Vol. 108. - pp. 11--13.
- Menzel R, De Marco R J and Greggers U** Spatial memory, navigation and dance behaviour in *Apis mellifera* *Journal of Comparative Physiology A: Neuroethology, Sensory, Neural, and Behavioral Physiology*. - 2006. - Vol. 192. - pp. 889-903.
- Menzel R, Kirbach A, Haass WD, Fischer B, Fuchs J, Koblöfsky M, Lehmann K, Reiter L, Meyer H, Nguyen H, Jones S, Norton P, Greggers U** A Common Frame of Reference for Learned and Communicated Vectors in Honeybee Navigation *Curr Biol. Cell Press*, apr 2011. - Vol. 21. - pp. 645--650. - 0960-9822.
- Menzel R, Greggers U, Smith A, Berger S, Brandt R, Brunke S, Bundrock G, Hülse S, Plümpe T, Schaupp F, Schüttler E, Stach S, Stindt J, Stollhoff N, Watzl S** Honey bees navigate according to a map-like spatial memory. *Proceedings of the National Academy of Sciences*. - 2005. - Vol. 102. - pp. 3040-3045.
- Menzel R, Brandt R, Gumbert A, Komischke B, Kunze J** Two Spatial Memories for Honeybee Navigation *Proceedings: Biological Sciences. The Royal Society*, may 2000. - Vol. 267. - pp. 961--968.
- Michelsen A, Andersen B B, Kirchner W H, Lindauer M** Honeybees can be recruited by a mechanical model of a dancing bee *Naturwissenschaften* 76. - 1989.
- Michelsen A** Ein mechanisches Modell der tanzenden Honigbiene *Biologie in unserer Zeit*. WILEY-VCH Verlag GmbH, 1989.
- Michelsen A , Andersen B B, Kirchner W H, Lindauer M** How honeybees perceive communication dances, studied by means of a mechanical model *Behavioral Ecology and Sociobiology*. - apr 1992. - Vol. 30. - pp. 143--150.
- Michelsen A** Signals and flexibility in the dance communication of honeybees *Journal of Comparative Physiology A: Neuroethology, Sensory, Neural, and Behavioral Physiology*. - mar 2003. - Vol. 189. - pp. 165--174.
- Michelsen A, Kirchner W H and Lindauer M** Sound and vibrational signals in the dance language of the honeybee, *Apis mellifera* *Behavioral Ecology and Sociobiology*. - jan 1986. - Vol. 18. - pp. 207--212.
- Mikolajczyk K and Schmid C** A performance evaluation of local descriptors *Pattern Analysis and Machine Intelligence, IEEE Transactions on*. IEEE, 2005. - Vol. 27. - pp. 1615--1630.
- Nieh J C** The honey bee shaking signal: function and design of a modulatory communication signal *Behavioral Ecology and Sociobiology*. Springer, 1998. - Vol. 42. - pp. 23--36.
- Nieh J C** The stop signal of honey bees: reconsidering its message *Behavioral Ecology and Sociobiology*. - jul 1993. - Vol. 33. - pp. 51--56.
- Nieh J C and Tautz J** Behaviour-locked signal analysis reveals weak 200-300 Hz comb vibrations during the honeybee waggle dance *J Exp Biol*. - 2000. - Vol. 203. - pp. 1573-1579.
- Oertel M** Entwicklung und Aufbau eines biomimetischen Bienenroboters zur Erforschung des Bientanzes [Report]. - Berlin : Freie Universität Berlin, 2009.

- Ord T J and Stamps J A** Alert signals enhance animal communication in noisy environments Proceedings of the National Academy of Sciences. National Acad Sciences, 2008. - Vol. 105. - p. 18830.
- Partan S R, Larco C P and Owens M J** Wild tree squirrels respond with multisensory enhancement to conspecific robot alarm behaviour Animal Behaviour. Elsevier, 2009. - Vol. 77. - pp. 1127--1135.
- Patricelli G L, Uy J A C , Walsh G, Borgia G** Sexual selection: male displays adjusted to females response Nature. Nature Publishing Group, 2002. - Vol. 415. - pp. 279--280.
- Peirce C S, Hartshorne C and Weiss P** Collected Papers of Charles Sanders Peirce [Book]. Harvard University Press, 1935.
- Reaney L T , Sims R A, Sims S W M, Jennions M D, Backwell P R Y** Experiments with robots explain synchronized courtship in fiddler crabs Current Biology. Elsevier, 2008. - Vol. 18. - pp. R62--R63.
- Reaney L T** Female preference for male phenotypic traits in a fiddler crab: do females use absolute or comparative evaluation? Animal behaviour. Elsevier, 2009. - Vol. 77. - pp. 139--143.
- Reinhard J, Srinivasan M V, Guez D, Zhang S W** Floral scents induce recall of navigational and visual memories in honeybees Journal of experimental biology. The Company of Biologists Ltd, 2004. - Vol. 207. - pp. 4371--4381.
- Ribbands C R** Communication between honeybees: The response of crop-attached bees to the scent of their crop Proceedings of the Royal Entomological Society of London. Series A, General Entomology. - 1954. - Vol. 29. - pp. 141--144.
- Riley J R, Greggers U, Smith A D, Reynolds D R, Menzel R** The flight paths of honeybees recruited by the waggle dance Nature. - 2005.
- Riley J R and Smith A D** Design considerations for an harmonic radar to investigate the flight of insects at low altitude Computers and Electronics in Agriculture. Elsevier, 2002. - Vol. 35. - pp. 151--169.
- Risse H** Tracking von Honigbienen mit dem Algorithmus von Viola und Jones. Freie Universität Berlin, 2007.
- Rohrseitz K and Tautz J** Honey bee dance communication: waggle run direction coded in antennal contacts? Journal of Comparative Physiology A: Neuroethology, Sensory, Neural, and Behavioral Physiology. - may 1999. - Vol. 184. - pp. 463--470.
- Rundus A S, Owings D H, Joshi S S, Chinn E, Giannini N** Ground squirrels use an infrared signal to deter rattlesnake predation Proceedings of the National Academy of Sciences. National Acad Sciences, 2007. - Vol. 104. - p. 14372.
- Sandeman D, Tautz J and Lindauer M** Transmission of vibration across honeycombs and its detection by bee leg receptors J Exp Biol. - 1996. - Vol. 199. - pp. 2585-2594.
- Schmidt N** Tracking von Honigbienen mittels Active Appearance Models. Freie Universität Berlin, 2008.
- Schneider S S and Lewis L A** The vibration signal, modulatory communication and the organization of labor in honey bees, Apis mellifera Apidologie. EDP SCIENCES, 2004. - Vol. 35. - pp. 117--132.
- Schwaier T** BeeTube: A Management System for Digital Videos and the Visualization of Honeybee Trajectories. Freie Universität Berlin, 2010.

- Seeley T D and Visscher P K** Group decision making in nest-site selection by honey bees. *Apidologie*. - 2004. - Vol. 35. - pp. 101-116.
- Seeley T D** Social foraging in honey bees: how nectar foragers assess their colonies nutritional status *Behavioral Ecology and Sociobiology*. Springer, 1989. - Vol. 24. - pp. 181--199.
- Seeley T D** The tremble dance of the honey bee: message and meanings *Behavioral Ecology and Sociobiology*. Springer, 1992. - Vol. 31. - pp. 375--383.
- Seeley T D** *The Wisdom of the Hive: The Social Physiology of Honey Bee Colonies* [Book]. Harvard University Press, London, 1995.
- Seeley T D, Camazine S and Sneyd J** Collective decision-making in honey bees: how colonies choose among nectar sources *Behavioral Ecology and Sociobiology*. Springer, 1991. - Vol. 28. - pp. 277--290.
- Seeley T D, Mikheyev A S and Pagano G J** Dancing bees tune both duration and rate of waggle-run production in relation to nectar-source profitability *Journal of Comparative Physiology A: Neuroethology, Sensory, Neural, and Behavioral Physiology*. Springer, 2000. - Vol. 186. - pp. 813--819.
- Seeley T D, Mikheyev A S and Pagano G J** Dancing Bees tune both duration and rate of waggle-run production in relation to nectar-source profitability *J Comp Physiol A*. - 2000.
- Seeley T D, Weidenmüller A and Kühnholz S** The shaking signal of the honey bee informs workers to prepare for greater activity *Ethology*. Wiley Online Library, 1998. - Vol. 104. - pp. 10--26.
- Seeley T D [et al.]** Stop Signals Provide Cross Inhibition in Collective Decision-Making by Honeybee Swarms *Science*. - 2012. - Vol. 335. - pp. 108-111.
- Seeley T D and Visscher P K** Assessing the benefits of cooperation in honeybee foraging: search costs, forage quality, and competitive ability *Behavioral Ecology and Sociobiology*. - apr 1988. - Vol. 22. - pp. 229--237.
- Shearer D A and Boch R** 2-Heptanone in the Mandibular Gland Secretion of the Honey-bee *Nature*. - 05 01, 1965. - Vol. 206. - pp. 530--530.
- Sherman G and Visscher P K** Honeybee colonies achieve fitness through dancing *Nature*. - 2002. - Vol. 419. - pp. 920-922.
- Shi J and Tomasi C** Good features to track. - 1994. - pp. 593--600.
- Spangler H G** Do honey bees encode distance information into the wing vibrations of the waggle dance? *Journal of insect behavior*. Springer, 1991. - Vol. 4. - pp. 15--20.
- Srinivasan M, Zhang S, Lehrer M, Collett T** Honeybee navigation en route to the goal: visual flight control and odometry *J Exp Biol*. - 1996. - Vol. 199. - pp. 237-244.
- Srinivasan M V and Lehrer M** Spatial acuity of honeybee vision and its spectral properties *Journal of Comparative Physiology A: Neuroethology, Sensory, Neural, and Behavioral Physiology*. - mar 1988. - Vol. 162. - pp. 159--172.
- Stabentheiner A and Haggmüller K** Sweet food means Hot Dancing in honeybees *Naturwissenschaften*. - oct 1991. - Vol. 78. - pp. 471--473.

- Stabentheiner A, Kovac H and Haggmüller K** Thermal behavior of round and wagtail dancing honeybees *Journal of Comparative Physiology B: Biochemical, Systemic, and Environmental Physiology*. Springer, 1995. - Vol. 165. - pp. 433--444.
- Stabentheiner A, Kovac H and Schmaranzer S** Honeybee nestmate recognition: the thermal behaviour of guards and their examinees *J Exp Biol*. - 2002. - Vol. 205. - pp. 2637-2642.
- Steche W** Gelenkter Bienenflug durch Attrappentänze. *Naturwissenschaften*. Springer, 1957. - Vol. 44. - pp. 598-598.
- Storm J, Michelsen A and Rohrseitz K** Dancing honeybees generate jet air flows.. - 2002.
- Sumpter DJ, Krause J, James R, Couzin ID, Ward AJ** Consensus decision making by fish *Current Biology*. Elsevier, 2008. - Vol. 18. - pp. 1773--1777.
- Takanishi A, Aoki I, Ito M, Ohkawa Y, Yamaguchi J** Interaction between creature and robot: development of an experiment system for rat and rat robot interaction. - 1998. - Vol. 3. - pp. 1975--1980.
- Tanner S and Visscher K P** Do honey bees tune error in their dances in nectar-foraging and house-hunting? *Behavioral Ecology and Sociobiology*. - feb 2006. - Vol. 59. - pp. 571--576.
- Tanner S and Visscher K P** Does the body orientation of waggle dance followers affect the accuracy of recruitment? *Apidologie*. - jan 2009. - Vol. 40. - pp. 55-62.
- Tanner D and Visscher P K** Do honey bees average directions in the waggle dance to determine a flight direction? *Behavioral Ecology and Sociobiology*. - oct 2008. - Vol. 62. - pp. 1891--1898.
- Tanner D and Visscher P** Does Imprecision in The Waggle Dance Fit Patterns Predicted by The Tuned-Error Hypothesis? *Journal of Insect Behavior*. - pp. --.
- Tarpy D R, Gilley D C and Seeley T D** Levels of selection in a social insect: a review of conflict and cooperation during honey bee (*Apis mellifera*) queen replacement *Behavioral Ecology and Sociobiology*. - apr 2004. - Vol. 55. - pp. 513--523.
- Tautz J** Honeybee waggle dance: recruitment success depends on the dance floor *Journal of Experimental Biology*. - 1996. - Vol. 199. - pp. 1375-1381.
- Tautz J, Casas J and Sandeman D** Phase reversal of vibratory signals in honeycomb may assist dancing honeybees to attract their audience *J Exp Biol*. - 2001. - Vol. 204. - pp. 3737-3746.
- Taylor R C, Klein B, Stein J, Ryan M J** Faux frogs: multimodal signalling and the value of robotics in animal behaviour *Animal Behaviour*. London, Bailliere, Tindall and Cassell [etc.], 2008. - Vol. 76. - pp. 1089--1098.
- Thom C, Gilley D C and Tautz J** Worker piping in honey bees (*Apis mellifera*): the behavior of piping nectar foragers *Behavioral Ecology and Sociobiology*. Springer, 2003. - Vol. 53. - pp. 199--205.
- Thom C, Gilley D C, Hooper J, Esch H E** The Scent of the Waggle Dance *PLoS Biology*. - sep 2007. - Vol. 5. - p. e228.
- Thom C, Gilley D C and Tautz J** Worker piping in honey bees (*Apis mellifera*): the behavior of piping nectar foragers *Behavioral Ecology and Sociobiology*. - mar 2003. - Vol. 53. - pp. 199--205.

- Towne W F and Kirchner W H** Hearing in honey bees: detection of air-particle oscillations *Science*. American Association for the Advancement of Science, 1989. - Vol. 244. - p. 686. - 0036-8075.
- Towne W F and Gould J L** The spatial precision of the honey bees dance communication *Journal of Insect Behavior*. - apr 1988. - Vol. 1. - pp. 129--155.
- Tsujiuchi S, Sivan-Loukianova E, Eberl D F, Kitagawa Y, Kadowaki T** Dynamic Range Compression in the Honey Bee Auditory System toward Waggle Dance Sounds *PLoS ONE*. Public Library of Science, Feb 2007. - Vol. 2. - p. e234.
- Tuytelaars T and Mikolajczyk K** Local invariant feature detectors: a survey *Foundations and Trends in Computer Graphics and Vision*. Now Publishers Inc., 2008. - Vol. 3. - pp. 177--280.
- Veeraraghavan A and Chellappa R** Tracking Bees in a Hive. - 2008.
- Viola P and Jones M** Rapid object detection using a boosted cascade of simple features. - 2001. - Vol. 1. - pp. 1--511.
- von Frisch K** The language of bees. John Murray, 1937.
- Warnke U** Effects of electric charges on honeybees *Bee World*. - 1976. - Vol. 57. - pp. 50--56.
- Warnke U** Physikalisch-physiologische Grundlagen zur luftelektrisch bedingten Wetterföhligkeit der Honigbiene (*Apis Mellifica*) - 1973.
- Weidenmueller A and Seeley T D** Imprecision in waggle dances of the honeybee (*Apis mellifera*) for nearby food sources: error or adaptation? *Behavioral Ecology and Sociobiology*. - aug 1999. - Vol. 46. - pp. 190--199.
- Wells P H and Wenner A M** The influence of food scent on behavior of foraging honey bees *Physiological Zoology*. JSTOR, 1971. - Vol. 44. - pp. 191--209.
- Wenner A M and Johnson D L** Honeybees: do they use direction and distance information provided by their dancers? *Science*. - 1967. - Vol. 158. - pp. 1076-1077.
- Wenner A M and Johnson D L** Honeybees: do they use direction and distance information provided by their dancers? *Science*. - 1967. - Vol. 158. - pp. 1076-1077.
- Wenner A M** Sound production during the waggle dance of the honey bee *Animal Behaviour*. Elsevier, 1962. - Vol. 10. - pp. 79--95.
- Wenner A M** The elusive honey bee dance language hypothesis *J Insect Behav*. - 2002.
- Wenner A M, Wells P H and Johnson D L** Honey bee recruitment to food sources: olfaction or language? *Science*. - 1969. - Vol. 164. - pp. 84-86.
- Wenner A M, Wells P H and Johnson D L** Honey bee recruitment to food sources: olfaction or language? *Science*. - 1969. - Vol. 164. - pp. 84-86.