

3. Experimental Methods and Instrumentation.

3.1 UHV Setup

An ultrahigh vacuum chamber pumped by a turbo molecular pump with a base pressure in the low 10^{-10} mbar range was used (figure 3.1). This chamber contains a fully rotatable manipulator with facilities for sample heating by electron impact, sputter gun, and a gas inlet system by means of bakeable leak valves. It is equipped with a cylindrical mirror analyzer from Omicron for Auger electron spectroscopy (AES) and a Balzers quadrupole mass spectrometer (QMS200) which is horizontally mounted. Thermal programmed analyses were performed by placing the sample ~ 1 mm away from the aperture of a stainless steel tube connected to the ionization region of the QMS. This stainless steel tube shields the QMS from the surrounding and reduces the number of molecules desorbed from the sample holder and other UHV parts that reach the MS ionization chamber. This way it ensures that the majority of the detected species originate from the sample itself.

Photoelectron spectroscopy measurements were carried out in a second UHV chamber. X-ray photoelectron spectroscopy (XPS) was carried out using Mg K α radiation ($h\nu = 1253.6$ eV). A Concentric Hemispherical Analyser (CHA) was used for both techniques.

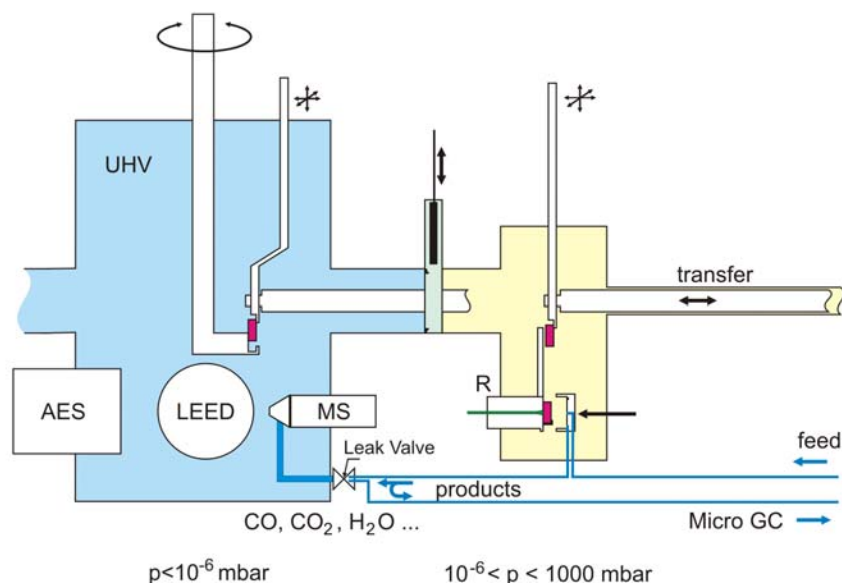

Figure 3.1. Schematic diagram of the microflow reactor with the connected ultrahigh vacuum chamber

3.2 Micro-flow reactor

All conversion experiments were performed in a microflow reactor¹ which is connected to the UHV chamber. This reactor enables the observation of reactions on single crystal catalysts in a flow setup simulating the real reaction conditions. In addition, it enables the application of higher pressures up to 1 bar. Sample heating is achieved by the use of two diode laser stacks with a total power reaching 100 W. This setup which enables the use of small reactant volumes has the advantage that the sample is the hottest spot in the whole area inside the reaction zone. This fact is essential in excluding the contribution of any of the reactor components in the catalytic process.

The reactor is constructed on a 70 mm od flange. This flange carries the feedthroughs for the thermocouple and the fiber rods used for heating sample by laser irradiation. The reaction cap is supplied with two flexible capillaries. One is used for reactant admission (inlet) while the other used as product gas outlet.

While the reactor is opened (figure 2a), the sample can be inserted into its position using a wobble stick, and after retraction of the wobble stick, the reactor cap can be closed using a linear motion drive (fig 2b). This arrangement represents a stagnation point reactor with a total volume of about 4 ml.

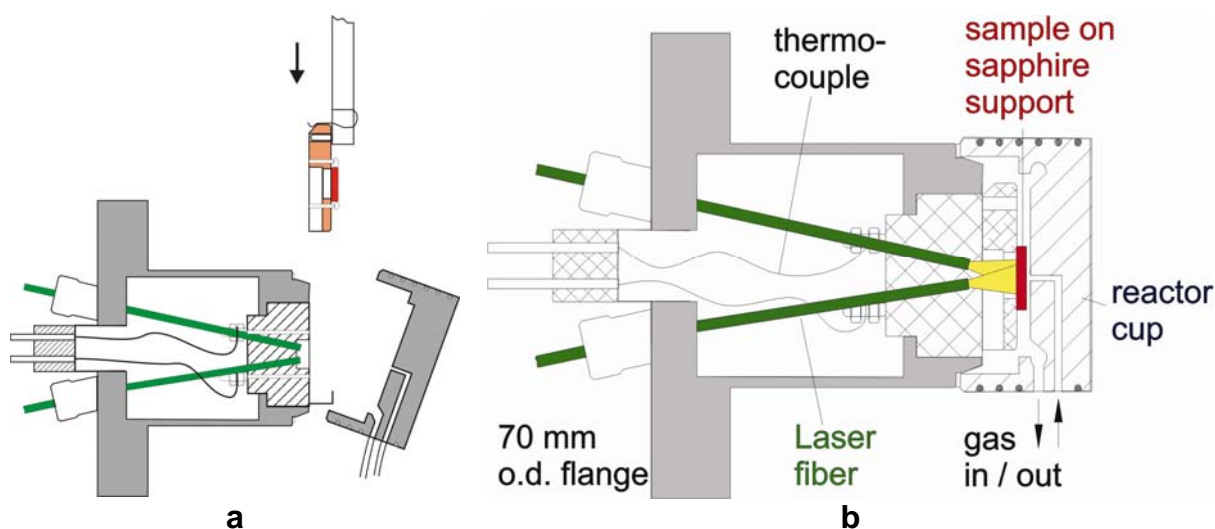

Figure 3.2. Schematic diagram of the microflow reactor, (a) opened during sample insertion, (b) after closing

3.3 Gas mixing system

Reaction gas mixture is composed of ethylbenzene and oxygen diluted in helium. The concentration of both ethylbenzene and oxygen was in the range of 1-2 %. To attain the needed concentrations of the reactants, a gas mixing system was used as shown in figure 3.3.

This system enables controlling the flow rates of three different gas streams by the use of mass flow controllers (MF1, MF2, MF3 in figure 3.3) from Bronkhorst. The first stream is ethylbenzene in helium, the second is oxygen in helium and the third is pure helium. According to the needed reactant concentrations, the flow rates of the three gas streams were adjusted and the three streams were then unified in one stream and redirected to the reactor. The performance of this mixing system was tested during the calibration procedure of the micro GC instrument. It was found to be enough accurate and reliable.

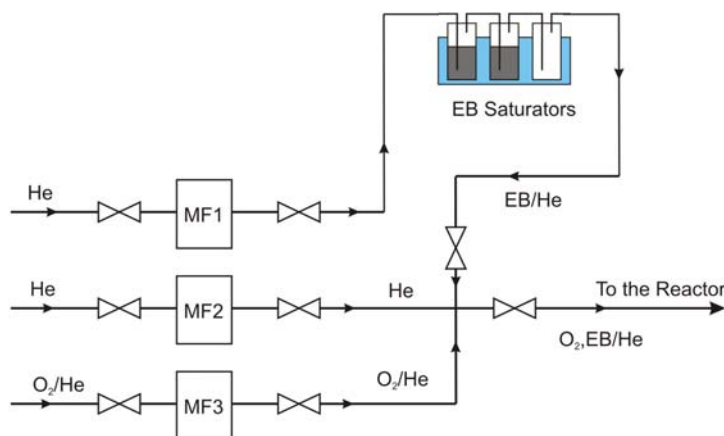

Figure 3.3 Schematic diagram of the reaction gas mixing system

3.4 Saturators

Ethylbenzene was supplied to the system by passing a helium stream through two saturators filled with ethyl benzene followed by a third empty saturator to enable the removal of any liquid droplets. In order to increase the gas/liquid contact time allowing better saturation of the gas, the ethylbenzene saturators were filled with glass balls. Ethylbenzene concentration in the stream was calculated using its vapor pressure value at the ambient temperature.

3.5 Micro GC

Quantification of conversion experiments products was conducted using a 4-channel micro GC system (CP 4900) from Varian. Each channel is a complete miniaturized GC system equipped with a heated silicon micro-machined variable volume injector, a narrow-bore column and 200 nl volume thermal conductivity detector. More information about each of these channels is given in the table below. Controlling and data acquisition was achieved using a CP Maître-Elite-GC software.

Channel	Column	Carrier gas	Detected species
1	10m Molecular Sieve 5A	Argon	He, O ₂ , N ₂
2	20m Molecular Sieve 5A	Helium	CO, O ₂ , N ₂
3	10m Pora plot Q	Helium	CO ₂
4	Wax column	Helium	Aromatics

3.6 Sample mounting

The samples were mounted on sample holders made of sapphire (Figure 3.4). This material is a good choice for our experiments and for ultra high vacuum systems in general because of its chemical inertness, mechanical stability, and unique thermal conductivity behaviour. It has a high thermal conductivity below room temperature which helps in cooling the sample where needed. On the other hand and at elevated temperatures it has a low thermal conductivity; this reduces the heat loss by conductance from the sample during annealing. Sapphire is an electrical insulator, too. This is essential in applying the used approach for temperature heating (by electron impact) and measurement (by k-type thermocouple) and applying bias voltage in photoemission measurements.

The sample holder has a hole below the sample which permits heating the sample from behind either by electron bombardment or laser irradiation. 4 holes around the sample are used to mount 4 screws. Two of them are used for sample fastening and electrical connection and the other two are used for mounting the thermocouple. When placing the sample holder in its place in the manipulator these screws provide contact by touching spring bolts from behind. A K-type thermocouple was used to measure the sample temperature by passing the thermocouple tip through a narrow hole made along the graphite sample.

3.7 Sample cleaning and preparation prior to experiments.

After mounting, the sample was washed with bi-distilled water and then with ethanol before it was air dried. In the ultrahigh vacuum chamber, the sample was heated up to 1000 °C using electron bombardment filament which is placed in a ceramic tube just behind the sample.

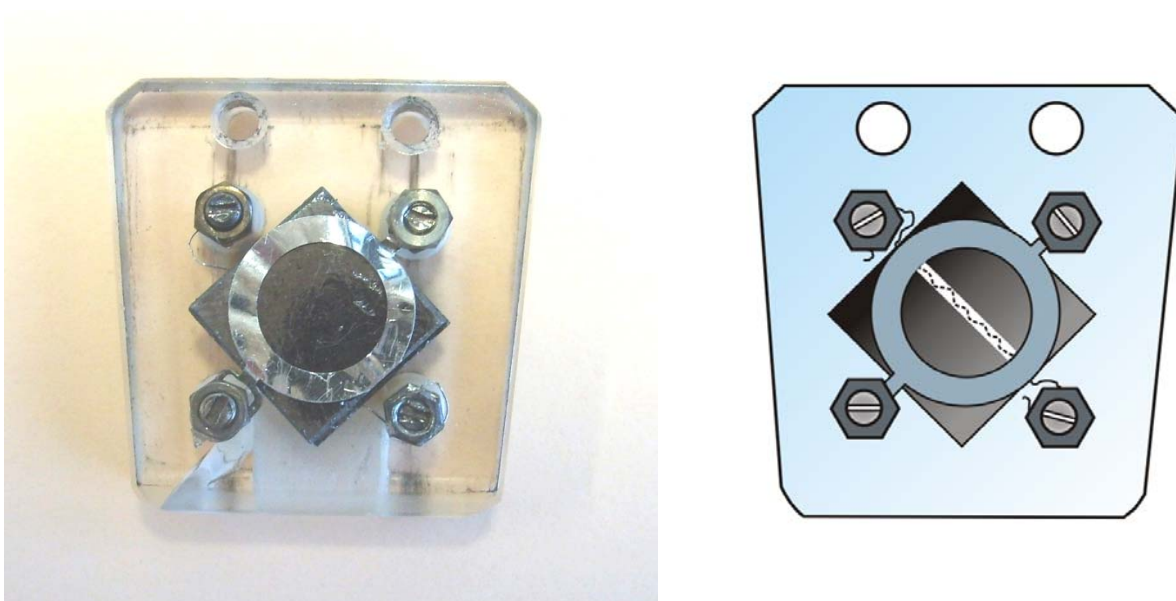

Figure 3.4. HOPG Sample mounted on the sapphire sample holder

3.8 Carbon Nanotubes Samples.

the used CNT samples were obtained from Applied Science Inc.. This material is prepared by chemical vapor deposition technique using iron catalyst. The sample (Id. PS-LD) is iron-free with a BET Area of $5.48 \times 10^{+01}$ m²/g and an average pore width of 5.6 nm. The sample was used without any pretreatment.

- **Sample preparation procedure**

- 1- Small amount of CNT (~0.004 g) was weighed in a small beaker
- 2- 2 ml of CHCl₃ was added to perform a suspension which was sonicated for 3 minutes. This suspension was then used to prepare the samples by taking definite small volumes (0.02 ml)with a micropipette and dropping it on the

surface of the substrate (HOPG or Steel). Sonication was repeated before taking every volume.

3- After leaving samples to dry in air for an hour, they were transferred to UHV, after which it was heated in vacuum for 5 minutes at 480 °C.

- **Calculation of sample amount in CNT**

Example of calculating the amount of CNT deposited on an HOPG sample

Concentration of CNT in the prepared suspension (4.4 mg CNT in 2 ml CHCl_3) = 2.2 mg/ml

Weight of deposited CNT = deposited volume x concentration
= 2 x 0.02 ml x 2.2×10^{-3} g/ml = 8.8×10^{-5} g = 0.088 mg

Note:

It should be mentioned here that the above calculation was done assuming complete homogeneity of the prepared suspension. Nevertheless, this is not the case. And a significant error in the calculated CNT amount and BET area can not be excluded. Weighing the substrate before and after CNT deposition could not be used to determine the amount of CNT because of the large difference between the weight of the sample and the deposited weight of CNT.

3.9 Reaction procedure.

After transferring the sample to the reactor, the reactor is closed and the reactor cup is then heated up to 200 °C in vacuum for about 15 minutes to degas. The high pressure chamber is then vented with argon up to 1 atm. Pure helium gas flow is admitted to the reactor and sample is then heated to the reaction temperature. Upon reaching the reaction temperature, the pure helium gas flow is replaced with the preheated reactants/helium admixture.

The experiment is finished by replacing the reaction gas flow with pure helium and switching off laser heating. The sample is left to reach a temperature below 200 °C

before the helium gas stream is stopped, the reactor and the high pressure chamber are evacuated. Finally the sample is transferred back to the characterization chamber for post-reaction characterization.

3.10 Temperature Measurement

Temperature measurement was done using K-type (Chromel/Alumel) thermocouple, which is applicable in the range of $-200\text{ }^{\circ}\text{C}$ to $1200\text{ }^{\circ}\text{C}$. The thermocouple tip was passed through a narrow hole made along the HOPG sample parallel to the surface. As mentioned before, the heating was achieved by electron bombardment filament behind the sample. However, the thermal conductivity behaviour of HOPG is an issue in this case, because the heat source is behind the sample, the region of interest is the front surface of the sample and the measuring point is in-between (figure 3.5).

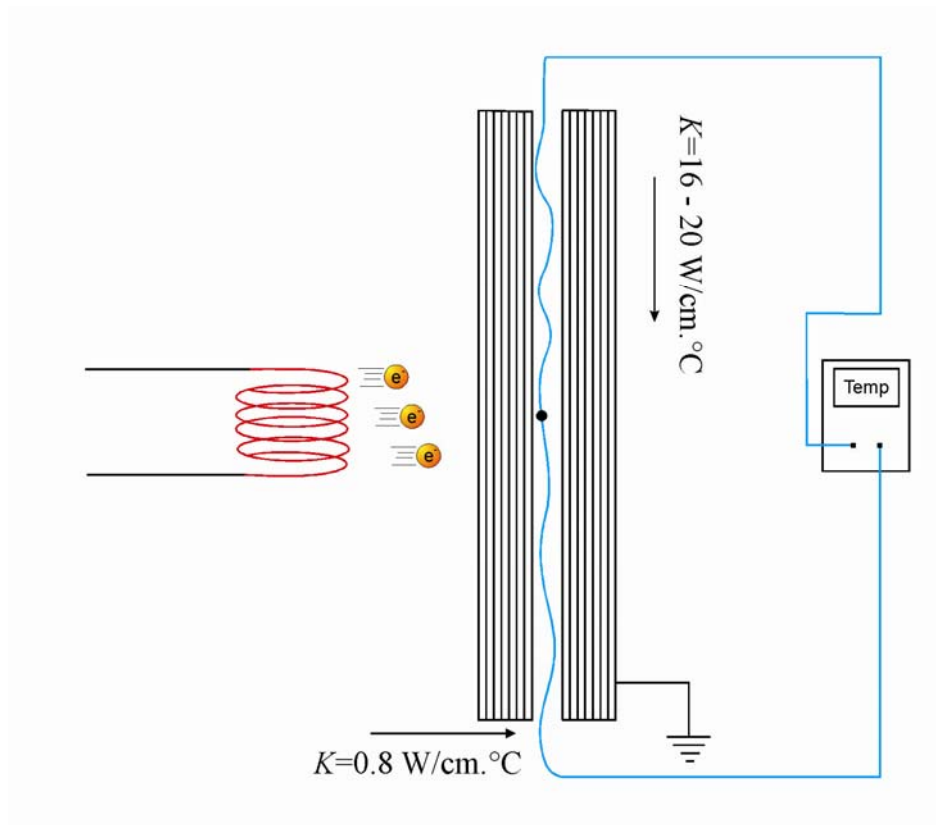

Figure 3.5 Temperature measurement of HOPG sample

Although HOPG is a very good thermal conductor in the direction parallel to basal plane of the crystal with a thermal conductivity (k) of $16 - 20\text{ Watt/cm.}^{\circ}\text{C}$, it is an insulator in the direction perpendicular to the basal plane (thermal conductivity (k): $0.8\text{ Watt/cm.}^{\circ}\text{C}$).

In the light of the poor thermal conductivity of HOPG in the direction perpendicular to the basal plane, it is expected that we have a temperature gradient in that direction. In order to determine the difference between the measured temperature (bulk temperature) and that of the surface, the thermocouple measurements were compared to those obtained simultaneously using a pyrometer (emmissivity, $\epsilon=0.8$). In the range of 500 – 800 °C which is the range of interest, the absolute difference was found to be in the range of +/- 25 °C.

3.11 Highly Oriented Pyrolytic Graphite (HOPG) (Sample Preparation)

The used HOPG samples were of grade ZYB (angular spread angle of 0.8° % +/- 0.2°) from MaTeck with the following dimensions 9mm x 9mm x 2mm. New samples were washed with water and ethanol. After introduction to UHV, they were annealed for 10 minutes at 1000 °C in UHV conditions to remove the hydrocarbon residues from the production process.

Before every experiment, HOPG samples were cleaved to produce fresh surface. Cleavage was done by pressing a piece of stick tape on the surface and then gently peeling it off the surface. This was repeated (if necessary) until an HOPG surface which appears flat for the naked eye was got.

3.12 Principles of analytical methods

- **Auger Electron Spectroscopy (AES)**

Auger electron effect: when an atom is ionized by the production of core hole, the ion eventually loses some of its potential energy by filling this core hole with an electron from a higher level together with the emission of energy which appears either as a photon or as a kinetic energy emitting another electron with characteristic energy. This electron is called Auger electron and it is characteristic for different elements especially the light ones.

Auger electron spectroscopy is an electron spectroscopy in which a sample is excited with a beam of primary electrons with kinetic energy between 1 and 10 keV. As a

result, Auger electrons are emitted. By measuring the energy of emitted electrons, Auger electron spectroscopy can probe the composition and chemistry of a surface.

- **Scanning Electron Microscopy (SEM)**

It is an imaging technique in which a narrow electron beam is scanned over the surface and the yield of either secondary or backscattered electrons is detected as a function of the position of the primary beam. The used system is an S-4800 from Hitachi equipped with a cold FEG (Field Emission Gun).

- **X-ray Photoelectron Spectroscopy (XPS)**

X-ray photoelectron spectroscopy is a surface chemical spectroscopic technique that is used to analyze the chemistry of the surface of a material². It is based on the photoelectric effect in which an atom adsorbs a photon of energy ($h\nu$). Next, a core electron with binding energy E_b is ejected with kinetic energy (E_k) according to the equation below.

$$E_k = h\nu - E_b - \varphi, \quad \varphi : \text{work function of the surface}$$

- **Thermal programmed techniques.**

Temperature programmed desorption is a technique in which the desorption rate from the surface is monitored upon linearly increasing the sample temperature. The technique gives quantitative information about the adsorbates on the surface, in addition to information about the partial coverage and (adsorbate-surface) bonding strength of different adsorbates. The used heating rate was 1 °C/s unless stated otherwise.

3.13 Materials:

The Ethylbenzene used was a reagentPlus grade 99% ordered from Sigma-Aldrich, styrene used for gas chromatography calibration was a 99% GC grade ordered from Sigma-Aldrich.

All gases used were of 99.998 % or better purity

- (1) Kuhrs, C.; M.Swoboda; Weiss, W. *Topics in Catalysis* **2001**, *15*.
- (2) Briggs, D.; Seah, M. P. In *Practical Surface Analysis* Wiley: 1990; Vol. 1