

# French subject islands

Empirical and formal approaches

Elodie Winckel

Empirically Oriented Theoretical  
Morphology and Syntax 14



## Empirically Oriented Theoretical Morphology and Syntax

Chief Editor: Stefan Müller

Consulting Editors: Berthold Crysmann, Ana R. Luís

In this series:

1. Lichte, Timm. Syntax und Valenz: Zur Modellierung kohärenter und elliptischer Strukturen mit Baumadjunktionsgrammatiken.
2. Bilbîie, Gabriela. Grammaire des constructions elliptiques: Une étude comparative des phrases sans verbe en roumain et en français.
3. Bower, Claire, Laurence Horn & Raffaella Zanuttini (eds.). On looking into words (and beyond): Structures, Relations, Analyses.
4. Bonami, Olivier, Gilles Boyé, Georgette Dal, Hélène Giraudo & Fiammetta Namer. The lexeme in descriptive and theoretical morphology.
5. Guzmán Naranjo, Matías. Analogical classification in formal grammar.
6. Flick, Johanna. Die Entwicklung des Definitartikels im Althochdeutschen: Eine kognitiv-linguistische Korpusuntersuchung.
7. Crysmann, Berthold & Manfred Sailer (eds.). One-to-many relations in morphology, syntax, and semantics.
8. Zinova, Yulia. Russian verbal prefixation: A frame semantic analysis.
9. Müller, Stefan, Anne Abeillé, Robert D. Borsley & Jean-Pierre Koenig. Head-Driven Phrase Structure Grammar: The handbook.
10. Diewald, Gabriele & Katja Politt (eds.). Paradigms regained: Theoretical and empirical arguments for the reassessment of the notion of paradigm.
11. Freywald, Ulrike, Horst J. Simon & Stefan Müller (eds.). Headedness and/or grammatical anarchy?
12. Kawaletz, Lea. The semantics of English *-ment* nominalizations.
13. Dalrymple, Mary (ed.). Handbook of Lexical Functional Grammar.
14. Winckel, Elodie. French subject islands: Empirical and formal approaches.

ISSN: 2366-3529



# French subject islands

Empirical and formal approaches

Elodie Winckel

Elodie Winckel. 2024. *French subject islands: Empirical and formal approaches* (Empirically Oriented Theoretical Morphology and Syntax 14). Berlin: Language Science Press.

This title can be downloaded at:

<http://langsci-press.org/catalog/book/362>

© 2024, Elodie Winckel

Published under the Creative Commons Attribution 4.0 Licence (CC BY 4.0):

<http://creativecommons.org/licenses/by/4.0/>

This thesis is a revised version of my dissertation, which was accepted in 2020 by the Faculty of Language, Literature and Humanities of the Humboldt-Universität zu Berlin and by the doctoral school 622 “Sciences du langage” of the Université de Paris in the specialty “language science” for the degree of doctor philosophiae (Dr. phil.), and defended in 2021.

ISBN: 978-3-96110-477-2 (Digital)

978-3-98554-106-5 (Hardcover)

ISSN: 2366-3529

DOI: 10.5281/zenodo.11635096

Source code available from [www.github.com/langsci/362](http://www.github.com/langsci/362)

Errata: [paperhive.org/documents/remote?type=langsci&id=362](http://paperhive.org/documents/remote?type=langsci&id=362)

Cover and concept of design: Ulrike Harbort

Proofreading: Amir Ghorbanpour, Annie Zaenen, Brett Reynolds, Elliott Pearl, Hannah Schlepner, Janina Rado, Mary Ann Walter, Wilson Lui

Fonts: Libertinus, Arimo, DejaVu Sans Mono

Typesetting software: Xe<sub>La</sub>T<sub>E</sub>X

Language Science Press

xHain

Grünberger Str. 16

10243 Berlin, Germany

<http://langsci-press.org>

Storage and cataloguing done by FU Berlin

Freie Universität  Berlin

# Contents

Acknowledgments	xiii
Collaborative work	xvii
<b>I Subextraction from subjects: State of the art</b>	<b>1</b>
<b>1 Introduction</b>	<b>3</b>
1.1 Some definitions . . . . .	3
1.2 Extractions in French . . . . .	6
1.3 Some remarks on subject extraction . . . . .	9
1.3.1 Extraction of the subject in relative clauses . . . . .	10
1.3.2 Extraction of the subject in interrogatives . . . . .	11
1.4 A definition of “islands” . . . . .	12
1.4.1 The notion of “islands” over time . . . . .	12
1.4.2 Definition adopted in this work . . . . .	14
1.4.3 Identifying islands through empirical work . . . . .	14
1.5 The structure of this book . . . . .	15
<b>2 Syntactic approaches to the “Subject Condition”</b>	<b>19</b>
2.1 The Sentential Subject Constraint of Ross (1967) . . . . .	20
2.2 The Subject Condition: subextraction from subject NPs . . . . .	23
2.2.1 The start: Chomsky (1973) . . . . .	27
2.2.2 The subject is a non-complement: The CED and its successors . . . . .	30
2.2.3 The subject is a specifier: The Connectedness Condition and other “specifier”-based analyses . . . . .	35
2.2.4 The subject is moved: Freezing analyses . . . . .	41
2.3 The subject island constraint cross-linguistically . . . . .	44
2.3.1 The discussion around French . . . . .	44
2.3.2 Other cross-linguistic counterexamples . . . . .	53
2.4 Criticisms of the syntactic approach . . . . .	56
2.4.1 Non-syntactic factors increasing the acceptability . . . . .	56

## Contents

2.4.2	“Parasitic” gaps . . . . .	57
2.4.3	Gradient grammaticality . . . . .	59
2.5	The subject island constraint in HPSG . . . . .	62
<b>3</b>	<b>Processing approaches</b>	<b>65</b>
3.1	General mechanisms of processing associated with extraction . . . . .	65
3.1.1	Processing cost for the filler . . . . .	66
3.1.2	Processing cost for the gap . . . . .	66
3.2	Dependency-length minimization . . . . .	67
3.2.1	Dependency Locality Theory (DLT) . . . . .	69
3.2.2	Dependency Grammar . . . . .	70
3.3	Processing accounts based on surprisal . . . . .	72
3.3.1	Processing difficulty of subjects . . . . .	72
3.3.2	Valency Completeness . . . . .	75
3.4	Definiteness, referentiality and specificity . . . . .	76
<b>4</b>	<b>Discourse-based approaches</b>	<b>79</b>
4.1	Information structure . . . . .	80
4.1.1	Topic and comment . . . . .	81
4.1.2	Focus . . . . .	82
4.1.3	Background (and presuppositional content) . . . . .	86
4.2	General principles: from Erteschik-Shir’s dominance constraint on extraction to Goldberg’s “Backgrounded Constituents are Islands” . . . . .	87
4.2.1	The Focus approach . . . . .	87
4.2.2	The Topic approach . . . . .	88
4.2.3	The salience approach (reconciling the Focus and Topic approaches) . . . . .	89
4.3	The subject island constraint from a functional perspective . . . . .	90
4.4	The BCI revisited: the Focus-Background Conflict constraint . . . . .	91
<b>5</b>	<b>Concluding remarks on the state of the art</b>	<b>95</b>
<b>II</b>	<b>Empirical studies on subextraction of subjects in French</b>	<b>97</b>
<b>6</b>	<b>Preliminary remarks on the empirical data</b>	<b>99</b>
<b>7</b>	<b>Previous experimental work on subextraction from subjects</b>	<b>105</b>
7.1	Interrogatives . . . . .	105

7.2	Other constructions . . . . .	115
7.3	Sentential subjects . . . . .	115
<b>8</b>	<b>Empirical data on <i>dont</i> relative clauses</b>	<b>119</b>
8.1	Corpus studies on <i>dont</i> . . . . .	120
8.1.1	Motivation . . . . .	120
8.1.2	A previous exploration of <i>dont</i> in the FTB (Candito & Seddah) . . . . .	123
8.1.3	Procedure . . . . .	124
8.1.4	Results and analysis . . . . .	127
8.1.5	General conclusion on the corpus studies on <i>dont</i> . . . . .	140
8.2	Experiment 1: Acceptability judgment study on <i>dont</i> relative clauses with different linear distances . . . . .	141
8.2.1	Design and materials . . . . .	142
8.2.2	Predictions . . . . .	144
8.2.3	Procedure . . . . .	144
8.2.4	Participants . . . . .	145
8.2.5	Results and analysis . . . . .	146
8.2.6	Discussion . . . . .	155
8.3	Experiment 2: Speeded acceptability judgment study on <i>dont</i> relative clauses with different linear distances . . . . .	157
8.3.1	Design and materials . . . . .	157
8.3.2	Experimental method . . . . .	159
8.3.3	Predictions . . . . .	159
8.3.4	Procedure . . . . .	160
8.3.5	Participants . . . . .	160
8.3.6	Results and analysis . . . . .	160
8.3.7	Discussion . . . . .	167
8.4	Experiment 3: Eye tracking study on <i>dont</i> relative clauses with different linear distances . . . . .	168
8.4.1	Design and materials . . . . .	168
8.4.2	Experimental method . . . . .	170
8.4.3	Predictions . . . . .	172
8.4.4	Procedure . . . . .	174
8.4.5	Participants . . . . .	174
8.4.6	Results and analysis . . . . .	175
8.4.7	Discussion . . . . .	180

## Contents

8.5	Experiment 4: Acceptability judgment study on <i>dont</i> relative clauses with long-distance dependencies . . . . .	181
8.5.1	Design and materials . . . . .	181
8.5.2	Predictions . . . . .	184
8.5.3	Procedure . . . . .	185
8.5.4	Participants . . . . .	185
8.5.5	Results and analysis . . . . .	185
8.5.6	Discussion . . . . .	192
<b>9</b>	<b>Empirical data on <i>de qui</i> relative clauses</b>	<b>193</b>
9.1	Corpus studies on <i>de qui</i> . . . . .	194
9.1.1	Motivation . . . . .	194
9.1.2	Procedure . . . . .	195
9.1.3	Results and analysis for relative clauses . . . . .	196
9.1.4	Results for interrogatives . . . . .	205
9.1.5	Results for <i>c'est</i> -clefts . . . . .	209
9.1.6	General conclusion on the corpus studies on <i>de qui</i> . . .	210
9.2	Experiment 5: Acceptability judgment study on <i>de qui</i> relative clauses with an animate antecedent and animacy mismatch between subject and object . . . . .	211
9.2.1	Design and materials . . . . .	211
9.2.2	Predictions . . . . .	212
9.2.3	Procedure . . . . .	212
9.2.4	Participants . . . . .	214
9.2.5	Results and analysis . . . . .	214
9.2.6	Discussion . . . . .	221
9.3	Experiment 6: Acceptability judgment study on <i>dont</i> relative clauses with an animate antecedent and an animacy mismatch between subject and object . . . . .	221
9.3.1	Design and materials . . . . .	221
9.3.2	Predictions . . . . .	222
9.3.3	Procedure . . . . .	223
9.3.4	Participants . . . . .	223
9.3.5	Results and analysis . . . . .	223
9.3.6	Discussion . . . . .	228
9.4	Experiment 7: Acceptability judgment study on <i>de qui</i> relative clauses with animate subject and object . . . . .	229
9.4.1	Design and materials . . . . .	230
9.4.2	Predictions . . . . .	232

9.4.3	Procedure . . . . .	232
9.4.4	Participants . . . . .	232
9.4.5	Results and analysis . . . . .	233
9.4.6	Discussion . . . . .	240
9.5	Experiment 8: Acceptability judgment study on <i>dont</i> relative clauses with an animate antecedent and animate subject and object . . . . .	243
9.5.1	Design and materials . . . . .	243
9.5.2	Predictions . . . . .	244
9.5.3	Procedure . . . . .	245
9.5.4	Participants . . . . .	245
9.5.5	Results and analysis . . . . .	245
9.5.6	Discussion . . . . .	251
9.6	Experiment 9: Self-paced reading study on <i>de qui</i> relative clauses with an animate antecedent and animate subject and object . . . . .	252
9.6.1	Design and materials . . . . .	252
9.6.2	Experimental method . . . . .	254
9.6.3	Predictions . . . . .	254
9.6.4	Procedure . . . . .	256
9.6.5	Participants . . . . .	256
9.6.6	Results and analysis . . . . .	257
9.6.7	Discussion . . . . .	262
<b>10</b>	<b>Corpus studies on other relative clauses</b>	<b>265</b>
10.1	Corpus study on <i>duquel</i> . . . . .	265
10.1.1	Motivation . . . . .	265
10.1.2	Procedure . . . . .	265
10.1.3	Results and analysis . . . . .	267
10.1.4	Conclusion . . . . .	271
10.2	<i>Avec</i> + <i>wh-</i> in Frantext . . . . .	272
10.2.1	Motivation . . . . .	272
10.2.2	Procedure . . . . .	272
10.2.3	Results and analysis for relative clauses . . . . .	273
10.2.4	Results for interrogatives . . . . .	279
10.2.5	Results for <i>c'est</i> -clefts . . . . .	281
10.2.6	Conclusion . . . . .	281

<b>11 Empirical data on questions</b>	<b>283</b>
11.1 <i>De quel</i> in Frantext	284
11.1.1 Motivation	284
11.1.2 Procedure	284
11.1.3 Results and analysis	285
11.1.4 Conclusion	288
11.2 Attested extractions out of the subject in interrogatives	288
11.2.1 Examples with a pre-defined set of alternatives	288
11.2.2 Questions with a pre-defined answer (rhetorical question)	290
11.2.3 Conclusion on the extractions out of subjects found on the Internet	291
11.3 Experiment 10: Acceptability judgment study on <i>de quel</i> <i>wh</i> -questions with <i>wh</i> -extraction	291
11.3.1 Design and materials	292
11.3.2 Predictions	293
11.3.3 Procedure	294
11.3.4 Participants	294
11.3.5 Results and analysis	296
11.3.6 Discussion	302
11.4 Experiment 11: Acceptability Judgment study on <i>de quel</i> <i>wh</i> -questions with the <i>wh</i> -word in situ	303
11.4.1 Design and materials	304
11.4.2 Predictions	305
11.4.3 Procedure	306
11.4.4 Participants	306
11.4.5 Results and analysis	307
11.4.6 Discussion	313
11.4.7 The discursive status of in-situ questions	314
11.5 Experiment 12: Acceptability judgment study on <i>de qui</i> <i>wh</i> -questions with <i>wh</i> -extraction	315
11.5.1 Design and materials	315
11.5.2 Predictions	317
11.5.3 Procedure	317
11.5.4 Participants	317
11.5.5 Results and analysis	317
11.5.6 Discussion	325
11.6 Experiment 13: Acceptability judgment study on <i>de quel</i> <i>wh</i> -questions with long-distance dependencies	326
11.6.1 Design and materials	327



11.6.2	Predictions . . . . .	328
11.6.3	Procedure . . . . .	329
11.6.4	Participants . . . . .	329
11.6.5	Results and analysis . . . . .	329
11.6.6	Discussion . . . . .	336
<b>12</b>	<b>Experiment on <i>c'est</i>-clefts</b>	<b>337</b>
12.1	Information structure of <i>c'est</i> -clefts . . . . .	337
12.2	Experiment 14: Acceptability judgment study on <i>c'est</i> -clefts . . .	339
12.2.1	Design and materials . . . . .	339
12.2.2	Predictions . . . . .	341
12.2.3	Procedure . . . . .	343
12.2.4	Participants . . . . .	343
12.2.5	Results and analysis . . . . .	343
12.2.6	Discussion . . . . .	350
<b>13</b>	<b>Experiments on infinitival subjects</b>	<b>351</b>
13.1	Experiment 15: Acceptability judgment study on subextraction from infinitivals with <i>où</i> . . . . .	352
13.1.1	Design and materials . . . . .	352
13.1.2	Predictions . . . . .	353
13.1.3	Procedure . . . . .	355
13.1.4	Participants . . . . .	355
13.1.5	Results and analysis . . . . .	355
13.1.6	Discussion . . . . .	361
13.2	Experiment 16: Acceptability judgment study on subextraction from infinitivals with <i>que</i> . . . . .	361
13.2.1	Design and materials . . . . .	362
13.2.2	Predictions . . . . .	363
13.2.3	Procedure . . . . .	363
13.2.4	Participants . . . . .	363
13.2.5	Results and analysis . . . . .	364
13.2.6	Discussion . . . . .	369
<b>14</b>	<b>Conclusions on the empirical data</b>	<b>371</b>
14.1	Extraction out of the NP and extraction out of the subject . . . .	371
14.2	Cross-construction difference . . . . .	372
14.2.1	Relative clauses . . . . .	373
14.2.2	Focalizations (interrogatives and <i>c'est</i> -clefts) . . . . .	374

## Contents

14.2.3	Extraction out of a verbal subject . . . . .	376
14.3	Discourse clash . . . . .	377
14.4	Verb types . . . . .	377
14.4.1	Extraction out of the subject of transitive verbs . . . . .	377
14.4.2	A remark on psychological verbs . . . . .	378
14.5	A remark on hanging topics . . . . .	383
14.6	A cross-linguistic perspective . . . . .	385
<b>III</b>	<b>Formal analysis</b>	<b>389</b>
<b>15</b>	<b>General discussion</b>	<b>391</b>
15.1	Clarifying the FBC constraint . . . . .	391
15.2	The FBC in long-distance dependencies . . . . .	394
15.3	The puzzle of <i>it</i> -clefts . . . . .	396
15.3.1	The information structure of the <i>that</i> -clause . . . . .	396
15.3.2	A problem for the FBC constraint? . . . . .	398
15.3.3	Other extractions out of the <i>that</i> -clause . . . . .	399
15.3.4	Assumptions in this book . . . . .	400
<b>16</b>	<b>A French HPSG fragment</b>	<b>401</b>
16.1	General principles of an HPSG grammar . . . . .	402
16.1.1	Syntax . . . . .	404
16.1.2	Semantics . . . . .	412
16.1.3	Information structure . . . . .	415
16.2	Extraction in HPSG . . . . .	425
16.2.1	A traceless analysis . . . . .	426
16.2.2	<i>Wh</i> -questions . . . . .	430
16.2.3	Relative clauses . . . . .	436
16.2.4	<i>C'est</i> -clefts . . . . .	443
16.2.5	Long-distance dependencies . . . . .	449
<b>17</b>	<b>Extraction out of subject NPs</b>	<b>453</b>
17.1	Noun dependents in French . . . . .	453
17.2	The subject as Designated Topic . . . . .	457
17.3	Formalization of the Focus-Background Conflict constraint in HPSG . . . . .	458
17.3.1	Implementing the FBC constraint . . . . .	459
17.3.2	The FBC constraint in interrogatives . . . . .	461

17.3.3	The FBC constraint in <i>c'est</i> -clefts . . . . .	463
17.3.4	The FBC constraint in relatives . . . . .	466
<b>18</b>	<b>Extraction out of infinitival and sentential subjects</b>	<b>471</b>
18.1	Sentential subjects . . . . .	472
18.2	Infinitival subject . . . . .	474
<b>19</b>	<b>Conclusion</b>	<b>477</b>
<b>IV</b>	<b>Concluding remarks</b>	<b>479</b>
<b>20</b>	<b>Concluding remarks</b>	<b>481</b>
<b>V</b>	<b>Appendices</b>	<b>485</b>
	<b>Appendix A: Corpus annotation guidelines</b>	<b>487</b>
	<b>Appendix B: Semantic relations in relative clauses (corpus studies)</b>	<b>489</b>
B.1	<i>Dont</i> relatives in the French Treebank . . . . .	493
B.2	<i>Dont</i> relatives in Frantext 2000–2013 . . . . .	494
B.3	<i>Dont</i> relatives in Frantext 1900–1913 . . . . .	496
B.4	<i>De qui</i> relatives in Frantext 2000–2013 . . . . .	498
B.5	<i>De qui</i> relatives in Frantext 1900–1913 . . . . .	500
B.6	<i>Duquel</i> relatives in Frantext 2000–2013 . . . . .	501
B.7	Conclusion . . . . .	502
	<b>Appendix C: Number, definiteness and restrictiveness in relative clauses (corpus studies)</b>	<b>503</b>
	<b>Appendix D: Exclusion criteria for participants' data</b>	<b>509</b>
	<b>Appendix E: Experiment 3, detailed results and analysis</b>	<b>511</b>
E.1	Total reading times . . . . .	511
E.2	Regressions in region 3 (subject) . . . . .	513
E.3	First fixations and regression path durations in region 4 (verb) . . . . .	519
E.4	Regressions in region 5 (object) . . . . .	521
E.5	Regressions at the extraction site (subject/object) . . . . .	526
E.6	Regressions in region 2 (relative word) . . . . .	528

*Contents*

<b>References</b>	<b>533</b>
<b>Index</b>	<b>561</b>
Name index . . . . .	561

I dedicate this thesis to Sarah, Erin and Benjamin,  
and wish them to find their perfect path in life.



# Acknowledgments

My M.A. and Ph.D. advisor Stefan Müller provided my very first introduction into the wonderland of linguistics, back in 2007 when I took his class on morphology. Meeting him literally changed my life, and I owe him so much that it is ridiculous to even attempt to make a list (which I'm attempting nevertheless): He has been my gateway to formal linguistics, to formal syntax and to HPSG; has been an example of scientific discipline and intellectual honesty; and financed my Ph.D. thesis by hiring me on his scientific staff (which, trivial as it sounds, was not the least important). My gratitude to him is  $+\infty$ .

I am so honored that Anne Abeillé agreed to be my thesis advisor in 2017, despite my uttermost ignorance of French linguistics at that time. She is the origin of the strong bent of this book toward an experimental approach. I am immensely grateful for all the time she invested in me and this piece of work, as well as for the long hours of discussions she never seemed in a hurry to end. I have been able to ask her any silly question that came to my mind, and always got an answer.

She was also the one who suggested I apply for a binational cotutelle. Thanks to that, I had the opportunity to be part of the great Laboratoire de Linguistique Formelle at the Université Paris Cité. From this team, I want to thank especially Olivier Bonami, who directed the lab during my stay and always made me feel welcome and a full member of the lab. I am grateful for having met and worked with Barbara Hemforth, who taught me a lot about the methodology of experiments and statistical analyses. Many thanks to Danièle Godard and Berthold Crysmann, who gave me so much good advice regarding my research and the formalization of my analysis. I also wish to thank all members of the lab who supported my research: Céline Pozniak, Caterina Donati, Heather Burnett, Yair Haendler, Pascal Asmili; and the cheering group of Ph.D. students who helped me survive through the process<sup>1</sup>: Suzanne Lesage, Gabriel Thiberge, Bujar Rushiti, Quentin Dénigot, Saida Loucif and Antoine Simoulin.

At the Humboldt-Universität zu Berlin, which I joined in 2016, I wish to thank all the members of the Syntax Group for their support, especially Marc Felfe and Chenyuan Deng. I also thank Elisabeth Verhoefen and Paula Fritz Huechante, as well as Pia Knoeferle and her whole staff, with whom I really enjoyed talking

---

<sup>1</sup>Mostly, I must say, because they fed me. A lot.

## *Acknowledgments*

about our respective research. Most of this work was funded by the Deutsche Forschungsgemeinschaft (DFG) as I worked in the project *Long-distance dependencies in French*, with Guido Mensching, Franziska Werner and Esmā Tanis. I thank them all for their help and advice.

For some part of my time as a Ph.D. student, I was also employed at the Freie Universität Berlin. I have met so many people there during my years as a MA and as a Ph.D. student, who were of so much importance in my life, that I can't make a complete list. First of all I wish to thank Horst Simon and his whole crew (especially Tanja Ackermann and Christian Zimmer) for their warmth and support. I am very grateful to Felix Bildhauer, who had supervised my M.A. thesis with much consideration and whose doctoral dissertation has been an important early inspiration for my work. At the FU, I was also lucky enough to meet my dear colleague and friend Naomi Truan, who gave me very good advice for finding my way in the cotutelle maze. Finally, I wish to express a (very) big thank-you to Viola Auermann for her support and patience.

A special elbow bump goes to my Dr.uder Antonio Machicao y Priemer and to Aixiu An, my thesis "siblings". They made the journey so much more interesting and fun. Thank you for the countless hours of chatting. And just in general for everything.

A great deal of this work relies on the valuable data that I was able to collect. I cannot thank the French language itself for being so amazing, but I can at least thank all of those who participated in the (mostly unpaid) experiments, shared the experiments in order to help me, and did not even complain that rating strange sentences was such a boring task to do. I also thank the staff and colleagues who helped set up the studies.

Two thesis reporters, Rui Chaves and Dominique Sportiche, and two anonymous reviewers made excellent comments and remarks, which forced me to re-think several sections of the book, and helped improve the final manuscript. I wish to express my gratitude to the people who proofread this book: Maryvonne Gerin, Simon Luck, Carla Bombi, Janina Rado, Hannah Schlepner, Amir Ghorbanpour, Elliott Pearl, Brett Reynolds, Wilson Lui, Annie Zaenen and Felix Kopecky. It goes without saying that all remaining errors are mine.

Writing this book was not only a great intellectual adventure but also a tough time that I managed to overcome thanks to three very special people. Stephanie Gagne was always virtually here with me from the very start and until the very end in some way, and Zina Cohen was literally always here with me (talking about food and statistics, my two favorite topics). And of course, above all, I thank Antoine Laslier for his unconditional love and unconditional support.<sup>2</sup>

---

<sup>2</sup>Example (8.19b) is dedicated to you.



Finally, I want to thank my mother, because she's just the best. I'm convinced that no one has ever had such a wonderful, patient and supportive mother as I do. As my mother is never far from the rest of my family, I have to express my thanks going around the table: Jean-Jacques, Michèle, Dédé, Jeannine, Olivier, Ingrid, Jean-Christophe, Béatrice, Mathieu, Élise, Alexandre, Sophie, Julien, Aurélie, Paul, Mathias, Charlotte, Sarah, Paul, Emma, Jules, Antoine, Hortense, Victor, Claire, Raphaël and Benjamin. I love y'all to the moon and back.

The experiments reported in this book were approved by the CERES, (Conseil d'évaluation éthique pour les recherches en santé) of the University of Paris Descartes.

My work over the last year has been supported by the German Research Foundation (DFG) as part of the research program "Long-distance Dependencies in French: Comparative Analyses (HPSG and the Minimalist Program)", Guido Menzsching, Göttingen (ME 1252/14-1)/Stefan Müller, Berlin (MU 2822/9-1). It was also supported by a public grant overseen by the French National Research Agency (ANR) as part of the program "Investissements d'Avenir" (reference: ANR-10-LABX-0083). It contributed to the IdEx Université Paris Cité (ANR-18-IDEX-0001). Finally, some of this work has been conducted as part of a research position at the Freie Universität Berlin.



## Collaborative work

The corpus studies presented in this book have all been conducted with my supervisor Anne Abeillé. Barbara Hemforth also collaborated on the corpus study that we published in Abeillé et al. (2016).

The extraction of the data from the corpus was carried out by Anne Abeillé for the French Treebank, and by myself for Frantext. We agreed on the guidelines for the annotation. The annotation was almost entirely my work, but Anne Abeillé would help me decide uncertain cases. I am completely responsible for the statistical analysis, but I received useful comments from Barbara Hemforth, Anne Abeillé and many other researchers who discussed my work with me during many conferences and workshops. The final decision on the statistical methods and interpretation of the results remained my own.

The experiments have all been conducted with my supervisor Anne Abeillé, and many of them in collaboration with Barbara Hemforth and Ted Gibson.

For most studies, the materials were first constructed by me, and then discussed and modified with Anne Abeillé before we agreed on a final version. Sometimes, Ted Gibson constructed English material, which was then discussed and modified with our remarks, and translated into French by me or Anne Abeillé to construct a parallel experiment in French. I only present the French experiments in this work, but the interested reader will find a short discussion of the English experiments in Section 14.6 and is otherwise referred to Abeillé et al. (2020).

Internet experiments with acceptability judgment tasks were set up on the Ibex Platform by one of the Ph.D. students at the Laboratoire de Linguistique Formelle (Aixiu An, Céline Pozniak or myself) (Drummond 2010). Lab experiments were set up by Etienne Riou (speeded acceptability judgment), Céline Pozniak (eye tracking) and Aixiu An (self-paced reading).

I am completely responsible for the statistical analysis, but I received useful comments from Anne Abeillé, Ted Gibson, Barbara Hemforth, Céline Pozniak, Yair Haendler and many other researchers who discussed my work with me at many conferences and workshops. The final decision on the statistical methods and interpretation of the results remained my own.



## **Part I**

# **Subextraction from subjects: State of the art**



# 1 Introduction

French is a language with a relatively fixed word order. Declarative sentences in French typically display a SVO order. Though in some respects it is more free than English word order, it is less free than German word order – to name just a few neighboring languages which otherwise have many similarities. Obviously, however, word order in any language is necessarily constrained in some ways. In this work, I will discuss some constraints on a non-declarative word order that is usually called “extraction”, or more technically referred to as “unbounded dependency”. In the 1960s, John R. “Haj” Ross came up with a very pictorial and poetic word to refer to this kind of constraints, calling them “islands”. The idea underlying this concept is that some structures are units out of which it is very difficult, if not utterly impossible, for constituents to escape. Islands are nowadays one of the most important concepts in syntax. The questions that I am addressing in this work are the following: Do the constraints on locality really have a syntactic origin? Are these constraints universal, i.e. cross-linguistically valid, and if so, what does this reveal about human language?

In this work, the discussion mostly concentrates on subject islands, that is on non-declarative positions of elements that syntactically depend on the subject and may or may not have the possibility to appear outside of the subject. The empirical studies that I present are on French. But the implications of what I discuss go beyond the scope of French, or even of subject islands. I will argue that the mechanisms at play in extractions out of the subject in French have deep roots in our cognitive capacities and in the way we as humans treat information. Therefore it is not specific to a particular language or to syntactic subjects.

## 1.1 Some definitions

Before we turn to the topic of subextraction from subjects, it is necessary to define some core concepts used in this work. In “extractions”, one element occupies a position at the leftmost edge of a clause, as in (1.1), where the relevant element is italicized. In this respect, extraction differs from scrambling, which is the free permutation of (verbal) dependents inside a clause, as shown in the German example (1.2) and in the French example (1.3).

## 1 Introduction

- (1.1) a. SVO declarative:  
I recently saw *a woman* with a parrot on her shoulder.
- b. extraction:  
*Who* did you recently see with a parrot on her shoulder?
- c. extraction:  
*Who* did Mark pretend he saw with a parrot on her shoulder?
- (1.2) a. Gestern hielt Kristin eine bewegende Rede bei der Demo.  
yesterday held Kristin a moving speech at the protest
- b. Gestern hielt Kristin bei der Demo eine bewegende Rede.  
yesterday held Kristin at the protest a moving speech
- c. Gestern hielt eine bewegende Rede Kristin bei der Demo.  
yesterday held a moving speech Kristin at the protest
- d. Gestern hielt bei der Demo Kristin eine bewegende Rede.  
yesterday held at the protest Kristin a moving speech
- e. Gestern hielt eine bewegende Rede bei der Demo Kristin.  
yesterday held a moving speech at the protest Kristin  
'Yesterday, Kristin gave a moving speech during the protest.'
- (1.3) a. (Hier) Capucine a (hier) donné (hier) un livre  
yesterday Capucine has yesterday given yesterday a book  
(hier) à son fils (hier).  
yesterday at her son yesterday  
'Capucine gave a book to her son (yesterday).'
- b. (Hier) Capucine a (hier) donné (hier) à son fils  
yesterday Capucine has yesterday given yesterday at her son  
(hier) un livre (hier).  
yesterday a book yesterday  
'Capucine gave her son a book (yesterday).'

Extraposition, i.e. the non-canonical position of an element at the rightmost edge of a clause, is also treated as extraction by some scholars, but it is bound to a clause and cannot form long-distance dependencies (Guéron 1980), that is why I will not talk about these cases in the present work. Some other phenomena are sometimes treated as “movement”, and therefore as a kind of extraction (e.g. the canonical position of verbs in main clauses in German), but again, it is not what I will call “extraction” in the following sections.



I will refer to the canonical position of the extracted element as the “gap”, and identify it in the examples with an underscore (  ). This notation is common in linguistic works, and very practical in helping the reader identify the kind of dependency that is meant without too much explanation, especially in very complicated examples. Additionally, the gap will be coindexed with the extracted element, which helps identify the actual extraction at play, especially when there are multiple extractions.<sup>1</sup> However, this annotation should not be interpreted as presupposing that extraction of a constituent leaves anything at its canonical position. Traditional accounts of generative grammar assume that the extracted element leaves behind a “trace” at the position where it is taken to be base-generated in the deep structure. Similarly, in HPSG, extraction is sometimes analyzed with empty categories, and thus the assumption is that there is an empty element at the canonical position of the extracted element. Nevertheless, I wish to make clear that it is not what the notation means here. At the end of this work, I propose an HPSG analysis that does not use empty categories (Sag & Fodor 1994, Sag & Godard 1994, Sag et al. 2007, Sag 2010).

I will refer to the position of the extracted element as the “filler”. As said previously, this position is at the leftmost position of a clause. The relation between the filler and the gap will be termed “filler-gap dependency”. This term will sometimes be applied to structures in which the filler is not realized. What “filler-gap dependency” means in these cases is that the sequence of words provides cues to the addressee that they have to identify a missing element, i.e. a gap, in the rest of the utterance. For example, in (1.4), the presence of the word *you* signals the beginning of a relative clause, and the reader will start looking for the gap, even though there is no actual filler in the relative clause.<sup>2</sup>

(1.4) the woman you ... saw with a parrot on her shoulder

I will make a distinction between “short-distance” and “long-distance” filler-gap dependencies. Short-distance dependencies do not cross the boundary of the clause in which the gap is directly situated. For example, (1.5a) is a short-distance dependency. In long-distance dependencies on the other hand, the dependency crosses one or more clause boundaries. Example (1.5b) is a long-distance dependency, because the filler is not at the leftmost position of the embedded clause,

---

<sup>1</sup>Most of the time, the coindexation also means that both the missing element and the extracted element refer to the same semantic variable. However, as we will see later, complementizers are not per se extracted. Nevertheless, I will use coindexation in examples involving complementizers for the sake of readability.

<sup>2</sup>Notice that *the woman* is not the filler, but the antecedent of the relative clause. These details will be discussed extensively in the rest of the book, and especially in the formal analysis.

## 1 Introduction

but at the leftmost position of the matrix clause. By definition, long-distance dependencies hence involve at least a matrix and an embedded clause.

- (1.5) a. Who<sub>i</sub> did you recently see <sub>-i</sub> with a parrot on her shoulder?  
b. Who<sub>i</sub> did Mark pretend [that he saw <sub>-i</sub> with a parrot on her shoulder]?

When extraction takes place out of a phrase, I will refer to it as “subextraction”. For example, (1.6) is subextraction from a direct object. The main topic of this work is subextraction out of subjects, i.e. extractions in which only part of the NP subject, part of the verbal subject or part of the sentential subject is extracted.

- (1.6) the parrot [whom<sub>i</sub> I saw [the owner of <sub>-i</sub>]<sub>NP</sub> running away]

## 1.2 Extractions in French

Three extraction constructions are discussed in depth in this work: relative clauses, interrogatives, and *it*-clefts. In French, relative clauses are noun modifiers that are introduced either by a relative word as in (1.7b) or by a filler phrase containing a relative word as in (1.8b).

- (1.7) a. canonical word order:  
Nous avons parlé *de Gaetan* hier.  
we have talked of Gaetan yesterday  
‘We talked about Gaetan yesterday’  
b. relative clause:  
Gaetan, [dont<sub>i</sub> nous avons parlé <sub>-i</sub> hier]  
Gaetan of.which we have talked yesterday  
‘Gaetan, whom we talked about yesterday’
- (1.8) a. canonical word order:  
Nous avons parlé *du perroquet d’ Agate* hier.  
we have talked of.the parrot of Agate yesterday  
‘We talked about Agate’s parrot yesterday’  
b. relative clause:  
Agate, [[du perroquet de qui]<sub>i</sub> nous avons parlé <sub>-i</sub> hier]  
Agate of.the parrot of who we have talked yesterday  
‘Agate, whose parrot we talked about yesterday’

The use of a relative word to build a relative clause is common in European languages, though not very common cross-linguistically. Comrie & Kuteva (2013) list only 12 to 13 languages using this morphosyntactic strategy. This, however, is the only option in French. The gap strategy exemplified in (1.4) is not available:

- (1.9) \* le perroquet [tu as vu \_ hier]  
 the parrot you have seen yesterday

Clefts in French are either presentational (and similar to *here*-clefts in English) or focalizing (and similar to *it*-clefts in English). I will refer to them as *c'est*-clefts. Both are constructions following the pattern [*ce* ('it') + copula + XP + S]. The XP is either the referent introduced in presentationals, like (1.10a), or the focused element in focalizing *c'est*-clefts, as in (1.10b).

- (1.10) a. C' est le perroquet [dont<sub>i</sub> nous avons parlé \_<sub>i</sub> hier].  
 it is the parrot of.which we have talked yesterday  
 (*pointing to the parrot*)  
 'Here is the parrot whom we talked about yesterday.'
- b. C' est du perroquet d' Agate [que<sub>i</sub> nous avons parlé \_<sub>i</sub>  
 it is of.the parrot of Agate that we have talked  
 hier] (, pas du perroquet de Gaetan).  
 yesterday not of.the parrot of Gaetan  
 'It's Agate's parrot whom we talked about yesterday (not  
 Gaetan's parrot).'

The last element of the pattern (S) is the one showing extraction, with a relative word or a relative phrase at its left edge. It is hence very similar to a relative clause, but I will argue in my HPSG analysis that it is not always one. I leave aside constructions with *il y a*, like (1.11), which are often referred to as clefts as well in the literature (Lambrecht 1994, Doetjes et al. 2004, Karssenbergh & Lahousse 2018) and also involve an extraction.

- (1.11) (Karssenbergh & Lahousse 2018: 517)  
 Il y a des enfants [qui<sub>i</sub> \_<sub>i</sub> aiment le fromage].  
 it there has DET children who like the cheese  
 'There are some children who like cheese.'

I also leave aside *wh*-clefts (1.12a) and their French counterparts (1.12b), which are different in terms of syntax and function.

## 1 Introduction

- (1.12) a. What the woman had on her shoulder was a parrot.  
b. Ce que mes enfants aiment, c' est le fromage.  
it that my children like it is the cheese  
'What my children like is cheese.'

Whereas extraction in relative clauses and *it*-clefts is mandatory, it is optional in interrogatives (Obenauer 1976), but see Section 11.4 for the potential pragmatic factors implied by extracted vs. in situ *wh*-words.

- (1.13) a. [De qui]<sub>i</sub> avez - vous parlé <sub>-i</sub>?  
of who have you talked  
'Whom did you talk about?'  
b. Vous avez parlé de qui?  
you have talked about who  
'You talked about whom?'

Further constructions involving extraction are not discussed in this work, even though of course they are assumed to be affected by the island constraints, just like any extraction. For example, French also has complement fronting (1.14a), exclamatives (1.14b), comparative correlatives (1.14c), topicalization (1.14d), concessives (1.14e) and so-called *tough* constructions (1.14f).<sup>3</sup>

- (1.14) a. (Abeillé et al. 2008: 306)  
[Huit ans]<sub>i</sub> je devais avoir <sub>-i</sub>.  
eight years I must.PAST have.INF  
'Eight years, I must have had.'

---

<sup>3</sup>For an HPSG analysis of complement fronting in French, see Abeillé et al. (2008). For a typology and HPSG analysis of exclamatives in French, see Marandin (2008). For an HPSG analysis of comparative correlatives in English, French and other languages, see Abeillé & Borsley (2008). See also Godard (1988: 40–42) and Cinque (1990: 106–107) on some infinitival complements in French that involve an unbounded dependency without extraction in French (and an overview of this same construction in other Romance languages in Mensching 2000):

- (i) (Mensching 2000: 76)  
Qui crois - tu être intelligent?  
who think you be.INF intelligent  
'Who do you believe to be intelligent?'  
(ii) \*Tu crois Richard être intelligent.  
you believe Richard be.INF intelligent  
'You believe Richard to be intelligent.'

### 1.3 Some remarks on subject extraction

- b. (Marandin 2008: 438)  
[Quel chapeau]<sub>i</sub> il portait <sub>-i</sub> !  
what hat he wore  
'What a hat he was wearing!'
- c. (Abeillé & Borsley 2008: 1148)  
Plus je lis <sub>-</sub>, plus je comprends <sub>-</sub>.  
more I read more I understand  
'The more I read, the more I understand.'
- d. [De tout cela]<sub>i</sub>, nous reparlerons <sub>-i</sub> demain.  
of all that we talk.FUTURE tomorrow  
'About all this, we will talk tomorrow.'
- e. Aussi difficile [que<sub>i</sub> ce problème soit <sub>-i</sub>], tu pourras  
as difficult that this problem be you can.FUTURE  
le résoudre.  
MASC.ACC resolve  
'As difficult as this problem may be, you'll be able to solve it.'
- f. une nouvelle<sub>i</sub> [difficile à croire <sub>-i</sub>]<sub>AdjP</sub>  
a news hard at believe.INF  
'news (that is) hard to believe'

An overview of all unbounded dependencies can be found in Godard (1988: Section 1.2.2) for French and in Sag (2010: Chapter 2) and Chaves & Putnam (2020: Chapter 2) for English.

Notice that combinations are of course possible: a sentence may display several extractions, and even extraction out of extracted elements – although this is subject to constraints (see below). Also, one single filler (or equivalent) may correspond to several gaps, see example (1.15).

One filler may be coindexed with more than one gap (which can, but must not, be coindexed with each other).

- (1.15) (Chaves & Putnam 2020: 7)  
There's no engine [[which]<sub>i</sub> Geoff can't disassemble <sub>-i</sub>, clean <sub>-i</sub>, and put <sub>-i</sub> back together without disparaging <sub>-i</sub> or complaining about <sub>-i</sub>].

### 1.3 Some remarks on subject extraction

The subject is extracted in French with the relative word *qui*. Subject-*qui* and *que* are two relative words that are traditionally considered complementizers rather

## 1 Introduction

than pronouns. On page 47, I come back to the distinction between complementizers and pronouns.

Because French is an SVO language with a relatively fixed subject-verb order (subject-verb inversion is only allowed in very specific cases, see Bonami & Godard 2001), the filler in short-distance dependencies is located just before the subject. When the *wh*-phrase is the subject, it is impossible to know whether it is extracted (i.e., the *wh*-phrase is followed by a gap) or in situ. In the context of this book, I assume, however, that the subject undergoes extraction, as illustrated by (1.16), for several reasons.

- (1.16) les enfants [qui<sub>i</sub> –<sub>i</sub> aiment le fromage]  
the children who like the cheese  
'children who like cheese'

I mention below some arguments that apply to French, but the interested reader should refer to Chaves & Putnam (2020: 28–32) for further cross-linguistic arguments.

### 1.3.1 Extraction of the subject in relative clauses

First, there is no Indo-European language with postnominal relative clauses with relative words in situ.<sup>4</sup> Why would subjects be an exception to this rule? Hence I assume that extraction in relative clauses is obligatory.

The second argument comes from the so-called *que-qui*-rule (see a.o. Kayne 1974, 1976, Pesetsky 1982, Koopman & Sportiche 2014). The relative word *qui* is used to relativize the subject, as in (1.16). But in long-distance dependencies with an intervening complementizer *que*, it becomes obvious that *qui* here is only a variant of *que* that appears before an extracted subject. In example (1.17b), the relative word is *que* (and not *qui*, even though the subject is relativized), while *qui* can only be introducing the sentential complement of *pense* ('think'). Sentential complements are introduced by *que* if there is no subject extraction involved.

- (1.17) a. Je pense que tes enfants aiment le fromage.  
I think that your children like the cheese  
'I think that your children like cheese'

---

<sup>4</sup>For Downing (1978), the fact that relative pronouns are never realized in situ belongs to the universal properties of relative clauses. However, de Vries (2002: 37) mentions a few languages from West Africa in which this rule is not true. If I correctly understand their findings, both are talking about relative words (in contrast to resumptives) in general (e.g. not about relative pronouns in contrast to complementizers).

- b. les enfants [que<sub>i</sub> je pense [qui -<sub>i</sub> aiment le fromage]]  
 the children that I think that like the cheese  
 ‘the children who I think that (they) like cheese’

Because *qui* is the relative word in short-distance dependencies, we must assume that these dependencies involve extraction. The *que-qui* rule will be described and analyzed in more detail in Section 16.2.

### 1.3.2 Extraction of the subject in interrogatives

One type of French interrogatives is formed with *est-ce que* (lit. ‘is it that’), which is analyzed by Abeillé et al. (2012) as a complementizer. Interrogatives in *est-ce que* cannot have their interrogative word in situ, as the following example shows:

- (1.18) a. Tu vas où?  
 you go where  
 b. Où<sub>i</sub> est - ce que tu vas -<sub>i</sub>?  
 where is it that you go  
 c. \*Est - ce que tu vas où?  
 is it that you go where  
 d. \*Tu vas où<sub>i</sub> est - ce (que)?  
 you go where is it that  
 ‘Where are you going?’

Since interrogatives with *est-ce que* can be used to question the subject, there must be extraction in (1.19). And if extraction is possible in these interrogatives, it is presumably possible in interrogatives in general.

- (1.19) Qui<sub>i</sub> est - ce qui -<sub>i</sub> aime le fromage?  
 who is it that likes the cheese  
 ‘Who likes cheese?’

Since in situ questions are allowed in French, it follows that they must be possible to question the subject. Therefore, we must assume that the example (1.20) is syntactically ambiguous.

- (1.20) a. Qui aime le fromage?  
 who likes the cheese  
 b. Qui<sub>i</sub> -<sub>i</sub> aime le fromage?  
 who likes the cheese  
 ‘Who likes cheese?’

## 1.4 A definition of “islands”

There are lots of “islands” or “syntactic islands” identified in the literature – rightly or wrongly. I invite the reader who wants a broader overview of all these island types to consult Chaves & Putnam (2020). In the present book, I focus exclusively on a particular type called subject island. This being said, I believe that many of the findings I present have some significance for the general theory on islands. Limiting the scope of this work to a particular case of islands was necessary in order to account for its complexities and nuances. Even so, and as the reader will realize, I am far from exhausting the question of extractions out of the subject.

I will first define what I mean by islands, before turning to the particular case investigated in this work.

### 1.4.1 The notion of “islands” over time

It has been noticed that extraction cannot cross certain boundaries, even though there is virtually no limit to the linear length of filler-gap dependencies. For example, in coordinations, extraction of one of the conjuncts is impossible, as illustrated by (1.21).

- (1.21) a. \* Who did [your father and  $-_i$ ] buy a parrot?  
b. \*  $Qu_i$ ’ est - ce que tes enfants aiment [le fromage et  $-_i$ ]?  
what is it that your children like the cheese and  
‘What do your children like cheese and?’

This led linguists, starting with the seminal work of Ross (1967)<sup>5</sup>, to postulate syntactic constraints on extraction, called “islands”. The constraint illustrated by example (1.21) is referred to as the Coordinate Structure Constraint.

There is currently still a debate regarding island effects in constructions without extraction, especially in languages in which *wh*-questions do not necessarily require filler-gap dependencies (like French), or never involve filler-gap dependencies (like Mandarin Chinese, see Huang 1982, Aoun & Li 1993, Lu et al. 2020 a.m.o.). Although in the present book I focus on islands in the context of filler-gap dependencies, I come back to the question of *wh*-in situ interrogatives in Section 11.4.

---

<sup>5</sup>An anonymous reviewer traces this discussion back to Chomsky (1964).



In their first definition by Ross, island constraints were syntactic in nature, and a violation of island constraints was considered to lead to ungrammaticality.<sup>6</sup> Even though the discussion about islands mostly originates from observations concerning extraction constructions, islandhood did not only play a role in extraction, but was “the maximal areas in which syntactic process of a designated sort could apply” (Ross 1987: 258). Very soon after however, Erteschik-Shir (1973) proposed that islands are not caused by syntactic factors, but have a functional (discourse-based) explanation. This proposal has been followed by processing (Kluender 1998) or semantic accounts (Szabolcsi & Zwarts 1990). This island constraints are no longer considered to be only a matter of syntax. Furthermore, the lively discussion of the phenomenon brought to the fore novel data from various languages, including exceptions to some of Ross’s original islands, and to some other islands added later to list of island structures. Cinque (1990) and Rizzi (1990) introduced a distinction between “strong” and “weak” islands (Kluender 1998, Szabolcsi 2006). In a nutshell, strong islands correspond to the original definition of islands that block any kind of extraction. Weak islands, on the other hand, are cases in which only the extraction of some constituents is ruled out.<sup>7</sup> Some also consider violations of weak islands to be more acceptable than violations of strong islands, a conception that diverges a lot from the original definition of islands. Almeida (2014) even talks about “subliminal islands” – (weak) island configurations that do not lead to unacceptability in a given language but still display a disadvantage when compared to another similar non-island structure. However, multiplying the degrees of islandhood with notions like “weak” or “subliminal” islands is a move away from what motivated the notion of islands in the first place, which is that some configurations are not possible even though nothing seems to prevent them. The issue is not the preference for one configuration over another, but the fact that not everything is possible in a given language and that some of these impossible things are particular to extractions (and perhaps also to binding).

---

<sup>6</sup>Notice that, for Ross (1967), islands did not necessarily reflect universal constraints. In his original definition, islands could be language-specific.

<sup>7</sup>For Cinque (1990), the distinction between strong and weak islands was that extraction (without a resumptive pronoun) was never allowed out of strong islands while extraction of PPs (but not of DPs) was allowed out of weak islands. Another definition can be found in Huang (1982) and Chomsky (1986), who draw the line between argument extraction (weak islands allow the extraction of arguments, but strong islands do not) and adjunct extraction (extraction of adjuncts is never allowed out of any island). In general, though, scholars agree that strong islands are “absolute” (they are always valid) while weak islands are “selective” (some elements are sensitive to the island and some are not). See Szabolcsi (2006) for an overview of the debate around weak islands.

### 1.4.2 Definition adopted in this work

In this work, I adopt a definition of islands closer to the one formulated by Ross, but without postulating that islands are necessarily syntactic in origin. A more complete defense of this definition can be found in Liu et al. (2022).

An island is an extraction construction whose constructs, in some systemic manner, are considered unacceptable by most speakers. Systematicity is an important factor in this definition: it is not an isolated example, rather it is possible to identify a group of examples that are similar in form and similarly unacceptable. Extraction is an important factor as well: it must be possible to construct acceptable examples that differ from the unacceptable ones only by the absence of extraction. If this condition is not met, the unacceptability is not due to the extraction, but can come from any feature of the sentence, and it is not caused by the existence of an island (Chaves & Putnam 2020: 77–78).

Thus, stating that subjects are islands means that examples involving extractions out of a subject are systematically considered unacceptable by most speakers, even though examples with a close propositional and lexical content with no extraction would be judged acceptable.

Islands can be language-specific, although most researchers implicitly (and sometimes explicitly) take them to be universal constraints.

### 1.4.3 Identifying islands through empirical work

The main issue, therefore, is to find out what makes it possible to identify an island. It is generally assumed that the ungrammaticality of a sentence goes hand in hand with its unacceptability. This is why great importance is given in this work to experimental data, under the assumption that the speakers of a language are the real experts as to what structures are allowed or not in a language. There are of course well-known exceptions in experimental linguistics, such as grammatical illusions: sentences that many speakers spontaneously perceive as acceptable, even though they are ungrammatical (e.g., from an agreement point of view in the case of agreement attraction). It seems to me, however, that a sentence cannot be both an island violation and a grammatical illusion, since by definition, islands are configurations that are systematically ill-formed even though nothing seems to prevent them from being well-formed. In grammatical illusions, the reason for their ill-formedness is easy to identify (so easy that we judge it surprising that speakers accept them).

From the experimental point of view, Sprouse (2007a) and subsequent work by Sprouse and his colleagues have proposed a superadditivity design as a diagnostic for islandhood. I will describe this design in detail in Section 6, but the idea,

in a nutshell, is to construct and test minimal pairs comparing island structures with non-island structures, in extraction and non-extraction conditions. Participants should give lower ratings to sentences with an extraction in an island configuration than to sentences in a non-island configuration or without extraction. Although very useful, this diagnostic only applies to experimental data. I will indeed use Sprouse's (2007a) superadditivity design in a series of experiments that I present in Part II and describe the superadditivity effects observed in these experiments as "island effects". Of course, this experimental method can only deliver a good diagnostic for islandhood if the investigator was successful in eliminating the impact of unrelated factors. Thus a superadditivity effect is not necessarily synonymous with islandhood.

I should add that we expect native speakers not to produce sentences that violate an island constraint (or very marginally, as performance errors). This is why, in addition to experimental data, I look at islands in speech production. In Part II, I present a series of corpus studies on well-edited written French (newspaper articles and texts from French literature), in which I expect errors to be rare.

## 1.5 The structure of this book

Part I of the book introduces the previous theoretical approaches to what is generally known as "subject islands". In Part II, we move on to the empirical data on French: I present a series of corpus studies and experiments that help understand the phenomenon. Finally, Part III proposes a formal HPSG analysis of extractions, short- and long-distance dependencies and extraction out of the subject in French.

*Part I:* In Chapter 2, I present the three general kinds of explanations based on syntax. I explain that, for traditional syntactic accounts, extraction out of the subject is not only dispreferred but is ruled out by syntax. Scholars in the syntactic tradition do not agree on the reasons that cause subject islands, but they agree that these reasons are universal and are based on innate properties of language. Some syntactic accounts treat subject islands and adjunct islands (the ban on subextraction out of adjuncts) as a single phenomenon (e.g. Huang 1982) and claim that only extraction out of complements is acceptable. In other syntactic accounts, subjects are considered special because they are in the Specifier position, which is already at the edge of the phrase (e.g. Chomsky 2008). Finally, a third kind of syntactic account proposes that subjects are the result of the movement of some elements to the subject position, and that any movement out of a moved

## 1 Introduction

element is ruled out (e.g. Uriagereka 2011). I also explore the French data and previous proposals of syntactic analyses for French subject islands. In Chapter 3, I present accounts based on processing. In general, work on the processing of filler-gap dependencies shows that it is easier to parse shorter dependencies between the extracted phrase and the gap. If this is the case, then subextraction from (preverbal) subjects should be easier to process than subextraction from objects because the distance is shorter. But there have also been processing-based accounts of subject islands: Klunder (2004) have theorized that complex subjects are dispreferred for processing reasons and that therefore subextraction is unexpected. In Chapter 4, I discuss discourse-based accounts of islands in general. In a nutshell, these accounts assume that extraction makes an element more salient, and propose that some constituents cannot be made salient and thus cannot be extracted (e.g. Erteschik-Shir 1973). I then present a new proposal based on information structure, called the Focus-Background Conflict (FBC) constraint, which states that part of a backgrounded constituent cannot be focalized. Contrary to previous discourse-based accounts, this constraint predicts that extraction out of the subject will show cross-constructions differences based on the function of the construction. Some constructions are indeed focalizing (like interrogatives and *it*-clefts) and some are not (like relative clauses).

*Part II:* After this, I present eight corpus studies and 16 experiments on extraction out of the subject. The corpus studies are based on two different corpora of written French: the French Treebank (Abeillé et al. 2003, 2019) and Frantext (<https://www.frantext.fr/>). Most of the experiments used acceptability judgment tasks, one is a speeded acceptability judgment task, one is a self-paced reading task and one is an eye tracking experiment. The empirical data on relative clauses confirm Godard's (1988) intuitions: relativization out of the subject is very frequent and generally accepted by native speakers. In the corpus we observe a clear distinction between subextraction out of subjects in relatives and in interrogatives. In fact, there is not a single example of extraction out of the subject in interrogatives, a result supported by the experimental data on interrogatives in which participants rejected extractions out of the subject. One experiment on *c'est*-clefts shows more nuanced results, but extractions out of the subject seem problematic there as well. Two experiments investigate extraction out of infinitival subjects. Subextractions from infinitival subjects received surprisingly high acceptability judgments, even though they were dispreferred compared to extrac-

tions out of infinitival complements. Comparing this empirical evidence with the different accounts on subject islands, I conclude that the FBC constraint explains the data best, especially the strong distinction between relative clauses on one hand and interrogatives and *it*-clefts on the other hand.

*Part III:* Part III offers an HPSG analysis of the FBC constraint. In Chapter 15, I first discuss the FBC constraint's implications in some detail. In Chapter 16, I describe a small fragment for the analysis of French sentences in HPSG, explaining how syntax, semantics and information structure are represented in HPSG and interact with each other. I then present the three main constructions involving extraction that I explored in the empirical parts: interrogatives, relative clauses and *c'est*-clefts. In Chapter 17, I formalize the FBC constraint within my HPSG fragment for French. Finally, in Chapter 18, I present the analysis of verbal and sentential subjects and of subextractions out of verbal and sentential subjects.



## 2 Syntactic approaches to the “Subject Condition”

The first and still best-known approaches to the phenomenon known as “subject island” posit that the ban on extraction out of subjects – sentential and verbal subjects and/or NP subjects – is caused by their syntactic properties. In this chapter, I will present Ross’s (1967) original constraint for sentential subjects, and the subsequent early analysis by Chomsky (1973) for all subjects, which have been very influential. It is unfortunately impossible to review all syntactic approaches to the subject island constraint: there have been an abundance of different analyses. I will therefore only discuss three main lines of explanation that have been adopted over the years. Each one is based on one of the properties of subjects: not being a complement (those approaches usually treat the subject island together with the adjunct island<sup>1</sup> as a single phenomenon), being a specifier, and having to move to Spec,TP/IP. Then I will turn to the major criticisms that have been brought against syntactic approaches. The major one is that it has been well documented that extraction out of the subject is possible in many languages (Stepanov 2007). Of particular interest for this study is the work on French by Godard (1988), which has shown that subextraction from subjects is possible with the relative word *dont*. I will present the French data, the debate around French,

---

<sup>1</sup>The adjunct island was not part of Ross’s original islands, but it has been associated with the island constraints principally by Cattell (1976) (as the “Adjunct Island Condition”). It is claimed to be a strong island.

- (i) a. (Longobardi 1985: 168)  
\* a person<sub>i</sub> who<sub>i</sub> I think that [while informing  $\rightarrow_i$  about my work] I could be embarrassed.
- b. (Godard 1988: 43)  
\* [une] décision<sub>i</sub> [que<sub>i</sub> vous savez bien que [s’ ils prenaient  $\rightarrow_i$ ] nous n’  
a decision that you know well that if they take.COND we NEG  
aurions d’ autre choix que de partir d’ ici]  
have.COND of other choice that of leave.INF of here  
‘a decision that you know very well that if they make (it) we would have no other choice than departing’

## 2 Syntactic approaches to the “Subject Condition”

and explain how Tellier (1990, 1991) and Heck (2009) have tried to account for these data while still maintaining the subject island constraint for French. Finally, I will give a brief historical survey on how the subject island constraint has been treated in HPSG.

### 2.1 The Sentential Subject Constraint of Ross (1967)

Ross appears to have been the first linguist to notice that extraction<sup>2</sup> out of subjects is limited by certain constraints in English. His rule is reproduced in (2.1). (Ross 1967: 243)

- (2.1) No element dominated by an S may be moved out of that S if that node S is dominated by a NP which itself is immediately dominated by S.

The Sentential Subject Constraint accounts for the visible contrast between extraction out of sentential subjects and out of sentential complements, as illustrated in (2.2).

- (2.2) (Ross 1967: 241)
- a. The teacher [ $\text{who}_i$  the reporters expected [that the principal would fire  $_{-i}$ ]] is a crusty old battleax.
  - b. \* The teacher [ $\text{who}_i$  [that the principal would fire  $_{-i}$ ] was expected by the reporters] is a crusty old battleax.

In order to understand why (2.1) correctly rules out (2.2b), it is necessary to know that Ross analyzes sentential complements as NPs directly embedding an S, as shown in Figure 2.1 for a sentential complement and in Figure 2.2 for a sentential subject.

In (2.2a), whose syntactic tree is given in Figure 2.3 on page 22, the complement (the NP embedding the *that*-clause) is embedded under VP, thus not directly embedded under the S of the relative clause. Therefore, the Sentential Subject Constraint does not apply, the sentence is grammatical and thus felicitous.

In (2.2b), whose syntactic tree is given in Figure 2.4 on page 23, the subject (again an NP embedding the *that*-clause) is directly embedded under the S of the relative clause. The Sentential Subject Constraint is therefore violated, and the sentence is ungrammatical.

Ross also notices that the Sentential Subject Constraint is in competition with a “general output condition on performance” reproduced in (2.3).

---

<sup>2</sup>In his terminology – following a transformational approach – *reordering*.



2.1 The Sentential Subject Constraint of Ross (1967)

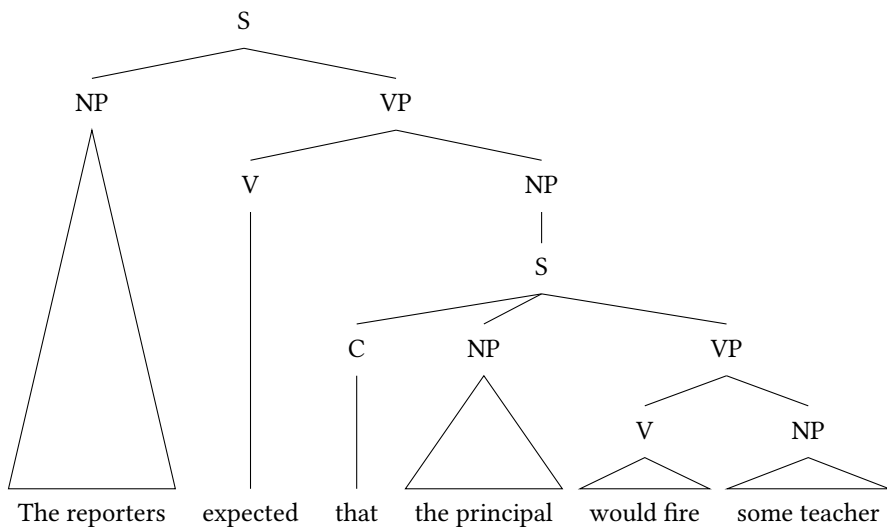

Figure 2.1: Syntactic tree for “The reporters expected [that the principal would fire some teacher].” (Baseline of extraction in (2.2a)) according to Ross’s analysis

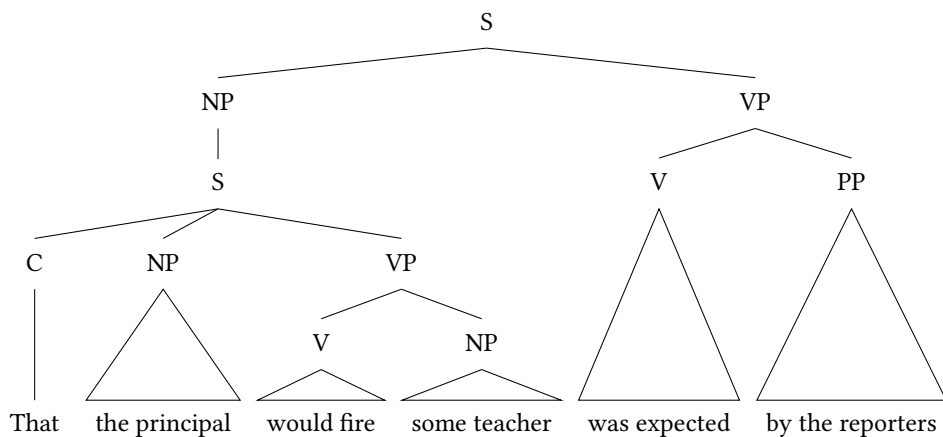

Figure 2.2: Syntactic tree for “[That the principal would fire some teacher] was expected by the reporters.” (Baseline of extraction in (2.2b)) according to Ross’s analysis

## 2 Syntactic approaches to the “Subject Condition”

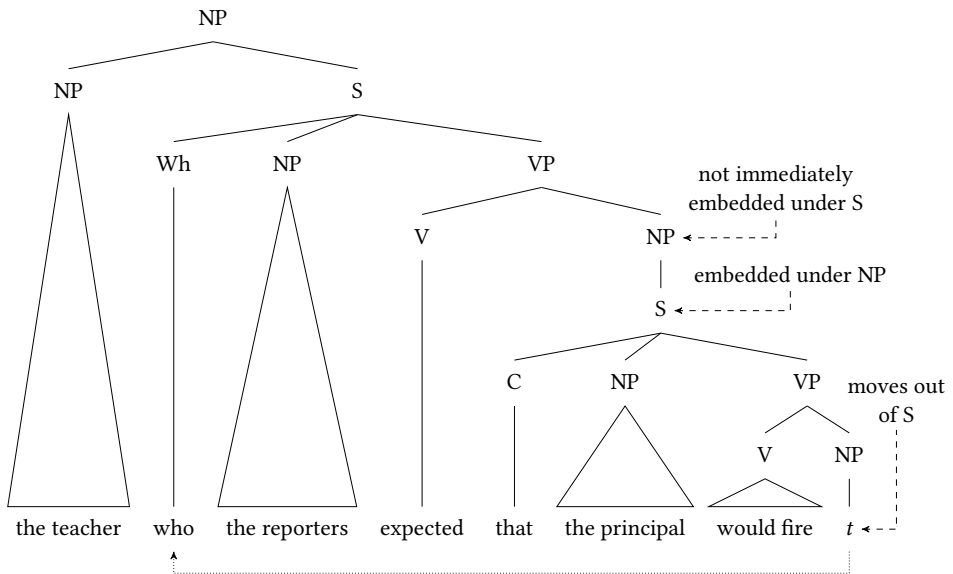

Figure 2.3: Syntactic tree for “the teacher [who<sub>i</sub> the reporter expected [that the principal would fire <sub>-i</sub>]]” according to Ross’s analysis

- (2.3) Grammatical sentences containing an internal NP which exhaustively dominates S are unacceptable unless the main verb of that S is a gerund. (Ross 1967: 251)

In (2.3), “internal” means that the element is neither at the beginning nor final. In this respect,  $[[\text{that the principal would fire}]_S]_{NP}$  in (2.2b) violates (2.3), because it is neither at the beginning nor end of the sentence, and because its verb is finite. Any subextraction from a finite sentential subject will per definition fall within this case, because Ross analyses sentential subjects as being S immediately dominated by an NP, and because the sentential subject will necessarily stand between the filler and a verb. However, Ross makes a clear distinction between the unacceptability caused by the violation of (2.3) and the ungrammaticality caused by the violation of (2.1). For him, ungrammatical sentences, unlike unacceptable ones, are “beyond intonational help” (Ross 1967: 247). Rule (2.3) was designed to account for the unacceptability of examples like (2.4b).

- (2.4) a. I told [a man who had a kind face] [that we were in trouble].  
 b. (Ross 1967: 53)  
 ? I told [that we were in trouble] [a man who had a kind face].

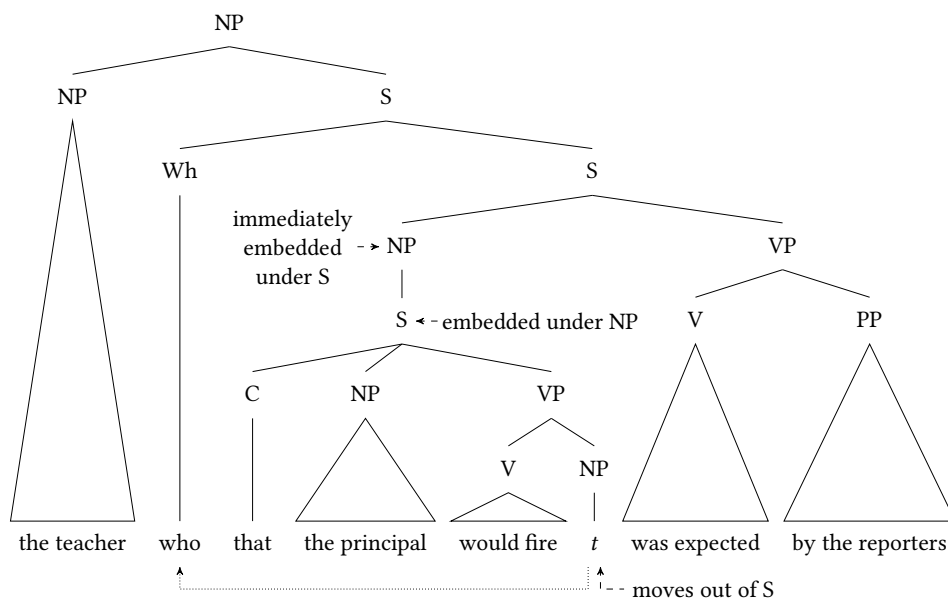

Figure 2.4: Syntactic tree for “the teacher [who<sub>i</sub> the reporters expected [that the principal would fire <sub>-i</sub>]]” according to Ross’s analysis

It is not clear why Ross does not consider (2.2a) unacceptable, given that it seems to violate (2.3) too, but the rule in (2.3) certainly does not account for the contrast noticed between (2.2b) and (2.2a).

## 2.2 The Subject Condition: subextraction from subject NPs

Ross’s Sentential Subject Constraint was very soon extended to all kinds of subjects, including NP subjects.<sup>3</sup> This is what is usually meant by “the Subject Island” constraint in the literature. According to Erteschik-Shir (1973: 158), the first proposal to extend the Sentential Subject Constraint to subject NPs was made by Horn (1972).

<sup>3</sup>Yet, Ross (1967) explicitly disagreed with this, because it made false predictions in his opinion. He gives the following example:

(i) (Ross 1967: 242)

[Of which car]<sub>i</sub> were [the hoods <sub>-i</sub>] damaged by the explosion?

This evidence has been dismissed by Chomsky (2008) as being extraction out of the subject of a passive, thus out of an underlying object, see below.

## 2 Syntactic approaches to the “Subject Condition”

The contrast between subject NPs and object NPs is often brought up as evidence that there is an “island effect” when subextracting from subjects. The extracted element is a PP dependent of the noun.<sup>4</sup> In languages allowing preposition stranding like English, the NP may be extracted alone, leaving the preposition in situ inside the subject or object NP. Example (2.5) illustrates this contrast between subextraction from the subject NP (2.5b) and from the object NP (2.5a). Chomsky’s (1973) introspective judgement is that the former is ungrammatical whereas the latter is grammatical. Most linguists working on this topic agree that the former is at least degraded compared to the latter.

- (2.5) a. (Chomsky 1973: 248)  
Who<sub>i</sub> did you hear [stories about <sub>-i</sub>]?  
b. (Chomsky 1973: 249)  
\* Who<sub>i</sub> did [stories about <sub>-i</sub>] terrify John?

It is traditionally assumed that the very same contrast holds when the whole PP complement is extracted, like in (2.6). We will refer to this kind of extraction as pied-piping extraction, as opposed to preposition stranding extraction like in (2.5). Again, there is agreement in the literature that (2.6b) is at least degraded compared to (2.6a). In Section 7.1, I present studies that have tested this contrast in *wh*-questions.

- (2.6) a. (Chomsky 2008: 147)  
[Of which car]<sub>i</sub> did they find [the driver <sub>-i</sub>]?  
b. (Chomsky 2008: 153)  
\* [Of which car]<sub>i</sub> did [the driver <sub>-i</sub>] cause a scandal?

Still, Chomsky (1986: 32) acknowledges that subextraction from the subject is “more acceptable” with pied-piping, as in (2.7). This observation is barely addressed by minimalists working on subject islands, and Chomsky does not mention it in his subsequent works.

---

<sup>4</sup>In Section 7.1, I present a handful of studies that looked at extraction of the specifier. Here is an example of the material tested by Jurka et al. (2011):

- (i) (Jurka et al. 2011: 125)  
Was<sub>i</sub> hat [<sub>-i</sub> für ein Käfer] denn den Beamten gebissen?  
what has for a beetle indeed the clerk bitten  
‘What kind of beetle bit the clerk?’

## 2.2 The Subject Condition: subextraction from subject NPs

(2.7) (Chomsky 1986: 32)

He is the person [[of whom]<sub>i</sub> [pictures <sub>-i</sub>] are one the table].

In their chapter about the possible location of gap, Huddleston & Pullum (2002: 1093–1094) mention that gaps in a subject NP are only allowed as pied-piping, and give (2.8) as an example.

(2.8) (Huddleston & Pullum 2002: 1093)

They have eight children [[of whom]<sub>i</sub> [five <sub>-i</sub>] are still living at home].

Notice that (2.7) and (2.8) are relative clauses, and not interrogatives like the examples cited before. Chomsky (1986: 32) notes that violations are “less severe” in relative clauses than in interrogatives, “for unclear reasons”.<sup>5</sup> This remark was never addressed again by Chomsky or any syntactic account of subject islands – probably because the violation of the Subject Condition is considered to be present in (2.7), and the effect therefore negligible. I suppose that example (2.7) should be marked as barely acceptable in Chomsky’s view.

Chomsky (1973) assumes that PRO subjects are not available for subextraction, as in (2.9). In this example, *stories about who*, although grammatically the direct object of *expect*, is the underlying subject of *terrify*. It also fills the role of the stimulus of *terrify*, the semantic role associated with the subject for this experiencer-object psych verb. Being an underlying subject, this NP is an island to extraction, according to Chomsky’s analysis.

(2.9) (Chomsky 1973: 249)

\* Who<sub>i</sub> do you expect [stories about <sub>-i</sub>] to terrify John?

Subject-to-object raising verbs (or verbs with Exceptional Case Marking in minimalist terms) should, however, allow extraction out of the raised argument NP (Chomsky 2005: 20; Gallego & Uriagereka 2007; Jiménez-Fernández 2009).

(2.10) (Jiménez-Fernández 2009: 109)

[Of which car]<sub>i</sub> did they believe [the driver <sub>-i</sub>] to have caused a scandal?

---

<sup>5</sup>Chomsky attributes the remarks concerning amelioration through pied-piping and relativization to Kuno (1972), even though I can find no reference to it in that paper.

## 2 Syntactic approaches to the “Subject Condition”

Existential constructions like (2.11a) involve an expletive, a copula and a predicative. The predicative is often treated as a subject in minimalist works.<sup>6</sup> Some scholars (e.g. Stepanov 2007, Uriagereka 2011) assume that subextraction out of this predicative NP is grammatical, cf. (2.11b), but they disagree on why the subject island constraint does not apply in this case.

- (2.11) a. There is [a picture of Grace Kelly] on the wall.  
b. (Stepanov 2007: 102)  
Who<sub>i</sub> is there [a picture of <sub>-i</sub>] on the wall?

The status of the subject of passives is controversial. For some authors, it is more felicitous – or completely acceptable – to extract out of NP subjects of passives than, for example, out of subjects of transitives. Following Chomsky (2008), this is because they are underlying objects and therefore not bound by the subject island constraint.

- (2.12) a. (Kluender 1998: 268)  
? What<sub>i</sub> were [pictures of <sub>-i</sub>] seen around the globe?  
b. (Chomsky 2008: 147)  
It was the CAR (not the TRUCK) [of which]<sub>i</sub> [the driver <sub>-i</sub>] was found.  
c. (Chomsky 2008: 147)  
[Of which car]<sub>i</sub> was [the driver <sub>-i</sub>] awarded a prize?

But others disagree, and hold that extraction out of the subject of a passive is ungrammatical:

- (2.13) a. (Erteschik-Shir 1973: 157)  
\* Who<sub>i</sub> was [a picture of <sub>-i</sub>] painted by Picasso?  
b. (Stepanov 2007: 85)  
?\* Who<sub>i</sub> was [a friend of <sub>-i</sub>] arrested?  
c. (Wexler & Culicover 1980: 325)  
\* It's of success [that]<sub>i</sub> [our hopes <sub>-i</sub>] would be well rewarded].

---

<sup>6</sup>Even though the details of the analyses differ from one scholar to the next, the general idea is that (i) and (2.11a) share the same deep structure:

(i) [A picture of Grace Kelly] is on the wall.

In (i), the subject is base-generated in VP (or vP) and moves to Spec,TP (or Spec,IP). In (2.11a), the subject does not move, and a dummy pronoun occupies Spec,TP (or Spec,IP) in order to fulfil the Extended Projection Principle (the requirement that every verb has a subject).

## 2.2 *The Subject Condition: subextraction from subject NPs*

There is a similar disagreement about acceptability judgments for extraction out of subjects of unaccusatives. These disagreements seem to indicate that the data are borderline as far as acceptability is concerned. In general, syntactic approaches in which subjects are islands to extraction treat extraction out of subjects as ungrammatical (the reason why the sentences are unacceptable). Depending on the particular analysis of “subject islands”, the theory predicts subjects of passives or unaccusatives to fall under the constraint or not (see below). Since the 2010s, there have been several attempts to gather empirical data in order to test the theory’s predictions. I will present some of them in Section 7. But first, I will sketch the different lines of analyses that propose a syntactic reason for the contrast in (2.5).

### 2.2.1 **The start: Chomsky (1973)**

As far as subextraction from the subject is concerned, Chomsky (1973) differentiates between long-distance dependencies and short-distance dependencies. In his proposal, subextraction from the subject in short-distance dependencies like (2.5b) is ruled out by the Subject Condition, whereas subextraction from the subject in long-distance dependencies like (2.9) is ruled out by Subjacency.

The Subject Condition is one of a series of rules on transformations. It is quite straightforward: no XP embedded in a subject may be subextracted from the subject (even though the term “extraction” is not used yet in Chomsky (1973), for the phenomenon is conceived in terms of transformation).

More precisely, the Subject Condition states that there can be no transformational dependency if the element to be transformed – what we will call in this work the “gap position” – is L-contained in a subject. For an XP to be L-contained in a YP, there must be at least one lexical element in YP that is not in XP: this ensures on the one hand that the extraction of a whole NP subject is possible, and at the same time that, for example, the NP-complement of a preposition does not fall under the Subject Condition (for reasons that do not concern me in this work).

The Subject Condition seems ad hoc, because it only accounts for the Subject Island phenomenon and is not based on any independent evidence. It also seems arbitrary, because it is never justified in terms of cognitive processes.

Extraction out of the subject in long-distance dependencies is ruled out by a more general rule based on Subjacency. Here is the definition of Subjacency given by Chomsky:

## 2 Syntactic approaches to the “Subject Condition”

[I]f X is superior to Y in a phrase marker P, then Y is “subjacent” to X if there is at most one cyclic category  $C \neq Y$  such that C contains Y and C does not contain X. (Chomsky 1973: 247)

That X is superior to Y means that it is higher in the syntactic tree: therefore, X is what we will call in this work the filler position, whereas Y is what we will call the gap position. Cyclic nodes are maximal projections in a sentence where syntactic information is processed and passed to PF and LF. For Chomsky (1973), S and NP are the two kinds of cyclic nodes in human language. To paraphrase Chomsky with our terminology, if it is true for more than one of such nodes in the sentence that it contains the gap position but not the filler position, then the gap is not subjacent to its filler.

One of the general rules on transformations states that extraction can only take place if the gap is subjacent to its filler, otherwise the extraction is blocked. Let me illustrate this constraint with the example of subextraction from the subject of an embedded clause we saw in (2.9). The tree in Figure 2.5 gives the underlying (or deep) structure of (2.9), namely (2.14), in which cyclic nodes are circled. Notice that, following the traditional view in Transformation Grammar, the subject is considered to be base-generated outside of VP (Chomsky 1965). In order to form an interrogative, the *wh*-word *who* should occupy the position under the leftmost COMP. There are two cyclic nodes containing the *wh*-word but not the landing site, they are indicated in dashed circles. The NP *who* is therefore not subjacent to the highest COMP, and the transformation is blocked: (2.9) is ruled out.

(2.14) Underlying structure of (2.9):  
you expect stories about who to terrify John

Notice, however, that the transformation would be ruled out for any subextraction from an NP in the embedded clause, so this is not strictly speaking a “subject island” effect (there would be no contrast with subextraction out of an NP object).

In contrast to the Subject Condition, constraints on Subjacency are ultimately explained in terms of cognitive capacities (the cyclic nodes reduce the memory burden). They are also independently motivated, because the same mechanism is used to account for other putative islands, including subextraction from embedded questions. Embedded questions are often called “*wh*-islands”. Ross (1967) was the first to remark that these constructions were special with respect to extraction, but he also noticed that the restrictions were not absolute. For this reason, they belong to the weak islands for scholars who adopt this distinction (e.g. Cinque 1990).



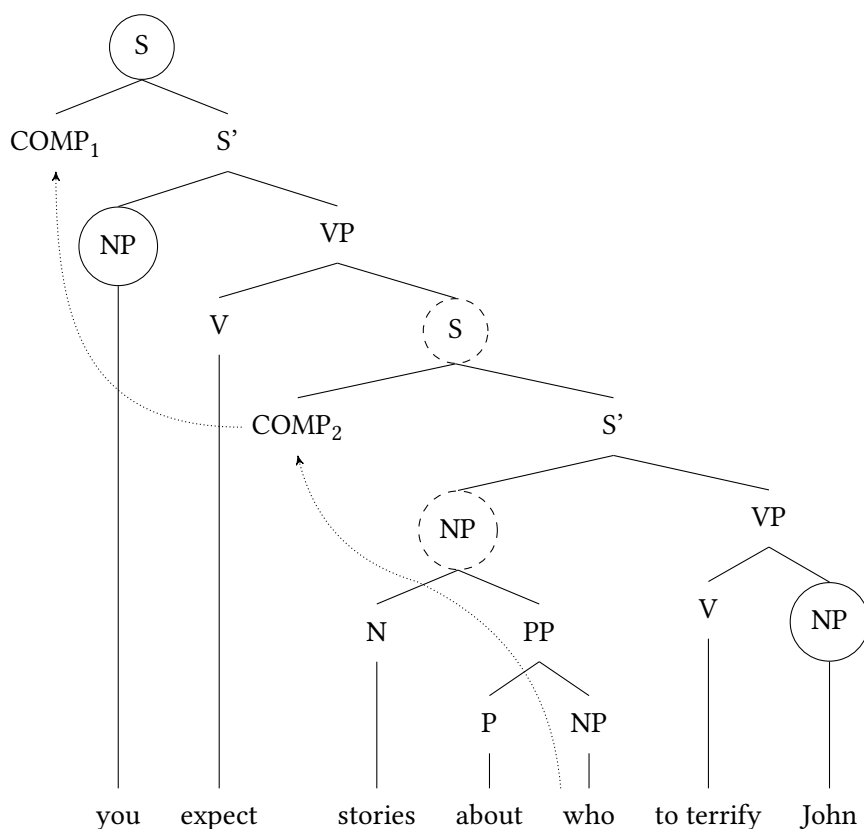

Figure 2.5: Syntactic tree for “you expect stories about who to terrify John” according to Chomsky (1973)

The constraints in Chomsky (1973) are problematic, because they are too restrictive. The so-called *wh*-islands have been shown to have many exceptions, depending on several different factors: the function of the extracted element (extraction of an adjunct is degraded compared to the extraction of an indirect or direct object, see (2.15)), the nature of the filler of the embedded interrogative (Kluender & Kutas 1993b), the finiteness of the embedded question, and the specificity of the extracted element or of the *wh*-filler of the embedded question (Kluender 1998).<sup>7</sup> And yet, all extractions out of an embedded question should be excluded by Subjacency to the same degree.

<sup>7</sup>For a discussion of French data and the difference in acceptability between extraction of an adjunct, an indirect object or a direct object on the one hand, and extraction out of *wh*-embedded questions and *si*-embedded questions (similar to English *if*-embedded questions) on the other hand, see Hirschbühler & Valois (1992).

## 2 Syntactic approaches to the “Subject Condition”

- (2.15) a. (Cinque 1990: 1)  
\* How<sub>i</sub> did they ask you [who<sub>j</sub> <sub>-j</sub> behaved <sub>-i</sub>]?  
b. (Cinque 1990: 1)  
[To whom]<sub>i</sub> didn't they know [when to give their present <sub>-i</sub>]?  
c. (Szabolcsi 2006: 494)  
[Which problem]<sub>i</sub> did John ask [how to phrase <sub>-i</sub>]?

Subjacency also rules out subextraction out of a dependent of the dependent of a noun like (2.16).

- (2.16) (Chomsky 1973: 248)  
\* What<sub>i</sub> do you receive [requests for [articles about <sub>-i</sub>]]?

This is problematic, because felicitous cases of such structures are very easy to find. Ross (1967) cites example (2.17a) for English. I was also able to find many such examples for French in the corpus frWaC (Baroni et al. 2009). Example (2.17b) is one of them.

- (2.17) a. (Ross 1967: 15)  
[What books]<sub>i</sub> does the government prescribe [the height of [the lettering of <sub>-i</sub>]]?  
b. Il présente cependant les défauts traditionnels des textes  
it has however the flaws traditional of the texts  
internationaux [dont<sub>i</sub> [la réalité de [l' application <sub>-i</sub>]] est  
international of which the reality of the application is  
très rarement contrôlée].  
very rarely controlled  
'It has the traditional flaws of international texts, the reality of the application of which is rarely controlled.'

Since Chomsky (1973), there have been a vast number of syntactic approaches to the subject island constraint. In my view, they can be divided into three principal groups, which I will now present briefly.

### 2.2.2 The subject is a non-complement: The CED and its successors

#### 2.2.2.1 The Condition on Extraction Domain

Huang (1982) introduces another island into the list proposed by Ross (1967): the adjunct island. For him, the ban on extraction out of adjuncts like (2.18) is parallel to the ban on extraction out of subjects.

## 2.2 The Subject Condition: subextraction from subject NPs

(2.18) \* Who<sub>i</sub> did Mary cry [after John hit <sub>-i</sub>]?

He considers the Subject Condition to be only “a special case of an even more general asymmetry between complements on the one hand and non-complements (subjects and adjuncts) on the other” (Huang 1982: 503). He subsumes Chomsky’s (1973) Subject Condition with Kayne’s (1981) Empty Category Principle in a constraint called the “Condition on Extraction Domain”, which is reproduced in (2.19).

(2.19) Condition on Extraction Domain (Huang 1982: 505)

A phrase A may be extracted out of a domain B only if B is properly governed.

Since objects are complements of V, they are c-commanded by a lexical head, and thus “properly governed”. For this reason, extraction out of NP objects or sentential complements is possible. Subjects and adjuncts are not c-commanded by V, therefore subextraction out of subjects and adjuncts is blocked, following Huang.

Huang’s (1982) CED inspired a lot of subsequent work on subject islands, and started the tradition of considering the Subject Island and the adjunct island under the same constraint. An important successor of Huang’s (1982) CED is the concept of “Barriers” in Chomsky (1986).

### 2.2.2.2 Barriers

In the 80’s, Chomsky model of sentence construction had changed compared to Chomsky (1973). During this period, the operation *MOVE* had been introduced. In Chomsky (1986), he assumes that a moved element leaves a trace (*t*) at the position it occupies at deep structure, and at any position occupied during movement. The movement of *wh*-words (*wh*-movement) is cyclic, and the landing site of each cyclic movement must be a specifier position. Notice also that the subject is considered to be base-generated in Spec,IP (this view has been abandoned since, see below). The tree in Figure 2.6 illustrates how (felicitous) movement works in Chomsky’s (1986) account: *who* first moves from its initial position to the specifier position of VP and from that position to the specifier position of CP (notice that the specifier of IP is not available for movement, Chomsky 1986: 32). There is also a second movement involved here: head-movement of *did* from I to C, but this is not *wh*-movement.

(2.20) Who did you hear stories about? [see (2.5a)]

2 Syntactic approaches to the “Subject Condition”

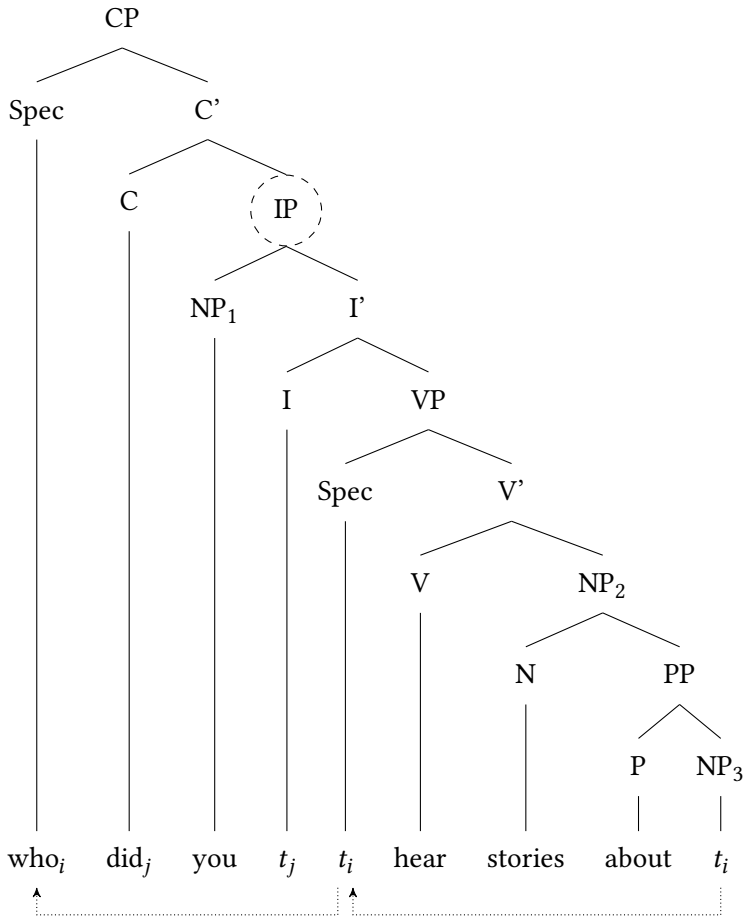

Figure 2.6: Syntactic tree for “Who did you hear stories about?” according to Chomsky (1986)

“Cyclic categories” of Chomsky (1973) have now been replaced by “blocking categories” and “barriers”. Any maximal projection which is not directly assigned a  $\theta$ -role by a lexical category is a blocking category for any element it contains. A blocking category becomes a barrier for movement<sup>8</sup> under certain conditions given in 2.21.

- (2.21)  $\gamma$  is a barrier for  $\beta$  iff (a) or (b):  
 (a)  $\gamma$  immediately dominates  $\delta$ ,  $\delta$  a [blocking category] for  $\beta$   
 (b)  $\gamma$  is a [blocking category] for  $\beta$ ,  $\gamma \neq \text{IP}$

<sup>8</sup>Other rules apply to block other kinds of government that we will not discuss here.

## 2.2 The Subject Condition: subextraction from subject NPs

Subjacency receives a new definition based on the concept of barriers as defined in (2.21): an element is 0-subjacent to a (dominating) landing site if there is no barrier between them; it is 1-subjacent if there is one barrier crossed, 2-subjacent if there are two barriers, etc.

Let us illustrate subject islands as explained by subjacency by comparing (2.20) whose analysis is shown in Figure 2.6 and (2.22) whose analysis is shown in Figure 2.7. Blocking categories are circled; we used a plain line for those that are barriers, and a dashed line for those that are not.

(2.22) Who did stories about terrified John? [see (2.5b)]

In Figure 2.6, NP<sub>2</sub> is directly assigned a  $\theta$ -role by V and thus not a blocking category; the VP is per definition lexical and thus not a blocking category; and the IP, even though it is a blocking category, is not a barrier because of (2.21b). The initial position of *who* is hence 0-subjacent to its landing position.

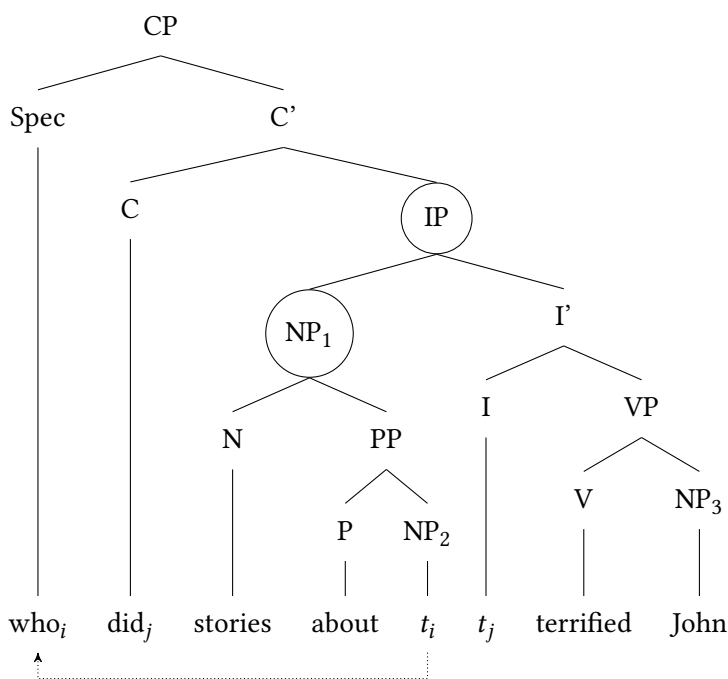

Figure 2.7: Syntactic tree for "Who did stories about terrified John?" according to Chomsky (1986)

The tree in Figure 2.7, on the other hand, illustrates what happens when extracting out of a subject. The PP is directly assigned a  $\theta$ -role by N and is therefore not a blocking category. But NP<sub>1</sub>, being base-generated outside of VP, is not

## 2 Syntactic approaches to the “Subject Condition”

directly assigned a  $\theta$ -role<sup>9</sup> and is a blocking category and a barrier because of (2.21b). Furthermore, the IP is a blocking category, and also a barrier because of (2.21a). The initial position of *who* is hence 2-subjacent to its landing position.

The link between subjacency and acceptability is explicitly stated: the more subjacent the trace is relative to its landing position, the less acceptable the sentence. Thus Chomsky (1986) introduces a notion of gradient acceptability in his theory, although the distinction used to be categorial. In general, if we follow acceptability judgments in his work, it seems that 0-subjacent dependencies are acceptable, 1-subjacent dependencies are awkward (?) and 2-subjacent dependencies ungrammatical or unacceptable (\*).

Stepanov (2007: 82) criticizes the theory of barriers, because “ $\theta$ -theory and bounding theory (responsible for the locality of movement including extraction) are different modules of core grammar, driven by separate sets of principles”.

Deane (1991), on the other hand, noticed that the definition of Barriers, like Subjacency in Chomsky (1973), is too strong. It excludes acceptable examples like (2.23), in which the relative word crosses one IP and two NPs. Example (2.23) is reminiscent of example (2.17a) cited before.

(2.23) (Deane 1991: 10)

Nixon was one president that<sub>i</sub> [they had no trouble getting [votes for [the impeachment of <sub>-i</sub>]<sub>DP</sub>]<sub>DP</sub>]<sub>IP</sub>.

For French, counterexamples similar to (2.23) have been produced by Godard (1988). Yet none of them is subextraction from a subject or an adjunct.

(2.24) a. (Godard 1988: 38)

La pièce; que<sub>i</sub> [l' évolution de la situation politique donnait  
the play that the evolution of the situation political gave  
[l' impression [qu' on pouvait enfin monter <sub>-i</sub>]<sub>IP</sub>]<sub>NP</sub> n' a  
the impression that one could finally create NEG has  
pourtant pas été autorisée.  
yet not been allowed  
'The play that the political development gave the impression that  
it would be finally possible to create (it) has yet not been allowed.'

---

<sup>9</sup>Subjects are only indirectly  $\theta$ -marked (cf. Chomsky 1986: 13), because they receive their  $\theta$ -marking from the VP and not from the head V (Chomsky 1981: 37). Only lexical words can L-mark their arguments, phrases cannot.

## 2.2 The Subject Condition: subextraction from subject NPs

- b. (Godard 1988: 59)
- un problème<sub>i</sub> auquel<sub>i</sub> il me semble [qu' on m' a  
a problem at.which it 1.SG.DAT seems that one 1.SG.ACC has  
dit [que tu t' étais attaqué <sub>-i</sub>]IP]IP  
told that you REFL were tackle  
'a problem that I believe that someone told me that you tackled'

### 2.2.3 The subject is a specifier: The Connectedness Condition and other “specifier”-based analyses

#### 2.2.3.1 The Connectedness Condition

In contrast to Chomsky and Huang, Kayne (1983) does not assume that the subject island constraint holds in all languages. Indeed, as already noticed by Ross (1967), Japanese seems to allow extraction out of subjects. Instead of treating the constraint as language-specific, as Ross did, Kayne proposes that it is a consequence of the canonical government configuration which differs between English and French on the one hand and Japanese on the other hand. In English and French, which are SVO languages, the verb canonically governs its complement on the right, while in Japanese, which is an SOV language, the verb canonically governs its complement on the left.

Following Kayne (1983: 225), an extracted element must be inside an XP that is canonically governed by the verb. In Japanese, the subject is on the left of the V, therefore it is canonically governed, and subextraction out of the subject is possible. In English and French, the subject is on the left of the V, and is therefore not canonically governed, so subextraction out of the subject is banned.

With this rule, Kayne (1983) does not only account for the subject island, but also for the Left Branch Condition in Ross (1967: 207–217), which stated that no leftmost element of an NP may be extracted out of the NP.

(2.25) (Ross 1967: 208)

- a. We elected [the boy's guardian's employer]<sub>NP</sub> president.  
b. \* The boy [[whose guardian's]<sub>i</sub> we elected [<sub>-i</sub> employer] president] ratted on us.  
c. \* The boy [whose<sub>i</sub> we elected [<sub>-i</sub> guardian's employer] president] ratted on us.

Indeed, elements in the specifier position of NPs are not canonically governed following the Connectedness Condition.

## 2 Syntactic approaches to the “Subject Condition”

Longobardi (1985) takes over Kayne’s (1983) Connectedness Condition and applies it to adjunct islands. It is relatively straightforward that extraction out of an AdvP that is situated on the left of V is ruled out by the Connectedness Condition. But even AdvP on the right of the verb are analyzed by Longobardi (1985) as being sisters to the VP, and thus not c-commanded by the verb (see ex. 14 in Longobardi 1984: 157). Subextraction would then be ruled out.

### 2.2.3.2 Phase Impenetrability

To understand phrase impenetrability, we have to start with Chomsky’s (2001) decision to make the notion of “phases” a core concept of his analysis. This new turn is known as the Phase Theory. Phases are comparable to barriers. I will summarize here the analysis in Chomsky (2008), but, even though the theory has evolved since 2001, the general idea of the phase impenetrability has remained unchanged.

Some maximal projections, namely  $v^*P$  and CP, are phases. Sentence formation proceeds in a bottom-up fashion, thus the lower phases are formed before the higher ones, one at a time. At the Edge of a given phase, the information inside this maximal projection is transferred to the phonetic and semantic interface. After the transfer, the phase remains impenetrable for heads higher in the tree, and no element can move out of the phase. The only way an element can undergo movement higher in the syntactic tree is by moving to the Edge of the maximal projection prior to the Transfer.<sup>10</sup> Figure 2.8 illustrates a simple extraction out of the object following the Phase Theory. Phases are identified with circles.<sup>11</sup>

Since Chomsky (1995), following a proposal by Kitagawa (1986) and Koopman & Sportiche (1991), Chomsky assumes that (some) subjects are base-generated in the specifier position of the functional projection  $vP$  (or  $v^*P$ ). No movement is allowed from a specifier to the Edge of the same maximal projection. That is

---

<sup>10</sup>Chomsky (2008), to my knowledge, never explicitly describes what the Edge is. In the following, I assume that the Edge is a sister to the XP (or X’) situated on its left, some sort of second specifier above the specifier.

<sup>11</sup>It is generally assumed that at least the agentive subjects are base-generated under Spec, $vP$  (or VoiceP, which is roughly similar to  $vP$ ). For example, Kratzer (1996) proposes that there are two different VoicePs, one for licensing agentive subjects and one for licensing holder subjects, and Alexiadou et al. (2015: Chapter 2) distinguish three different VoicePs, so that causer subjects are also external arguments. This implies that some subjects, such as experiencer subjects, would be internal arguments. Does this mean that these analyses do not predict an island effect for non-agentive/non-holder/non-causative subjects? As far as I know, this question has not been addressed by these authors. In any case, the answer has no bearing on the interpretation of the empirical data that I present in Part II. I will argue this point in Section 14.4.2.2, in which I briefly return to the issue of experiencer subjects.



## 2.2 The Subject Condition: subextraction from subject NPs

why extraction out of these subjects is not allowed: as illustrated in Figure 2.9, the complement of the subject noun cannot move to the Edge of the v\*P, and is therefore transferred to the phonetic and semantic interfaces where it is no longer accessible for C. Hence the subextraction is ungrammatical.

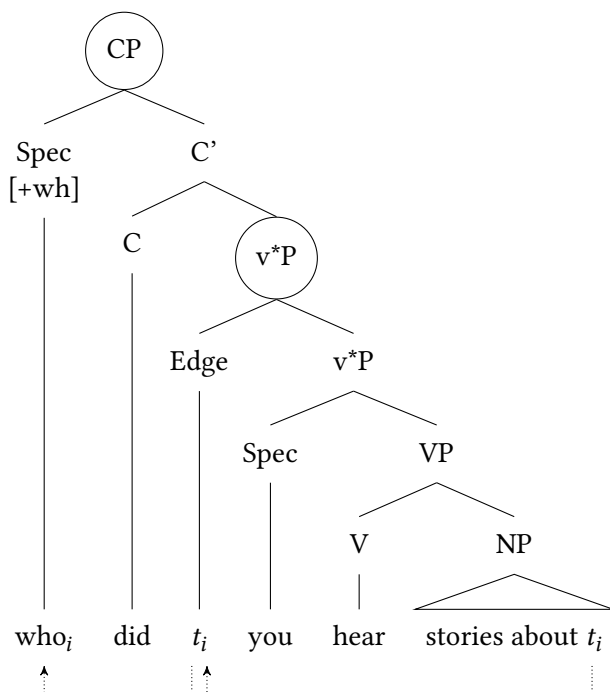

Figure 2.8: Syntactic tree for “Who<sub>i</sub> did you hear [stories about <sub>-i</sub>]?” according to Chomsky (2008)

The verbal projection v\*P is only projected for verbs that require an external argument, such as transitive verbs. When subjects are internal arguments (underlying objects), there is no v\*P, and therefore no phase. That is why subextraction out of the subject of passives, like (2.26), is acceptable. The analysis is shown in Figure 2.10 on page 39. For the same reason, extraction out of subjects or unaccusatives is predicted to be grammatical.<sup>12</sup>

<sup>12</sup>This prediction of Phase Theory is not addressed by Chomsky, but has been underlined by Polinsky et al. (2013) and Haegeman et al. (2014). Perlmutter (1978) proposed a distinction between unaccusative and unergative verbs, based on their distinct syntactic behavior that correlates with distinct semantic properties. This hypothesis has been formalized in the GB framework by Burzio (1986). In his approach, at deep structure, unergative verbs take an external argument (subject) and no internal argument, while unaccusative verbs take an internal

## 2 Syntactic approaches to the “Subject Condition”

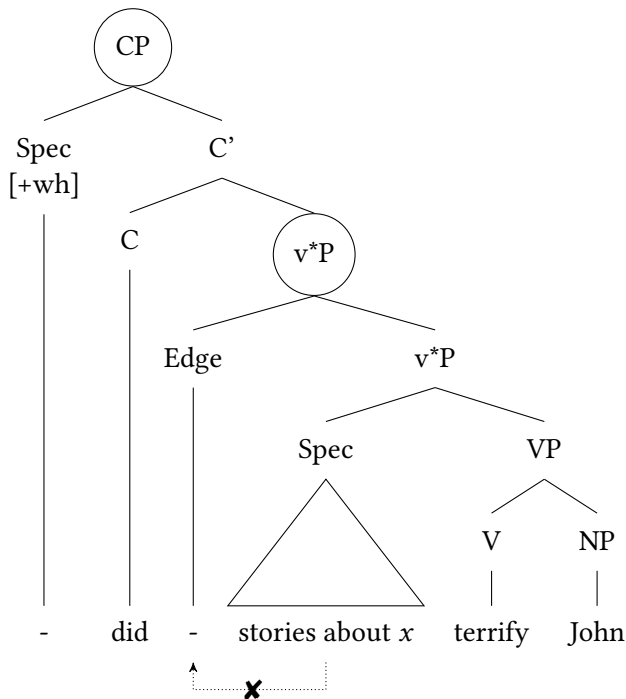

Figure 2.9: Syntactic tree for “Who<sub>i</sub> did [stories about -<sub>i</sub>] terrify John?” according to Chomsky (2008)

(2.26) Who<sub>i</sub> were [stories about -<sub>i</sub>] written down?

### 2.2.3.3 Spell out

The analysis of Spell out developed in Nunes & Uriagereka (2000) and Uriagereka (2011) (a.o.) borrows some elements from Phase Theory, while taking into account the incremental processing of sentences. I will summarize here the analysis in Uriagereka (2011), which incorporates many of the elements developed in previous work by Uriagereka and his colleagues. The starting point of this analysis is the Linear Correspondence Theorem (LCT), which states, in a nutshell,

---

argument (object) and no external argument. With both kinds of verbs, at the surface, the argument appears outside of VP, in the subject position. The consequence for Phase Theory, as Polinsky et al. notice, is that extraction out of subjects of unergatives should be ungrammatical, whereas extraction out of subjects of unaccusatives should be grammatical. They conducted an experiment to test this prediction, see Section 7.

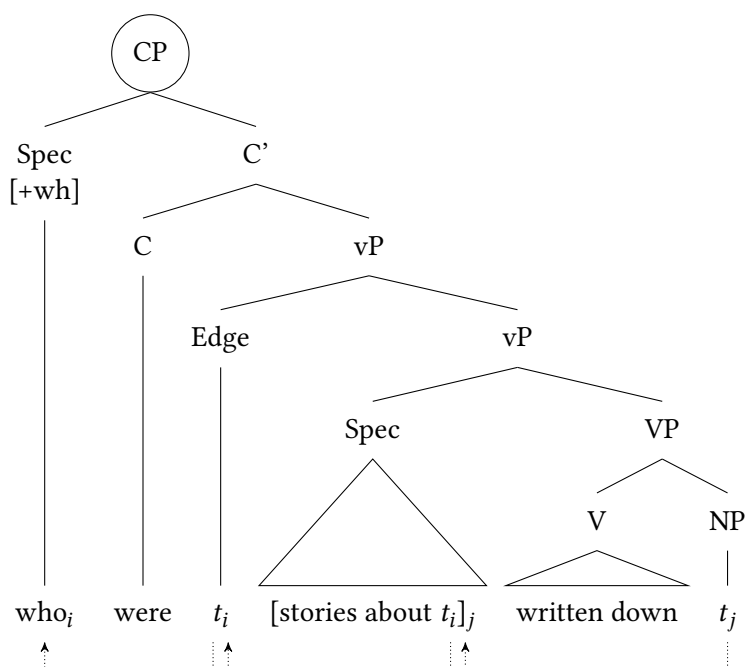

Figure 2.10: Syntactic tree for “Who<sub>i</sub> were [stories about  $t_i$ ] written down?” according to Chomsky (2008)

that asymmetrical branching (i.e. a pair of branches with one terminal node and one non-terminal node) (Uriagereka 2011: 53) and a configuration in which the terminal node precedes the non-terminal one (Uriagereka 2011: 56) is easier to parse than other combinations.<sup>13</sup> This is illustrated by Figure 2.11 on page 40: the tree in (b) first branches into two non-terminal nodes and thus violates the first part of the LCT (Finite State Limit); in the tree in (c), the non-terminal nodes precede the terminal ones, which violates the second part of the LCT (Linear Correspondence Axiom).

Whenever we have to parse a syntactic structure that does not follow the LCT, the tree is chunked into different sub-trees that are in accordance with the LCT and are then parsed in parallel. A sentence with a complex subject is similar to the tree (b) in Figure 2.11. The NP subject is then parsed as a unit: this is the operation called *Spell out*. After *Spell out*, the structure is no longer phrasal, but it is treated as a word. The mechanism is illustrated by Figure 2.12. The internal structure of the subject is hardly accessible, because of *Spell out*.

<sup>13</sup>The Binary Principle (Culicover & Wexler 1977) was a very similar idea.

## 2 Syntactic approaches to the “Subject Condition”

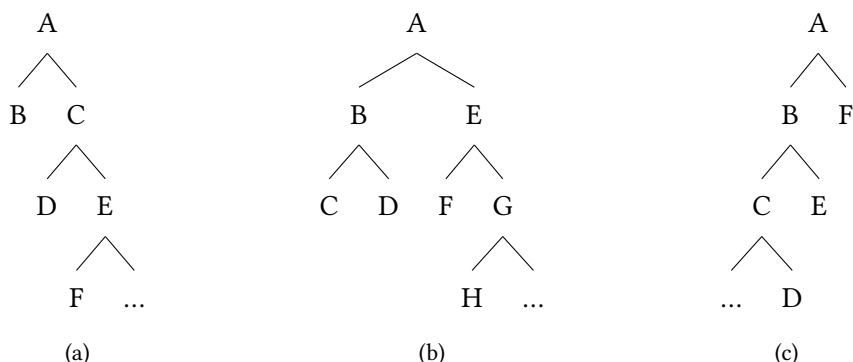

Figure 2.11: Illustration of the Linear Correspondence Theorem; Tree (a) is in accordance with the Linear Correspondence Theorem; Tree (b) violates the Finite State Limit; Tree (c) violates the Linear Correspondence Axiom

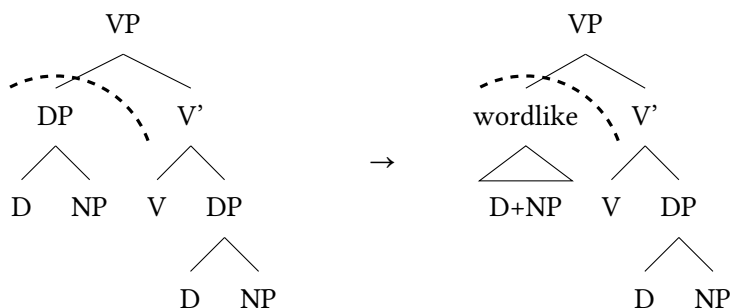

Figure 2.12: Spell out for a sentence with a complex subject

Subextracting out of the subject implies that the subject is complex, and thus subextraction is made very difficult by Spell out. The same applies to adjuncts, which are considered to modify maximal projections: the VP and the adjunct XP are built in parallel.

Ultimately, in Uriagereka’s (2011) account, the cause of the subject island constraint is the fact that the subject is in a specifier position, but for reasons different from the proposal of Kayne (1983) or of Chomsky (2008). Also, unlike these previous analyses, the subject is not completely opaque for subextraction. It is merely hard to interpret, because “any extraction from there [the subject] will involve material within something that is not a syntactic object” (Uriagereka 2011: 92–93). Furthermore, subextraction out of some subjects may face an additional difficulty which I explore further in the next section.

### 2.2.4 The subject is moved: Freezing analyses

A historical overview of the analysis of Freezing effects can be found in Corver (2006). He finds the origin of these analyses in Ross's (1967) constraint on extraposition and Heavy NP shift: no subextraction can take place out of an element that has moved to the right. I present here three influential approaches that attribute the difficulty to extract out of a subject to the fact that the subjects typically move to Spec,IP, a view commonly adopted in Minimalism (see above).

#### 2.2.4.1 The Freezing Principle

The Freezing Principle was originally formalized in Wexler & Culicover (1980). The part of the Freezing Principle that is relevant for our topic is the Raising Principle, reproduced in (2.27).

- (2.27) If a node A is raised, then no node that A dominates may be used to fit a transformation.<sup>14</sup> (Wexler & Culicover 1980: 341)

Wexler & Culicover used the Raising Principle to account for a ban on extraction out of extraposed elements like (2.28b).<sup>15</sup>

- (2.28) (Wexler & Culicover 1980: 341–342)
- a. [A suspicion  $-_i$ ] has arisen [that you have been holding back on the IRS] $_j$ .
  - b. \* The IRS is the government agency [[that] $_j$  [a suspicion  $-_i$ ] has arisen [that you are holding back on  $-_j$ ] $_i$ ].

Based on some evidence from German and Dutch, Müller (1998) proposed to generalize the Freezing Principle to any kind of movement. For example, in German, extraction out of an element that has scrambled rightward from its canonical position in the middlefield is degraded compared to the same subextraction from the canonical position. Compare extraction out of the scrambled object NP in (2.29a) with extraction out of the object NP in situ in (2.29b).

---

<sup>14</sup>Or, in other words: "If a node has been raised, it is frozen; that is, further transformations may not analyze nodes below the raised node." (Wexler & Culicover 1980: 28).

<sup>15</sup>The extraposed sentential complement in (2.28b) is "raised" because Wexler & Culicover (1980) define raising as movement from inside a cyclic category (NP or S) to inside another cyclic category higher in the syntactic tree. In (2.28a), the cyclic category of the sentential complement is the subject NP. In (2.28b), Wexler & Culicover (1980) assume that the sentential complement has moved to a position sister to V; its cyclic category is hence the matrix S, which is higher in the tree.

## 2 Syntactic approaches to the “Subject Condition”

(2.29) (Müller 1998: 20)

- a. \*Worüber<sub>i</sub> hat [ein Buch –<sub>i</sub>]<sub>j</sub> keiner –<sub>j</sub> gelesen?  
about.what has a book nobody read
- b. Worüber<sub>i</sub> hat keiner [ein Buch –<sub>i</sub>] gelesen?  
about.what has nobody a book read  
‘About what did nobody read a book?’

Gallego & Uriagereka (2007) discuss what they consider to be a similar contrast in English:

(2.30) a. (Stepanov 2007: 80)

?\* Who<sub>i</sub> does [a picture of –<sub>i</sub>] hang on the wall?

b. (Stepanov 2007: 102)

Who<sub>i</sub> is there [a picture of –<sub>i</sub>] on the wall?

According to them, in (2.30a), the NP *a picture of who* first undergoes movement to Spec,TP, and for this reason the subsequent movement from *who* from Spec,TP to Spec,CP is ruled out. By contrast, the subject NP *a picture of who* in (2.30b) does not move to Spec,TP. Instead, Spec,TP is occupied by *there* in order to fulfil the EPP requirement, and movement of *who* to Spec,CP is felicitous.

Boeckx (2003: 103) explains Freezing by the principle of feature checking. Movement is triggered by the need of an element to check its features: the subject moves because of the Case-feature. Once an element has checked its features, it becomes “inert”. For this reason, agreement and extraction are no longer possible.

Notice however that Müller (1998) still assumes Subjacency, because he considers extraction out of in-situ subjects to be ungrammatical:

(2.31) (Müller 1998: 30)

- \* [Über wen]<sub>i</sub> hat [ein Buch –<sub>i</sub>] den Karl beeindruckt?  
about who has a book the.ACC Karl impressed  
‘About whom did a book impress Karl?’

In example (2.31), the subject was not scrambled, so Freezing cannot be the reason for the ungrammaticality.<sup>16</sup> Gallego & Uriagereka’s (2007) explanation

---

<sup>16</sup>According to Müller (1998), subjects of passives are underlying objects and do not need to move to a subject position in German. Extraction out of them is felicitous:

(i) (Müller 1998: 124)

- Worüber<sub>i</sub> ist von keinem [ein Buch –<sub>i</sub>] gelesen worden?  
about.what AUX by nobody a book read been  
‘About what was a book read by nobody?’

Such subjects are not frozen as they are internal arguments.

for the grammaticality of (2.30b) is therefore not compatible with Müller's (1998) analysis.

#### 2.2.4.2 Chain Uniformity

Takahashi (1994) defines two main constraints on movement, which are reproduced in (2.32).

- (2.32) a. Shortest Movement Condition (SMC): Make the Shortest Movement. (Takahashi 1994: 8)
- b. Uniformity Corollary on Adjunction (UCA): Adjunction is impossible to a proper subpart of a uniform group where a uniform group is a nontrivial chain or a coordination. (Takahashi 1994: 25)

Let me add some explanation in order to better understand the constraints in (2.32). In his definition of SMC, Takahashi assumes cyclic movement, in which the extracted element is copied into the nearest appropriate position, then into the next one, and so on until the final position. Lower copies of an element are deleted at surface structure. *Wh*-movement is seen as movement to a specifier position (cyclically from specifier to specifier). Furthermore, *wh*-movement (extraction) is analyzed as adjunction rather than substitution, and a nontrivial chain means that the element has a copy, hence that it has moved. This is what makes the UCA ultimately similar to Freezing, except that it also accounts for the Coordinate Structure Constraint.

In order to extract out of a subject that has moved from Spec,VP to Spec,IP<sup>17</sup>, there are two options: (i) the closest specifier position is Spec,DP of the subject DP – but this is disallowed by the UCA – or (ii) the copy is adjoined to Spec,IP, which violates the SMC. Hence, it is not possible to have fully acceptable subextraction from a subject.

Uriagereka (2011) combines the constraints on Spell out (see above) with Takahashi's (1994) SMC and UCA in order to account for subject island effects. Recall that the effects of Spell out are not seen as categorical: extracting out of a complex NP in specifier position makes parsing more complicated, but not impossible. Shortest Move is also considered by Uriagereka as a preference, rather than a rule. According to him, this explains a contrast found in Spanish in extraction out of preverbal vs. postverbal subjects.

---

<sup>17</sup>Takahashi assumes this movement for English and French subjects (Takahashi 1994: 28), but not for Japanese subjects (Takahashi 1994: 65), hence the acceptability of extracting out of the subject in Japanese, see below.

## 2 Syntactic approaches to the “Subject Condition”

- (2.33) a. ?? [De qué artistas]<sub>i</sub> han herido tu sensibilidad [las  
of what artists have.3PL hurt your sensibility the  
obras <sub>-i</sub>]?  
works
- b. \* [De qué artistas]<sub>i</sub> [las obras <sub>-i</sub>] han herido tu  
of what artists the works have.3PL hurt your  
sensibilidad?  
sensibility

In both (2.33a) and (2.33b), the subject is in a specifier position, and the subextraction is degraded because of Spell out. But in (2.33a), the subject is in situ in Spec,VP, while in (2.33b), the subject has moved from Spec,VP to Spec,TP. The subextraction in (2.33b) hence violates two principles, thus it is degraded compared to (2.33a), which only violates one principle. As the reader can see, Uriagereka (2011) and Müller (1998) have very similar views, even though the details of their analyses differ.

### 2.3 The subject island constraint cross-linguistically

Ross himself asserted that the Sentential Subject Constraint in (2.1) only applies in some languages.

This constraint [i.e. (2.1)], though operative in the grammars of many languages other than English, cannot be stated as a universal, because there are languages whose rules are not subject to it. (Ross 1967: 243)

But subsequent accounts based on syntax explicitly or implicitly assume that the constraints that cause subject island effects are universal. Of course, many counterexamples have been brought up and discussed over the years. That is one of the reasons why the syntax-based analyses became more and more sophisticated, taking advantage of cross-linguistic properties that would explain why some languages can “escape” the subject island constraint.

#### 2.3.1 The discussion around French

Most of the discussion on extraction out of NPs in French addresses the extraction of a specific kind of French complement: *de*-phrases (or *de*-PPs). These PPs are introduced by the preposition *de* (‘of’) and can express almost any kind of relation between the NP inside the PP and the N head. For example, the most



### 2.3 The subject island constraint cross-linguistically

direct reading for (2.34a) is one with the *de*-phrase expressing possession, but it could also be a less unspecific and more context-dependent relation (for example, the house Thérèse always talks about). Part-whole relations for body parts like (2.34b) are also possible, etc.

- (2.34) a. la maison de Thérèse  
the house of Thérèse
- b. la main d' Adrien  
the hand of Adrien

These *de*-PPs are not only used as complements of nouns, but also as complements verbs, adjectives, etc. All *de*-PPs can be extracted with *dont* ('of which'), *de qui* ('of who'), *de quoi* ('of what'), *duquel* ('of which' [+masculine,+sg]), *desquels* ('of which' [+masculine,+pl]), *de laquelle* ('of which' [+feminine,+sg]), *desquelles* ('of which' [+feminine,+pl]) or *de quel(le)(s) + N* ('of which +N').

The French relative word *dont* is used exclusively to introduce relative clauses with an antecedent or *c'est*-clefts, see examples (2.35a), (2.35b), (2.35c) and (2.35d). It cannot be in situ and may not be the complement of a preposition: it therefore does not allow pied-piping, as illustrated in (2.35e) where *loin* ('far') is a French preposition.

- (2.35) a. cet homme [*dont*<sub>i</sub> on m' a dit du bien <sub>-i</sub>]  
this man of.which one me.ACC has told some good  
intended: 'this man who I heard good things about'
- b. \*Je me souviens [*dont*<sub>i</sub> on m' a dit du bien <sub>-i</sub>].  
I myself remember of.which one me.ACC has told some good  
intended: 'I remember who(ever) I heard good things about.'
- c. \**Dont*<sub>i</sub> as - tu dis du bien <sub>-i</sub>?  
of.which have you told some good  
intended: 'About who did you say good things?'
- d. C' est cet homme [*dont*<sub>i</sub> on m' a dit du bien <sub>-i</sub>].  
it is this man of.which one me.ACC has told some good  
intended: 'It's this man who I heard good things about'
- e. \*cet homme [[*loin dont*]<sub>i</sub> je suis <sub>-i</sub>]  
this man far of.which I am  
intended: 'the man who I am far from'

In some circumstances, the relative word *dont* is linked to to a resumptive pronoun rather than a gap (Godard 1988, Abeillé & Godard 2007). In this work, we

## 2 Syntactic approaches to the “Subject Condition”

will concentrate on *dont* relative clauses containing a gap. In these cases, *dont* must occur with a *de*-PP gap. In example (2.36), the verb *assister* (‘to attend’) requires a PP complement introduced by *à*, and *dont* cannot be used for the extraction.

- (2.36) a. Jeannine assiste à une conférence.  
Jeannine attends at a conference  
‘Jeannine attends a conference.’
- b. \*la conférence [*dont*<sub>i</sub> Jeannine assiste <sub>-i</sub>]  
the conference of.which Jeannine attends  
intended: ‘the conference that Jeannine attends’

In this usage, *dont* can roughly be translated as ‘of which’ (‘of whom’ with human antecedents), and will systematically be glossed of .which. But *dont* also can be used in verbless partitive relative clauses like (2.37), where it means something like ‘among which’.<sup>18</sup> In these cases, *dont* is not linked to a gap.

- (2.37) Pierre a plusieurs passions, dont le ski.  
Pierre has several hobbies of.which the skiing  
‘Pierre has many hobbies, among which skiing.’

The combination *de* (‘of’) + *qui* (‘who’) is also available to extract a *de*-PP, provided that the head noun is animate.

- (2.38) a. l’ homme [[*de qui*]<sub>i</sub> / *dont*<sub>i</sub> il parle <sub>-i</sub>]  
the man of who of.which he talks  
‘the man he talks about’
- b. l’ ordinateur [[\**de qui*]<sub>i</sub> / *dont*<sub>i</sub> il parle <sub>-i</sub>]  
the computer of who of.which he talks  
‘the computer he talks about’

Apart from that, it is less restricted than *dont*: it can be used in relative clauses with an antecedent like (2.39a) or free relative clauses (like 2.39b), but also in interrogatives like (2.39c), *c’est*-clefts like (2.39d) or exclamatives. It may also serve as complement to a preposition and thus appears in pied-piping constructions, as (2.39e) illustrates.

---

<sup>18</sup>See Bilbiie & Laurens (2010) for a detailed description of these verbless partitive relative clauses.

### 2.3 The subject island constraint cross-linguistically

- (2.39) a. cet homme [[de qui]<sub>i</sub> on m' a dit du bien <sub>-i</sub>]  
 this man of who one me.ACC has told some good  
 'this man who I heard good things about'
- b. Je me souviens [[de qui]<sub>i</sub> on m' a dit du bien <sub>-i</sub>].  
 I myself remember of who one me.ACC has told some good  
 'I remember who(ever) I heard good things about.'
- c. [De qui]<sub>i</sub> as - tu dis du bien <sub>-i</sub>?  
 of who have you told some good  
 'About whom did you say good things?'
- d. C' est cet homme [[de qui]<sub>i</sub> on m' a dit du bien <sub>-i</sub>].  
 it is this man of who one me.ACC has told some good  
 'It's this man who I heard good things about.'
- e. cet homme [[loin de qui]<sub>i</sub> je suis <sub>-i</sub>]  
 this man far of who I am  
 'the man who I am far from'

Following a proposal by Godard (1988), there is general consensus that French *dont* is a complementizer, as are *que* and the subject-subordinate variant of *qui*<sup>19</sup>, whereas the other fillers used in relative clauses, including *de qui*, are pronouns (Tellier 1990, Abeillé & Godard 2007, Le Goffic 2007). The distinction between relative pronouns and complementizers relies on four main contrasts. First, complementizers are invariable, whereas most relative pronouns have to agree with their antecedent in gender and number. Second, relative pronouns may semantically constrain their antecedent (like *de qui*, which does not allow for inanimate antecedents), whereas complementizers do not. Third, complementizers cannot be used in pied-piping constructions (as stated before, *dont* cannot but *de qui* can). Finally, relative pronouns may introduce an infinite relative clause, but complementizers require a tensed verb: this is only marginally true for *dont*, which allows infinitivals to some extent.

- (2.40) a. ? une personne [dont dire du bien]  
 a person of.which tell.INF some good
- b. une personne [de qui dire du bien]  
 a person of who tell.INF some good  
 'a person one can speak well about'

<sup>19</sup>In French, Abeillé & Godard (2007) assume two lexical entries for *qui* ('who'): one is a complementizer and is used only in subordinate clauses when followed by a subject gap, the other is a pronoun and is used in all other cases.

## 2 Syntactic approaches to the “Subject Condition”

- c. \* un restaurant [qu’ apprécier]  
a restaurant that appreciate.INF  
‘a restaurant one can appreciate’

Godard (1988) cited several examples with relativization out of the subject using *dont* such as those in (2.41), challenging the general tradition on subject islands.

- (2.41) a. (Godard 1988: 109)  
J’ ai rencontré Paul, [dont<sub>i</sub> [la maison <sub>-i</sub>] est à vendre].  
I have met Paul of.which the house is at sell.INF  
‘I met Paul, whose house is for sale.’
- b. (Godard 1988: 109)  
J’ ai rencontré Paul, [dont<sub>i</sub> il semblerait [que [la maison <sub>-i</sub>] est à vendre]].  
I have met Paul of.which it would.seem that the house <sub>-i</sub> is at sell.INF  
‘I met Paul, of whom it seems that the house is for sale.’
- c. (Godard & Sag 1996: 63)  
la jeune femme [dont<sub>i</sub> [le portrait <sub>-i</sub>] est à la fondation Barnes]  
the young woman of.which the portrait is at the foundation Barnes  
Barnes  
‘this young lady, of which the portrait is at the Barnes foundation’

Her conclusion is that the subject island constraint does not apply to NP subjects in French. However, she still thinks that extracting out of a verbal subject is impossible, as illustrated by (2.42). (2.42a) is extraction out of an infinitival, (2.42b) is extraction out of a finite sentential subject.

- (2.42) (Godard 1988: 43)
- a. \* Paul [[à qui]<sub>i</sub> il apparaissait que [confier ce qui s’ était Paul at who it appeared that confide it that REFL was réellement passé <sub>-i</sub>] était malheureusement impossible], really happened was unfortunately impossible serait certainement très en colère. would.be certainly very in rage  
‘Paul, to whom it appeared that, unfortunately, to confide what really happened was impossible, would certainly be very upset.’

### 2.3 The subject island constraint cross-linguistically

(i.e. It appeared that, unfortunately, to confide what really happened to Paul was impossible, and Paul would certainly be very upset.)

- b. \* Strasbourg [où<sub>i</sub> on sait que [la décision de fixer le  
Strasbourg where one knows that the decision of settle.INF the  
siège du Parlement européen -<sub>i</sub>] n' est pas encore  
seat of.the Parliament European NEG is not yet  
acquise] a pourtant effectué de grands travaux dans cette  
definitive has nevertheless made of big works in this  
perspective.  
respect

'Strasbourg, where it is known that the decision to settle the seat of the European Parliament is not yet definitive has nevertheless already undertaken big steps in that respect.'

(i.e. It is known that the decision to settle the seat of the European Parliament in Strasbourg is not yet definitive, but Strasbourg has nevertheless already undertaken big steps in that respect.)

As Godard (1988: 56) points out, the fact that extraction out of NP subjects is allowed in French is a major problem for the general theory: "It is explicitly expected that the [Subject Island] Constraint has a general scope and applies to French".<sup>20</sup>

In response to Godard (1988), Tellier (1990, 1991) hypothesizes that the reason why extraction out of the subject is possible with *dont* is that it is a complementizer. Consequently, according to Tellier, subextraction out of the subject is not allowed with *de qui*, as examples in (2.43) show.

(2.43) (Tellier 1990: 307)

- a. le diplomate [dont<sub>i</sub> [la secrétaire -] t' a  
the diplomat of.which the secretary you.ACC has  
téléphoné]  
called  
'the diplomat of who the secretary called you'
- b. \* le diplomate [[de qui]<sub>i</sub> [la secrétaire -] t' a téléphoné]  
the diplomat of who the secretary you.ACC has called  
'the diplomat of who the secretary called you'

<sup>20</sup>Translation. Original quote: "Or, il est explicitement prévu que la Contrainte ait une portée générale et s'applique au français." (Godard 1988: 56)

## 2 Syntactic approaches to the “Subject Condition”

The asterisk in (2.43) reflects Tellier’s judgements. The traditional indication of a subject island effect, namely the contrast between subextraction from subject vs. object, would arise if we replace *dont* with *de qui*, as expected by the subject island constraint. This is illustrated by (2.44), again with Tellier’s acceptability judgements.

(2.44) (Tellier 1991: 89–90)

- a. ?\* C’ est un linguiste [[de qui]<sub>i</sub> [les parents <sub>-i</sub>] ont déménagé à  
it is a linguist of who the parents have moved at  
Chartres].  
Chartres  
‘this is a linguist of whom the parents have moved to Chartres’
- b. C’ est un linguiste [[de qui]<sub>i</sub> vous avez rencontré [les  
it is a linguist of who you have met the  
parents <sub>-i</sub>]].  
parents  
‘this is a linguist of who you have met the parents’

Tellier’s (1990) analysis is based on the notion of “barriers”, as defined in Chomsky (1986) (this notion as explained in Section 2.2.2.2 page 31ff.). In her analysis, extraction out of the subject with *de qui* violates the subject island constraint, illustrated in Figure 2.13, similar to the English example (2.22).

Recall that following Chomsky (1986) the NP is not directly  $\theta$ -marked by the  $V^{21}$  and thus is a blocking category and a barrier for the PP-complement of the noun. The IP is not assigned a  $\theta$ -role either, and because it contains a blocking category (the NP), it is also a barrier for the PP. *Wh*-movement of *de qui* crosses two barriers, and is therefore unacceptable.

Tellier (1990: 308–309) says that the genitive PP-complement of the subject noun moves to the specifier of CP, where it agrees with the head (i.e., *dont*) and is then deleted. This is how *dont* receives genitive case. Because of this genitive case, the complementizer *dont* is L-marked (i.e. it is lexical).<sup>22</sup> Tellier stipulates (i) that an L-marked C head “ $\theta$ -marks its complement IP” and (ii) that a lexical  $\alpha$  “L-marks  $\beta$  iff  $\beta$  agrees with the head of  $\tau$  that is  $\theta$ -governed by  $\alpha$ ”. Her analysis is shown in Figure 2.14.

Because *dont* is lexical, C assigns a  $\theta$ -role to IP (i), which is thus not a blocking category. Additionally, *dont* L-marks the IP (ii) and the IP in turn assigns a  $\theta$ -role

<sup>21</sup>See fn. 9.

<sup>22</sup>She assumes that the overt genitive case “assigns to the complementizer sufficient lexical weight” for it to be treated as a lexical word (Tellier 1990: 309).

### 2.3 The subject island constraint cross-linguistically

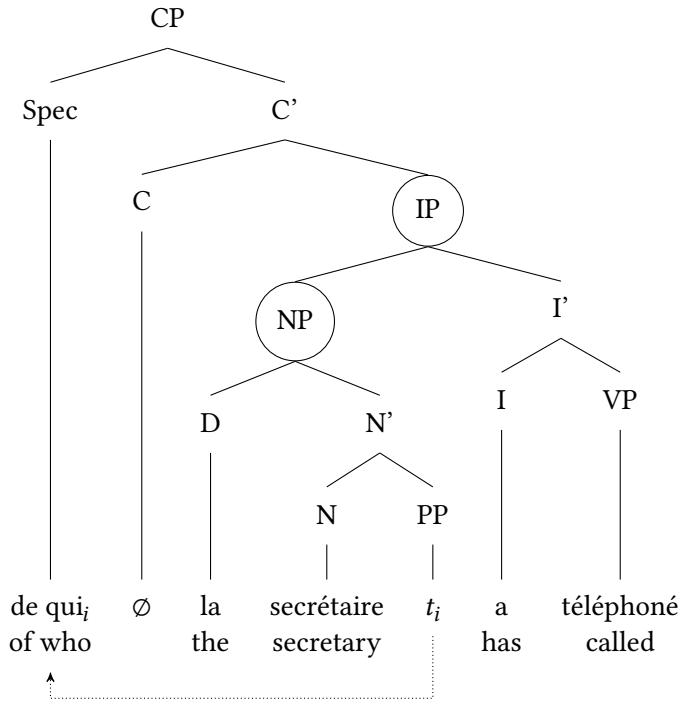

Figure 2.13: Syntactic tree for “[de qui]<sub>i</sub> [la secrétaire \_] a téléphoné” (‘of who the secretary called’) according to Tellier.

to the NP (i), which is thus not a blocking category, either. It then follows that there is no barrier in Figure 2.14 (the movement is 0-subjacent), and extraction out of the subject with *dont* is acceptable.

There are several problems with Tellier’s (1990) analysis. The proposal that *dont* can assign a  $\theta$ -role to the IP seems very stipulative and ad hoc, it only applies to subextraction from the subject. There is also no explanation for why the complementizer can only receive genitive and no other case, for example when extracting out of a sentential subject. Furthermore the premises are problematic as well. The judgements on the (un)acceptability of examples in (2.43) and (2.44) are Tellier’s, and have not been confirmed by quantitative empirical data so far. In particular, Godard (1988: 56) cites some felicitous examples of extraction out of a subject NP with *de qui* and dismisses a possible analysis along the lines of Tellier (1990).<sup>23</sup>

<sup>23</sup>“Il ne sert à rien de dire qu’il s’agit là d’une particularité de la forme *dont* par opposition aux mots *qu*” (Godard 1988: 56) (‘There is no use in saying that this is a peculiarity of the form *dont* as opposed to *wh*-words.’)

2 Syntactic approaches to the “Subject Condition”

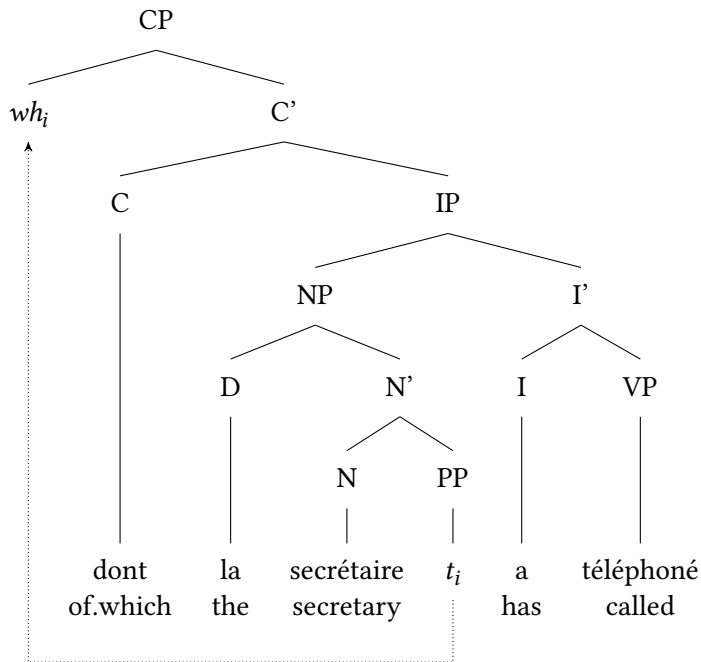

Figure 2.14: Syntactic tree for “dont<sub>i</sub> [la secrétaire -<sub>i</sub>] a téléphoné” (‘of who the secretary called’) according to Tellier

(2.45) (Godard 1988: 56)

- a. un homme [de qui]<sub>i</sub> [la force de travail -<sub>i</sub>] est étonnante  
 a man of who the power of work is astonishing  
 ‘a man whose work power is astonishing’
- b. [De qui]<sub>i</sub> te semblait - il que [la force de travail -<sub>i</sub>] est étonnante ?  
 of who you.DAT seemed it that the power of work is astonishing ?  
 astonishing  
 ‘Of who did it seem to you that the work power is astonishing?’

To conclude, French challenges the subject island in Minimalist accounts in various ways. First, the subject is by definition not a complement, so in accounts based on a distinction between complement and non-complement, extraction out of the subject should be impossible – except if extraction is allowed out of underlying objects, and this possibility should be tested empirically. Second, French is an SVO language, and the subject is considered to be base-generated in a specifier position (of IP, VP, vP or v\*P depending on the analysis), which means that



specifier-based accounts do not expect subextraction from the subject in French to be acceptable – except from subjects that are underlying objects, as just mentioned. Third, these accounts assume movement of the subject from Spec,VP to Spec,IP so analyses based on Freezing cannot explain why subextraction out of the subject is acceptable – except if extraction out of the subject happened to be restricted to postverbal subjects, but the examples discussed by Godard (1988), Tellier (1990, 1991) or Heck (2009) are not.

### 2.3.2 Other cross-linguistic counterexamples

French is not the only language that challenges the syntax-based accounts, and I now briefly present some other interesting data from the literature. The goal of this section is not to provide a complete list of languages that are relevant with respect to the Subject island Condition, but only to show that French is not exceptional.

#### 2.3.2.1 The subject as a non-complement

As mentioned before, Ross never intended the Sentential Subject Constraint as a universal constraint, because of data from Japanese, in which subextraction out of sentential subjects seems to be felicitous.

- (2.46) Japanese (Ross 1967: 244)  
Kore wa [[Mary ga – kabutte ita koto] ga akiraka na] boosi da.<sup>24</sup>  
this Mary wearing was thing obvious is hat is  
'This is the hat which that Mary was wearing (it) was obvious.'

Huang (1982) accounted for cases like Japanese and Chinese by proposing that Infl in these languages is lexical. The subject would then be properly governed, which would explain why it is possible to extract out of it.

More cross-linguistic counterexamples to the subject island constraint, have been included in the debate showing felicitous extraction out of subject NPs, infinitival subjects and sentential subjects. Stepanov (2007) offers a very complete collection of these counterexamples. His main goal in doing this is to show that accounts based on a distinction between complements and non-complements such as the CED cannot be correct. As he claims, languages that allow extraction out of the subject still exclude extraction out of adjuncts. If Huang's (1982) account were right, then adjuncts should be properly governed to the same degree as subjects, and subextraction from adjuncts should be acceptable.

---

<sup>24</sup>There is no relative pronoun in Japanese relative clauses, hence the lack of a filler coindexed with the gap in (2.46).

## 2 Syntactic approaches to the “Subject Condition”

Since then, the existence of adjunct islands has been challenged as well (Truswell 2011), but Stepanov’s (2007) argument against these accounts remains valid, because extraction out of subjects (and of adjuncts) should be completely ungrammatical. In particular, felicitous examples from English like (2.8) cited on page 25 are a problem. Santorini provides many attested examples of extraction out of NP subjects and Huddleston & Pullum and Chaves (2012: 17–18) give attested examples of extraction out of infinitival subjects.

(2.47) English

- a. (Jane Austen, *The complete novels* (1981: p. 84), cited by Santorini 2017)  
a letter [[of which]<sub>i</sub> [every line <sub>-i</sub>] was an insult]
- b. (David Quammen, *Natural acts: A sidelong view of science and nature* (1985: p. 176), cited by Santorini 2017)  
virginity and sans serif typeface, [[of which]<sub>i</sub> [the definition <sub>-i</sub>] must begin with negatives]
- c. (Huddleston & Pullum 2002: 1094)  
The eight dancers and their caller, Laurie Schmidt, make up the Farmall Promenade of nearby Nemaha, a town [that<sub>i</sub> [to describe <sub>-i</sub> as tiny] would be to overstate its size].
- d. (internet example cited by Chaves 2012: 18)  
The [...] brand has just released their S/S 2009 , [which<sub>i</sub> [to describe <sub>-i</sub> as noticeable] would be a sore understatement].

### 2.3.2.2 The subject as a specifier

As previously noted, Kayne’s (1983) Connectedness Condition was explicitly designed to account for the Japanese data, and for extraction out of the subject in SOV languages in general.

But felicitous counterexamples from Romance languages like (2.48) are problematic for the specifier-based accounts, because Romance languages are considered SVO.

- (2.48) a. Italian (Rizzi 1982: 61)
- questo autore, [[di cui]<sub>i</sub> so [che [il primo libro <sub>-i</sub>] è  
this author of which know.1SG that the first book has  
stato pubblicato recentemente]]  
been published recently  
'this author, of which I know that the first book has been  
published recently'

- b. Spanish (Jiménez-Fernández 2009: 103)  
 ¿[De qué cantante]<sub>i</sub> parece [que [algunas fotos <sub>-i</sub>] les  
 of which singer seems that some photos them.ACC  
 han escandalizado]?  
 have shocked  
 ‘Of which singer does it seem that some photos have shocked  
 them?’

This has led to the proposal that extraction out of subjects in Romance languages and the other languages listed by Stepanov (2007) is grammatical because no real extraction is involved (Rizzi 1990, Uriagereka 2011). In fact, all of these languages allow a null subject. Felicitous extraction out of the subject in Romance languages (2.48), Japanese (2.46), Turkish and many other languages would then be special instances of a null subject.<sup>25</sup> French is thus an interesting case, because it is a Romance language without a null subject.

Notice also that the data from English in (2.47) are a problem for these approaches as well.

### 2.3.2.3 The moved subject (Freezing analyses)

Lasnik & Saito (1992) adopt an analysis based on Freezing and account for Japanese data by assuming that the subject in Japanese is always in situ and does not leave the VP.<sup>26</sup>

As mentioned previously, Gallego & Uriagereka (2007) claim that in Spanish, extraction from preverbal subjects is ruled out, while extraction from postverbal subjects is felicitous. They take this as evidence that the subject island phenomenon is caused by Freezing effects: movement of the subject to Spec,TP blocks the subsequent *wh*-movement from the subject to Spec,CP. Jiménez-Fernández (2009) criticizes this distinction between preverbal and postverbal subjects in Spanish, on the basis of examples like (2.48b).<sup>27</sup> Thus there is disagreement about

<sup>25</sup>Huang (1984) also proposes something similar for Mandarin. He assumes that acceptable extraction out of an island is not actual extraction, and the gap is not an actual gap, but rather a null pronoun, which is licensed because its referent is the nearest preceding NP. His analysis works particularly well for subject islands, since the (false) gap is by definition near the filler. For a refutation of Huang (1984), see Dong et al. (2021: 2–3).

<sup>26</sup>As pointed out by Stepanov (2007),  $\theta$ -role assignment must then be completely reconsidered.

<sup>27</sup>Notice that the extracted element in (2.48b) is specific, and that the subject is an indefinite, two factors that contribute to make the sentence more acceptable. I will come back to this aspect in Section 3.4.

## 2 Syntactic approaches to the “Subject Condition”

the data from Romance languages and about a possible asymmetry between pre-verbal and postverbal subjects.

Also, the analyses based on Freezing predict that extraction out of subjects of passives is ungrammatical because these subjects undergo movement (except in some languages like German where the movement is optional). Under many of the other analyses, however, extraction out of subjects of passives is grammatical. This results in disagreement about the data for passives as well: see examples (2.11) and (2.12) on page 26.

Finally, an interesting point is raised by Chaves & Putnam (2020): not only subextraction from moved subjects, but also subextraction out of extracted elements should be impossible according to Freezing accounts. But this is not always the case, as the following example shows:

- (2.49) (Chaves & Putnam 2020: 52)  
This is the handout [which<sub>i</sub> I can't remember [[how many copies of <sub>-i</sub>]<sub>j</sub> we have to print <sub>-j</sub>]].

## 2.4 Criticisms of the syntactic approach

We already saw that there is some disagreement concerning the data about the subject island cross-linguistically as well as concerning extraction out of certain kinds of subjects. This is not only due to a lack of empirical data, but also to a problem of interpreting the data, when available. As a matter of fact, it is hard to draw the line between “good” extractions and “bad” extractions, because there are numerous ways to improve an infelicitous subextraction from a subject. But precisely this point is problematic, for several reasons that I elaborate on in this section.

### 2.4.1 Non-syntactic factors increasing the acceptability

Especially researchers working on sentence processing have been criticizing syntactic analyses of islands for a long time. Without going into details, as it will be the focus of Chapter 3, their principal claim is that an island caused by a syntactic constraint should not increase in acceptability unless we manipulate syntactic factors. If non-syntactic factors ameliorate an island violation, this means that the superadditivity effect is not caused by a syntactic constraint. This criticism of islands in general was formulated by Kluender (1991, and later works), then adopted by Hofmeister & Sag (2010, and later works) and is now supported by Chaves (2013, and later works).

Regarding the subject island in particular, Chaves has shown that many non-syntactic factors can improve extraction out of subjects (especially, but not exclusively, subject NPs).

1. Semantic factors like definiteness and specificity help improve subextraction from NPs in general, not only for subjects (Jiménez-Fernández 2009, Chaves 2013, Simonenko 2016, see Section 3.4). Notice that some proponents of syntax-based approaches posit different syntactic structures for definite and indefinite NPs, so these factors can be addressed by a syntactic analysis.
2. Appropriate prosody can help identify the gap more easily and make sentences with extraction out of the subject more acceptable (Chaves & Dery 2014).
3. Change in lexical material without modifying the syntactic structure can help change the proposition expressed by the utterance and make extraction more felicitous, because the purpose of the utterance (e.g. why one may need to ask such a question) is easier to understand (Chaves & Dery 2019).
4. With repeated exposure to extraction out of the subject, naive speakers increasingly accept the structure (Chaves & Dery 2014, Do & Kaiser 2017). This effect is known as “satiation”, or “habituation”. Ungrammatical sentences usually do not show habituation effects (Sprouse 2007b).

### 2.4.2 “Parasitic” gaps

An early observation made about subextraction from subjects in English is that the extraction of the subject is far more acceptable if the gap is related to another gap situated in a non-island environment. For example, in (2.50), we see that subextracting out of the subject is more felicitous if there is a second gap in the object.<sup>28</sup>

---

<sup>28</sup>This is supposed to hold cross-linguistically and for all constructions that involve extraction. Tellier gives the following contrast for French:

- (i) (Tellier 1991: 122)
- a. \* un enfant [[de qui]<sub>i</sub> [les parents <sub>-i</sub>] ont déménagé]
   
a child of who the parents have moved
   
'a child whose parents have moved'

## 2 Syntactic approaches to the “Subject Condition”

(2.50) (Chaves 2013: 303)

- a. \* What<sub>i</sub> did the attempt to repair <sub>-i</sub> ultimately damaged the car?
- b. What<sub>i</sub> did the attempt to repair <sub>-i</sub> ultimately damaged <sub>-i</sub>?

Syntactic-based accounts of subject islands have all addressed this contrast. They usually assume that only the gap in the non-island environment is a “real” gap. The first missing element in the subject phrase is a null pronominal which is only felicitous because of the actual extraction. This phenomenon is known as a “parasitic gap”: the gap in the subject is “parasitic” as it takes advantage of the presence of the legitimate gap. Parasitic gaps are supposedly allowed in adjuncts for similar reasons.

Chaves has worked extensively on so-called parasitic gaps and presents many examples that are problematic for syntax-based accounts. I reproduce here only a few of them, but I invite the interested reader to consult Chaves (2013) and Chaves & Putnam (2020) for further discussion of the phenomenon.

It is true that a second coindexed gap can improve the acceptability of an unacceptable gap. For example, in (2.51a), the second gap requires an NP, while the filler is a PP, but since the filler is appropriate for the first gap, the sentence is unproblematic. As the contrast with (2.51b) shows, though, it makes a difference whether the filler-gap mismatch is at the first or at the second gap.

(2.51) (Chaves & Putnam 2020: 62, my emphasis)

- a. It was *on Sue* [that<sub>i</sub> I think Sam relied <sub>-i</sub> the most but didn’t thank <sub>-i</sub>? nearly enough in his speech].
- b. \* It was *on Sue* [that<sub>i</sub> I think Sam thanked <sub>-i</sub>? the most but didn’t rely <sub>-i</sub> nearly enough in his speech].

Given that subjects precede objects, the subject gap is the first one, and hence unlikely to be parasitic. When perceivers first encounter the subject, they would probably not realize that it contains a gap. This would only become clear when they reach the second gap, which would then be too late to posit one in the subject “after the fact” (this is what happens in 2.51b). Such a process would require reanalysis, and online measurements would show a slowdown. According to Chaves & Dery (2019), this is not the case.

- 
- b. un enfant [[de qui]<sub>i</sub> [les parents <sub>-i</sub>] se méfient <sub>-i</sub>]  
a child of who the parents REFL beware  
'a child whom the parents of beware'

Whether the contrast between (ia) and (ib) is real has not been tested empirically so far. See also Godard (1988: 117–119) on so-called “parasitic gaps” in French.

The contrast between (2.52c) and (2.52a) is the same as the contrast in (2.50). Again, extraction out of the subject is improved by the presence of a second gap. However, in (2.52c), the second gap is inside an adjunct. Since extraction out of adjuncts is not felicitous (and supposedly a violation of an island constraint), as shown by example (2.52b), none of the gaps can be “parasitic” on another legitimate gap. This example shows that what must be happening is reactivation of the filler, which makes the structure easier to process. It cannot be explained by parasitic licensing.

(2.52) (Chaves 2013: 305)

- a. \* [What kinds of books]<sub>i</sub> do [authors of <sub>-i</sub>] argue about royalties after writing malicious pamphlets?
- b. ?? [What kinds of books]<sub>i</sub> do authors of malicious pamphlets argue about royalties [after writing <sub>-i</sub>]?
- c. [What kinds of books]<sub>i</sub> do [authors of <sub>-i</sub>] argue about royalties [after writing <sub>-i</sub>]?

In example (2.53), again, extraction out of the object causes the extraction out of the subject to become more acceptable. But since the two gaps are not coindexed, the one in the subject cannot be a parasitic gap.

(2.53) (Chaves 2013: 305)

[People that sensitive]<sub>i</sub>, I never know [[which topics]<sub>j</sub> [jokes about <sub>-j</sub>] are likely to offend <sub>-i</sub>].

Instead of parasitic licensing, Chaves proposes an analysis based on cognitive principles (Chaves 2013, Chaves & Dery 2014, 2019). When first encountered, the filler needs to be kept in memory. The comprehender then accesses this memory representation when they identify a gap and need to fill it. This process reactivates the referent of the filler, so it becomes cognitively more salient than it was before the first gap. At the second gap, the referent of the filler is still salient, so the process of accessing this piece of information is facilitated. This view is supported by independent evidence from processing in Vasishth & Lewis (2006).<sup>29</sup>

### 2.4.3 Gradient grammaticality

Finally, I cannot avoid the sensitive topic of gradient acceptability of island structures in general (Hofmeister & Sag 2010, Hofmeister et al. 2013), and of subject

<sup>29</sup>Furthermore, having a second gap where the gap is most expected, as in (2.50b), helps avoid a potential filled-gap effect, see Section 3.1.

## 2 Syntactic approaches to the “Subject Condition”

islands in particular (see Part II of this book). It seems that judgments on subextraction from the subject vary from case to case, and range from completely unacceptable to perfectly acceptable with everything in between. But this variation has been interpreted in different ways.

The problem is rooted in the relation between acceptability and grammaticality.<sup>30</sup> Everyone agrees that there must be at least a correlation between acceptability and grammaticality. Generally speaking, a sentence that (i) is licensed by syntactic rules, (ii) is not semantically incoherent, and (iii) is consistent with pragmatic principles such as Grice’s maxims, is also an acceptable sentence in all but exceptional cases – like center-embedded structures, whose unacceptability can likely be explained by cognitive processing limitations. However, is the reverse also true? And in particular: Is a sentence that is ungrammatical from the syntactic point of view also unacceptable? And where is the threshold between acceptability and unacceptability? When is a sentence acceptable enough to falsify a syntactic hypothesis?

A common criticism against syntactic approaches is that they are not able to explain acceptability judgments in the grey area between acceptability and non-acceptability. Syntax is discrete: a sentence either belongs to a given language or it does not. Erteschik-Shir expresses it in the following terms:

Violations of syntactic constraints necessarily cause strong grammaticality infractions, thus resulting in ungrammatical sentences.

(Erteschik-Shir 2006: 335)

Erteschik-Shir’s opinion is shared by many others (e.g. Chaves 2013, Hofmeister & Sag 2010, Abeillé et al. 2020), and even by some supporters of the syntactic approaches (Sprouse 2007b). Since judgments on (some) islands are gradient, their conclusion is that syntactic approaches to these islands cannot account for the gradience of the actual data.<sup>31</sup> Alternatives are processing-based

---

<sup>30</sup>I will not go into detail about the exact definition of grammaticality and acceptability, which has been discussed at length by other scholars (a.o. Schütze 2016). Let us only assume that acceptability is the graded subjective judgment that reflects a native speaker’s perception of a given utterance, regardless of the reason why they may find the utterance good or bad. Grammaticality, on the other hand, is a theoretical construct: a given sentence may or may not follow the syntactic, semantic and pragmatic rules of a given language and thus be part of the (potentially infinite) set of sentences that belong to this language.

<sup>31</sup>As far as experimental data are concerned, Sprouse (2007b), who argues in favor of syntax-based accounts of subject islands, denies the gradience of the data, and says that a distinction between acceptability and unacceptability judgments can be observed if one uses adequate methodology.



and discourse-based accounts, which can straightforwardly explain this gradience (see Chapters 3 and 4).

And yet, the question of the gradience of grammar is very often explicitly addressed by the linguists who develop the syntactic accounts. For example, Subadjacency was first categorical (Chomsky 1973) but was soon formulated as a constraint that explicitly expects graded grammaticality proportional to the number of barriers crossed during the movement (Chomsky 1986).

Rules of grammar do not simply apply or fail to apply; rather they apply to a degree. [...] Grammatical constructions are not simply islands or non-islands; rather they may be islands to a degree. (Lakoff 1973: 271)

The real problem is hence the fact that these linguists have not managed to explain convincingly how their syntactic rules allow ungrammatical structures to be acceptable, or how violation of a constraint can lead to half-grammaticality. In syntactic theories that make a distinction between syntax, LF and PF, syntactic constraints should block the transfer to LF. It follows that a sentence that violates a syntactic rule cannot be interpreted at all, since the transfer that would enable the interpretation has failed. If this were the case, then acceptable violations of a syntactic rule could only be considered to be a grammatical illusion, and native speakers should not be able to understand such sentences. We will see that this is not the case in extraction out of the subject. Furthermore, a theory that postulates the innateness of syntactic constraints needs to explain why there is a distinction in strength between these innate rules. In my view, Uriagereka (2011: Chapter 1) takes this problem seriously and dedicates some effort to explaining the link between processing and syntactic constraints. He sees constraints as merely preferences – strong preferences, but ones that can still be subverted. Similarly, in Optimality Theory, constraints are seen as criteria, and the structure that violates the fewest criteria “wins” in being the most acceptable (Keller 2000).

Of course, there is also an opposite view, according to which discrete grammaticality can nevertheless lead to non-discrete acceptability judgements “as by-products of interactions of grammatical knowledge with the behavioral systems required to perceive, comprehend, and intuit” (Carroll 1979: 871–872). The gradience of data is attributed to the human capacity to find a solution – any solution – to a problem. Since the purpose of verbal communication is the exchange of information, the comprehender finds a way to interpret sentences, even if they do not belong to the language.<sup>32</sup>

---

<sup>32</sup>A concrete example is the common experience that we are able to correctly interpret utterances

## 2 Syntactic approaches to the “Subject Condition”

According to Schütze (2016), there is actually no empirical way to distinguish between the two views:

It might be that the nature of the particular tasks used by prototype theorists (and linguists) inherently induces graded behavior, independent of the nature of the underlying knowledge. If this is so, the status of that underlying knowledge as discrete or continuous must be demonstrated by other means. But how could we ever know whether a grammar, if it exists independent of performance mechanisms, classifies sentences dichotomously? If performance mechanisms induce graded structure by themselves, and if (as I argue) they can never be circumvented because competence is not directly accessible, then it might not be possible to investigate empirically how a grammar itself classifies sentences. (Schütze 2016: 69)

In the empirical work I present later, I have done my best to take into account this difficult issue. First, I postulate that an ungrammatical structure should appear in well-edited written production only in extremely exceptional cases (if at all). The problem then is to define “extremely exceptional”. I therefore establish an objective threshold; constructions with fewer occurrences are considered marginal or hardly existent. In the experiments, I employed a methodology proposed by Sprouse (2007a) in which a factorial design is used in order to detect superadditivity effects. This design does not allow us to identify the reason of the superadditivity – whether it is caused by syntax, processing or pragmatic factors – but it enables us at least to clearly identify a contrast in acceptability. In most experiments, I added an ungrammatical baseline. I chose the baseline in such a way that the ungrammatical sentences are nevertheless somewhat comprehensible. Thus, it is possible to see whether participants discriminate between a violation of the subject island constraint and ungrammatical-but-interpretable sentences.

### 2.5 The subject island constraint in HPSG

Before presenting the processing-based and discourse-based accounts of subject islands, let me briefly sketch the way this phenomenon has been analyzed in HPSG. The first approaches were indeed syntax-based, and some islands (extraction of a conjunct and subextraction from relative clauses) are still treated in terms of syntactic constraints. But the analysis of subextraction from subjects has changed over the years.

---

of non-native speakers that contain grammatical errors, as an anonymous reviewer rightly pointed out.

In HPSG, filler-gap dependencies are not conceived of as movement. The information that the verbal phrase is missing an element is stored in a nonlocal feature *SLASH*, so that the missing element can be saturated on the clausal level. The first formalization of the *SLASH* feature is in Gazdar (1981), where the information that an element is missing is percolated from daughter to mother in the same way as other kinds of information. This analysis is compatible with online processing data on filler-gap dependencies: The resolution of filler-gap dependencies seems to take place at the subcategorizer, and not at the gap site (Boland et al. 1995, Traxler & Pickering 1996). In current HPSG analyses, there are two ways to treat these missing elements: either as empty categories or through a lexical rule.

Early GPSG had an equivalent to the Subject Island Condition. In Pollard (1984), the Binding Inheritance Principle makes sure that mother nodes cannot inherit an element in *SLASH* from a specifier. Pollard & Sag (1994) have a Subject Condition (2.54) that allows parasitic gaps in the subject but no other gaps. However, the authors explicitly state that this constraint is not universal, but possibly only belongs to the grammar of English. Even this is not certain, given that “many [English] speakers” consider extraction out of the subject acceptable (Pollard & Sag 1994: 183).

- (2.54) A lexical head’s *SUBCAT* list may contain a slashed subject only if it also contains another slashed element. (Pollard & Sag 1994: 200)

Hence, what Pollard & Sag ultimately say is that a syntactic island constraint is possible in the HPSG formalism, but they leave open the question of whether it should be used in the case of subject islands. Subsequent work on extraction has abandoned this Subject Condition (Godard & Sag 1996, Sag 1997, Bouma et al. 2001, Sag 2010, Chaves & Putnam 2020), which is probably motivated by the lack of evidence that a subject island constraint exists. Godard and her remarks on French *dont* relative clauses may have played an important role in this change. Still, Levine & Sag (2003) go back to the idea of an English-specific syntactic constraint for subject islands, but their approach is the exception rather than the rule.

In conclusion, as far as the subject island is concerned, we can see that there is a *de facto* difference between HPSG accounts and analyses proposed in a “Chomskyan” tradition of generative grammar. The HPSG analysis I develop in Part IV of this book is in line with a general tendency of HPSG because I adopt a discourse-based approach to the phenomenon. This is motivated by empirical evidence that I present in the rest of this work. However, this does not mean that

## *2 Syntactic approaches to the “Subject Condition”*

a syntax-based analysis of the subject island is inherently impossible in HPSG. Syntax-based accounts have been proposed in the past. Simpler Syntax borrows from HPSG the analysis of filler-gap dependencies (“discontinuous dependencies”) through a feature `SLASH`, but has a syntactic constraint for extraction out of subjects (Culicover & Jackendoff 2005: 332). To my knowledge, this is also the state of the art in Lexical Functional Grammar. At the same time, Erteschik-Shir (1973) has shown that a discourse-based analysis of islands phenomena is possible in the framework of Transformation Grammar.

## 3 Processing approaches

### 3.1 General mechanisms of processing associated with extraction

Language is used in two different ways: production (generation) and comprehension (parsing), performed respectively by an addressor (speaker, writer or signer) and an addressee (hearer or reader). Different linguistic resources are needed to perform these two tasks: a common grammar, procedures for constructing representation during comprehension, and procedures for building sentence structures during production (Momma & Phillips 2018: 236-237). There is compelling evidence that the latter two mechanisms (construction of representation and sentence structure building) appeal to common cognitive resources. For example, agreement attraction<sup>1</sup> happens similarly in production and comprehension tasks. I will therefore adopt here Momma & Phillips's (2018) view that the two mechanisms are related, though this is still debated.

I here use the term "processing" to account for the cognitive process of using these linguistic knowledge resources. Some utterances involve more processing costs than others, in both production and comprehension.

Extraction is known to cause processing difficulty. Structures with gaps are harder to process than structures without gaps (Wanner & Maratsos 1978, Klender & Kutas 1993b). A variety of models exist in order to account for the distribution of costs in these structures. I present in Section 3.2 the model adopted by the Dependency Locality Theory (DLT) in detail. But online experiments reveal at least two main processing difficulties, one due to the filler and the second due to the gap.

---

<sup>1</sup>Agreement attraction is a particular linguistic illusion involving ungrammatical agreement that is perceived by a large number of native speakers as grammatical under certain conditions. For example, participants in experiments are very likely to accept a sentence like (i):

(i) The bed by the lamps were undoubtedly quite comfortable. (Schlueter et al. 2019)

#### 3.1.1 Processing cost for the filler

The first processing cost is incurred at the filler site. During comprehension, the phenomenon is called “active gap search”: As soon as the filler is encountered, it is recognized as a signal for an upcoming gap, and processing mechanisms start to postulate potential gap sites. This induces memory costs (for remembering the morphosyntactic properties of the filler), but also costs for anticipating the potential gap sites. One consequence of the latter are so-called filled-gap effects. Discovering that a postulated (because highly probable) gap site is already filled produces additional processing costs (Stowe 1986). For example, in a self-paced reading experiment conducted by Stowe, participants had to read the sentence (3.1a) word by word. When they reached the end of the fragment in (3.1b), they presumably postulated a gap in the object position, because an increase of the reading times (linked to additional processing costs) was measured on the direct object *us*. Scholars generally assume that the reader has to re-anticipate the next probable gap site when the most probable one is already filled. This is linked to additional processing costs.

(3.1) (Stowe 1986: 234)

- a. My brother wanted to know who<sub>i</sub> [Ruth will bring us home to <sub>-i</sub> at Christmas]
- b. My brother wanted to know who Ruth will bring...

Less work has been done on the processing costs during generation. Production errors show that it is difficult for the speaker to anticipate the gap site and choose the correct filler accordingly. In a very typical disfluency during spontaneous speech, the speaker begins a structure involving an extraction, commits to a certain filler, and realizes later in the clause that the filler is illicit (Momma & Phillips 2018: 243).

#### 3.1.2 Processing cost for the gap

The second processing cost is incurred when the integration of the information from the filler takes place. Again, the phenomenon has been well studied in comprehension, but less so in production. Intuitively, it is easy to understand how identifying a gap site can be hard for the addressee. By definition, a gap is not overtly signaled in the sentence, and there is also no overt indication whether a filler is linked to one or to several gaps. But beyond this first intuition, there is also empirical evidence that the “resolution” of the filler-gap dependency is associated with processing costs.

### 3.2 Dependency-length minimization

Kaan et al. (2000) have shown by recording online event-related potentials (ERPs) in reading experiments that integration elicits P600 effects<sup>2</sup>, such that the more complex the integration is, the higher the amplitude of the P600. Note that this integration cost has been observed at the subcategorizing head (the P600 peaks around 600 ms after the verb's onset when extracting an argument of the verb).

Momma et al. (2019) also present preliminary results that seem to indicate that some additional costs are associated with the integration of the gap. Taking advantage of the PP/NP alternation in English with *give*-like ditransitive verbs (the benefactive can be expressed as a PP or NP), they made participants produce interrogatives with extraction of the PP object (the only felicitous variant in interrogatives), with and without prior priming for the NP variant. They observe a slowdown in producing the verb when participants were primed for the NP variant, see example (3.2). This indicates that the integration of the filler is taking place when planning the subcategorization of the verb: participants notice that the structure they have been primed to is not felicitous and take more time to integrate the gap with the appropriate syntax.

- (3.2) *Priming*: The girl is reading the boy the book.  
*Production*: Who is the doctor *giving* the trumpet to?

These observations suggest that extraction is a syntactic mechanism that brings with it big additional processing costs. In this chapter, I will present two main approaches to subextraction from subjects from a processing point of view. These approaches make opposite predictions for subextraction from the subject: under processing accounts based on memory costs, it should be easier to process than subextraction from the object (no “subject island” effect), while processing accounts based on relevance and surprisal predict an increase of processing costs associated with subextraction from (sentential, infinitival or NP) subjects.

## 3.2 Dependency-length minimization

I will present two accounts based on dependency-length minimization, the DLT and Dependency Grammar. Both have their origin in the Active Filler Hypothesis (Frazier 1987, Clifton & Frazier 1989), which states that when one encounters a filler (or a cue that a gap is coming), one postulates the closest possible gap. Because filler-gap dependencies are cognitively costly, the longer the distance between the filler and the gap, the the longer one has to keep the content of the

---

<sup>2</sup>P600 = The waveform of the ERPs has a positive peak around 600 ms after the word onset.

### 3 Processing approaches

filler in memory (Fadlon et al. 2019). As a consequence, the mental representation of the filler becomes weaker as the distance to the gap increases (Lewis & Vasishth 2005). This also has an impact on sentence production, because of a cooperation principle between the speaker and the addressee: the speaker tries to make the sentence as easy to understand as possible, while the addressee tries to make sense of the sentence to the best of their capacity. This results in a general preference in language to minimize the distance between the filler and the gap.

Some processing-based models of filler-gap dependencies, therefore, predict that shorter distances between the filler and the gap are easier to process, leading to an increased acceptability. Depending on the model, the distance may be measured in terms of linear distance (Gibson 1998, 2000) or in terms of structural distance (Rizzi 1990, Hawkins 1999). Both approaches lead to similar expectations, and make the same predictions in the case of subextraction from the subject, namely that extraction out of the subject should actually be easier than extraction out of the object, because the dependency (be it linear or structural) between the filler and the gap (or between the filler and the subcategorizer of the gap) is shorter in extraction out of subjects.

One important issue is the asymmetry between subject vs. object relative clauses: Subject relative clauses are easier to process than object relative clauses and are rated higher in acceptability judgment tasks (Holmes & O'Reagan 1981; Wanner & Maratsos 1978 and many more). A classical example in the literature is the contrast in (3.3) between an extraction of the subject (3.3a) and of the object (3.3b).

- (3.3) (Gibson 1998: 20–21)
- a. The reporter [who<sub>i</sub> –<sub>i</sub> attacked the senator] admitted the error.
  - b. The reporter [who<sub>i</sub> the senator attacked –<sub>i</sub>] admitted the error.

This asymmetry holds cross-linguistically and is attributed to the shorter (linear and structural) distance between filler and gap in (3.3a) than in (3.3b). Hawkins (1999: 252–256) emphasizes the similarity between dependency-length minimization strategies (not only for filler-gap dependencies) and the Accessibility Hierarchy of Keenan & Comrie (1977).<sup>3</sup> The subject island constraint seems to go

---

<sup>3</sup>The Accessibility Hierarchy is a typological hierarchy of arguments. The hierarchy in Keenan & Comrie (1977) is the following: Subject > Direct Object > Indirect Object > Oblique > Genitive > Object of comparative (in subsequent works of Keenan & Comrie, Indirect Object and Oblique are collapsed into one). One observation of Keenan & Comrie (1977) is that languages that allow only one type of extraction (e.g., Maori) allow the extraction of the subject; languages with two extraction types (e.g., Luganda) allow the extraction of the subject and of the direct object, and so forth.



against all expectations of the dependency-length minimization strategies, but also against Keenan & Comrie's (1977) Accessibility Hierarchy.

### 3.2.1 Dependency Locality Theory (DLT)

Gibson (1998, 2000) proposes the Dependency Locality Theory (DLT), a cognitive model of sentence processing with a particular focus on filler-gap dependencies. This model identifies two costs of cognitive resources involved in filler-gap dependencies: (i) memory costs and (ii) energy costs. Memory costs are caused by the need to store the predictions made about the upcoming structure as the sentence continues, e.g. predictions on the gap site (see above). Energy costs, on the other hand, are caused by the need to integrate every new word into the structure.

These integration/energy costs are twofold.

1. For every new referential word, a new referent must be introduced in the discourse representation. As a simplification, Gibson assumes a cost of one unit of energy for each new discourse referent. Pronouns are either anaphoric or deictic and do not introduce any new referent.
2. Furthermore, filler-gap dependencies (or any other dependency) also imply additional energy costs for every referent introduced between the filler and the gap. As a simplification again, Gibson assumes a cost of one unit of energy for each new discourse referent.

We can illustrate the DLT with (3.4), in which the latter kind of energy costs are indicated below each new referent (memory costs and costs for introducing more referents are the same in both sentences).

- (3.4) a. The reporter [ $\text{who}_i$   $_{-i}$  attacked the senator] admitted the error.  
           0                  0                  0                  0                  0          = 0
- b. The reporter [ $\text{who}_i$  the senator attacked  $_{-i}$ ] admitted the error.  
           0                  1          1                  0                  0          = 2

The integration costs are higher in the object relative clause than in the subject relative clause, given that the filler-gap dependency adds no cost in the latter but two units of energy in the former.

If we apply DLT to extraction out of the subject vs. the object, it is obvious that extraction out of (preverbal) subjects create lower energy costs in English and French: the head of the NP introduces at least one new referent for both, but in extraction out of the object, the verb and the subject intervene between the filler and the gap and introduce new referent(s) (if the subject is not pronominal).

### 3.2.2 Dependency Grammar

Dependency Grammar (DG) represents syntactic dependencies by means of a dependency graph like (3.5).

(3.5)

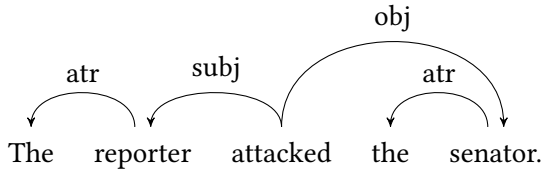

A central concept in DG is projectivity. The sentence in (3.5) contains only projective dependencies, because the dependency arrows never cross. Many non-local dependencies lead to non-projective structures. Projectivity is considered in DG to be one of the factors determining word order: The language tries to avoid non-projectivity whenever possible (see Hudson 2010: Section 7.4.2; Osborne 2019: Section 7.3). Non-local dependencies can override this requirement because extraction (“displacement” in DG) is pragmatically highly motivated (Hudson 2010: Section 7.6.7). But short-distance dependencies do not necessarily lead to non-projectivity. Interestingly, subextraction from the subject mostly results in projective structures, as noticed by Candito & Seddah (2012a: Section 4.3). An example can be seen in (3.6).<sup>4</sup>

(3.6)

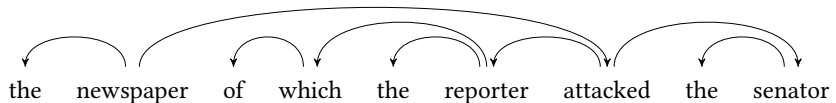

Additionally, word order is constrained by Dependency Distance. For reasons similar to the ones mentioned for the DLT, Dependency Distance should be reduced whenever possible. Liu et al. (2009) propose a method to measure Mean Dependency Distance (MDD) by adding up the number of words that every dependency arrow has to cross from the beginning to the end of the dependency (see also Liu 2008). The shortest Dependency Distance is one, except for the main

<sup>4</sup>For the dependency graphs, I adopt the rules of Universal Dependency Grammar, widely used for annotating corpora in DG: nouns are heads of NPs and select their determiner; nouns are heads of PPs and select their preposition. Some scholars, however, prefer treating the determiner as the head of DPs, and/or the preposition as the head of PP. This alternative analysis would have no impact on projectivity in my examples.

### 3.2 Dependency-length minimization

verb of the matrix clause, which is not selected and therefore has a Dependency Distance of zero. In (3.7), from Liu (2008: 167), we can see how the asymmetry in (3.3) is accounted for in DG. The Dependency Distance of each dependency is indicated under the dependency arrow-head. The subject relative (3.7a) has an MDD of 1.875, and is for this reason preferred over the object relative (3.7b), which has an MDD of 2.25.

(3.7) a.  $MDD = 15/8 = 1.875$

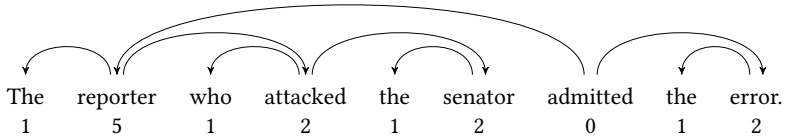

b.  $MDD = 18/8 = 2.25$

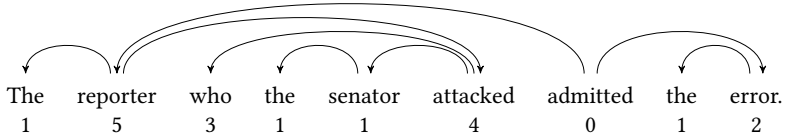

If we apply the same method to measure the MDD of subextraction from subject and object NPs, it gives us the results in (3.8). The extraction out of the object in (3.8b) not only has a higher MDD than the extraction out of the subject in (3.8a), but is also non-projective.<sup>5</sup>

(3.8) a.  $MDD = 14/9 = 1.556$

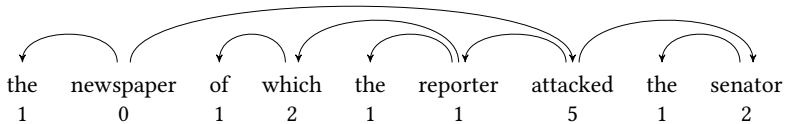

b.  $MDD = 17/9 = 1.889$

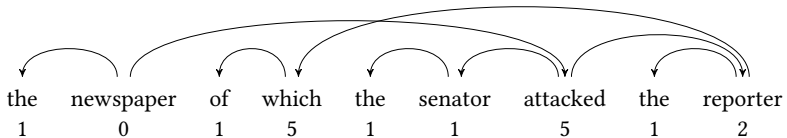

<sup>5</sup>Notice that in English interrogatives, because of the presence of the auxiliary, extraction similar to (3.8a) would be non-projective, while extraction like (3.8b) would be projective. Yet, the extraction out of the object would have a higher MDD, like in relative clauses.

### 3 Processing approaches

Hence, based on Dependency Distance, extraction out of the subject should be easier to process than extraction out of the object. This is not to say that extraction out of the subject is usually analyzed this way in DG. Bröker (1999: 58–59), Hudson (2010: 186) and Osborne (2019: Chapter 9) treat islands in a relatively traditional manner as blocking some kinds of dependencies. Bröker addresses extraction out of infinitival subjects and sees it as a constraint on dependencies over dependencies. Osborne (2019: Section 9.7) describes sentential and NP subject islands, and proposes that “rising catenae reluctantly include a normal dependency that bears the subject grammatical function” (Osborne 2019: 286). He notices, however, that acceptability judgments on such structures are “not always clear” (Osborne 2019: 285). Consequently, we can see that DG’s approach to subject island does not much differ from the traditional syntactic accounts, but projectivity and Dependency Distance make interesting predictions nonetheless.

## 3.3 Processing accounts based on surprisal

### 3.3.1 Processing difficulty of subjects

In this section, I summarize the analysis proposed by Kluender (2004), which, to my knowledge, is the most articulated argumentation around the idea that superadditivity effects in extraction out of subjects arise from the fact that subjects (and especially complex subjects) are hard to process.

#### 3.3.1.1 Processing difficulty for subjects

There is strong evidence that non-finite clauses are easier to process than finite ones. Ross (1967: 27) already noticed that extractions out of an embedded question (so-called “*wh*-islands”) are more felicitous if this embedded question is non-finite, and therefore has no overt subject.

(3.9) (Ross 1967: 27)

- a. He told me about a book which I can’t figure out how to read.
- b. ?? He told me about a book which I can’t figure when I should read.

Kluender (2004: 106) also points out that extraction out of relative clauses, albeit always very degraded, is still easier to process when the relative clause is non-finite.

(3.10) (Kluender 2004: 106)

- a. ? That's the campaign that I finally thought of someone to spearhead.
- b. ?? That's the campaign that I finally thought of someone who could spearhead.

Kluender (2004: 110) explains the contrasts in acceptability illustrated by (3.9b) and (3.10b) by hypothesizing that overt subjects have a “greater discourse referential processing cost” than covert ones. Obviously, this is based on the assumption that subjects in non-finite clauses are covert. But if one posits that there are no subjects in non-finite clauses, the DLT predicts the contrast between extraction out of finite and non-finite clauses: one referent less (the subject) reduces the integration costs. This is not related to the syntactic function of the subject. Furthermore, in DLT, only finite verbs introduce a new referent in discourse (because only tensed verbs have a spatiotemporal location, Gibson 2000: 103). The DLT can therefore explain why extraction out of non-finite relative clauses is easier to process.

Further evidence comes from a study by Clark & Wasow (1998), also mentioned by Kluender (2004: 114). Clark & Wasow (1998) conducted a study on two corpora of spontaneous oral speech in English, the Switchboard corpus (Godfrey et al. 1992) and the London-Lund corpus (Svartvik & Quirk 1980), and looked at a certain form of disfluencies: repetitions. Among 353,820 pronouns repeated, 173,348 (49%) were nominative pronouns, like in (3.11). As a comparison, only 19,927 (5.6%) were accusative pronouns (Clark & Wasow 1998: 215). They also found a ratio of 45 repetitions of the determiner *the* of simple subject NPs against 30 repetitions of *the* in simple object NPs per 1,000 NPs (Clark & Wasow 1998: 213). In both cases, they hence observed a higher amount of this kind of disfluencies related to subjects than to direct objects. Unfortunately, they do not seem to consider the relative frequency of subjects and objects (pronouns or nominal): Almost all finite verbs have a subject, whereas only transitive verbs have an object, therefore the ratio cannot be compared directly.

(3.11) (Clark & Wasow 1998: 220)

yes, I {uh} I wouldn't be surprised at that

### 3.3.1.2 Processing difficulty for complex subjects

Clark & Wasow (1998: 213) do not only observe a higher proportion of repetitions in subjects, but also a higher proportion of repetition for complex NPs. They

### 3 Processing approaches

define complex NPs as NPs that contain material after the head noun. They found a ratio of 65 repetitions of the determiner *the* in complex subject NPs, against 55 repetitions of the same determiner in simple object NPs per 1,000 NPs (Clark & Wasow 1998: 213). Thus the impact of complexity seems even a bit stronger than the impact of the grammatical function mentioned above. Notice that the two factors do not appear to be superadditive<sup>6</sup>.

Kluender (2004) reports several pieces of evidence from various studies and authors that show that the complexity of the subject and the complexity of the rest of the VP are in competition in terms of processing. In spontaneous production, they tend to be in complementary distribution: the longer the subject, the shorter the VP and conversely. This is attested in English for children (corpus studies on early acquisition in Bloom 1990, 1993), for adults (diachronic corpus study of diaries in Kemper 1987) and for seniors (corpus study in Kynette & Kemper 1986). It has also been found in Italian for adults (Hyams & Wexler 1993: 440) and in Japanese for children and adults (Ueno & Polinsky 2009)<sup>7</sup>. The general observations are the following: (a) the longest VPs tend to have clitic subjects, (b) subjects are on average shorter than objects, (c) pro-drop (in pro-drop languages) is more frequent with transitive than intransitive verbs. Some experiments on processing by seniors in Kemper (1986) (repetition task) and Norman et al. (1992) (self-paced reading task) corroborate this: complex subjects are skipped in repetition tasks 92% of the time (only 11% for complex objects), and are read more slowly as well. Notice that the authors tested a wide variety of complex subjects (e.g. NP with a relative clause, sentential subjects). Based on these data, I expect that complex NPs with a PP-complement, which are often cited in the literature on subject islands, are less difficult to process than NPs with a relative clause complement, infinitival subjects or sentential subjects.

#### 3.3.1.3 Processing difficulty for verbal subjects

Lastly, Kluender (2004) mentions some processing difficulties inherently related to verbal subjects. Infinitival and sentential subjects are of course difficult to process for the same reason as any complex subject. Furthermore, following Kluender (2004: 106), comprehenders quickly forget the syntactic configuration of a clause when they reach its end. This, he claims, is what makes it difficult to process center-embedded sentences. It also explains the difficulty of extraction out

---

<sup>6</sup>Complexity: there are 30 repetitions in simple NPs and 55 repetitions in complex NPs. Function: there are 30 repetitions in objects and 45 repetitions in subjects. We would hence predict around 82.5 ( $55 \cdot 45 / 30$ ) repetitions for complex subject NPs, and Clark & Wasow find 65 repetitions. The observed results are therefore in the range of simple additive effects.

<sup>7</sup>Cited under a different title in Kluender (2004).

of an infinitival or sentential subject like in (3.12). This argument is somewhat similar to some syntactic approaches like Spell-out, but restricted to clauses.

(3.12) (Kluender 2004: 118)

- a. \* Who does [that she can bake ginger cookies for \_] give her great pleasure?
- b. ?? Who does [to be able to bake ginger cookies for \_] give her great pleasure?
- c. ? Who does [being able to bake ginger cookies for \_] give her great pleasure?

### 3.3.2 Valency Completeness

Hawkins proposes the Valency Completeness preference to account for extraction out of nominal, infinitival and sentential subjects:

(3.13) Valency Completeness:

The human processor prefers [Filler-Gap Domains] to include the subcategorizers for all phrases within the domain that contains the gap. (Hawkins 1999: 278)

The Filler-Gap Domain of the extraction out of the subject in (3.14a) is (3.14b). When the addressee reaches the gap, the structure (3.14b) includes the direct subcategorizer of the gap (*disliked*), but not the subcategorizer of the sentential subject (*surprise*). Hence, the addressee cannot know at this point the syntactic role of the clause in which the gap is located.

- (3.14) a. \* Who<sub>i</sub> did [that Mary disliked \_<sub>i</sub>] surprise Sue?  
 b. Who did that Mary disliked ...

Extraction out of nominal subjects has the same problem. This leads to additional processing difficulty when extracting out of subjects and explains the contrast with extraction out of objects.

The Valency Completeness preference predicts that extraction out of postverbal constituent should be more acceptable. Hence, extraction out of postverbal subjects should be as felicitous as extraction out of objects.

As a matter of fact, Kluender's and Hawkins's approach are not mutually exclusive. Several factors may have an impact on subextraction from subjects. Since superadditivity effects are caused by an accumulation of several factors, both proposals may bring us closer to understanding the processing of subject islands. We

### 3 Processing approaches

may even go so far as saying that these approaches are compatible with accounts based on dependency-length minimization, even though they make opposite predictions. Several processing preferences may be at play, especially in constructions as complex as filler-gap dependencies (this is actually the view defended by Hawkins 1999).

## 3.4 Definiteness, referentiality and specificity

In this section, I briefly address other semantic factors that have been known to influence extraction phenomena and have been linked to processing. I present the general discussion, and how these factors have been part of the discussion about subject islands.

The contrast between subextraction from an indefinite and from a definite NP has been well known since it was pointed out by Chomsky (1973) and Erteschik-Shir (1973). This phenomenon, illustrated by (3.15), is sometimes called the definite NP island.

(3.15) (Radford 2009)

- a. Who<sub>i</sub> were you reading a book about?
- b. \* Who<sub>i</sub> were you reading the/*this*/*that*/*his* book about?

For Ariel (1988), definite descriptions are cognitively less accessible than indefinite ones. The reason is that definite descriptions contain more information, which makes retrieving them more costly. Definite descriptions are stored in long-term memory, while indefinite ones are in short-term memory, ready to be retrieved as soon as necessary. Kluender (1998: 269) proposes to use this theory to account for the contrast in (3.15).

Subextraction from subject NPs is by definition impacted by this contrast. Extraction out of definite NP subjects is not necessarily ungrammatical, but extraction out of demonstrative NP subjects is less acceptable (Jiménez-Fernández 2009).

(3.16) (Jiménez-Fernández 2009: 117)

- a. ¿[De qué cantante]<sub>i</sub> has dicho que son muy provocativas  
of which singer have.2SG said that are very provocative  
[varias/las fotos <sub>-i</sub>]?  
several/the photos  
'Of which singer have you said that several/the photos are very  
provocative?'



- b. \* ¿[De qué cantante]<sub>i</sub> has dicho que son muy provocativas  
of which singer have.2SG said that are very provocative  
[estas fotos <sub>-i</sub>]?  
these photos  
‘Of which singer have you said that these photos are very  
provocative?’

Simonenko (2016) explains this by the semantic contradiction between the presupposition invoked by the demonstratives (they are deictic or anaphoric, hence their referent is known in the discourse situation) and the presupposition of questions (the *wh*-phrase refers to an unknown individual), (see also Erteschik-Shir 1973).

The research on islands also tends to emphasize the role played by fillers with high referentiality. The discussion mostly revolves around interrogatives in English. In English, the determiner *which* + N or *what* + N is used to build filler phrases that are more referential than, for example, *what*. The corresponding filler in French is *quel(le)(s)* + N (lit. ‘of which(.FEM.PL)’). The contrast between these fillers and other less referential ones, illustrated in (3.17), has long been under discussion, especially for extraction out of embedded questions (e.g. Pesetsky 1982, Kluender & Kutas 1993a,b, Erteschik-Shir 2006, Jiménez-Fernández 2009, Chaves 2013). This phenomenon is often referred to as “d(iscourse)-linking” in the literature, a denomination that goes back to Pesetsky (1982).

(3.17) (Erteschik-Shir 2006: 318)

- a. ? [Which book]<sub>i</sub> did you wonder [whether John bought <sub>-i</sub>]?  
b. ?? What<sub>i</sub> did you wonder [whether John bought <sub>-i</sub>]?

Many introspective and experimental data suggest that these referential fillers improve extraction, regardless of islandhood (Kluender & Kutas 1993a,b).

Referential fillers have also been addressed in the discussion on subject islands. Scholars observed that the acceptability of subextraction from subject improves with referential fillers.

(3.18) (Ross 1967: 242)

- [Of which cars]<sub>i</sub> were [the hoods <sub>-i</sub>] damaged by the explosion?

Jiménez-Fernández (2009) proposes a syntactic explanation of the phenomenon, and accommodates Chomsky’s (2008) analysis of subject islands based on phases. Jiménez-Fernández (2009) assumes that DPs are by default weak, but may

### 3 Processing approaches

become strong DPs if they are definite and “non-d-linked”. Strong DPs are then phases, and are therefore islands to extraction. Chaves (2013: 313) points out the weaknesses of this analysis, which is not independently motivated and circular. The general impression is that definite NPs with a non-specific element extracted are phases because extraction is prohibited, and as Chaves complains “the causal nexus between movement and D-linking remains obscure”.

Erteschik-Shir (2006) proposes an explanation at the interface between syntax and information structure. She redefines d-linking as a property of being referential that is inherent for *which* + N fillers, and can be attributed to other *wh*-words by the discourse context (if for example *what*, as in (3.19), has identified referents in the Common Ground).

(3.19) (Pesetsky 1987, from Bolinger 1978)

I know that we need to install transistor A, transistor B, and transistor C, and I know that these three holes are for transistors, but I’ll be damned if I can figure out from the instructions where what goes! .

In Erteschik-Shir’s (2006) analysis, these d-linked NPs are the topic of the interrogative. Consequently, strictly speaking, there would be no extraction, because the gap is not a trace but a silent anaphoric pronoun. Example (3.20) illustrates Erteschik-Shir’s proposal.

(3.20) (Erteschik-Shir 2006: 327)

[Which book<sub>*i*</sub>]<sub>*T*</sub> [did you choose  $\emptyset$ <sub>*i*</sub>]<sub>*F*</sub>?

However, observe example (3.21), in which extraction of the adverb out of the non-finite subject seems completely acceptable:

(3.21) (Grosu 1981: 72)

The “Hunan” restaurant is a place [where<sub>*i*</sub> [having dinner  $_{-i}$ ] promises to be most enjoyable].

The filler in (3.21) is neither d-linked nor referential, but we know that it refers to a location as soon as we encounter it. The filler *where* is more specific than an imprecise filler like *what*. First, it is harder to have a mental representation of the referent of *what*, which could be anything. Second, *where* is compatible with fewer potential semantic roles, and this helps the active gap search to postulate the adequate gap, which reduces filled-gap effects. This all contributes to making the processing of (3.21) easier.

The same is true for questions with *which* + N. In (3.17), *which book* is semantically more informative than *what* (Hofmeister et al. 2013, Chaves 2013).

## 4 Discourse-based approaches

It is time to address the last type of approach, the one that takes into account pragmatics and discourse. In this chapter I introduce the working hypothesis formulated with colleagues during the years of research that led to the writing of this book: the Focus-Background Conflict constraint. Thus this chapter focuses on aspects of information structure.

It is important to note, however, that there are also other pragmatic considerations at play. Constructions involving extractions are costly from a processing point of view, but they are used in order to fulfill specific communicative goals (which differ from one construction to another). If this were not the case, according to Grice's (1975) Cooperative Principle, the speaker would resort to a simpler construction. It is therefore essential that the use of extraction is relevant: this is the central idea of Chaves & Putnam (2020) who attribute the first formulation of it to Kuno (1987).

Kuno notices that the contrast in (4.22) cannot be attributed to a semantic distinction between the two verbs involved.

- (4.1) (Kuno 1987: 23)
- a. What did you see pictures of?
  - b. \* What did you see a book about?

The explanation, Kuno claims, relies on the fact that seeing a picture is necessarily synonymous with seeing what this picture portrays. For that reason, what the picture portrays is a relevant aspect of the event of seeing a picture. By contrast, seeing a book does not necessarily imply seeing what the book is about. Reading a text and seeing the physical object book are two distinct events. Consequently, it is not obvious that the theme of the book is relevant to the event of seeing a book. Because the theme of the book is not relevant, there is no compelling reason to ask questions about it. Hence, it is difficult for the addressee to imagine a context in which the question would be needed in the first place, and the sentence (4.1b) is perceived as unacceptable.

Chaves (2013) shows with numerous examples that extraction of non-relevant elements leads to an important degradation of the sentences. Example (4.2) is

#### 4 *Discourse-based approaches*

an extreme case. It is indeed very difficult to imagine a situation in which the ownership is at-issue in a sneezing event.

(4.2) (Chaves 2013: 12)

\* What<sub>i</sub> did [the owner of <sub>-i</sub>] sneeze?

Expanding on Kuno's (1976) idea, Chaves & Putnam (2020: 327) posit that the extracted element must be relevant to "the main action that the sentence describes".

It seems indisputable to me that this factor is highly pertinent. I refer the reader to Chaves & Putnam (2020) for a more exhaustive discussion. My own work, however, has addressed a discourse factor that is different from relevance, but which is not in contradiction with it. Before going into more detail about my working hypothesis, I need to define the concepts of information structure that I use in this book (Section 4.1), and then present previous works that have explored these notions in the context of islands.

### 4.1 Information structure

The discourse-based approach takes into account an undoubtedly crucial parameter in communication, a parameter so complex that it is very difficult to formalize it entirely: the fact that communication is an interchange of information between several participants in a discourse event. Phatic discourse, i.e. discourse in which no exchange of information is involved, is possible, but it is the exception rather than the rule. An interchange of information between several participants requires from each of them a capacity for what Kuno (1976) calls "empathy" (and which could also be labeled "Theory of Mind"): They need to recall which pieces of information the other participant(s) have and which ones they do not have. The sentence "*Mary is a good scholar.*" only succeeds in its informative role if all participants in the discourse know who Mary is (Kuno 1972: 309). In order for the communication to be efficient, it is also necessary that each participant keeps in mind the information that they have already been given in the previous part of the discourse.

In this work, we assume a formalization of how individual participants manage discourse information based on "information packaging" (Chafe 1976) and on the notion of Common Ground (Krifka 2007).<sup>1</sup> Common Ground covers information

---

<sup>1</sup>The notion of "Common Ground" was probably first discussed by Stalnaker under the notion of "common knowledge" and especially "common background knowledge" (Stalnaker 1978: 86).

exchanged in a particular discourse. The Cooperative Principle defined by Grice (1975) also implies that every utterance in a discourse entails a proposition which augments the Common Ground. For this reason, example (4.3b) is inappropriate in the specific discourse situation. The first utterance, *I had to bring my cat to the vet*, entails at least two pieces of information: the first one is presupposed and is that a cat exists and that the speaker is the owner of this cat; the second piece of information, *I have a cat*, brings no new information to the Common Ground, because the information that it entails is redundant to the information presupposed in the previous utterance. This is not the case with (4.3a), where each part of the sentence brings new information to the Common Ground.

- (4.3) a. I have a cat, and I had to bring my cat to the vet.  
 b. (Krifka 2007: 16)  
 # I had to bring my cat to the vet and I have a cat.

#### 4.1.1 Topic and comment

Reinhart (1982) proposes a helpful metaphor to describe the integration of new information in the Common Ground: we can imagine the information that conversation partners store as a collection of index cards. Each card has a title, its index: this is the topic. On each card, under the title, participants keep record of the relevant information: this is the comment, i.e. what the utterance states about the topic.

We use the subscript  $T$  and square brackets to identify the topic in our examples if needed. Similarly, we use the subscript  $C$  and square brackets to identify the comment.

For example, in (4.4), the first utterance introduces the individual Geneva to the Common Ground; this individual is then the topic of the second utterance. The comment is the information about her love for parrots.

- (4.4) This is Geneva Howell. [Geneva] $_T$  loves parrots.

Example (4.4) illustrates an *aboutness topic*. There is a second kind of topic, called *frame-setting topic* (Krifka 2007: 45–46). A frame-setting topic “acts as a restrictor as to when, where or with respect to who or what, the truth value of the predication is to be evaluated” (Erteschik-Shir 1997: 130). In example (4.5), the adverb is the topic and restricts the domain for which it is true that Peter is well (implicitly implying that Peter is not well regarding other domains of his life).

#### 4 Discourse-based approaches

- (4.5) (Jacobs 2001: 655)  
[Körperlich]<sub>T</sub> geht es Peter gut.  
physically goes it Peter well  
'Physically, Peter is well.'

As we will see, the aboutness topic will be the most relevant one in the study of subject islands. Very often, the aboutness topic of an utterance is anaphoric, hence uses “given” information. “Given” means here that it already entered the Common Ground at some point of the discourse. However, givenness is not required for topicalization: Corpus studies show that new information can become the topic of an utterance (Krifka 2007: 41–42).

- (4.6) a. (Krifka 2007: 42)  
[A good friend of mine]<sub>T</sub> [married Britney Spears last year]<sub>C</sub>.  
b. (Reinhart 1982: 66)  
Because they wanted to know more about the ocean’s current,  
[students in the science club at Mark Twain Junior High School of  
Coney Island]<sub>T</sub> gave ten bottles with return address cards inside to  
crewmen of one of New York City’s sludge barges.

Reinhart (1982: Section 3.2) proposes a way to test whether X is the aboutness topic of a given utterance by using a paraphrase such as “*as for X ...*”, “*speaking about X ...*”, or “*about X ...*”. If the paraphrase is pragmatically identical with the original utterance, then X is the aboutness topic. Based on this idea, Götze et al. propose the following test for aboutness topics:

- (4.7) An NP X is the aboutness topic of a sentence S containing X if: S would be the natural continuation of the announcement *Let me tell you something about X*. (Götze et al. 2007: 19)

Lastly, I should add that some sentences do not contain a topic. Topicless sentences are called *thetic sentences* (Kuroda 1976, Ladusaw 1994).

##### 4.1.2 Focus

The notion of “focus” is very common in linguistics and at the same time usually poorly defined. Different authors employ the term in different ways, without explicitly specifying which definition they are using. In this work I adopt the definition given by Alternative Semantics (Rooth 1992), which has the advantage of being a formal definition. In Alternative Semantics, focus signals the importance

of alternatives to the focused element for the interpretation of the utterance. For this reason, the most straightforward example of focus is an answer to a *wh*-question. An interrogative word like *which* in (4.8a) signals a set of alternatives (here the set of speaker B's siblings, let us assume the set {Jennifer, Karen, Brandon}). The focus of speaker B's answer in (4.8b) is the most informative element of the utterance (namely here the individual Karen).

- (4.8) a. Speaker A: Which one of your siblings is the oldest?  
 b. Speaker B: [Karen]<sub>F</sub> is the oldest.

We use the subscript <sub>F</sub> and square brackets to identify the focus in our examples if needed, as can be seen in (4.8b). All other elements of the utterance – i.e. *be the oldest* for (4.8b) – are backgrounded (see Section 4.1.3).

Any kind of constituent can be focused: a single word like in (4.8b), whole sentences like in (4.9b), as well as everything in between.<sup>2</sup>

- (4.9) a. Speaker A: What happened?  
 b. Speaker B: [Karen bought a parrot]<sub>F</sub>.

This leads to a distinction between narrow and broad focus based on the type of constituent being focused: the whole sentence (broad focus) or some constituent(s) (narrow focus).

Though other definitions have been proposed in previous literature, I will assume Götze et al.'s (2007) definition of focus:

- (4.10) Typically, focus on a subexpression indicates that it is selected from possible alternatives that are either implicit or given explicitly, whereas the background can be derived from the context of the utterance.

The focused element is also mostly the one bearing the main stress of the sentence (at least in languages like English or French). Krifka (2007) notes, however, that stress is only one possible way to signal focus, and not the very definition of focus. Prosody is at best a useful tool to identify certain kinds of focus. In the written language, however, we can only stipulate the place of the main stress. As the empirical part of this work is based almost exclusively on written French

<sup>2</sup>Even contrastive focus on one syllable is possible in order to stress metalinguistic information.

(i) I did not say that he had been a pathetic help, but that he had been a SYMpathetic help!

#### 4 *Discourse-based approaches*

(research in written corpus and experiments based on reading tasks), I will not say much about the intonational aspect of focus.

Focus is also sometimes described as the most “important” part of the utterance. Krifka (2007) criticizes this formulation for being vague and subjective. In his opinion, importance, as well as pertinence or main stress, only correlates with focus, but none of these aspects are criteria to define it.

Finally, it is also useful to say a word on the relation between focus and new information, or between focus and the topic/comment distinction. The focus, unlike the background as stated in definition (4.10), cannot be derived from the context of the utterance, it is new information. This does not mean, however, that the semantic referent has not been mentioned in the discourse, only that this part of the proposition is new. In (4.11), the answer selects one of the alternatives previously mentioned in the discourse. What is new is that the destination was the beach.

- (4.11) a. Speaker A: Did you go to the beach or to the museum yesterday?  
b. Speaker B: We went to the [beach]<sub>F</sub>.

In (4.12), the focus contains an anaphoric pronoun, i.e. the referent has already been mentioned, but it is still a felicitous answer to speaker A’s question, because it is selected from other possible alternative answers.

- (4.12) (Marandin et al. 2007)  
a. Speaker A: Who did Felix praise?  
b. Speaker B: Felix praised [himself]<sub>F</sub>.

Because of this, focus is often part of the comment, but contrastive, corrective or confirmative focus (see below) is also possible on the topic, which is then usually called a “contrastive topic”.

Many kinds of focus have been identified in the literature (Krifka 2007: 6–34). I will now define the kinds of focus which are useful in this work. This list is by no means exhaustive.

##### 4.1.2.1 **Information focus**

Information focus is the prototypical kind of focus, and is also called *semantic focus*. Informational focus occurs when new information is added to the Common Ground; it is the element that answers the implicit or explicit question.



## 4.1.2.2 Contrastive focus

An utterance containing a contrastive focus reacts to a proposition which just entered the Common Ground. The focus signals an element that the speaker wants to correct or wants to provide additional information on. One example of the latter is given in (4.13).

- (4.13) a. Speaker A: Karen has a child.  
 b. Speaker B: [Brandon]<sub>F</sub> has a child too.

## 4.1.2.3 Corrective (or confirmative) focus

An utterance with a corrective or confirmative focus also reacts to a proposition which just entered the Common Ground. In (4.14a), the focus element corrects the alternative previously mentioned in the discourse (here: Karen) and excludes it: this alternative makes the proposition false. In confirmative focus like (4.14b), the alternative previously mentioned in the discourse is pertinent, and other potential alternatives are excluded: the proposition with this alternative is true.

- (4.14) Speaker A: Karen is the oldest.  
 a. Speaker B: No, [Brandon]<sub>F</sub> is the oldest.  
 b. Speaker B: Yes, [Karen]<sub>F</sub> is the oldest.

## 4.1.2.4 A topic with focus properties: Contrastive topic

The answer in (4.15b) contains two topics: *Karen* and *Brandon*. Both are continuation topics that add more information to the topic introduced in the question (4.15a), *your siblings*. Since *siblings* refers to several individuals, there is potentially a need to distinguish between them.

- (4.15) a. Speaker A: What do your siblings do?  
 b. Speaker B: [Karen]<sub>CT</sub> is a writer and [Brandon]<sub>CT</sub> is a life guard.

In this case, we talk about contrastive topics (Krifka 2007: 44–45). Contrastive topics have some properties of focus, because they signal a set of sets of propositions (whereas focus signals a set of propositions).

### 4.1.3 Background (and presuppositional content)

The background – already defined in (4.10) – is the part of the utterance that is presupposed, following the definition of presupposition given by Lambrecht 1994.

- (4.16) A proposition P is a pragmatic presupposition of a speaker in a given context just in case the speaker assumes or believes that P, assumes or believes that his addressee assumes or believes that P, and assumes or believes that this addressee recognizes that he is making these assumptions, or has these beliefs. (Lambrecht 1994: 51)

Any information can be backgrounded because it is old information in the Common Ground, but it can also be new information that is not at issue and that must be taken for granted in order for the propositional content of the utterance to be true (Lambrecht 1994: 54). Focus and Background are in complementary distribution, such that an element in the utterance must be either focused or backgrounded.

In Alternative Semantics, the background is regarded as introducing a set of only one element.

Presuppositions differ from implicatures, because implicatures can be negated while the negation of a presupposition is infelicitous. Consider (4.17a), whose implicature is that the speaker has only one child. Yet, the conversation in (4.17b) is felicitous, even though this implicature is contradicted in the next sentence.

- (4.17) a. I have a child.  
b. Speaker A: I wish I were a father. What about you, do you have a child?  
Speaker B: Yes, I have a child. Actually, I have three children.

This contrasts with the presupposition of (4.18a), which is that Jennifer has two siblings (the verb *to know* takes as a complement an S whose propositional content is presupposed). Contradicting this presupposition as in (4.18b) is infelicitous.

- (4.18) a. The landlord does not know that Jennifer has two siblings.  
b. # The landlord does not know that Jennifer has two siblings.  
Actually, she's an only child.

This property of presuppositions led Erteschik-Shir (1973) to propose a test of backgroundedness, called the “liar test”. The test consists in reporting that

## 4.2 General principles: from Erteschik-Shir (1973) to Goldberg's BIC

someone has said the utterance, and then adding that this person was lying about a particular part of the utterance. Example (4.19) is a liar test for the utterance in (4.18a). The continuation in (4.19a) shows that the elements [*does not know*] are not backgrounded (they bear the informational focus), while the continuation in (4.19b) shows that the sentential complement [*Jennifer has two siblings*] is backgrounded.

- (4.19) Ash said: The landlord does not know that Jennifer has two siblings...
- a. ... which is a lie: he does know.
  - b. # ... which is a lie: she's an only child.

Lambrecht (1994: 51), Ambridge & Goldberg (2008) and Cuneo & Goldberg (2023) propose similar tests that take advantage of the same property of presupposition in order to identify the backgrounded elements. It must be noted that the liar test targets only the backgroundedness with respect to the main clause. The internal information structure of an embedded clause cannot be targeted directly; the embedded sentence has to be tested in isolation.

## 4.2 General principles: from Erteschik-Shir's dominance constraint on extraction to Goldberg's "Backgrounded Constituents are Islands"

In this section, I will present some accounts based on the discourse function of extractions that offer an analysis of many different islands. The next section will be devoted to the subject island in particular.

### 4.2.1 The Focus approach

Erteschik-Shir proposed another alternative to syntactic accounts of islands (Erteschik-Shir 1973, 1997, 2006). Her proposal is based on information structure<sup>3</sup> and maintains as a general principle that extraction can only occur out of the "potential focus domain". The focus domain consists of the focus and the elements it c-commands (including traces). In her early works, this concept was defined as the semantically dominant phrase or clause.<sup>4</sup> Her original constraint is reproduced in (4.20):

---

<sup>3</sup>Which she calls the f(ocus)-structure since Erteschik-Shir (1997).

<sup>4</sup>She defines "semantic dominance" as such: "A clause or phrase is semantically dominant if it is not presupposed and does not have contextual reference." (Erteschik-Shir 1973: 22). In later works (e.g. Erteschik-Shir 2006), she says that the two formulations are equivalent.

#### 4 Discourse-based approaches

- (4.20) The dominance condition on extraction (Erteschik-Shir 1973: 27):  
Extraction can occur only out of clauses or phrases which can be considered dominant in some context.

Erteschik-Shir uses the liar test in order to identify the potential focus domain in a specific context. Example (4.21) makes clear that the context is very important in determining the focus domain: in both examples, the liar test targets the complement of the noun in the NP [*a book about Nixon*]. However, the test shows that *about Nixon* is in the focus domain only in (4.21a), not in (4.21b).

- (4.21) a. Sam said: John wrote a book about Nixon. Which is a lie – it was about a rhinoceros.  
b. Sam said: John destroyed a book about Nixon. #Which is a lie – it was about a rhinoceros.

This distinction explains the contrast in (4.22): in (4.22a), the extracted element belongs to the potential focus domain, and can therefore be extracted following (4.20), whereas in (4.22b), it does not.

- (4.22) (Bach & Horn 1976: 272)  
a. What did they write a book about?  
b. \*What did they destroy a book about?

Context also plays a role in the fact that acceptability varies for islands: “the positive response of informants is conditional on their ability to contextualize in such a way that the clause from which extraction has occurred is interpreted as a focus domain” (Erteschik-Shir 2006: 320).

#### 4.2.2 The Topic approach

In contrast to Erteschik-Shir, Kuno (1987) proposes an account of islands based on Topic. He notices that Erteschik-Shir’s proposal is not able to account for the contrast between (4.23a) and (4.23b). The context remains the same (hence with the same potential focus domain), and the liar test gives similar results but extracting *the actress* out of the NP [*Mary’s portrait of this actress*] is not felicitous. The reason cannot be the presence of the genitive *Mary’s* alone, because the extraction in (4.23c) is felicitous.

(4.23) (Kuno 1987: 13)

- a. Yesterday, I met the actress who I had bought a portrait of.
- b. \* Yesterday, I met the actress who I had bought Mary's portrait of.
- c. This is the story that I haven't been able to get Mary's version of.

Kuno's (1987) proposal is that topics, and not dominant (or focused) elements, are extracted. His definition of topichood is somewhat broader than the one I gave previously, because in his proposal not only utterances but NPs can have a topic as well. The utterance (4.23c) implies that the speaker has heard the version of this story from at least one other person. It thus opens an alternative set: *Mary's* is interpreted as contrastive, and therefore as focus. *The actress* can be interpreted as the topic of the NP in (4.23a), while in (4.23b) *Mary* is more naturally the topic, and *the actress* the focus in the NP. Kuno formulates this constraint as follows:

(4.24) Topichood Condition for Extraction (Kuno 1987: 23):

Only those constituents in a sentence that qualify as the topic of the sentence can undergo extraction processes (i.e. Wh-Q Movement, Wh-Relative Movement, Topicalization, and It-Clefting).

### 4.2.3 The salience approach (reconciling the Focus and Topic approaches)

The Focus approach and the Topic approach are not mutually exclusive, and Kuno (1987) sees the Topic Condition as an extension of Erteschik-Shir's rule. What is missing in both accounts, however, is an explanation of how a syntactic factor like extraction and discursive factors like topic and focus interact.

Deane (1991) answers this concern and provides a unifying account based on the management of cognitive resources. He suggests that extraction requires simultaneous consideration of two separate parts, the filler and its head, which we need to link together in order to obtain the appropriate syntactic structure. The longer the distance, the stronger this division of attention taxes our cognitive resources: we have limited space in our short-term memory. If the two parts are cognitively salient, however, it is easier to keep them active. Focus and topic are the two most salient elements in the sentence: the focus is salient because it is the important part of the discourse, and the topic is salient because it is the center of interest in the sentence. They are therefore the best candidates for extraction.

Building on this idea, and adopting the constraint-based counterpart of Erteschik-Shir (1973) dominance condition on extraction, Goldberg proposed the BCI constraint (see also Ambridge & Goldberg 2008, Goldberg 2013, Cuneo & Goldberg 2023):

- (4.25) Backgrounded constructions are islands (BCI) (Cuneo & Goldberg 2023: 2):  
Constructions are islands to long-distance dependency constructions to the extent that their content is backgrounded within the domain of the long-distance dependency construction.

The BIC and the dominance condition on extraction make the same predictions: extraction out of non-focus (hence backgrounded) constituents is infelicitous. Both constraints are discourse-based, but this is not reflected explicitly by their respective formulation.

### 4.3 The subject island constraint from a functional perspective

Erteschik-Shir (1973) shows that sentential subjects are presupposed in the utterance. Consider first the sentential complement in (4.26):

- (4.26) (Erteschik-Shir 1973: 157)  
Bill said ‘It’s likely that Sheila knew all along.’  
a. , which is a lie – it isn’t.  
b. , which is a lie – she didn’t.

Targeting the sentential complement with the liar test seems to be felicitous. We can conclude that the it is not backgrounded, hence part of the potential focus domain. This clearly contrasts with the sentential subject in (4.27).

- (4.27) (Erteschik-Shir 1973: 157)  
Bill said ‘That Sheila knew all along is likely.’  
a. , which is a lie – it isn’t.  
b. \*, which is a lie – she didn’t.

Most scholars in the functional approach agree that the “subject island constraint” for an NP subject is caused by the subject being the default topic of the utterance. One piece of evidence is that topics have a preference for being expressed as subjects. Indeed, when *John* is the topic, the answer in (4.28a) is more natural than the one in (4.28b).

#### 4.4 The BCI revisited: the Focus-Background Conflict constraint

- (4.28) (Erteschik-Shir 2006: 323)  
Tell me about John.  
a. – He is in love with Mary.  
b. – Mary is in love with him.

This is not to say that subjects are always topics. We can see a counterexample in (4.29a). Here, the subject is more likely to be the new or unpredicted information in the sentence, and thus the focus, which is why (4.29b) is a good paraphrase for it.

- (4.29) (Kuno 1987)  
a. [This person alone]<sub>F</sub> [passed the test]<sub>B</sub>.  
b. The only person who passed the test was this person.

Erteschik-Shir (2006: 324) assumes that extraction is allowed only in what she calls “canonical f-structures”, in which the subject is the topic (see also Erteschik-Shir 1997: 186). The reason is that it is harder for the addressee to identify the dependents in an utterance with a non-canonical f-structure like (4.29a), and it is therefore harder to identify the gap. Because extraction has to take place from the potential focus domain, as stated in (4.20), extraction out of subjects is ruled out.

As could be expected, Goldberg (2006) makes a similar proposal. With subjects being default topics – what she calls “primary topics” –, and topics being backgrounded, extraction out of the subject violates the BCI (4.25). It is possible to extract a primary topic as a whole, but not part of it. She explains: “It is pragmatically anomalous to treat an element as at once backgrounded and discourse-prominent.” Hence, according to Goldberg, the subject island is caused by a discourse clash.

#### 4.4 The BCI revisited: the Focus-Background Conflict constraint

The previous functional approaches to islands did not pay much attention to the fact that not all filler-gap dependencies have the same discourse function. Indeed, *wh*-questions and *it*-clefts focus the extracted element (Lambrecht 1994), while relativization and topicalization topicalize it (Kuno 1987: 15).<sup>5</sup> Even though

---

<sup>5</sup>The idea that the relationship is a topic-comment relationship is not new; it was probably first proposed by Kuno (1973) for Japanese (see also the Thematic Constraint on Relative Clauses

#### 4 Discourse-based approaches

Erteschik-Shir, Kuno and Goldberg explain constraints on extractions in terms of discourse status, they all take for granted that “topicalization processes (Topicalization and Relativization) and focusing processes (Wh-Q Movement and It-Clefting) are subject to the same constraint” (Kuno 1987: 27). Probably for the same reason, the constraints they proposed (Subject Condition, BCI, Topichood Condition for Extraction) rely on discursive factors, but are not explained in terms of discursive mechanisms.

Notably, these proposals all assume that extraction is a key factor in the constraint. But extraction, and word order more generally, is only one of many tools used in human languages to encode specific discourse status. There is no reason to believe that discourse clash cannot lead to infelicitous sentences independently of extraction. There are actually several examples of subject/object asymmetries present in *wh*-questions and not in relative clauses: in Kihung’an Takizala (1973), in Chicheŵa (Bresnan & Mchombo 1987), in Kaqchikel Mayan (Heaton et al. 2016) or in Tagalog Pizarro-Guevara & Wagers (2020). For example, in Chicheŵa (a language from the Bantu family), in which object marking (OM) on the verb is otherwise optional, the presence of an object marker is ruled out for object interrogatives. This is illustrated by the contrast in (4.30).

- (4.30) (Bresnan & Mchombo 1987: 759–760)
- a. Mu-ku-fún-á            chiyâni?  
   you-PRES-want-INDIC what  
   ‘What do you want?’
  - b. \* Mu-ku-chí-fún-á        chiyâni?  
   you-PRES-OM-want-INDIC what  
   ‘What do you want?’

In (4.30b), the verbal object marker *-chí-* seems incompatible with the object interrogative word *chiyâni*. According to Bresnan & Mchombo (1987: 758–760), the reason is that the verbal object marker *-chí-* is an anaphoric pronoun that signals that the object is the topic. Since the object cannot be topic and focus of the utterance at the same time, the sentence is ruled out.

---

by Kuno 1976: 420): “On the basis of the pervasive parallelism between topicalization and relativization, I proposed that in Japanese what is relativized is the theme of the relative clause.” (Kuno 1987: 15). Schachter (1973: 25) provides evidence from Ilonggo based on case marking that supports this claim. Several authors assume that the topic-comment relationship applies to English relative clauses as well (Gundel 1974; Gundel 1988: 79; Kuno 1987: 15). In general, many assume that it is a universal property of relative clauses (even though Lambrecht (1994) suggests that it may only be true for languages with post-antecedent relative clauses like French or English).



#### 4.4 The BCI revisited: the Focus-Background Conflict constraint

Because the topic designates what is under discussion (whether previously mentioned or assumed in discourse), it is presupposed. The interrogative focus designates what is NOT presupposed as known, and is contrasted with presupposed material. Hence, allowing the same constituent to be both topic and focus of the same clause leads to inconsistent presupposition. (Bresnan & Mchombo 1987: 758)

Extraction here plays no role, because the interrogative word is *in situ*.

Furthermore, as already discussed in Section 3.1, the contrast between the subject island on the one hand and the greater preference for subject relatives over object relatives on the other hand is very surprising and remains unexplained under the previous discourse-based accounts. The subject island seems to directly contradict Keenan & Comrie's (1977) Accessibility hierarchy.

Based on experimental data from English and French, we proposed in Abeillé et al. (2020: rule (8)) that the penalty observed in extraction out of the subject known as "subject island" is caused by a discourse clash: the degradation results from the attempt to focalize some part of a backgrounded element. Indeed, it seems reasonable to assume that we cannot simultaneously identify an individual *x* as part of the Common Ground and open a set of alternatives about some property inherent to this same individual. We therefore reformulated the BCI and call this the Focus-Background Conflict constraint, which we define as:

(4.31) Focus-background conflict (FBC) constraint:

A focused element should not be part of a backgrounded constituent.

We agree with previous discourse-based approaches in assuming that subjects are default topics (and thus backgrounded). Subextraction out of the subject that leads to focalization of the extracted phrase thus violates the FBC constraint, and this, we claim, is why it is degraded compared to a similar subextraction out of the object. Complements have a tendency to belong to the focus, and for this reason subextraction out of the object is more often felicitous.

Notice that this constraint explicitly presents focusing processes as the cause of the degradation. The straightforward consequence is that only focusing extractions like *wh*-questions and *it*-clefts can violate the FBC constraint. In a relative clause, the extraction is topicalization: the referent denoted by the antecedent of the relative clause (the noun modified by the relative clause) is the topic of the relative clause. In other words, the relative clause "is about" the noun it modifies. The subject in relative clauses is preferably backgrounded, but since the extracted element is not focused, the FBC constraint is not violated.

#### 4 *Discourse-based approaches*

The scope of the FBC constraint (4.31) extends beyond extraction. Focalization of part of a backgrounded constituent that does not involve extraction would violate the FBC constraint as well.

Moreover, the FBC constraint (4.31) is not expected to apply to all subjects. Even though subjects are topics by default, they may also be focus. This means that extraction out of a focus subject by means of an interrogative or *it*-cleft should be possible, because this does not lead to a discourse clash.

## 5 Concluding remarks on the state of the art

In this first part of the book, I presented three main approaches to the subject island phenomenon, and to the contrast between (some?) extractions out of the subject and extractions out of the object. The traditional and still most well-known approach is a syntactic approach. I have outlined different syntactic accounts that provide slightly different predictions, especially about whether extractions out of subjects of passives fall under the subject island constraint or not, and why some languages do not display a subject island effect. I also showed that all syntactic accounts predict that French is not an exception to the subject island constraint and that extraction out of the subject is ruled out. Relative clauses with *dont* may be an exception, according to Tellier (1990, 1991). In the following parts, I will simply use “syntactic accounts” as an umbrella term to refer to accounts that predict an important degradation when extracting out of subjects: extraction out of the subject is not part of the grammar of French.

There are a number of non-syntactic proposals concerning the subject island phenomenon. I presented accounts based on processing and on information structure. I identified two main trends in processing-based accounts. Looking at extraction from the point of view of memory load, shorter dependencies should be easier to process and extraction out of the subject is actually expected to be better than extraction out of the object. This is predicted by the DLT, and, to some extent, can be derived from Dependency Grammar. Another possible approach is to say that extractions out of the subject are unexpected (because subjects are complex or because there is not enough information yet when the addressee reaches the gap inside the subject) and therefore are surprising for the reader or hearer. Such surprisal-based accounts predict a degradation when extracting out of subjects. The degradation is not necessarily large, because other factors may counterbalance the effect of surprisal and ameliorate the processing difficulties caused by these subextractions.

Finally, I made a distinction between two main trends in discourse-based accounts. Previous discourse-based accounts predict a degradation when extracting out of subjects, regardless of the extraction type. As in processing-based ac-

## *5 Concluding remarks on the state of the art*

counts, the impact is not necessarily big. The problem with subextraction from subjects is caused by the difficulty to imagine a context in which the extraction would be felicitous, and this means that an appropriate context can improve the acceptability of the utterance. The FBC constraint that I put forth here is different. It states that the degradation in extraction out of subjects is caused by a discourse clash, but predicts extraction out of the subject to be acceptable in topicalizing constructions (e.g., relative clauses).

Many of these accounts are mutually exclusive, but not all are. Processing-based accounts and discourse-based accounts can be compatible with each other. I will argue in this book that the FBC can best account for the data that I present, in particular for the cross-construction contrast that I found. But the FBC constraint is compatible with accounts based on relevance because being relevant or at-issue is certainly necessary in order to create a context that supports the focalization or topicalization of some phrase. The FBC constraint is also compatible with accounts based on memory load, and whenever there is no violation of the constraint, a preference for shorter dependencies is expected. I also posit that the complexity of subjects plays a role, but that this factor has a smaller impact than has been claimed by Kluender (2004).

## **Part II**

# **Empirical studies on subextraction of subjects in French**



## 6 Preliminary remarks on the empirical data

It is impossible to design any meaningful theory (about the subject island, any other kind of island or any linguistic phenomenon in general) without agreeing on the data in the first place. But as far as extraction out of the subject is concerned, scholars do not agree on the acceptability status of many examples. For example: Is extraction out of the subject of passives acceptable or not? Is extraction out of the subject with *dont* in French better than extraction out of the subject with *de qui*? In the former case, different authors have given different judgements on the same language. In the latter case, Godard's (1992) intuition, as well as my own, differs from Tellier's (1990). This disagreement between linguists, even between native speakers, is far from exceptional. Experimental data have shown for a long time that native speakers disagree on such matters as soon as a sentence structure is complex, or the situation it describes infrequent (Chaves & Dery 2019). Obviously, filler-gap dependencies are a complex phenomenon in themselves and, unsurprisingly, not all speakers feel equally comfortable with all of them. Often enough, the constructed examples are also at least slightly (and sometimes very) unnatural, and the appropriate context is missing (see discussion in Section 4). Furthermore, linguists are not naive speakers on metalinguistic questions, and a linguist's intuition (including mine), albeit highly valuable, may be biased.

Quantitative data are by nature more resistant to individual preferences. Provided that we have a sufficient amount of data and that we treat outliers as needed, individual preferences disappear in the statistical result. What remains are general tendencies. For this reason, nowadays quantitative investigations play an important role in the linguistic debate. There are several ways to collect quantitative data, and in this work, I will use two methods that I judge equally important: corpus studies and experiments.

Islands in the languages of the world have been the focus of many experimental studies, probably starting with Kluender (1991). His work itself was the logical extension of the first online experiments on filler-gap dependencies that took place in the 80s (a.o. Tanenhaus et al. 1985, Stowe 1986). Since then there

have been a number of experiments on islands. In Chapter 7, I will present some experiments on subject islands in particular, a list that is necessarily by no means exhaustive. At the same time, there was little corpus investigation on the subject before our own work (Abeillé et al. 2016, Abeillé & Winckel 2020), except for Candito & Seddah (2012a) which I will mention below, but which deals with subextractions from the subject only incidentally. It is thus puzzling that extraction out of the subject were considered impossible without even considering whether speakers produced it.

Corpus data are productions with non-metalinguistic aims, it is therefore useful to look at them before constructed experimental items. The experimental items should describe familiar situations and an appropriate context should be easy to imagine. It is thus important to look at spontaneous productions of native speakers in order to know how filler-gap dependencies are actually used by speakers, what kind of situations are described and what kind of vocabulary is used.

Here, we should also pay attention to the relative frequencies of different structures based on different factors, especially the relative frequencies of extractions out of subjects and out of objects. My expectations are as follows:

1. If extraction out of subjects is indeed grammatically ruled out, then it should be absent from the corpora (or be accidental – I come back to this issue later on). Notice that the opposite is not necessarily true: the fact that a certain structure does not appear in a corpus does not imply nor prove that this structure is absent from the specific language, let alone that it is ruled out by syntax. No corpus, however large it might be, can be expected to include all possible structures of a certain language.
2. If extraction out of the subject is not ruled out, but only more difficult to process than extraction out of the object, then we expect the former to be less frequent in the corpora than the latter. Several previous corpus studies have shown that complex subjects are less frequent than complex objects. Kluender (2004), among various other scholars, argues that it is because they are harder to process (see Section 3.3.1). Extraction out of subjects, per definition, requires complex subjects to begin with, and should consequently be less frequent than extraction out of objects.
3. The Focus-Background Conflict constraint (4.31) predicts different results for different constructions. Because subjects are usually topics, focalization of a subpart of the subject should be dispreferred. For this reason,



extraction out of subjects should be less frequent in interrogatives and *c'est*-clefts. In these constructions, we also predict that the subjects which allow for subextraction can be interpreted as focus (e.g. with a contrastive meaning). In relative clauses, there is no constraint on the subextraction from subject: we expect to see different distributions between the different constructions.

As the corpus data cannot provide negative evidence, it is essential to conduct controlled experiments as well. If subextractions from subjects are not found in the corpora, we would need to verify that the speakers do not accept them. Without this proof, their absence in the corpora may be coincidental. Moreover, as we shall see, some constructions (*c'est* clefts and infinitival subjects) are too infrequent to allow a relevant statistical analysis in our corpus studies. Experimental data can provide us with more information on these constructions.

Since early experimental work on islands by Kluender & Kutas (1993a,b) and then by Sprouse and his colleagues (e.g. Sprouse et al. 2011, 2012, 2016, Sprouse & Almeida 2017), it has become common practice to use factorial designs in order to test island hypotheses, and to expect superadditive effects as a result of island constraints. The factorial design is usually a 2\*2 design, with a double comparison. The first comparison is between gap sites, comparing the “island” gap site with another gap site, similar but not expected to be an island for extraction. For example, the comparison often used in the literature on subject islands is between extraction out of NP subjects versus extraction out of NP objects. The second comparison is between two maximally similar constructions, one expected to create the island under investigation, and the other not expected to do so. For example, we can compare extraction of the whole NP with subextraction out of the NP, or – as we often did in the experiments that I will present – non-extraction with subextraction.<sup>1</sup> This double comparison ensures that we isolate the factor leading to the “island effect”, ensuring that it does not come from the gap site independently of the extraction type, or from the extraction type independently of the gap site. Island phenomena are expected to cause a superadditive effect, i.e. a statistically significant interaction effect between gap site and extraction type. If subjects are islands, the difference between extraction out of the object and extraction out of the subject is expected to be greater than between the two control

---

<sup>1</sup>We favor non-extraction instead of extraction of the whole NP, because there is a well-known preference in processing (and acceptability judgments) for subject relative clauses over object relative clauses (a.o. Wanner & Maratsos 1978, Traxler et al. 2002, Pozniak & Hemforth 2015). This preference can create interaction effects in the factorial design, that would not be related to the island phenomenon.

## 6 Preliminary remarks on the empirical data

conditions (e.g. extraction of the object and extraction of the subject). Figure 6.1 illustrates the expected difference between a linear additivity and superadditivity.

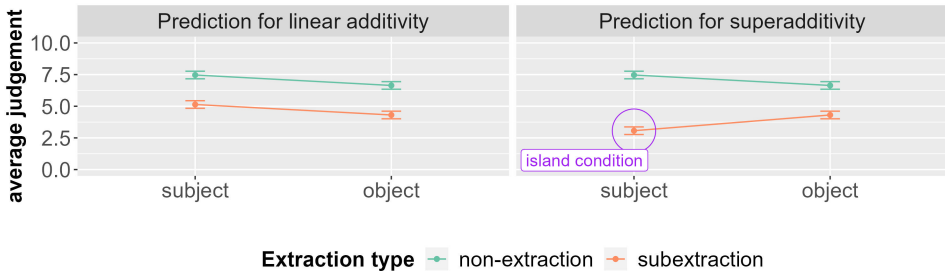

Figure 6.1: Prediction for linear additivity vs. superadditivity (inspired by Sprouse et al. 2012: 86). Extraction out of the subject (subject + subextraction) is the island condition.

I will present a series of 16 experiments, most of which follow a 2\*3 factorial design. In addition to the usual 2\*2 design, there is indeed a comparison between the subextraction condition and two ungrammatical controls.

In this work, I test the expectations of the various linguistic accounts of subject islands. As it is not possible to take them all into account, I identify five general categories of accounts: (i) “traditional” syntactic accounts (syntactic island hypothesis), (ii) processing accounts based on the hypothesis that complex subjects are unexpected, (iii) functional accounts based on the hypothesis that backgrounded constituents are islands to extraction, (iv) processing accounts based on the hypothesis that the distance between dependents should be as short as possible, and (v) functional accounts based on the hypothesis that focalizing a part of a backgrounded constituent results in a discourse clash. There are of course many variations within these categories, especially among the proponents of a syntactic account of subject island, as laid out in Section 2. However, they give rise to similar general expectations with respect to the experiments I will present. In a nutshell, we can say that accounts in the categories (i), (ii) and (iii) predict superadditive effects such that extractions out of the subjects are less acceptable (for offline experiments) or read more slowly (for online experiments) than the other grammatical conditions. By contrast, accounts from category (iv) predict an advantage for extractions out of the subject. Under the Focus-Background Conflict constraint, in category (v), superadditive effects with extraction out of the subject should only occur in focalizing constructions.

The quantitative analyses reported in this work were conducted in R (R Core Team 2018: version 3.6.3), and graphs are all created using the `ggplot2` package

(Wickham 2016). According to the broad consensus in statistics, I consider a result significant if and only if the confidence level is at least 95%, i.e. if and only if the probability value (*p* value) is at most 5% ( $p < 0.05$ ). I indicate the *p* value relative to six levels of significance:  $p < 0.05$ ,  $p < 0.01$ ,  $p < 0.005$ ,  $p < 0.001$ ,  $p < 0.0005$  or  $p < 0.0001$ .

The data and R code of all the corpus studies and experiments presented below are available online at <https://osf.io/5qhxa/>.



## 7 Previous experimental work on subextraction from subjects

In this chapter, I attempt to give an overview of the previous work on subject islands, reporting the results that I judged most interesting. I only mention experiments published in peer-reviewed publications or in Ph.D. theses and leave aside unpublished conference talks and posters. Nevertheless, given the growing interest of experimental linguistics in islands, the following is likely to be incomplete.

The experiments on French presented in this book, some of which have been published, are not included in this chapter, nor are a few experiments on English that we carried out in parallel with the French ones (Abeillé & Winckel 2019, Abeillé et al. 2020). They will be taken up later in the book.

I deliberately leave aside the work done by several scholars on a phenomenon called “satiation” or “habituation”. Sprouse (2007a,b, 2009), Francom (2011), Goodall (2011), Chaves & Dery (2014, 2019) and Chaves & Putnam (2020) investigated whether the acceptability of subject islands increases after repeated exposure. All these experiments examined extraction out of subjects in *wh*-questions. The subjects are NP subjects as well as non-finite and finite sentential subjects. The results are mixed, but the latest evidence suggests that the acceptability of extraction out of subjects improves after at least eight exposures.

I also omit studies on non-native speakers because the research questions they target are very different from my own. Kush & Dahl (2022) provide a current overview of the state of the art.

I start with studies on extractions out of NP subjects, which are the most common ones, before presenting studies on extractions out of sentential subjects.

### 7.1 Interrogatives

Unsurprisingly, the most studied language in these studies is English. Maybe more surprisingly, a large majority of the investigations concentrate on extraction in *wh*-questions (mostly direct *wh*-interrogatives, sometimes also indirect ones). An overview of these studies is found in Table 7.1.

## 7 Previous experimental work on subextraction from subjects

Table 7.1: Studies on English *wh*-questions

Publication	Subject type	Filler (island condition)	Task	Design	Results
Phillips (2006), Experiment 1	NP	Direct object (of the complement / of the relative clause)	Acceptability ratings, Likert scale	Tested embedded <i>wh</i> -question, crossing extractee type (direct object/complement of the subject NP/both) with finiteness (non-finite complement of NP/finite relative clause of NP).	<ul style="list-style-type: none"> <li>- interaction extractee type:finiteness (<math>p &lt; 0.0001</math>)</li> <li>- no effect of finiteness for direct objects</li> <li>- extraction out of the subject rated higher in the non-finite condition (<math>p &lt; 0.05</math>)</li> <li>- double gap rated higher in the non-finite condition (<math>p &lt; 0.0001</math>)</li> </ul>
Phillips (2006), Experiment 2	NP		Self-paced reading	Tested embedded <i>wh</i> -questions, crossing plausibility (filler is plausible as subject complement/implausible as subject complement) and finiteness (non-finite complement of subject/finite relative clause of subject).	<p>Accuracy on comprehension questions:</p> <ul style="list-style-type: none"> <li>- no interaction</li> </ul> <p>Reading times:</p> <ul style="list-style-type: none"> <li>- (marginal) interaction plausibility:finiteness (<math>p &lt; 0.05</math> in the participant analysis : <math>p = 0.086</math> in the item analysis), in that reading times increase only in the implausible + non-finite condition.</li> </ul>
Sproue (2007a), Experiment in section 3.2	NP	PP-complement (with preposition stranding)	Acceptability ratings, magnitude estimation	Crossing function (subject/object), extraction type (extraction of NP/extraction out of NP) and context (with/without supporting context).	<ul style="list-style-type: none"> <li>- interaction function:extraction type (<math>p &lt; 0.001</math>;</li> <li>- Cohen's <math>d = .521</math>)</li> <li>- no main effect of context</li> <li>- no 3-way interaction</li> </ul>
Jurka (2010), Experiment 8	NP	Of-complement (with and without preposition stranding)	Acceptability ratings, Likert scale	Crossing function (subject/object), extraction type (no extraction/extraction out of the NP) and preposition stranding (with/without preposition stranding).	<ul style="list-style-type: none"> <li>- for preposition stranding, interaction function: extraction type, in that extraction out of the subject is rated lowest</li> <li>- without preposition stranding, interaction function: extraction type, in that extraction out of the subject is rated lowest</li> <li>- interaction for preposition stranding larger than without preposition stranding</li> </ul>
Jurka (2010), Experiment 9	NP	Of-complement (with preposition stranding)	Acceptability ratings, Likert scale	Crossing extraction type (no extraction/extraction out of the subject) and Exceptional Case Marking (simple verb/embedding with ECM).	<ul style="list-style-type: none"> <li>- interaction extraction type:ECM, mostly due to the condition ECM with no extraction being much lower than ECM with subextraction</li> <li>- for extraction out of the subject, the simple verb is rated higher than the ECM (<math>p = 0.031</math>)</li> </ul>
Jurka (2010), Experiment 10	NP	Of-complement (with preposition stranding)	Acceptability ratings, Likert scale	Tested embedded <i>wh</i> -questions, crossing extraction type (no extraction/extraction out of the subject) and verb type (unergative/passive).	<ul style="list-style-type: none"> <li>- interaction extraction type:verb type, in that the extraction out of the subject of the unergative verb is rated lowest, but the effect size is very small</li> </ul>

## 7.1 Interrogatives

Sprouse et al. (2012), Experiment 1	NP	PP-complement (with preposition stranding)	Acceptability ratings, Likert scale + Serial recall task	Crossing function (subject/object) and extraction type (extraction of NP/extraction out of NP). A measure of working memory is also included.	- interaction function:extraction type ( $p < 0.0001$ ) - main effect of serial recall ( $p < 0.02$ )
Sprouse et al. (2012), Experiment 2	NP	PP-complement (with preposition stranding)	Acceptability ratings, magnitude estimation + Serial recall task and n-back task	Crossing function (subject/object) and extraction type (extraction of NP/extraction out of NP). Two measures of working memory are also included.	- interaction function:extraction type ( $p < 0.0001$ ) - no effect of serial recall ( $p = 0.7$ ) - no effect of n-back ( $p = 0.66$ )
Fukuda et al. (2012), Experiment 1	NP	Of-complement (with preposition stranding)	Acceptability ratings, yes/no	Crossing extraction type (no extraction/extraction out of NP) and extraction site (nominal subject/nominal object/wh-subject).	- interaction extraction type:extraction site ( $p = 0.0218$ ) - extraction out of nominal object rated higher than extraction out of nominal subject ( $p = 0.0052$ ) - extraction out of nominal object rated higher than extraction out of wh-subject ( $p < 0.001$ ) - no difference in rating between extraction out of nominal subject and extraction out of wh-subject ( $p = 0.997$ )
Fukuda et al. (2012), Experiment 2	NP	Of-complement (with preposition stranding)	Acceptability ratings, Likert scale	Same as previous	- interaction extraction type:extraction site ( $p = 0.0027$ ) - extraction out of nominal object rated higher than extraction out of nominal subject ( $p = 0.0001$ ) - extraction out of nominal object rated higher than extraction out of wh-subject ( $p = 0.0001$ ) - no difference in rating between extraction out of nominal subject and extraction out of wh-subject ( $p = 0.7504$ )
Fukuda et al. (2012), Experiment 3	NP	Of-complement (with preposition stranding)	Acceptability ratings, magnitude estimation	Same as previous	- marginal interaction extraction type:extraction site ( $p = 0.0582$ ) - extraction out of nominal object rated higher than extraction out of nominal subject ( $p = 0.0036$ ) - extraction out of nominal object rated higher than extraction out of wh-subject ( $p = 0.0001$ ) - no difference in rating between extraction out of nominal subject and extraction out of wh-subject ( $p = 0.2554$ )

## 7 Previous experimental work on subextraction from subjects

Polinsky et al. (2013), Experiment 1a	NP	Of-complement (with preposition stranding)	Acceptability ratings, Likert scale	Tested embedded <i>wh</i> -questions, crossing extraction type (extraction of the subject/extraction out of the subject) and verb type (unaccusative/unergative/transitive).	- marginal effect of verb type, only between unaccusatives and unergatives ( $p < 0.1$ ) - no interaction effect
Polinsky et al. (2013), Experiment 1b	NP	Of-complement (with preposition stranding)	Self-paced reading	Same as previous	- the verb and the NP following the verb are read slower with transitives than the other verb types ( $p < 0.05$ ) - the PP following the verb is read slower with unergatives than with unaccusatives ( $p < 0.005$ ) - the NP/PP following the verb is read slower in the subextraction than in the extraction ( $p < 0.0001$ )
Bianchi & Chesi (2015)	NP	Of-complement (with and without preposition stranding)	Acceptability ratings, continuous scale	Crossing predicate (stage-level/individual-level) and extraction type (with/without preposition stranding)	- interaction predicate-extraction type ( $p = 0.036$ ) - for 5-level predicates, preposition stranding is rated lower ( $p = 6.127 \times 10^{-15}$ ) - for 1-level predicates, preposition stranding is rated lower ( $p = 2.719 \times 10^{-5}$ )
Sprouse et al. (2016), English Experiment 2	NP	PP-complement (with preposition stranding)	Acceptability ratings, Likert scale	Crossing function (subject/object) and extraction type (extraction of NP/subextraction from NP)	- marginal interaction ( $p < 0.062$ )
Chaves & Dery (2019), Experiment 4	NP		Self-paced reading	Compared plausibility (filler is plausible/implausible as direct object of the relative clause inside the subject)	- reading times increase for implausible fillers on the verb of the relative clause
Chaves & Putnam (2020), Experiment 6	NP	Of-complement (with preposition stranding)	Acceptability ratings, Likert scale	Compared relevance (the extracted element is relevant / less relevant for the situation described by the sentence). The relevance scores are based on a previous norming experiment.	- more relevant fillers rated higher than less relevant fillers ( $p = 0.02$ )



Most studies on English *wh*-questions employ acceptability rating tasks with slightly different methodologies, whose results tend to be roughly similar (Fukuda et al. 2012). The “subject island effects” are attested and seem robust (Sprouse 2007a, Jurka 2010, Sprouse et al. 2012, Fukuda et al. 2012, Sprouse et al. 2016). All the studies which extracted a PP-complement out of the subject used preposition stranding, except Jurka (2010: Experiment 8) and Bianchi & Chesi (2015) which test cases both with and without preposition stranding: preposition stranding seems to lower the acceptability of the extraction out of the subject. Some studies compared different verb types (Jurka 2010, Polinsky et al. 2013, Bianchi & Chesi 2015), and their results indeed reveal some differences between verbs. But the studies do not systematically measure whether island effects disappear based on those factors. The presence of a quantifier might ameliorate extraction out of the subject, but the effect sizes are very small, thus the results are difficult to interpret (Jurka 2010: Experiment 11). Supporting context does not seem to improve extraction out of subjects (Sprouse 2007a) but relevance does (Chaves & Putnam (2020)). The results on working memory are mixed: working memory may have an impact on the acceptability ratings of extractions out of subjects, but it does not explain them (Sprouse et al. 2012). Two online studies measures investigated whether or not readers postulate a gap in the subject (Phillips 2006, Chaves & Dery 2019). Their results go in the same direction, though the authors draw opposite conclusions from them.

Table 7.2 presents studies on *wh*-questions carried out in other languages (only examining direct interrogatives).

7 Previous experimental work on subextraction from subjects

Table 7.2: Studies on *wh*-questions in other languages

Publication	Language	Subject type	Filler (island condition)	Task	Design	Results
Jurka (2010), Experiment 1	German	NP	Specifier ( <i>was-für</i> split)	Acceptability ratings, Likert scale	Crossing function (subject / object), position (NP moved before adverb / NP in situ after adverb) and extraction type (extraction of NP / extraction out of NP).	- for the subextraction, interaction function : position ( $p < 0.001$ ), in that extraction out of the "moved" subject is rated worse
Jurka (2010), Experiment 2	German	NP	Specifier ( <i>was-für</i> split)	Acceptability ratings, Likert scale	Tested passive verbs, crossing function (subject / dative object) markedness (unmarked with dative object before subject / marked with dative object after subject) and extraction (no extraction / extraction out of NP).	- extraction out of the subject rated higher than extraction out of the dative object - for extracted conditions, no interaction function : markedness
Jurka (2010), Experiment 3A	German	NP	Specifier ( <i>was-für</i> split)	Acceptability ratings, Likert scale	Tested "in situ" subjects (after the adverb), crossing argument type (subject of unaccusative / passive / transitive / unergative / object of transitive) and extraction type (no extraction / extraction out of the NP).	- for transitives, extraction out of object rated higher than extraction out subjects ( $p < 0.001$ ) - for transitives (two-by-two comparison with all other verb types), significant interactions argument : extraction type, in that extraction out of the subject is worse than the other conditions - for other extractions out of the subject, no other interaction argument : extraction type
Jurka (2010), Experiment 3B	German	NP	Specifier ( <i>was-für</i> split)	Acceptability ratings, Likert scale	Tested "in situ" subjects (after the adverb), crossing verb type (unaccusative / unergative) and extraction type (extraction of the subject / extraction out of the subject).	- interaction verb type : extraction type ( $p < 0.001$ )
Jurka (2010), Experiment 4	German	NP	Specifier ( <i>was-für</i> split)	Acceptability ratings, Likert scale	Tested embedded <i>wh</i> -questions, crossing function (subject / object), extraction type (extraction of the NP / out of the NP) and scrambling (object scrambled and before the adverb / not scrambled and after the adverb).	- extraction of subject rated higher than extraction of object ( $p = 0.0014$ ) - extraction out of subject with object scrambled rated lower than extraction out of object ( $p < 0.004$ ) - extraction out of subject without object scrambled rated lower than extraction out of object ( $p = 0.041$ ) - for subextractions, no interaction function : scrambling
Jurka (2010), Experiment 13a	Serbian	NP	Specifier	Acceptability ratings, Likert scale	Crossing function (subject / object) and extraction type (no extraction / extraction out of the NP).	- no interaction function : extraction type
Jurka (2010), Experiment 13b	Serbian	NP	PP-complement	Acceptability ratings, Likert scale	Crossing function (subject / object) and extraction type (extraction of the NP / extraction out of the NP).	- interaction function : extraction type, in that extraction out of the subject is rated lowest

Jurka et al. (2011), Experiment in 2.1	German	NP	Specifier ( <i>was-für</i> split)	Acceptability ratings, Likert scale	Crossing function (subject / object), extraction type (extraction of NP / extraction out of NP) and freezing (scrambled NP / NP in situ).	- interaction function : freezing ( $p < 0.001$ ), the condition with extraction out of the scrambled NP being rated lowest  - sentences with transitive verbs rated lower than other verb types ( $p < 0.005$ for postverbal; $p < 0.005$ for preverbal) - sentences with an unergative verb rated lower than other verb types ( $p < 0.05$ for postverbal; $p < 0.01$ for preverbal) - for transitive verbs, extraction out of the subject rated lower than extraction out of the object ( $p < 0.001$ for postverbal; $p < 0.05$ for preverbal)
Polinsky et al. (2013), Experiment 2	Russian	NP	Specifier	Acceptability ratings, Likert scale	Crossing extraction type (extraction of NP / extraction out of the NP), extraction site (subject of unaccusative / unergative / transitive / object of transitive) and subject position (preverbal / postverbal).	- interaction predicate : subject position ( $p < 0.003$ ) - for I-level, no effect of subject position ( $p = 0.6$ ) - for s-level, postverbal is rated higher than preverbal ( $p = 0.003$ )
Bianchi & Chesi (2014), Experiment 1	Italian	NP	Di-complement	Acceptability ratings, continuous scale	Tested state verbs and indefinite NPs, crossing predicate (identity-denoting / stage-denoting) and subject position (preverbal / postverbal).	- no difference between verb types ( $p = 0.932$ )
Bianchi & Chesi (2014), Experiment 2	Italian	NP	Di-complement	Acceptability ratings, continuous scale	Tested extraction out of definite postverbal subject, comparing verb types (unergative / unaccusative).	
Sprouse et al. (2016), Italian Experiment 2	Italian	NP	Di-complement	Acceptability ratings, Likert scale	Crossing function (subject / object) and extraction type (extraction of NP / extraction out of NP).	- interaction function : extraction type ( $p < 0.001$ )
Greco et al. (2017), Experiment 1	Italian	NP	Di-complement	Acceptability ratings, Likert scale	Compared extractions (extraction out of the subject / object / extraction of adjunct).	- extractions out of objects rated higher than extractions out of subjects ( $p < 0.0001$ ) - extractions of adverbs rated higher than extractions out of objects ( $p < 0.05$ )
Greco et al. (2017), Experiment 2	Italian	NP	Di-complement	Acceptability ratings, Likert scale	Crossing verb type (passive / unaccusative / unergative / transitive), extraction types (extraction out of the subject / extraction of adjunct) and subject position (preverbal / postverbal).	- for transitive verbs, preverbal subjects rated higher than postverbal ( $p = 0.0539$ ), but no effect of extraction type - for passive verbs, preverbal subject rated lower than postverbal ( $p = 0.0176$ ), but no effect of extraction type - for extractions out of the subject, unergatives rated lower than other verb types
Kush et al. (2018), Experiment 1	Norwegian	NP	PP-complement (with preposition stranding)	Acceptability ratings, Likert scale	Tested bare fillers (similar to <i>what/what</i> ), crossing extraction site (extraction in the main clause / out of embedded clause) and complexity (subject of the embedded clause simple / complex).	- interaction extraction site : complexity ( $p < 0.001$ ), in that extraction out of the complex subject is rated lowest.

## 7 Previous experimental work on subextraction from subjects

Kush et al. (2018), Experiment 2	Norwegian	NP	PP-complement (with preposition stranding)	Acceptability ratings, Likert scale	Same as previous.	- interaction extraction site : complexity ( $p < 0.001$ ), in that extraction out of the complex subject is rated lowest.
Kush et al. (2018), Experiment 3	Norwegian	NP	PP-complement (with preposition stranding)	Acceptability ratings, Likert scale	Tested complex filler (similar to <i>which NP</i> ), otherwise same as previous.	- interaction extraction site : complexity ( $p < 0.001$ ), in that extraction out of the complex subject is rated lowest
Pañeda et al. (2020)	Spanish	NP	De-complement	Speeded acceptability ratings, yes/no	Crossing extraction site (extraction in the main clause / out of embedded clause) and complexity (subject of the embedded clause simple / complex).	- interaction extraction site : complexity, so that extraction out of the complex subject is rated lowest
Kobzeva et al. (2022), wf-question	Norwegian	NP	PP-complement (with preposition stranding)	Acceptability ratings, Likert scale	Same as previous. Another construction is also tested (see Table 7.4 below).	- interaction extraction site * complexity ( $p < 0.0001$ ), in that extraction out of the complex subject is rated lowest

Some studies employed a design that makes it possible to detect island effects (Jurka 2010: Experiment 13b, Jurka et al. 2011, Sprouse et al. 2016 Greco et al. 2017: Experiment 2, Kush et al. 2018, Pañeda et al. 2020, Kobzeva et al. 2022). In those studies, there is almost systematically a significant interaction effect pointing to a potential “subject island” (unfortunately, even though Jurka (2010: Experiment 1 & 2) and Polinsky et al. (2013) used such a design, they do not report the results for the interaction). However, all except one (Greco et al. 2017) use extraction of the whole subject as a baseline to test subextraction. This is not ideal, given that extraction of the subject displays processing advantages. One study that stands out is Jurka (2010: Experiment 13a) on Serbian, which does not show a superadditive effect. Some experiments explore different verb types (Jurka 2010, Polinsky et al. 2013, Bianchi & Chesi 2014) and their results differ from the English ones: in German, Russian and Italian, different verb types seem to behave similarly as far as extraction out of the subject is concerned. The position of the subject affects the acceptability of the subject island condition (Jurka 2010, Jurka et al. 2011, Polinsky et al. 2013, Bianchi & Chesi 2014). However, the findings could be due to general preferences that have nothing to do with subextraction, since this is not controlled for with a baseline (or it is not reported).

Several experiments test extraction of the specifier in languages that allow such extraction (Jurka 2010, Jurka et al. 2011, Polinsky et al. 2013). The possibility of specifiers behaving differently than complements in subextraction is only explored in Jurka (2010: Experiment 13a&b). Indeed, Jurka (2010: Experiment 13a) does not find superadditive effects when the specifier is extracted, while Jurka (2010: Experiment 13b) observes superadditive effects in the extraction of the complement. Notice, however, that the two experiments used different baselines, namely “no extraction” (Experiment 13a) and “extraction of the NP” (Experiment 13b). Unfortunately there is no test reported for a three-way interaction.

Sprouse and colleagues also conducted a series of experiments on in-situ questions. An overview is provided in Table 7.3.

Since in-situ questions in English are uncommon and restricted to specific contexts, Sprouse (2007a) and Sprouse et al. (2011) tested them by using double interrogatives. In these constructions, when a first *wh*-phrase is extracted, a second *wh*-phrase can be in situ. The results are mixed: depending on the baseline, a superadditive effect may be observed. In Japanese, interrogatives are in situ by default, so Sprouse et al. (2011) was able to test the *wh*-phrase directly inside the subject. They found no interaction effects, which goes against an analysis of in-situ questions as covert movement. I will develop the issue of in-situ questions in more detail in Section 11.4.

Table 7.3: Studies on in-situ questions

Publication	Language	Subject type	Task	Design	Results
Sprouse (2007a), Experiment in Section 6.1.1	English	NP	Acceptability ratings, magnitude estimation	Tested double questions, comparing extraction type ( <i>wh</i> -question with extraction out of the subject / in situ).	- no difference between <i>wh</i> -questions and in-situ questions.
Sprouse (2007a), Experiment in Section 6.1.2	English	NP	Acceptability ratings, magnitude estimation	Tested double questions, crossing function (subject/object) and <i>wh</i> -phrase (whole NP/complement of NP).	- interaction function: <i>wh</i> -phrase ( $p < 0.05$ )
Sprouse (2007a), Experiment in Section 6.1.3	English	NP	Acceptability ratings, yes/no	Tested double questions, comparing extraction type ( <i>wh</i> -question with extraction out of the subject / in situ).	- both in-situ and ex-situ questions rejected
Sprouse et al. (2011), Experiment 1	English	NP	Acceptability ratings, magnitude estimation	Tested double questions, crossing <i>wh</i> -phrase (whole NP /complement of NP) and extraction type (no extraction / <i>wh</i> -question/in-situ question).	- for <i>wh</i> -questions, interaction <i>wh</i> -phrase:extraction type ( $p < 0.0001$ ) - for in-situ questions, no interaction ( $p = 0.271$ )
Sprouse et al. (2011), Experiment 3	Japanese	NP	Acceptability ratings, magnitude estimation	Crossed function (subject/object) and <i>wh</i> -phrase (whole NP/complement of NP).	- no interaction function: <i>wh</i> -phrase ( $p = 0.1368$ )

## 7.2 Other constructions

Few studies have tested non-interrogative constructions. Table 7.4 presents five such studies.

The distinction between focalizing and non-focalizing extractions is very important for the Focus-Background Conflict constraint (see Section 4). In the literature, apart from *wh*-questions, the other constructions tested are topicalization (Kush et al. 2019) and relative clauses (Sprouse et al. 2016, Kobzeva et al. 2022), both of them probably non-focalizing constructions. There is a caveat with Kobzeva et al.'s (2022) study, which examine Norwegian: as the authors note, the Norwegian demonstrative relative clause could be read as a cleft. It is thus difficult to know whether the construction tested by Kobzeva et al. is a focalizing construction or not.

All the studies observe superadditive effects, except the Italian experiment (Sprouse et al. 2016). As previously discussed, the baseline in these studies might cause a problem (if there is a subject advantage in the baseline, as in extraction of the subject in relative clauses, the interaction might be caused by this subject preference rather than by the subextraction). The Italian experiment in (Sprouse et al. 2016) is also the only one without preposition stranding.

Only Kobzeva et al. (2022) looked for a three-way interaction to compare different constructions: they found that the superadditive effect in relative clauses (or clefts) is smaller than in *wh*-questions.

## 7.3 Sentential subjects

Even though the subject island constraint was first formulated as the sentential subject island constraint (Ross 1967), there are relatively few studies on extraction out of sentential subjects. These studies are presented in Table 7.5.

The studies examined finite and non-finite sentential subjects, sometimes in the same experiment. In English, extractions out of sentential subjects are one of the worse island violation (in raw ratings), and worse for non-finite subjects than finite ones (Sprouse 2007a). In German, Jurka (2010) found superadditive effects, but again the baseline condition showed an advantage for the subject condition (meaning that the baseline increases the interaction). Extraposition does not seem to play a role. Finally, it appears that Japanese does not have a “subject island effect” (Jurka 2010, Jurka et al. 2011, Fukuda et al. 2014), in line with what was reported in the literature.

Table 7.4: Studies on other constructions

Publication	Language	Construction	Subject type	Filler (island condition)	Task	Design	Results
Sprouse et al. (2016), English Experiment 1	English	Relative clause	NP	PP-complement (with preposition stranding)	Acceptability ratings, Likert scale	Crossing function (subject/object) and extraction type (extraction of NP/extraction out of NP).	- interaction function: extraction type ( $p < 0.001$ )
Sprouse et al. (2019), Italian Experiment 1	Italian	Relative clause	NP	DI-complement	Acceptability ratings, Likert scale	Crossing function (subject/object) and extraction type (extraction of NP/extraction out of NP).	- no interaction function: extraction type ( $p < 0.84$ )
Kush et al. (2019), Experiment 1	Norwegian	Topicalization	NP	PP-complement (with preposition stranding)	Acceptability ratings, Likert scale	Tested sentences without context, crossing extraction site (extraction in the main clause/out of embedded clause) and complexity (subject of the embedded clause simple/complex).	- interaction extraction site: complexity ( $p < 0.001$ )
Kush et al. (2019), Experiment 2	Norwegian	Topicalization	NP	PP-complement (with preposition stranding)	Acceptability ratings, Likert scale	Tested sentences with supporting context, crossing extraction site (extraction in the main clause/out of embedded clause) and complexity (subject of the embedded clause simple/complex).	- interaction extraction site: complexity ( $p < 0.001$ )
Kobzeva et al. (2022), relative clause	Norwegian	Demonstrative relative clause (or cleft)	NP	PP-complement (with preposition stranding)	Acceptability ratings, Likert scale	Crossing extraction site (extraction in the main clause/out of embedded clause) and complexity (subject of the embedded clause simple/complex). <i>Wh</i> -questions are also tested.	- interaction extraction site : complexity ( $p = 0.0090$ ) - three-way interaction ( $p < 0.0003$ ), in that the interaction effect is larger for <i>wh</i> -questions than for relative clauses.



Table 7.5: Studies on sentential subjects

Publication	Language	Construction	Subject type	Filler (island condition)	Task	Design	Results
Sprouse (2007a), Experiment in Section 2.2	English	<i>Wh</i> -question	Non-finite sentential subject	Direct object	Acceptability ratings, magnitude estimation	Tested extraction out of the subject, compared with other island violations.	- rated worse than any other island violation
Sprouse (2007a), Experiment in Section 2.2	English	<i>Wh</i> -question	Finite sentential subject	Direct object	Acceptability ratings, magnitude estimation	Tested extraction out of the subject, compared with other island violations.	- rated higher than the extraction out of non-finite sentential subjects, sometimes rated higher than extraction out of adjuncts ('adjunct island')
Jurka (2010), Experiment 5	German	<i>Wh</i> -question	Non-finite sentential subject	Direct object	Acceptability ratings, Likert scale	Crossing function (subject/object), extraction (no extraction/extraction out of sentential VP) and extraposition (sentential VP extraposed with expletive <i>es</i> /not extraposed).	- interaction function:extraction, so that the extraction out of the sentential subject is rated worse - no interaction extraposition:extraction - for non-extrapped sentential VP, interaction function:extraction ( $p < 0.001$ ) - for non-extrapped sentential VP, subject rated higher than object ( $p < 0.001$ ) - for extrapped sentential VP, subject rated higher than object ( $p < 0.001$ ) - for sentential subject, interaction extraposition:extraction
Jurka (2010), Experiment 6	German	<i>Wh</i> -question	Non-finite sentential subject	Direct object	Acceptability ratings, Likert scale	Crossing function (sentential subject / sentential object) and V2 (auxiliary with past participle/main verb with present tense).	- no interaction function:V2
Jurka (2010), Experiment 7	German	<i>Wh</i> -question	Non-finite sentential subject	Direct object	Acceptability ratings, Likert scale	Crossing extraction (extraction out of the sentential subject/no extraction) and verb type (particle verb/verb without article).	- no interaction extraction:verb type
Jurka et al. (2011), Experiment in Section 2.2	German	<i>Wh</i> -question	Non-finite sentential subject	Direct object	Acceptability ratings, Likert scale	Crossing extraction type (no extraction / extraction) and function (subject/object).	- interaction extraction type:function ( $p < 0.001$ )
Jurka (2010), Experiment 12 & Jurka et al. (2011), Japanese Experiment	Japanese	Scrambling & clefts	Finite sentential subject	Direct object	Acceptability ratings, Likert scale	Crossing function (subject/object) and construction (no extraction/scrambling / cleft).	- interaction function:construction ( $p < 0.001$ ) - for scrambling, no difference between subject and object - for clefts, no difference between object and subject - for no extraction, object rated lower than subject ( $p = 0.002$ )

## 7 Previous experimental work on subextraction from subjects

Fukuda et al. (2014), Japanese Experiment	Japanese	Scrambling	Finite sentential subject	Direct object	Acceptability ratings, Likert scale	Crossing function (subject/object) and scrambling (no scrambling/scrambling).	- no interaction function:scrambling
--	----------	------------	---------------------------------	------------------	---	--	--------------------------------------

## 8 Empirical data on *dont* relative clauses

I now turn to the experimental and corpus results from my own work that form the empirical basis of this book. In this chapter, I present the results of three corpus studies and four experiments on *dont* relative clauses with inanimate antecedents. Other experiments on *dont* with an animate antecedent will be discussed in the next chapter. The organization of the chapter is the following:

*Corpus studies on dont*: In these studies, I annotated occurrences of *dont* in two different written corpora for two time periods (20th century and 21st century). The results show that extractions out of the subject are not only very frequent in written French, but in fact the most frequent use of *dont* in relative clauses. This is not restricted to subjects of passive or unaccusative verbs and is attested in both time periods.

*Experiment 1*: In this acceptability judgment study, we cross extraction type (extraction/non-extraction) with three different distances between *dont* and the gap (one new referent/two new referents/three new referents). The shortest distance is extraction out of the subject, the other ones are extractions out of the object. The results show that the longer the distance, the lower the acceptability. Contrary to what is expected from a subject island, we find that extraction out of the subject is rated significantly higher than extraction out of the object.

*Experiment 2*: In this speeded acceptability judgment study, we reproduce the design of Experiment 1 with slightly different stimuli. Sentences are presented on the screen one word at a time relatively quickly, and participants have to accept or reject the sentence within two seconds. This technique allow us to reduce the ceiling effects seen in Experiment 1, but we only obtain null effects: all conditions are acceptable to the same degree. Besides a hint that extractions out of the subject are not ruled out by grammar, Experiment 2 does not give any statistical evidence for it and does not falsify any prediction.

*Experiment 3:* In this eye tracking study, we test the same experimental material as in Experiment 1. We find relatively little variation in the participants' reading patterns, except that relative clauses seem easier to read than coordinations (non-extractions). If we compare extractions out of the subject with extractions out of the object with a nominal subject (the low and high distance conditions the data indicate at best an increase in processing difficulty for extractions out of the object.

*Experiment 4:* In this acceptability judgment study, we cross extraction type (extraction/non-extraction/ungrammatical controls) with syntactic function (subject/object). Extraction out of the subject receives significantly higher ratings than extraction out of the object. There is no interaction effect between extraction type and grammatical function.

## 8.1 Corpus studies on *dont*

This section summarizes the results of three corpus studies previously published in Abeillé et al. (2016) and Abeillé & Winckel (2020) looking at relative clauses introduced by the relative word (and complementizer) *dont*. I call them *dont* relative clauses in this work. Previously, Godard (1988) claimed that these relative clauses allow for extraction out of the NP subject. The corpus studies support Godard's claim and go beyond it, showing that this is a common and frequently attested phenomenon in French.

### 8.1.1 Motivation

*Dont* is very frequent in written (and spoken) French. That is probably the reason why the discussion on extraction out of the subject in French started with examples of *dont*-relative clauses. As mentioned in Section 2.3.1, Godard (1988) has shown that *dont* may be the complement of a subject noun, despite the general subject island constraint assumed in the syntactic tradition. However, to the best of my knowledge, Candito & Seddah (2012a) is the only corpus study providing quantitative results on *dont* in production data, even though this was not their primary concern. I will briefly present the relevant points of this study in Section 8.1.2.

Our corpus studies on *dont* pursued seven main goals. First, we wanted to have a detailed description of its usage. Blanche-Benveniste (1990) noticed that *dont* has what she calls a "fixed usage" in contemporary spoken French because it occurs almost exclusively as the complement of a verb. If this were the case in



counterexamples with the minimalist account of subject islands, Heck proposes that *dont* is not an extracted element when it is the complement of the subject, but a specifier of the subject DP. Under his proposal, the whole DP is pied-piped to the edge of the relative clause, as shown in example (8.3a). This implies that there are two different usages of *dont* for Heck (2009), because there is a filler-gap dependency when *dont* is the complement of a verb or of an object noun (8.3b).

- (8.3) a. (Heck 2009: 101)  
 la fille [dont le frère]<sub>DP</sub> t' a rencontré  
 the girl of.which the brother you.ACC has met  
 'the girl whose brother met you'
- b. la fille dont tu as rencontré [le frère -]<sub>DP</sub>  
 the girl of.which you have met the brother  
 'the girl whose brother you met'

According to Heck's analysis, no material may intervene between *dont* and the subject when *dont* is a specifier as in (8.3a): no subject inversion like (8.4a) and no long distance dependency like (8.4b) is supposed to be possible when a complement of the subject is relativized. However, such constraints have not been tested empirically.

- (8.4) a. (Heck 2009)  
 \* Colin, dont choque la coiffure blonde peroxydée  
 Colin of.which surprises the hair blond bleached  
 'Colin, whose bleached blond hair is shocking'
- b. (Tellier 1991)  
 ?? un homme dont je refuse que le fils vous fréquente  
 a man of.which I refuse that the son you.ACC dates  
 'a man of whom I refuse that the son dates you'

For this reason, our third goal was to see if we can find extractions out of the subject that are long-distance dependencies. This will be a way to test Heck's (2009) prediction.

Fourth, by annotating the kinds of verbs in the corpus, we wanted to see whether extraction out of the subject NP is predominantly found with subjects of passives or unaccusative verbs, or "internal objects" as they are sometimes called in the literature. Accounts along the line of Chomsky (2008) predict that speakers

only produce extractions out of “internal objects”, and not out of subjects which are base-generated in a specifier position.<sup>1</sup>

Fifth, we wanted to examine if extractions out of the subject differ from other uses of *dont* with respect to restrictiveness. We do not know of any accounts predicting that extraction out of the subject is sensitive to this factor, but there are different predictions as far as information structure is concerned for restrictive and non-restrictive relative clauses. According to Song (2017: 181–186), the antecedent of a non-restrictive relative clause is the “aboutness topic” of its main verb. However, there is “no additional clue” for identifying the relation that holds between the antecedent and the main verb of a restrictive relative clause. Indeed, non-restrictive relative clauses like (8.5b) can be paraphrased as (8.5c) using the test for aboutness topic, whereas restrictive relative clauses like (8.5a) cannot.

(8.5) (Song 2017: 181)

- a. Kim chases the dog that likes Lee.
- b. Kim chases the dog, which likes Lee.
- c. Kim chases the dog, and speaking of the dog, it likes Lee.

Hence, it may be the case that the extracted element in restrictive relative clauses is something other than a topic. If extraction out of the subject requires that the extracted element be non-focal, then we expect to find a higher proportion of non-restrictive relative clauses among extractions out of the subject than in other extraction types.

Sixth, we wanted to look at the distribution of extractions out of the subject in terms of their semantics, specifically, the meaning of the relation expressed by the extracted *de*-complement (spatial or temporal relations, property, possessives, etc.). This is again a more exploratory aspect of the corpus study, given that the various approaches do not make any predictions in this respect.

Our final aim was to distinguish relative clauses with an antecedent from *c’est*-cleft sentences. The latter do involve focalization, and in terms of discourse status, they are closer to *wh*-questions than to relative clauses. We will develop this idea more extensively in Section 12.1.

### 8.1.2 A previous exploration of *dont* in the FTB (Candito & Seddah)

Candito & Seddah (2012a) examined two corpora, the French Treebank (Abeillé et al. 2019, see our corpus study below) and the Sequoia treebank (Candito & Seddah 2012b), which contains sentences from the French Wikipedia, from medical

---

<sup>1</sup>See fn. 12 on page 38.

texts, from *Europarl* and from the regional newspaper *L'Est Républicain*. They looked for words involved in unbounded dependencies: the clitic *en* ('of it') and *wh*-words (relative and interrogative pronouns and determiners). The relative word *dont* is the second most frequent word in their results after the relative word *que*. They found 501 extractions with *dont*, the three most frequent types being extractions out of subject NPs (251 cases), extractions out of object NPs (29 cases) and extractions out of predicative complements (27 cases). This means that half of the extractions with *dont* are extractions out of subject NPs, a surprisingly high number if one expects these extractions to be banned by syntax. In general, Candito & Seddah note, using terminology from Dependency Grammar (see Section 3.2), that around one third of their extractions (259 out of 618 dependencies) are projective: "This is because most [long distance dependencies] are extractions from a subject NP [...]"

Even though Candito & Seddah do not provide much more detail on their results (the usage of *dont* was not what they were interested in), we can already see that extractions out of the subject, especially with *dont*, are very frequent in the two corpora, given that they represent the majority of unbounded dependencies.

### 8.1.3 Procedure

One of the corpus studies, published in Abeillé et al. (2016), was carried out on the French Treebank (FTB version 1.0, Abeillé et al. 2019). The corpus is a tagged newspaper corpus of 21 550 sentences (about 664 500 words) from the French newspaper *Le Monde* (articles from 1990 to 1993). We explored it with TIGERsearch (König & Lezius 2003). For the two other studies, published in Abeillé & Winckel (2020), we used a larger corpus, Frantext (ATILF et al. 2016) – an online collection of texts by various authors in French literature. We explored it with the online search tool of the corpus. Both the FTB and Frantext collect well-edited written productions<sup>2</sup>, but they differ in their typology, since the FTB contains many texts focusing on economical issues, while Frantext often describes protagonists and their interactions.

The ultimate aim of the two studies in Frantext was to compare *dont* and *de qui* in order to confirm Tellier's (1990, 1991) intuitions (cf. Section 2.3.1). To do this, and because the *de qui* relative clauses only have animate antecedents, we only selected animate antecedents for the *dont* relatives as well. In order to detect changes over time, we selected two similar periods in Frantext: texts published

---

<sup>2</sup>My colleagues and I also presented a corpus study on spontaneous spoken French in Abeillé et al. (2016).



between 1900 and 1913 (179 texts, about 7.8 million words), and texts published between 2000 and 2013 (222 texts, about 13.2 million words).

We looked for occurrences of *dont* in the corpus. Since Frantext contains too many occurrences of this word (see Figure 8.1), we only annotated a random subset of the output.

Table 8.1: Occurrences of *dont* in the French Treebank and Frantext

	French Treebank	Frantext	
		2000–2013	1900–1913
total occurrences of <i>dont</i>	632	more than 13 000	close to 10 000
total annotated	632	500	1300
among which:			
- relative clauses			
with a verb a one gap <sup>a</sup>	382	123	176
- <i>c'est</i> clefts	2	1	3

<sup>a</sup>For Frantext: only with animate antecedents, as explained above.

These corpora are annotated for part of speech and lemmas. All other annotations had to be done manually. First, it was necessary to remove occurrences that are “noise” (i.e. false positives of a given query that are not what we were looking for). Second, we wanted to test the impact of certain factors on the results, e.g. whether there were any occurrences of extractions out of a subject. To this end, it was necessary to annotate these factors for each occurrence.

We found only 6 *c'est*-clefts among the occurrences we annotated. The two clefts in (8.6) are extractions of the complement of a verb.

- (8.6) a. [FTB - flmf7ajlep-212]  
 C' est de semi- retraite dont parle M. Tapie.  
 it is of semi retirement of.which talks Mr Tapie  
 'It is semi-retirement that Mr Tapie is talking about.
- b. [FTB - flmf3\_11000\_11499ep-11113]  
 C' est de l' indépendance tout court dont il a été  
 it is of the independence all short of.which it has been  
 finalement question.  
 finally question.  
 'In the end, it was simply a matter of independence.'

Example (8.7) is extraction out of the object. However, it is presentational, and thus more similar to English *there*-clefts than English *it*-clefts.

- (8.7) (La Mort de Philæ, Pierre Loti, 1909)  
 C' est la momie d' un embryon humain, dont on avait dans  
 it is the mummy of an embryo human of.which one had in  
 les temps orné [le visage \_] d' une belle couche d' or [...].  
 the times decorated the face of a nice layer of gold  
 'This is the mummy of a human embryo, of whom someone had  
 decorated the face with a nice layer of gold in a timely manner.'

The three remaining *c'est*-clefts, reproduced in (8.8), are interesting because they display extraction out of the subject. However, (8.8b) is presentational and (8.8c) is probably presentational as well. Only (8.8a) is actual focalization by means of extraction.

- (8.8) a. (Jean-Christophe : Le Buisson ardent, Romain Rolland, 1911)  
 C' était lui maintenant, dont [les yeux \_] évitaient les yeux  
 it was him now of.which the eyes avoided the eyes  
 de l' autre.  
 of the other  
 'Now it was him whose eyes avoided the other's eyes.'
- b. (Le protocole compassionnel, Hervé Guibert, 2007)  
 C' était donc le jeune homme dont [le livre de chevet \_]  
 it was then the young man of.which the book of bedside  
 était resté longtemps *Des aveugles*.  
 was stayed long of.the blinds  
 'So this is the young man whose bedtime reading had been for a  
 long time *About the blinds*.'
- c. (Sermons, fragments et lettres, Horace Monod, 1911)  
 [...] c' est un mourant dont [les traits \_ creusés par la  
 it is a dying of.which the face drilled by the  
 souffrance] s' éclairent d' une céleste joie [...]  
 suffering REFL shine of an unearthly joy  
 'It's a dying man, whose face, deformed by the suffering light up  
 with an unearthly joy [...].'

Extraction out of the subject is therefore attested in clefts. Unfortunately, with so little data we cannot draw any further meaningful conclusions. The analysis below does not take the *c'est*-clefts into account.

Furthermore, I only present the analysis for relative clauses with a verb and one gap. The partitive verbless *dont* relative clauses like (8.9) of the French Treebank have already been described by Bilbâie & Laurens (2010). In the present analyses, we ignore gapless *dont* relative clauses like (8.10) and relatives with different gap sites.<sup>3</sup>

(8.9) [FTB - flmf7aa1ep-328]

En Amérique latine, 23 journalistes ont trouvé la mort, dont 9  
in America Latin 23 journalists have found the death of. which 9  
en Colombie et 7 au Pérou.

in Colombia and 7 in Peru.

‘In Latin America, 23 journalists have died, among which 9 in  
Colombia and 7 in Peru.’

(8.10) [FTB - flmf7ak1ep-272]

Un bel effort, dont l’avenir dira s’il persuade les  
a nice effort of. which the future will. say if it persuades the  
consommateurs, s’il suscite des imitateurs [...]

consumers if it generates DET imitators

‘A fine effort, and the future will tell us whether consumers are  
persuaded and whether it will be imitated.’

In order to present all corpus studies in this work in a uniform and consistent way, some minor corrections have been made to the annotation (see the guidelines in Appendix A). The values may therefore vary slightly from those reported in the respective publications.

#### 8.1.4 Results and analysis

Table 8.2 summarizes the functions of *dont* in the three corpora. They are also displayed in Figures 8.1 and 8.2.

---

<sup>3</sup>We distinguish between several gaps and different gap sites. If there are several gaps, but with the same syntactic function, like in (8.1.a), they are included in the results below. If the different gaps have different syntactic functions and are therefore at different gap sites, like in (8.1.b), then they are not considered in the result. This holds for for all corpus studies in this work.

- (i) a. the car of which [the wheels \_] and [the brakes \_] are defective
- b. the car of which [the driver \_] broke [the wheels \_]

## 8 Empirical data on *dont* relative clauses

Table 8.2: Distribution of *dont* relative clauses in the French Treebank and Frantext

Frequency	French Treebank	Frantext 2000–2013	Frantext 1900–1913
Verb	74 (19.42%)	25 (20.33%)	20 (12.20%)
Noun			
Subject	216 (56.69%)	60 (48.78%)	99 (60.37%)
Object	48 (12.60%)	31 (25.20%)	35 (21.34%)
Predicate	26 (6.82%)	4 (3.25%)	4 (2.44%)
Adjective	6 (1.57%)	3 (2.44%)	6 (3.66%)
Adjunct	11 (2.89%)	0	0

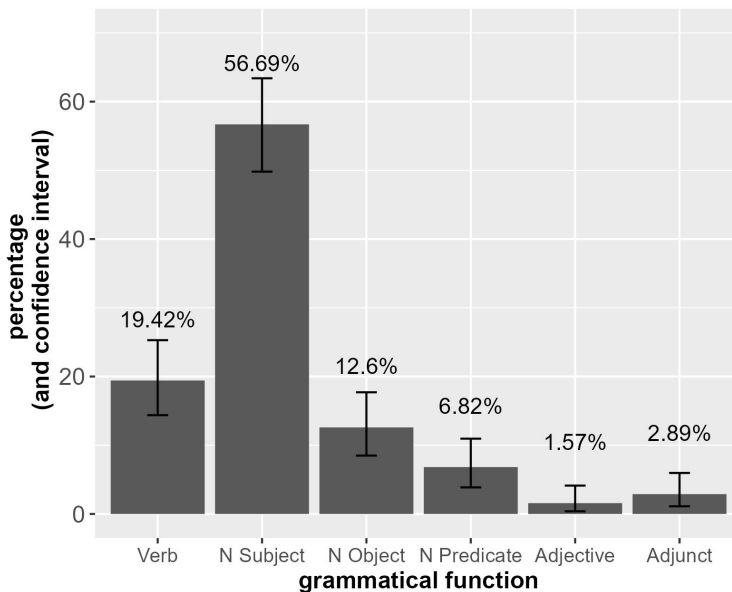
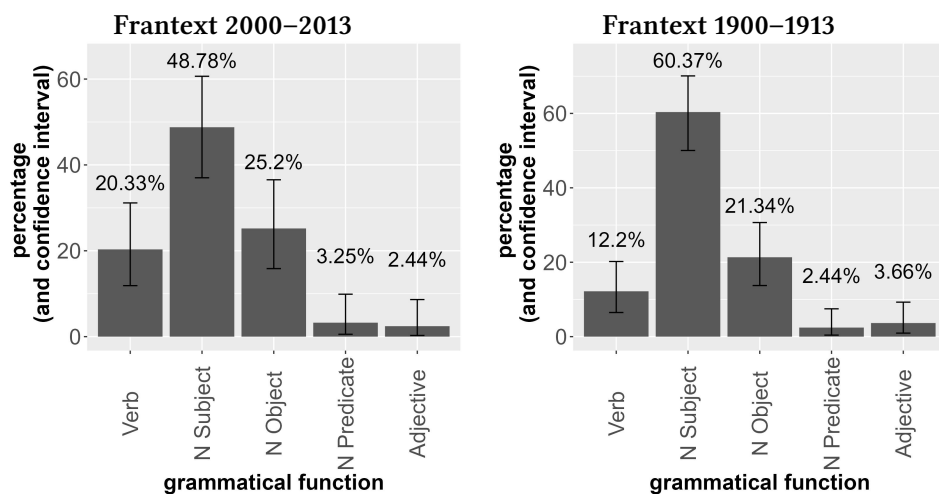

Figure 8.1: Distribution of *dont* relative clauses in the French Treebank

Figure 8.2: Distribution of *dont* relative clauses in Frantext

#### 8.1.4.1 Confidence intervals for frequency

As mentioned before, the advantage of quantitative data is that they show the broader tendencies in the usage of a language while concealing individual preferences. In order to achieve this, it is necessary to identify and treat the outliers accordingly. Outliers are exceptional outcomes, which are present in quantitative data but do not reflect the general tendency. Let us assume that extraction out of subjects is indeed completely out in French. Let us assume in addition that, in a million occurrences of a given filler in a given corpus, one is in fact a case of extraction out of a subject: this fact should not suffice to falsify the hypothesis that such structures are ruled out. Indeed, even in a well-edited text, an error may have been overlooked by proofreaders, or made intentionally to create a feeling of strangeness. Hence, we need statistical validation that few occurrences are more than marginal. In this respect, the size of the corpus is also important: one out of ten occurrences for 1000 occurrences is a more reliable rate than one out of ten occurrences for 20 occurrences. In order to take this into account, I perform an exact test of a simple null hypothesis about the probability of success in a Bernoulli experiment with the function `binom.test()` from the R Stats Package (R Core Team 2018): this test gives us confidence intervals with a probability of 95% where the number of occurrences of each structure is compared

to the total size of our subcorpus.<sup>4</sup> This confidence level of 95% is corrected for multiple comparisons when needed. For example, in Figure 8.1, it is corrected for 6 comparisons, and in Figure 8.2 for 5 comparisons.

If the lower bound of the confidence interval for one structure is smaller than 0.5 occurrences, we consider the frequency of this structure to be not significantly above 0. However, the fact that a given structure does not occur – or that it occurs with a frequency that is not significantly above zero – does not necessarily mean that the structure is ruled out by the grammar of the language. We can only say that the corpus data do not contradict the hypothesis that this structure is out in the language.

#### 8.1.4.2 Functions of *dont* attested in the corpus

As expected, *dont* can have any function of a *de*-PP except being the complement of a preposition (or of a noun complement of a preposition). It can therefore either be complement of a verb (8.11), of a noun (8.12) or of an adjective (8.13a) or be an adjunct (8.14).

(8.11) Some examples of *dont* as verb complement

a. (FTB - flmf7af2ep-602)

Le gouvernement n' avait ni écrit ni choisi cet  
the government NEG had neither written nor chosen this  
accord [dont nous avons hérité -].  
agreement of.which we have inherited

'The government had neither written nor chosen this agreement  
that we inherited.'

b. (L'enfant d'Austerlitz, Paul Adam, 1902)

De nouvelles figures s' imposaient bientôt, dont [il  
of new faces REFL imposed soon of.which he  
attendait plus de charmes -].  
expected more of charms

'New faces soon establish themselves, from which he expected  
more charms.'

---

<sup>4</sup>The package documentation indicates that the “confidence intervals are obtained by a procedure first given in Clopper & Pearson (1934)”.

(8.12) Some examples of *dont* as noun complement

## a. Subject noun (FTB - flmf7al1ep-66):

C' est ce qu' a annoncé récemment M. Georges Fillioud,  
it is this that has announced recently Mr Georges Fillioud  
PDG, dont [le mandat \_] devrait être reconduit .

CEO of.which the mandate should be renewed

'This is the recent announcement of Mr Georges Fillioud, CEO,  
whose mandate should be renewed.'

## b. (Demain il fera beau : journal d'une adolescente (novembre 1939-1944), Denise Domenach-Lallich, 2001)

Je suis partie avec Georges Lesèvre, étudiant en Lettres

I am left with Georges Lesèvre student in Literature

dont [le père \_], [la mère \_] et [le frère \_] avaient été

of.which the father the mother and the brother had been

arrêtés puis déportés.

arrested then deported

'I left with Georges Lesèvre, a literature student whose mother,  
father and brother had been arrested, and then deported.'

## c. Object noun:

(Un peu de désir sinon je meurs, Marie Billetdoux, 2006)

Et chaque pore de ma peau, alors, est un chien qui se

and every pore of my skin then is a dog who REFL

redresse, dont on a touché [la laisse \_]...'

get.up of.which one has touched the leash

'And every pore of my skin is then like a dog who stands up, the  
leash of whom someone touched...'

## d. (Dingley, l'illustre écrivain, Jérôme Tharaud, 1906)

Elle ne bougea pas, afin de ne pas réveiller son mari,

she NEG moved not so.that of NEG not wake.up her husband

dont elle redoutait [la violence \_].

of.which she feared the violence.

'She did not move, so as not to wake up her husband, the violence  
of whom she feared.'

8 Empirical data on *dont* relative clauses

- e. Predicate noun (FTB - flmf7ag1exp-449):  
 Le premier n' avait pas les faveurs de France Télécom,  
 the first NEG had not the support of France Télécom  
 dont Matra Communication est [l' un des tout premiers  
 of.which Matra Communication is the one of.the very first  
 fournisseurs -].  
 suppliers

'The first one did not have the support of France Télécom, of  
 which Matra Communication is one of the very first suppliers.'

- f. (La légende des cycles, Jean-Noël Blanc, 2003)  
 Fignon se rebelle contre Hinault, dont il a été  
 Fignon REFL rebel against Hinault of.which he has been  
 [lieutenant -] : provocation [...].  
 lieutenant provocation  
 'Fignon rebels against Hinault, who he has been the lieutenant of:  
 (that's a) provocation.'

(8.13) Some examples of *dont* as an adjective complement

- a. (FTB - flmf7aa2ep-513)  
 Ils ôtent à la politique monétaire ses références  
 they remove from the policy monetary its references  
 chiffrées dont les membres du directoire sont  
 quantitative, of.which the members of.the directorate are  
 [friands -].  
 fond

'They deprive the monetary policy of its quantitative benchmarks,  
 which the members of the management board are fond of.'

- b. (La vie après, Virginie Linhart, 2012)  
 Sans doute n' imaginait - il plus sa vie sans ma  
 without doubt NEG imagined he anymore his life without my  
 grand-mère dont il était [fort épris -] ?  
 grandmother of.which he was very in.love

'Without doubt, he could not imagine anymore to live without my  
 grandmother, who he was in love with?'

(8.14) An example of *dont* as an adjunct (FTB - flmf7an2co-919)

La GSA conteste la manière dont [l' armée de l' air  
 the GSA contests the manner of.which the army of the air



américaine a mené l' évaluation des différentes  
 American has led the evaluation of the different  
 propositions –] [...].  
 proposals

‘The GSA contests the manner in which the American air force led the  
 different proposals’ evaluation.’

There is a very high number of extractions out of NPs. For the 21st century (FTB and Frantext), they represent around 3/4 of usages of *dont*, but the proportion is even higher in Frantext 1900–1913. In all cases, most of them are extractions out of the subject. Except for Frantext 2000–2013, extractions out of the subject are significantly more frequent than extractions out of the object. This provides further support that extractions out of the subject are possible with *dont* (Godard 1988), and are in fact the most frequent case (Candito & Seddah 2012a).

The occurrences of *dont* as an adjunct in FTB are almost exclusively *la manière dont* or *la façon dont* (‘the way how’). Such usages were not found in our Frantext corpus, because we only considered relative clauses with animate antecedents. For this reason, there are no occurrences of *dont* as an adjunct in our Frantext results.

#### 8.1.4.3 Subject position

Although possible, subject-verb inversion is very rare in our results, as can be seen in Table 8.3. It is strikingly more frequent in the FTB, probably for stylistic reasons that have to do with journalistic writing.<sup>5</sup> Extraction out of the subject is very rare as well, but is attested.

Table 8.3: Subject-verb inversions in the French Treebank and Frantext

Nb of occurrences	French Treebank	Frantext	
		2000–2013	1900–1913
postverbal subjects in total	36	6	5
extractions out of a postverbal subject	0	4	1

<sup>5</sup>In Abeillé et al. (2016), we show that, most of the time, these postverbal subjects appear when there is extraction out of the verb. We argue that, in this case, the cost for subject-verb inversion is counterbalanced by a reduction of filler-gap dependency length.

## 8 Empirical data on *dont* relative clauses

For extraction out of a subject, using a postverbal subject instead of a preverbal one increases the linear distance between the relative word and its gap. Processing accounts (DLT or UD) therefore predict that this configuration will be avoided.

All five occurrences of extraction out of a postverbal subject are reported in (8.15).

- (8.15) a. (Dans la main du diable, Anne-Marie Garat, 2006)  
 les morts, dont se dissout dans l' air [la présence \_]  
 the deads of.which REFL dissolves in the air the presence  
 'the dead ones, whose presence vanishes in the air'
- b. (Dans la main du diable, Anne-Marie Garat, 2006)  
 Millie, dont grandissait [l' angoisse \_]  
 Millie of.which grew the anxiety  
 'Millie, whose anxiety was growing'
- c. (Entretiens et conférences II [1979–1981], Georges Perec, 2003)  
 Pierre Getzler, dont est reproduite [une gravure \_]  
 Pierre Getzler of.which is reproduced an engraving  
 'Pierre Getzler, an engraving of whom is reproduced'
- d. (Voix off, Denis Podalydès, 2008)  
 Éric Elmosnino lui-même, dont nous charment [la voix \_],  
 Éric Elmosnino himself of.which us.ACC charm the voice  
 [la présence \_], [le mouvement \_], [la malice \_].  
 the presence the movement the craftiness  
 'Éric Elmosnino himself, whose voice, presence, movement and  
 craftiness charm us.'
- e. (L'Inde (sans les Anglais), Pierre Loti, 1903)  
 [l]es monstres cabrés, dont se reconnaissent déjà [les  
 the monsters rearing of.which REFL recognise already the  
 silhouettes \_].  
 shapes  
 'the rearing monsters, whose shapes are already recognizable'

Postverbal subjects are counterexamples to Heck's (2009) analysis of *dont* as being inside the subject NP. As a native speaker, I find these sentences unproblematic and well-formed.

I can report a few more cases challenging Heck's (2009) account. The first one is questionable: in (8.16), a negative conjunction (*ni...ni...*) stands between *dont* and the subject. One could possibly argue that both the negative particle and *dont* occupy the specifier position of D, but this would be an unusual analysis.

- (8.16) (La vie sexuelle de Catherine M. précédé de Pourquoi et Comment, Catherine Millet, 2001)  
ces êtres privés [...] de l' usage de leurs membres et de celui  
these beings deprived of the use of their limbs and of the one  
de la parole, mais dont ni [l' intelligence \_] ni [le  
of the speech but of which neither the intelligence nor the  
besoin \_ de communiquer] ne sont altérés  
need of communicate.INF NEG are modified  
'these beings, deprived of the use of their limbs and of the ability to  
speak, but of whom neither the intelligence nor the need to  
communicate have been modified'

Another problematic case is given in (8.17). Here, the extracted *de*-PP is the complement of the *de*-PP complement of the subject noun. If *dont* in (8.17) is situated in the specifier position of DP, then it cannot be in the specifier position of the DP of its head noun, but it must be in the specifier position of the DP of the head of its head noun. Such a configuration is not explicitly expected by Heck (2009), but perhaps it is not entirely incompatible with his hypothesis (e.g. in assuming cyclic movement inside the subject NP).

- (8.17) (FTB - flmf7ag2ep-663)  
[les] chômeurs [...] dont [les durées [d' affiliation \_]] sont les  
the unemployed of whom the period of affiliation are the  
plus courtes  
most short  
'the unemployed whose period of affiliation are the shortest'

Finally, there is an indisputable case of a long-distance dependency in (8.18), a possibility which was explicitly ruled out by Heck's (2009) analysis.

- (8.18) (Voix off, Podalydes, 2008)  
madame Segond-Weber, la grande tragédienne, dont il aime  
Madame Segond-Weber the great tragedian of whom he likes  
**rappeler que** [les répliques \_] tombaient de sa bouche « comme  
recall.INF that the lines felt of her mouth like  
des fûts de colonne ».  
some shafts of column  
'Madame Segond-Weber, the great tragedian, of who he enjoys  
recalling that the lines fall out of her lips « like pillars ».'

The attested examples in (8.15) and (8.18) show that Heck's (2009) explanation cannot hold. His analysis of *dont* is contradicted by the empirical data. Even cases such as (8.16) and (8.17) would be hard to conciliate with his approach.

## 8.1.4.4 Verb types

Following some generativist approaches on syntax (notably, Chomsky 2008), extracting out of the subject of a passive or unaccusative verb is extraction out of the (underlying) direct object. Table 8.4 shows the verb types involved in extractions out of the subject in our corpora. We can see that all types are attested. Transitives (8.19a), unergatives (8.19b) and state verbs (8.19c) are frequent. Passives (8.19d) are more frequent in the FTB than in Frantext, and more frequent in the 21st century than in the 20th century. Unaccusatives (8.19e) and mediopassives (8.19f) are attested, but not frequent. Mediopassives are generally rare in our relative clauses.

Table 8.4: Verb types in extractions out of the subject among *dont* relative clauses

Verb type	French Treebank	Frantext 2000–2013	Frantext 1900–1913
Passive	53 (24.54%)	8 (13.33%)	9 (9.09%)
Unaccusative	17 (7.87%)	7 (11.67%)	9 (9.09%)
Mediopassive	4 (1.85%)	4 (6.67%)	5 (5.05%)
Transitive	49 (22.69%)	15 (25.00%)	33 (33.33%)
Unergative	29 (13.43%)	12 (20.00%)	22 (22.22%)
State	64 (29.63%)	14 (23.33%)	21 (21.21%)

- (8.19) a. (Tête d'or [2e version], Paul Claudel, 1901)  
 Les soldats, dont [quelques-uns \_] portent des drapeaux,  
 the soldiers of.which some carry DET flags  
 envahissent la salle.  
 overrun the room  
 'The soldiers, of which some are carrying flags, run into the room.'
- b. (Besoin de vélo, Paul Fournel, 2001)  
 [l]es tatanes de Greg LeMond dont [les pieds \_] ne  
 the big.shoes of Greg LeMond of.which the feet NEG  
 ressemblaient à rien de connu dans le peloton [...]  
 resembled at nothing of known in the peloton  
 'the big shoes of Greg LeMond, whose feet were like nothing else  
 that was known in the peloton [...]'

- c. (FTB - flmf3\_08500\_08999ep-8561)  
 La fumée contenait en effet du oxyde cyanhydrique dont  
 the smoke contained in effect some oxide hydrocyanic of.which  
 [les effets \_] sont immédiats.  
 the effects are immediate  
 ‘The smoke indeed contained some hydrogen cyanide, whose effects are immediate.’
- d. (L’arrivée de mon père en France, Martine Storti, 2008)  
 les morts de Lampedusa dont [les noms \_] sont illustrés  
 the dead.PL of Lampedusa of.which the names are illustrated  
 de photos  
 of photographs  
 ‘The dead of Lampedusa whose names are illustrated with photographs’
- e. (Rendez-vous, Christine Angot, 2006)  
 une actrice dont [le fils \_] voulait devenir metteur en  
 an actress of.which the son wanted become.INF director of  
 scène [...]  
 stage  
 ‘an actress whose son wanted to become a stage director [...]’
- f. (Terres lorraines, Emile Moselly, 1907)  
 Pierre, dont [la haute taille \_] s’ encadrait dans la  
 Pierre of.which the high size REFL frame in the  
 fenêtre  
 window  
 ‘Pierre, whose high figure framed itself in the window’ (intended:  
 the window formed a frame around his high figure)

We can compare the verb types involved in extraction out of the subject with the verb types in other kinds of extractions. Figure 8.3 illustrates this for the French Treebank. Taking into account the confidence intervals, the only difference seems to be that, in extraction out of subjects, passives are more frequent and unergatives are less frequent than in other kinds of extractions. Similar observations can be made for the two corpus studies on Frantext. However, this has a simple explanation: extraction out of objects nouns or predicate nouns cannot involve a passive, and we have seen that extraction out of nouns is very frequent in the corpus. The second most frequent case are extractions of the complement of the verb, and since most *de*-PP complement of verbs are complements of an

## 8 Empirical data on dont relative clauses

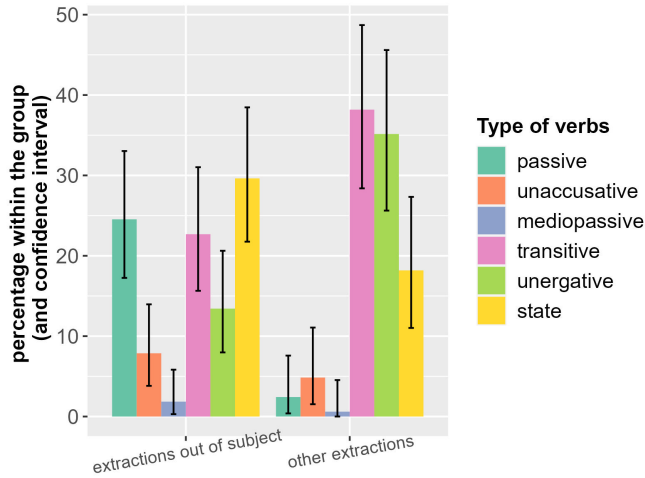

Figure 8.3: FTB: Distribution of the type of verb involved among extractions out of the subject, compared to other type of extractions in *dont* relative clauses. See page 129 for the confidence intervals (here six comparisons). The percentage is given for each group (extraction out of the subject vs. other extraction).

unergative verb, it is also clear why the category “other kinds of extractions” contains such a high proportion of unergatives. We do not need to assume that extraction out of the subject is especially felicitous with passives or especially infelicitous with unergatives.

Crucially, a non-marginal number of extractions out of subjects contain transitive verbs: Figure 8.4 shows a binary distinction between transitive verbs and the other verb types. Transitives are around 1/4 of the verbs involved in extraction out of the subject: 22.69% in the French Treebank, 25% in Frantext 2000–2013 and 33.33% in Frantext 1900–1913. We note that this correlates with the proportion of transitives in the other extraction types. Thus, the small number of transitive verbs is not specific to extraction out of the subject but rather a general tendency in the French Treebank, maybe as a consequence of the text genre. There are more transitive verbs in the group “other kinds of extractions”, but this does not mean that the number of transitives is especially low among extractions out of the subject: the group “other kinds of extractions” contains extractions out of a direct object, which necessarily imply the presence of a transitive verb.

To sum up, we can indeed confirm that there are more non-transitive than transitive verbs among extractions out of the subject. And indeed, we find a considerable number of passives and state verbs among them. This may explain why

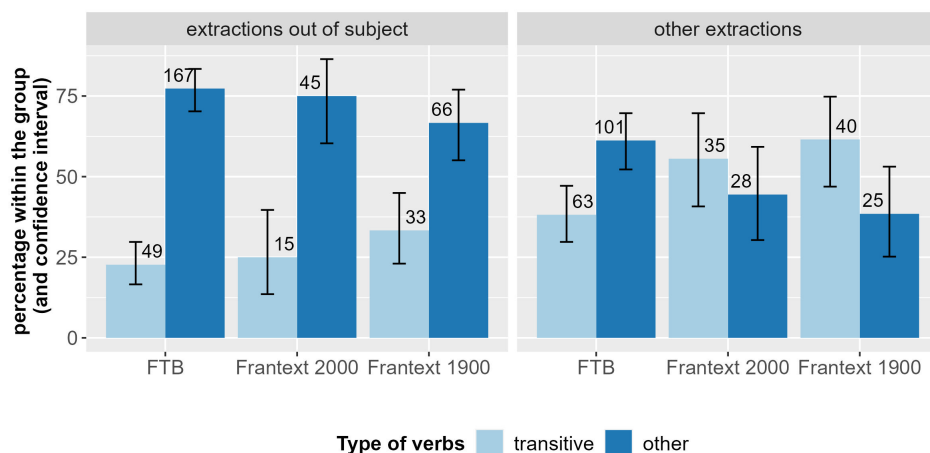

Figure 8.4: Distribution of transitive verbs in *dont* relative clauses. See page 129 for the confidence intervals (here two comparisons). The percentage is given for each group (a group = one kind of extraction in one corpus).

many of the examples we find in the literature are extractions out of the subject of a passive or state verb. This could even be the reason for the sense in the literature that extraction out of the subject sounds particularly good with these kinds of verbs. However, this does not mean that extraction out of the subject is degraded – let alone ungrammatical – with transitive verbs, since such extractions are still common.

#### 8.1.4.5 Other factors

We annotated the relative clauses for several other factors: the number (singular/plural) and definiteness of the antecedent, the restrictiveness of the relative clauses and the semantic relation holding between *dont* and its head noun. I briefly summarize the relevant findings in this section, and include more details in Appendix C.

Number and definiteness of the antecedent do not seem to follow any specific pattern.

We find a clear tendency for extraction out of the subject to be non-restrictive relatives. This result is expected under the FBC constraint (4.31): if we assume that the extracted element in relative clauses may be non-topical (thus potentially focus) and that extraction out of the subject requires that the extracted element be

non-focal, then extraction out of the subject should display a preference for non-restrictiveness. In line with this, there are more non-restrictive relative clauses among extractions out of the subject than in other extraction types: presumably speakers opt for an alternative construction when they wish to express a restrictive relative clause with a focused extracted element.

As for the semantic relation holding between *dont* and its head noun, extraction type plays at best a minor role. More important are (i) the text genre of the corpora (newspaper article vs. literary text) and (ii) whether or not we restrict our results to animate antecedents. However, by comparing extractions out of subjects vs. of objects in Frantext 2000–2013 and 1900–1913, the kind of relation was close to being a good predictor for the gap site. In general, we found many part-whole relations (especially for body parts) in extractions out of the subject, and many patient-event relations in extractions out of the object.

### 8.1.5 General conclusion on the corpus studies on *dont*

All these corpus results converge on one major point: extracting out of the subject with *dont* is not only possible, but is in fact its most common usage. In Frantext 2000–2013, it does not significantly differ from extraction out of the object, but it is significantly different from all other kinds of extractions in FTB and Frantext 1900–1913. This corroborates Godard (1988), but also any account based on minimizing the distance between the relative word and the gap. In general, extraction out of NPs is very frequent (over 3/4 of all extractions in all three corpora).

Extraction out of subjects of transitive verbs is attested in all corpora, and is actually a very frequent case. This means that extraction out of subject cannot be claimed to be restricted to cases of underlying objects, but is also found for what all theories on syntax consider as “real” subjects. Even if one assumes subject movement as in Minimalism, the data show clear evidence that there is no freezing effect blocking the extraction.

However, we can also observe in all three corpora that passives are more frequent among extractions out of subjects than among all other kinds of extractions. We can also see that transitives are less frequent among extractions out of subjects than among all other kinds of extractions. This does not mean that there are more passives than transitives among the extractions out of the subject: in fact, Frantext 1900–1913 has significantly more transitives, and in the two other corpora, the proportions of passives and transitives are very similar. This may however explain French scholars’ intuitions that extractions out of the subject are especially good with passives, and especially bad with transitives.<sup>6</sup>

---

<sup>6</sup>It is also important to take into account some parameters that may affect our results:



In Godard (1988), all felicitous examples of extraction out of the subject contain the state verb *être* ('be'). Indeed, extraction out of the subject of state verbs tends to be frequent, but possibly Godard used these in order to construct simple sentences with a very straightforward semantic content. Similarly, the reason for using passives to illustrate extraction from subjects in the literature may be that such sentences are relatively simple. No other conclusion should be drawn from this choice, at least as far as production data are concerned.

In Frantext 2000–2013, we find evidence that material can stand between *dont* and the subject NP it is extracted from. This contradicts Heck (2009). The fact that intervening material rarely appears after *dont* is easy to understand under accounts assuming that speakers tend to minimize the linear distance between *dont* and the gap. These accounts can also explain why constructed counterexamples have been judged as degraded in the literature (e.g., Tellier 1990). But the corpus data provide evidence that extractions out of subjects with *dont* are “real” extractions.

## 8.2 Experiment 1: Acceptability judgment study on *dont* relative clauses with different linear distances

The goal of this first experiment was to test the opposite predictions of two approaches. We pitted the traditional syntactic approach against a processing approach based on memory costs. We compared extraction out of the subject with extraction out of the object: the traditional syntactic approach predicts a subject island, whereas approaches based on memory load predict a subject advantage.<sup>7</sup>

- 
- With a passive verb, there are few possible gap sites for a *de*-PP besides one inside the subject itself. This fact alone can explain why there are more passives in this group than in other kinds of extractions.
  - Extraction out of an object NP necessarily involves transitive verbs, no other verb type is possible. This fact alone can explain why there are more transitives in the “other kinds of extractions” group.
  - Extraction of the *de*-complement of a verb can only involve unergative verbs, and no other verb type. This fact alone can explain why there are so much unergatives in the “other kinds of extractions” group.

In this respect the factors are not completely independent of each other. This weakens the conclusion that we can draw from the comparison.

<sup>7</sup>We replicated Experiment 1 with a slightly different 3\*2 design in Abeillé et al. (2020). The results of the replication study do not differ in any major way from those I present in this section.

### 8.2.1 Design and materials

The experiment used an acceptability judgment task with a  $3 \times 2$  design. We compared extractions out of the subject (8.20a) and extractions out of the object (8.20b). In this experiment, we manipulated not only different gap sites, but also the distance between the relative word and the gap, which has an impact on the memory load. For this reason, I call the subject condition the “narrow-distance” condition and the object condition the “wide-distance” condition.

- (8.20) a. Condition narrow-distance + PP-extracted:  
Ils présentent une innovation dont<sub>i</sub> [l’ originalité <sub>-i</sub>]  
they present an innovation of.which the uniqueness  
émerveille mes collègues.  
delights my colleagues  
‘They present an innovation of which the uniqueness delights my  
colleagues.’
- b. Condition wide-distance + PP-extracted:  
Ils présentent une innovation dont<sub>i</sub> mes collègues  
they present an innovation of.which my colleagues  
apprécient [l’ originalité <sub>-i</sub>].  
value the uniqueness  
‘They present an innovation of which my colleagues value the  
uniqueness.’

The relation between *dont* and the gap always expressed a quality (e.g. *originalité* ‘uniqueness’, *beauté* ‘beauty’). The noun out of which extraction takes place was always inanimate. We used subject/object experiencer psych verbs in pairs with similar semantics (e.g., *apprécier* ‘value’ and *émerveiller* ‘delight’) in order to have transitive verbs but also in order to compare sentences whose content is as similar as possible. In all extraction conditions, the extraction took place out of the stimulus argument of the verb. Using transitive verbs was crucial, because some syntactic accounts only expect a subject island for subjects of transitive verbs. It was also important to keep the content maximally similar between the subject and object conditions. We saw in Chapter 4 that the relevance of the extracted element for the main proposition is central for the acceptability of filler-gap dependencies. By keeping the content the same, we ensure that the relevance for the main proposition remains constant.

In the narrow-distance condition (extraction out of the subject) in (8.20a), one new referent is introduced into the discourse (*originalité*). In the wide-distance

condition (extraction out of the object) in (8.20b), the number of referents is three (*collègues*, *apprécier* and *originalité*). We added a third intermediate category, with two referents between *dont* and the gap, by using a clitic subject instead of a nominal one in the extraction out of the object, as in (8.21).

(8.21) Condition medium-distance + PP-extracted:

Ils présentent une innovation dont<sub>i</sub> nous apprécions [l'  
they present an innovation of.which we value the  
originalité <sub>-i</sub>].  
uniqueness

‘They present an innovation of which we value the uniqueness.’

To create a grammatical baseline, the three distance conditions were used in a coordination construction which contains no extraction. The material in (8.22a), (8.22b) and (8.22c) are thus the respective controls for (8.20a), (8.21) and (8.20b).

(8.22) a. Condition narrow-distance + noextr:

Ils présentent une innovation et son originalité émerveille  
they present an innovation and its uniqueness delights  
mes collègues.  
my colleagues

‘They present an innovation and its uniqueness delights my colleagues.’

b. Condition medium-distance + noextr:

Ils présentent une innovation et nous apprécions son  
they present an innovation and we value its  
originalité.  
uniqueness

‘They present an innovation and we value its uniqueness.’

c. Condition wide-distance + noextr:

Ils présentent une innovation et mes collègues apprécient  
they present an innovation and my colleagues value  
son originalité.  
its uniqueness

‘They present an innovation and my colleagues value its uniqueness.’

We tested 30 items, each manipulated according to the six conditions described above. In addition, the experiment included 36 distractors.

## 8.2.2 Predictions

The aim of this experiment was to test the predictions of the traditional syntactic account and of processing accounts based on memory costs.

The traditional syntactic account predicts a subject superadditivity effect when extracting out of the subject. First of all (8.20a) should be degraded compared to (8.20b). The expected interaction effect is presumably that (8.20a) is worse than all three conditions (8.20b), (8.22a) and (8.22c). At the same time, under syntactic accounts there should be no difference between the two conditions of extraction out of an object. Therefore they also predict that (8.20a) should be degraded compared to (8.21), and that there should be an interaction in that (8.20b) is worse than all three conditions (8.21), (8.22a) and (8.22b).

By contrast, processing accounts based on memory load predict that extraction out of the subject should be better than extraction out of the object: there is only one intervening new referent in discourse between *dont* and the gap in (8.20a), but two referents for (8.21) and three referents for (8.20b). Therefore, these processing approaches expect (8.20a) to be more acceptable than (8.21) and (8.20b), and (8.21) to be more acceptable than (8.20b). The extraction baseline is also expected to be less costly than the extraction conditions, and thus a main effect of extraction type is predicted with higher acceptability for non-extraction than for extraction.

## 8.2.3 Procedure

Thirteen of the experiments presented in this book used the acceptability judgment task with non-binary responses on a Likert scale. Acceptability judgment tasks are a widespread formal method for linguistic experiments<sup>8</sup>: they are technically easy to set up, are conducted on online platforms by untrained participants, often on a volunteer basis which makes them very cheap to run. They also seem highly robust, results are reproducible, and in line with other experimental paradigms: Pechmann et al. (1994) carried out a comparison with offline acceptability judgment tasks and conclude that acceptability judgment tasks provide reliable results (see also Keller 2001, Sorace & Keller 2005, Gibson & Fedorenko 2013). Provided that there is a careful experimental design, it is a reliable method to compare conditions (Schütze 2016, Tonhauser & Matthewson 2015).

The acceptability judgment tasks were set up on the online platform Ibex (Drummond 2010). For every experiment, the homepage consisted of a short welcome text with an explanation of the task and of the duration of the experiment.

---

<sup>8</sup>Tonhauser & Matthewson (2015) surveyed 40 papers on meaning and report that 3/4 of them use acceptability judgment tasks.

Participants were told that they were free to close their browser and thus delete their answers at any time, and that the data collected do not enable researchers to identify them. They had to give their consent before proceeding to the experiment. The experimental items (test items and distractors in at least a 1:1 ratio) were presented one sentence at a time on the screen. Each session began with 3 practice items which were explicitly identified as such and gave the participants the opportunity to get used to the judgment task. Participants had to judge each sentence on a Likert-scale from 1 to 10, 1 being labeled as “bad” and 10 being labeled as “good”.<sup>9</sup> The description explicitly mentioned that there was no right or wrong answer. Typically, 7-point (sometimes 5-point) Likert scales are used in psychology and psycholinguistics for this kind of experiments. However, the Laboratoire de Linguistique Formelle of the Université Paris Cité traditionally uses a 10-point Likert scale for experiments with French native speakers. This is because the French school system (including preschool and university) makes extensive use of a 10-point (alternatively 20-point) grade system, thus French participants are very familiar with this scale, more so than with a 7-point scale. After the rating, some experiments included a comprehension question to stimulate the participants’ attention. The order of presentation of the items can have an impact on the participants’ judgments (e.g. because of fatigue, see Schütze 2016: 180–181). To balance this out, the sentences were pseudo-randomized for each participant. Pseudorandomization ensured that participants would not see two consecutive sentences in the same condition. I used a Latin square design so participants saw each test item only once and in only one condition, but they saw each condition equally often.

This experiment took approximately 20 minutes to complete. Participants were recruited on the R.I.S.C. website (<http://experiences.risc.cnrs.fr/>) and on social media (e.g. Facebook); they did not receive any financial compensation.

#### 8.2.4 Participants

The study was conducted in January and February 2016. 55 participants took part in the experiment. We present here the analysis of the data from the 44 participants who satisfied all inclusion criteria. Exclusion criteria were the same for all experiments I present in this book; they are described in Appendix D. 28

---

<sup>9</sup>The main difference between a 0 to 10 Likert scale and a 1 to 10 Likert scale is that the former provides a value in the middle of the scale, whereas the latter does not. On the contrary, a 0 to 10 Likert scale forces the participants to choose between more than average and less than average. I used both scales, depending on the experiment, and never noticed any difference in the results.

participants self-identified as women, 16 self-identified as men; their age range from 19 to 73 years. Seven participants (15.91%) indicated having an educational background related to language.

### 8.2.5 Results and analysis

Figure 8.5 displays the results of the acceptability judgment task. In the subextraction conditions, acceptability ratings were highest in the narrow-distance condition (mean rating: 8.41), followed by the medium-distance condition (mean: 8.30) and finally, the wide-distance condition (mean rating: 7.88). The average acceptability for the control conditions without extraction was lower: acceptability ratings were highest in the narrow-distance condition (mean rating: 7.23), followed by the medium-distance condition (mean: 7.08) and the wide-distance condition (mean rating: 7.00).

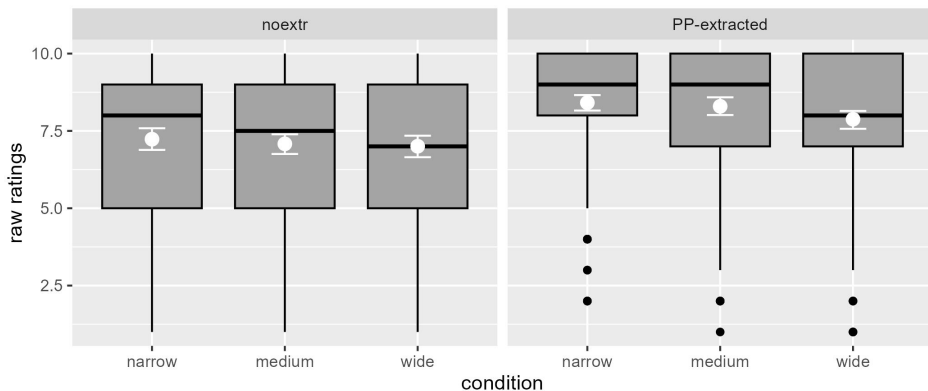

Figure 8.5: Acceptability judgments for each condition in Experiment 1. The grey box plots indicate the median and quartiles of the results. Black points are outliers. Mean and confidence intervals are indicated in white.

Figure 8.5 suggests a ceiling effect in the extraction conditions. Figure 8.6 shows a normal distribution of the ratings with a strong ceiling effect for the extraction conditions (on the right). There also appears to be a ceiling effect, albeit smaller, in the non-extraction conditions (on the left).

Another representation of the results is given by the ROC (Receiver Operating Characteristic) and zROC curves in Figure 8.7.<sup>10</sup> The ROC curve shows that the participants discriminated between the *dont*-relative clauses (extraction) and

<sup>10</sup>See the methodology for Receiver Operating Characteristic curves below.

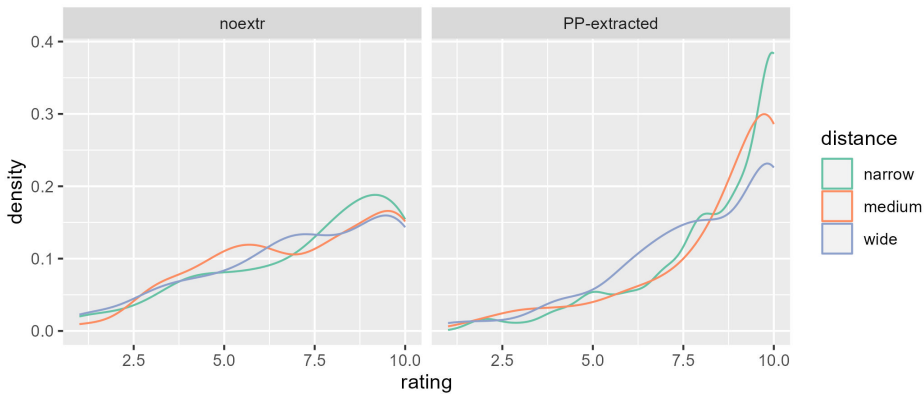

Figure 8.6: Density of the ratings across conditions for Experiment 1

the coordinations (non-extraction). We can also see that the narrow-distance and medium-distance conditions are rather similar, while the wide-distance condition receives slightly lower judgments. However, the difference is not large. The zROC curves for the wide-distance and narrow-distance conditions are straight lines, which, following Dillon & Wagers (2019: 21–22), constitutes a visual cue that the underlying acceptability distribution is normally distributed. The line of the medium-distance condition is slightly convex, which can be a visual cue of bimodality. Bimodality could be due to a strong change of acceptability during the experiment (decreasing “habituation” effect) that I present below.

### 8.2.5.1 Cumulative Link Mixed Models

In acceptability judgment tasks, participants are asked to rate sentences on a Likert scale. Until recently, ANalysis Of VAriance (ANOVA) or linear models were typically used to identify interaction effects in acceptability judgements.<sup>11</sup> But these models assume continuous numeric variables, thus they are problematic for ordinals like acceptability judgments, as Dillon & Wagers (2019) illustrate with some simulations. Standardized ratings (z-scores) are somewhat more appropriate in this respect, but they are not ideal, because we cannot be certain that the choice e.g. between a rating of 2 vs. 3 in a participant’s judgment represents the same “size” difference as the choice between 5 and 6.

Cumulative Link Mixed Models, on the other hand, avoid these problems and are well-suited for analyzing ordinal variables. They are now easily available on

<sup>11</sup>This includes my earlier work (Abeillé et al. 2016, 2020, Abeillé & Winckel 2020).

## 8 Empirical data on dont relative clauses

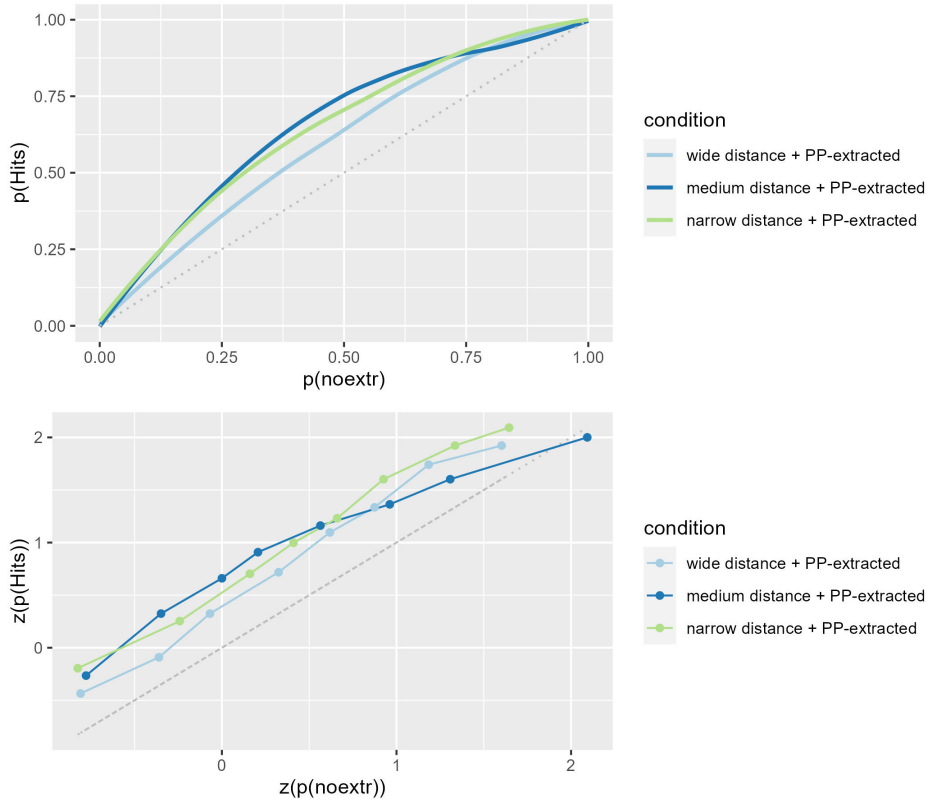

Figure 8.7: ROC curves (top) and zROC curves (bottom) of the extraction conditions compared to their respective non-extraction condition, represented by the dotted grey baseline (Dillon & Wagers's method) in Experiment 1. For the zROC curve, I had to exclude level 2 of the scale from the graph. The proportion of hits for this level in the PP-extracted + narrow-distance condition was 100%, which leads to a z-score of  $+\infty$ .



R. The analyses in this book were carried out using the function `c1mm()` from the `ordinal` package (Christensen 2019).

Following the “best practices” recommendations by Barr et al. (2013: 275–277) for linear mixed models, I included random slopes for all fixed effects grouped by participants and items in my Cumulative Link Mixed Models (because including only random intercepts can be anti-conservative, at least in linear models) and fitted a maximal model whenever convergence was achievable. If the model did not converge, I would step back to non-maximal models. This procedure has flaws and using a Bayesian inference method would be more adequate to avoid false positive results, but I leave this for future research.

There is, to my knowledge, no method of residual diagnostics for Cumulative Link Mixed Models.

### 8.2.5.2 Signal Detection Theory & Receiver Operating Characteristic curve

Dillon & Wagers (2019) proposed an alternative way to analyse the results of acceptability judgments by using tools of Signal Detection Theory. Following the methodology in that paper, I built Receiver Operating Characteristic (ROC) curves for the different conditions. The ROC curve is constructed by comparing the cumulative probability of hits at every point on the scale for one condition with the respective cumulative hits for another condition: the probability that participants will click on 0 for point 0, the probability for participants to click on 0 or 1 for point 1, the probability for participants to click on 0, 1 or 2 for point 2, and so on. The “better” condition is then plotted with respect to the “worse” one, which serves as a baseline. The Area Under the Curve (AUC) provides a graphical representation of how well the participants were able to discriminate between the two conditions: the larger the AUC, and especially the further away it is from the baseline (AUC = 0.5), the more the participants discriminated between the two conditions.

I used the function `roc()` from the `pROC` package (Robin et al. 2011) to calculate the AUCs. For the graphical representation, I carried out the calculations and plotted the curves with `ggplot2` (Wickham 2016), because the `pROC` package does not provide a way to plot multiple ROC curves.

I also constructed the respective zROC curves, following the same methodology, except that the probabilities of hits were transformed into *z*-scores. Dillon & Wagers (2019) explain how the visual inspection of the zROC curve allows first conclusions about the distribution of the underlying ratings and helps identify bimodality in the data.

The AUC is a measure of the difference between two conditions. By comparing two AUCs in a 2x2 design, we can see whether there is a difference between two

differences, which is basically the definition of an interaction effect. I used the function `roc.test()` from the `pROC` package (Robin et al. 2011) for the analysis. Even though I examined one-sided hypotheses (i.e., hypotheses that expect one specific AUC to be significantly larger than the other AUC), I used two-sided tests for the difference in AUCs, to reduce the number of statistical tests, as different hypotheses with opposite predictions were tested simultaneously. Notice that I did not correct the confidence level for multiple comparisons.

A significant difference between two AUCs is an indicator of an interaction effect, and can corroborate the results of the Cumulative Link Mixed Models. In my experience, the methodology from Signal Detection Theory proposed by Dillon & Wagers (2019) is more conservative than Cumulative Link Mixed Models. It is less likely to refute the null hypothesis with a significant probability than CLMM.

### 8.2.5.3 Habituation

Figure 8.8 depicts the habituation effects in the course of the experiment. In general, the acceptability remains unchanged during the experiment, except for the two extractions out of the object whose acceptability declines. Especially extraction out of the object with a clitic subject (medium-distance) shows a strong decrease.

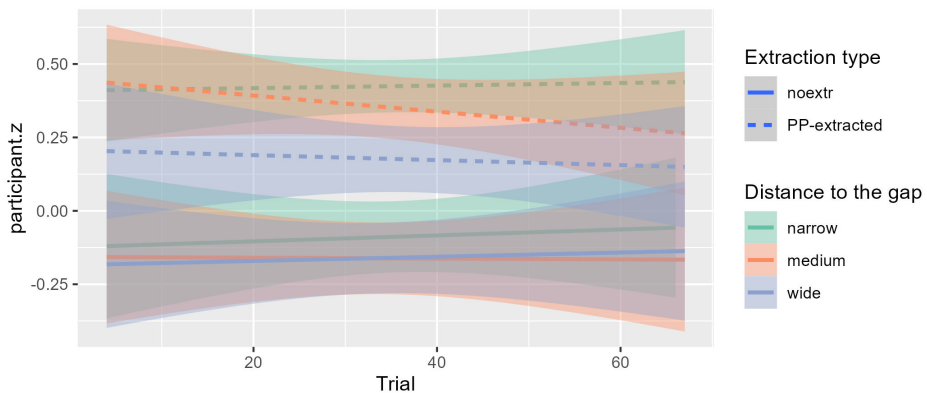

Figure 8.8: Changes in the average acceptability ratings (z-scored by participant) for each condition of Experiment 1 in the course of the experiment

### 8.2.5.4 Comparing the narrow-distance condition with the wide-distance condition

The first model was fitted to compare extraction out of the subject and out of the object on its own (mean centered with subject coded negative and object coded positive). We included trial number as a covariate, and random slopes for fixed effects and covariates grouped by participants and items. The results of the model are reported in Table 8.5. There is a significant effect of the distance (or grammatical function), but not of trial (habituation). This is expected under the processing account, and displays the opposite pattern than the one predicted by the syntactic account (the value is expected to be positive, but it is negative in the results).

Table 8.5: Results of the Cumulative Link Mixed Model (model  $n^{\circ}1$ )

	Estimate	SE	$z$	$\Pr(>  z )$	Odd. ratio
distance	-0.341	0.064	-5	<0.001	1.41
Trial	-0.001	0.004	-0	0.7113	1.00

We fitted a second model crossing distance and extraction type (mean centered with extraction coded positive, non-extraction coded negative). We included trial number as covariate, and random slopes for all fixed effects and covariates grouped by participants and items. The results of the model are shown in Table 8.6. There is a significant main effect of the distance (or grammatical function) and of extraction type, but no main effect of trial (habituation). There is also a significant interaction: the difference between the extraction and non-extraction conditions is larger in the narrow-distance conditions than in the wide-distance conditions. The interaction is showed in Figure 8.9.

Table 8.6: Results of the Cumulative Link Mixed Model (model  $n^{\circ}2$ )

	Estimate	SE	$z$	$\Pr(>  z )$	Odd.ratio
distance	-0.284	0.087	-3	<0.005	1.33
extraction type	0.628	0.126	5	<0.001	1.87
trial	0.001	0.005	0	0.9145	1.00
distance:extraction type	-0.175	0.081	-2	<0.05	1.19

However, if we compare the Area Under the Curve (AUC) for the ROC curves of the two distance conditions (see Figure 8.7 on page 148), the difference is not significant.

## 8 Empirical data on dont relative clauses

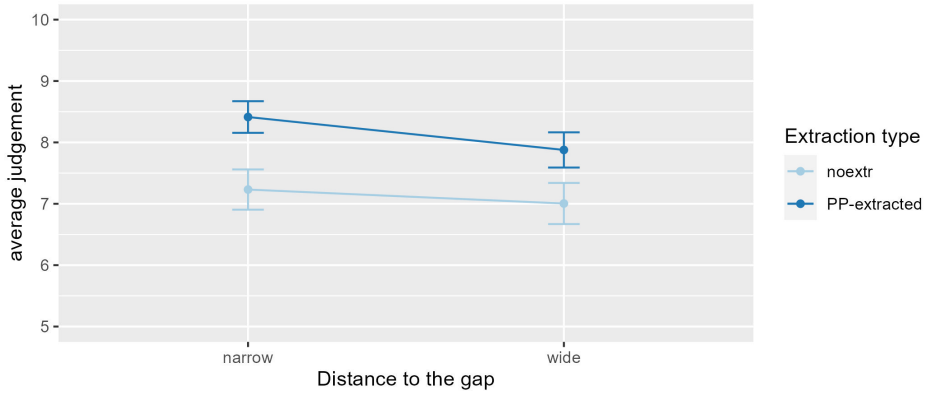

Figure 8.9: Interaction between distance and extraction type in Experiment 1. The graph only shows the narrow-distance and wide-distance conditions.

### 8.2.5.5 Comparing the narrow-distance condition with the medium-distance condition

A third model was fitted to compare extraction out of the subject and out of the object on its own (mean centered with subject coded negative and object coded positive). We included trial number as a covariate, and random slopes for fixed effects and covariates grouped by participants and items. The results of the model are given in Table 8.7. The difference is not significant.

Table 8.7: Results of the Cumulative Link Mixed Model (model n°3)

	Estimate	SE	z	Pr(>  z )	Odd.ratio
extraction type	2.664	0.184	14	<0.001	14.36
trial	0.005	0.007	1	0.5357	1.00

A fourth model crossed distance and extraction type (mean centered with extraction coded positive, non-extraction coded negative). We included trial number as a covariate, and random slopes for all fixed effects and covariates grouped by participants and items. The results of the model are reported in Table 8.8. There is a main effect of extraction type, but no main effect of distance or trial and no interaction effect. The interaction is illustrated by Figure 8.10.

The comparison of the Area Under the Curve (AUC) for the ROC curves of the two distance conditions also yields a non-significant difference (see Figure 8.7 on

Table 8.8: Results of the Cumulative Link Mixed Model (model n°4)

	Estimate	SE	z	Pr(>  z )	Odd.ratio
extraction type	0.834	0.159	5	<0.001	2.30
distance	-0.097	0.104	-1	0.3491	1.10
trial	0.000	0.006	0	0.9967	1.00
extraction type:distance	-0.014	0.083	0	0.8684	1.01

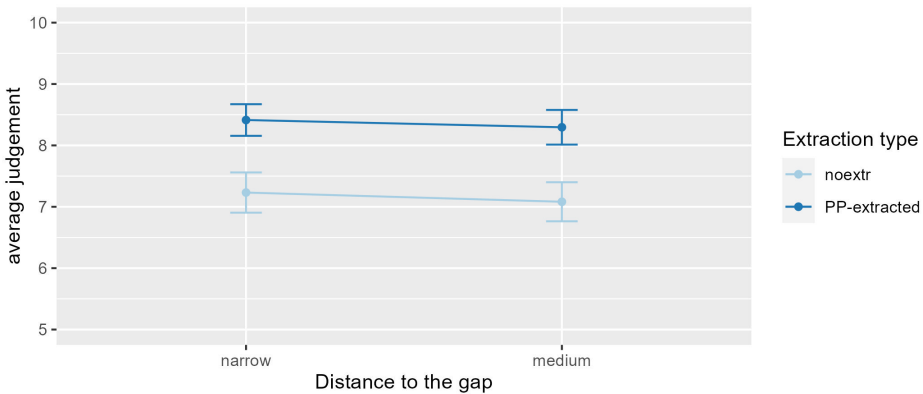

Figure 8.10: Interaction between distance and extraction type in Experiment 1. The graph only shows the narrow-distance and medium-distance conditions.

page 148).

### 8.2.5.6 Comparing the medium-distance condition with the wide-distance condition

A fifth model was fitted to compare extraction out of the object with a clitic subject vs. a nominal subject on its own (mean centered with clitic coded negative and nominal coded positive). We again included trial number as a covariate, and random slopes for fixed effects and covariates grouped by participants and items. The results of the model are reported in Table 8.9. The difference is not significant.

The last model crossed distance and extraction type (mean centered with extraction coded positive, non-extraction coded negative). As before, we included trial number as a covariate, and random slopes for all fixed effects and covariates

## 8 Empirical data on dont relative clauses

Table 8.9: Results of the Cumulative Link Mixed Model (model n°5)

	Estimate	SE	z	Pr(>  z )	Odd.ratio
distance	-0.003	0.063	0	0.9604	1.00
trial	-0.001	0.004	0	0.8379	1.00

grouped by participants and items. The results of the model appear in Table 8.10. There is a main effect of extraction type and a main effect of distance (higher ratings in the medium-distance than in the wide-distance condition). There is however no effect of trial (habituation) and no significant interaction. The interaction is illustrated by Figure 8.11.

Table 8.10: Results of the Cumulative Link Mixed Model (model n°6)

	Estimate	SE	z	Pr(>  z )	Odd.ratio
extraction type	0.629	0.124	5	<0.001	1.88
distance	0.213	0.076	3	<0.01	1.24
trial	0.001	0.005	0	0.8325	1.00
extraction type:distance	0.173	0.090	2	0.0553	1.19

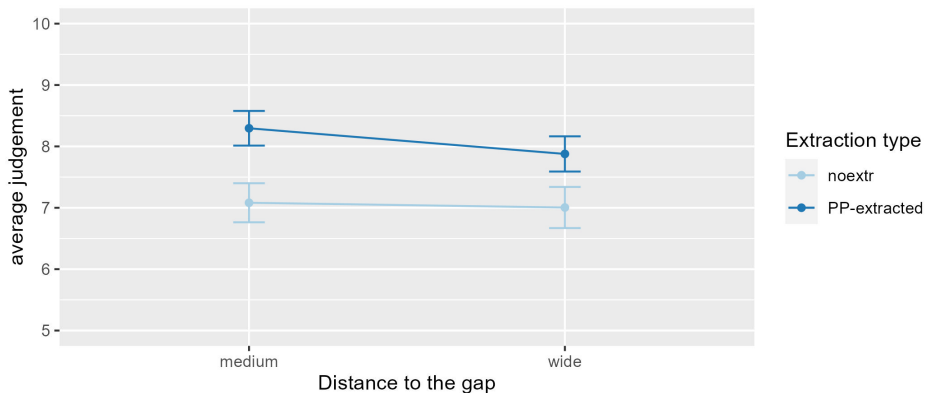

Figure 8.11: Interaction between distance and extraction type in Experiment 1. The graph only represents the medium-distance and wide-distance conditions.

If we compare the Area Under the Curve (AUC) for the ROC curves of the two

distance conditions (see Figure 8.7 on page 148), the difference is not significant, either.

### 8.2.6 Discussion

We start by comparing the results of the analysis with the predictions of the traditional syntactic approach: The expected degradation in subextraction from subject (8.20a) compared to subextraction from object conditions (8.20b, 8.21) was not manifested in the data: the difference between subextraction from a subject and from an object with a nominal subject is significant, but with subextraction from the object being worse (model n°1). We detected an interaction effect (model n°2) with a rather small effect size (odds ratio of 1.19), but, again, the pattern goes against the predictions of syntactic accounts: The interaction is caused by extraction out of the object being worse, not better, than extraction out of the subject.

Notice that our results are also problematic for other kinds of accounts that expect a penalty for extracting out of the subject. With 30 items for six conditions, participants only saw the extraction out of subject condition five times during the experiment: according to Chaves & Dery (2019), this is not sufficient to obtain improvement of ratings due to habituation.

We can now compare the results to the predictions of processing approaches based on memory costs. Here, the acceptability means are at least pointing in the right direction: the mean ratings for the narrow-distance extraction were higher than for the medium-distance extraction, which, in turn, were higher than for the wide-distance extraction. However, this difference was only significant for the two extremes, i.e. between narrow-distance and wide-distance (model n°1); the medium-distance extraction condition did not significantly differ from the other two (models n°3 and n°5). Even between the two extremes, the effect size was rather small (odds ratio 1.39), but this is expected if the effect is caused by processing factors. The interaction between narrow and wide (model n°2) is also compatible with a superadditive effect. But notice that this interaction was only significant in the Cumulative Link Mixed Models, not in the AUCs. To conclude, even though the data did not exactly reproduce the predictions of the DLT (or any other model based on memory load), they at least did not run counter to these predictions.

The habituation graph (Figure 8.8 on page 150) shows a strange pattern for the medium-distance condition (extraction and non-extraction alike), whose acceptability strongly decreased in the course of the experiment. I cannot find any

explanation for this phenomenon. Notice however that there is no main effect of trial in model n°5, therefore this decrease of acceptability was not significant.

Finally, some remarks are in order on the low acceptability of the non-extraction condition: I do not know of any study on long-distance dependencies in any other language in which the non-extraction control was found to be less acceptable than the extraction condition (island or non-island). This conflicts with the assumption that acceptability reflects processing costs, since extractions are more costly. The reason might be the high frequency of *dont* relative clauses in French and French speakers' attitude to stylistic properties of sentences. Our corpus results revealed that *dont* relative clauses were very frequent (especially with extraction out of an NP). At the same time, the control conditions involve a certain anaphoric repetition (*an innovation... its originality*) which could be considered redundant because the *dont* relative clause alternative is permitted. Armstrong (2001: 133) points out the "still highly normative and formal teaching methods employed in French schools to teach the language". Unnecessary repetitions are strongly stigmatized by the French education system: they get corrected almost systematically in written productions, and are described as "unelegant" or "heavy". In a task involving written stimuli, participants may be influenced by their school experience and give lower acceptability ratings to the coordination conditions. This phenomenon is known as social desirability (Edwards 1957): a distortion of the participants' results toward metalinguistic judgments that reflect the (socially favored) norm instead of the actual grammatical competence.

On the other hand, it must be acknowledged that better ratings for the relative clauses than for coordinations is consistent with an analysis of *dont* as a "hanging topic": the *dont* relative clauses would then be coordinate-like structures, but without an anaphoric determiner as in the baseline condition, hence their higher acceptability (reflecting lower processing costs). This does not explain the interaction found between extraction out of the subject and out of the object, though.

The fact that the extraction conditions were perceived to be better than the non-extraction conditions had an unfortunate and unintended consequence for our results: Figure 8.6 on page 147 indicates a ceiling effect in the extraction conditions, which may flatten the results of the models.



## 8.3 Experiment 2: Speeded acceptability judgment study on *dont* relative clauses with different linear distances

As we just saw, in Experiment 1 the *dont* relative clauses received very high ratings across the board, thus ceiling effects may hide potential interactions. Standard acceptability judgment experiments are untimed and participants can go back and reread earlier parts of the sentence if necessary. This is different in speeded acceptability judgment tasks, where words are presented one at a time. We therefore hoped that this technique would increase processing difficulty in the extraction conditions, thereby making the differences between the (narrow-, medium- and wide-)distance conditions more visible. We use stimuli very similar to the materials of Experiment 1 in a new experiment.

### 8.3.1 Design and materials

In this speeded acceptability judgment experiment, we used the same 3\*2 design as in Experiment 1 but slightly changed the materials. For the subextraction conditions, the item began with an open question, whose answer was an NP with a relative clause. Like in Experiment 1, the narrow-distance condition (8.23a) contained extraction out of the subject, the medium-distance condition (8.23b) extraction out of the object with a clitic subject, and the wide-distance condition (8.23c) extraction out of the object with a nominal subject.

- (8.23) a. Condition narrow-distance + PP-extracted:  
 Quel genre d' innovation ont - ils présentée hier ? Une  
 which kind of innovation have they presented yesterday an  
 innovation dont<sub>i</sub> [l' originalité -<sub>i</sub>] émerveille mes collègues.  
 innovation of.which the uniqueness delights my colleagues  
 'What kind of innovation did they present yesterday? An  
 innovation of which the uniqueness delights my colleagues.'
- b. Condition medium-distance + PP-extracted:

---

<sup>11</sup>The reason for this change is that the materials were mixed with stimuli from another experiment, which served as distractor items. The other experiment presented question/answer pairs, and we wanted to mimic these structures to ensure that the participants would not be able to distinguish the two sets of items from each other.

8 Empirical data on *dont* relative clauses

Quel genre d'innovation ont-ils présentée hier ? Une  
which kind of innovation have they presented yesterday an  
innovation dont<sub>i</sub> nous apprécions [l'originalité <sub>-i</sub>].  
innovation of which we value the uniqueness  
'What kind of innovation did they present yesterday? An  
innovation of which we value the uniqueness.'

- c. Condition wide-distance + PP-extracted:

Quel genre d'innovation ont-ils présentée hier ? Une  
which kind of innovation have they presented yesterday an  
innovation dont<sub>i</sub> mes collègues apprécient [l'  
innovation of which my colleagues value the  
originalité <sub>-i</sub>].  
uniqueness  
'What kind of innovation did they present yesterday? An  
innovation of which my colleagues value the uniqueness.'

Like in Experiment 1, the non-extraction controls involved coordinations. They were followed by a yes/no question, whose answer was always "yes". The distractors were all polar questions, followed by "yes" or "no" answers in a 1:1 ratio.

- (8.24) a. Condition narrow-distance + noextr:

Ils ont présenté une innovation hier ? Oui, et son  
they have presented an innovation yesterday yes and its  
originalité émerveille mes collègues.  
uniqueness delights my colleagues  
'Did they present an innovation yesterday? Yes, and its  
uniqueness delights my colleagues.'

- b. Condition medium-distance + noextr:

Ils ont présenté une innovation hier ? Oui, et nous  
they have presented an innovation yesterday yes and we  
apprécions son originalité.  
value its uniqueness

'Did they present an innovation yesterday? Yes, and we value its  
uniqueness.'

- c. Condition wide-distance + noextr:

Ils ont présenté une innovation hier ? Oui, et mes  
 they have presented an innovation yesterday yes and my  
 collègues apprécient son originalité.  
 colleagues value its uniqueness  
 ‘Did they present an innovation yesterday? Yes, and my  
 colleagues value its uniqueness.’

We tested the same 30 items as in Experiment 1, each manipulated according to the six conditions described above. In addition, the experiment included 28 distractors.

### 8.3.2 Experimental method

Speeded acceptability judgment tasks differ from usual acceptability judgment tasks in two ways: the experimental items are displayed on the screen word by word (for a duration between 300 and 400ms per word), and judgments must be made as fast as possible. The decision is binary: participants have to either accept or reject the sentence.

This kind of task forces participants to rely on their intuition. Indeed, the time at their disposal during reading and the judgment is too short for metalinguistic thinking to take place (Riou & Hemforth 2018: 5). Bader & Häussler (2010) compare speeded acceptability judgment tasks with other methodologies (acceptability judgment task and magnitude estimation) and conclude that it yields compelling results.

### 8.3.3 Predictions

Because this experiment used the same design as the previous one, the predictions were also the same. Again, our aim was to compare the predictions of the traditional syntactic account with the predictions of a processing account that only relates on memory costs.

Unlike the the standard acceptability judgment task, participants were asked to make a binary yes/no decision. The underlying assumption is that the more acceptable a condition is the less likely participants will be to reject the items in this condition.

The traditional syntactic account predicts a difference between extraction out of the subject (8.23a) and extraction out of objects (8.23b) and (8.23c), such that the former should receive significantly more rejections.

By contrast, a processing account based on memory load would expect acceptability to increase as the filler-gap distance decreases. This means that (8.23a)

should receive significantly fewer rejections than (8.23b), and (8.23b) should in turn receive significantly fewer rejections than (8.23c).

### 8.3.4 Procedure

We constructed six lists with a Latin square design such that each participant saw each item and distractor in only one condition. The items on each list were in a pseudo-randomized order, to ensure that no two experimental items and no two distractors occurred in a row.

The experiment was conducted at the Laboratoire de Linguistique Formelle (LLF) of the Université Paris Cité.<sup>12</sup> Participants were tested individually in a soundproof room. They received instructions from the experimenter and provided informed consent.

The experiment was run on a computer using the E-Prime software (Schneider et al. 2012).<sup>13</sup> Experimental items were presented on the screen in a word-by-word fashion. Words were presented for 250ms + 25ms for each character (such that longer words were displayed longer). After the last word of the sentence, participants had to either accept or reject it by pressing the S or the L key, respectively. If no response was provided within 2 seconds, the trial was aborted and the program moved on to the next sentence. Participants could pause between two experimental items.

### 8.3.5 Participants

The study was conducted in June 2016. 33 participants took part in the experiment, all native speakers and monolinguals. They were recruited on the R.I.S.C. website (<http://experiences.risc.cnrs.fr/>). Participants' age ranged from 18 to 75 years old. They received a financial retribution of 5€ for their participation.

### 8.3.6 Results and analysis

Figure 8.12 shows the results of the speeded acceptability judgment task. We can see that all conditions were judged acceptable in more than 3/4 of the cases. In the subextraction conditions, the narrow-distance condition (8.23a) was accepted in 77% of the cases, the medium-distance condition (8.23b) in 79% of the cases, and the wide-distance condition (8.23c) in 79% of the cases. The control conditions

---

<sup>12</sup>When the experiment was run, the university was named Université Paris-Diderot – Paris VII.

<sup>13</sup>I wish to thank Etienne Riou, who set up the experiment and conducted it at the Université Paris Cité, and Doriane Gras, who also helped with the use of E-Prime.

had a slightly higher acceptability: 78% in the narrow-distance condition (8.24a), 85% in the medium-distance condition (8.24b) and 79% in the wide-distance condition (8.24c).

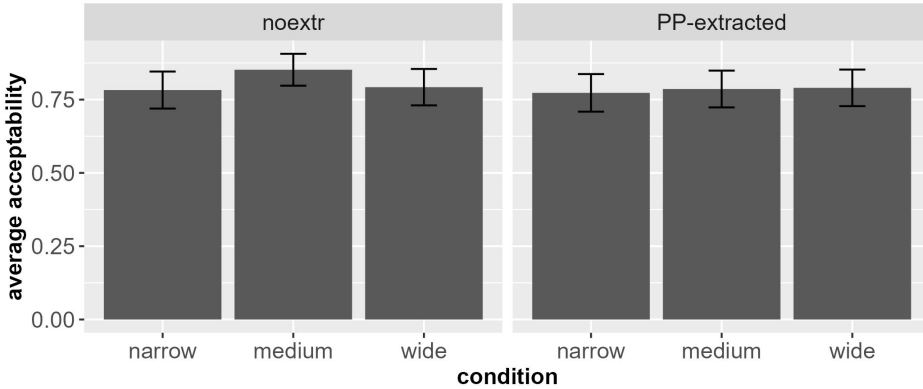

Figure 8.12: Mean acceptability judgments (in percentage) by condition of Experiment 2.

The fail rate is relatively similar across conditions: participants failed to answer in time in less than 5% of the cases, as shown in Figure 8.13. The lowest fail rate (1%) was found in extraction out of the subject (8.23a).

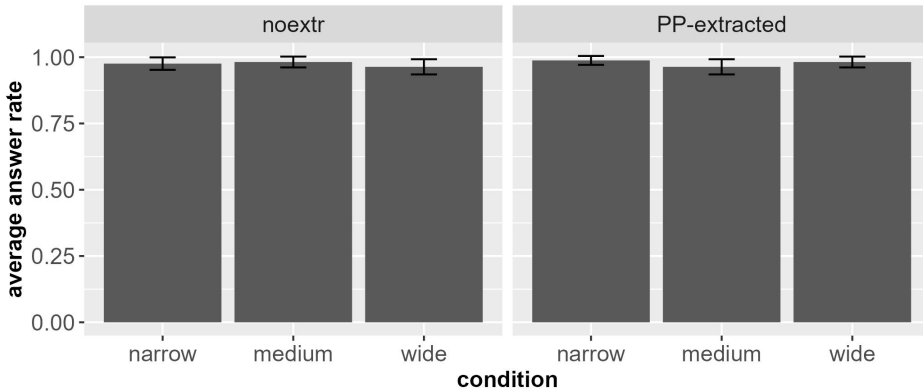

Figure 8.13: Mean answer rate by condition of Experiment 2. Non-answers are NA, i.e. participants failed to answer in time.

### 8.3.6.1 Logistic regression models

Unlike acceptability judgments on a Likert scale, the data from this experiment are binary. In order to predict a binary variable, we ran logistic regression models, using the `glm()` function under R (R Core Team 2018). One prerequisite is the validity of the Gaussian model for the data: it is generally assumed that the regression model is valid if and only if the number of data points is at least 5 times the number of explanatory variables, and the residuals are normally distributed. For all models, we validated the model by performing a residual diagnostic using the R package DHARMA (Hartig 2019). We only considered the model valid and report it in this work if the residual diagnostic is compelling.

As in the Cumulative Link Mixed Models (see page 147), I include random slopes for all fixed effects grouped by participants and items whenever convergence was achievable, and fit a non-maximal model otherwise.

### 8.3.6.2 Habituation

The habituation effects in the course of the experiment are depicted in Figure 8.14. Recall that in Experiment 1, the two extractions out of the object show a “reversed” habituation, with a decline in acceptability in the course of the experiment (especially the medium condition), which however was not significant. For Experiment 2, the results are very different, because the medium-distance conditions (with and without extraction) display strong habituation. The habituation pattern of the narrow-distance conditions is particularly striking: whereas habituation is small in the non-extraction condition, it seems much stronger in the subextraction condition.

We fitted a first model to compare the subject conditions (narrow-distance) on their own (mean centered with subextraction coded positive, no extraction coded negative) crossing extraction type with trial number. We included participants and items as random variables. The results of the model are reported in Table 8.11. There is no significant main effect or interaction effect: the difference in habituation seen in Figure 8.14 is not significant.<sup>14</sup>

---

<sup>14</sup>Additional models that I do not report here show that there is a significant interaction between syntactic function (distance) and trial number when we compare the narrow-distance and the wide-distance subextraction condition ( $p < .05$ ), but not when we compare the medium-distance and the wide-distance subextraction condition. This corroborates the idea that extractions out of the subject show habituation effects (Chaves & Dery 2019).

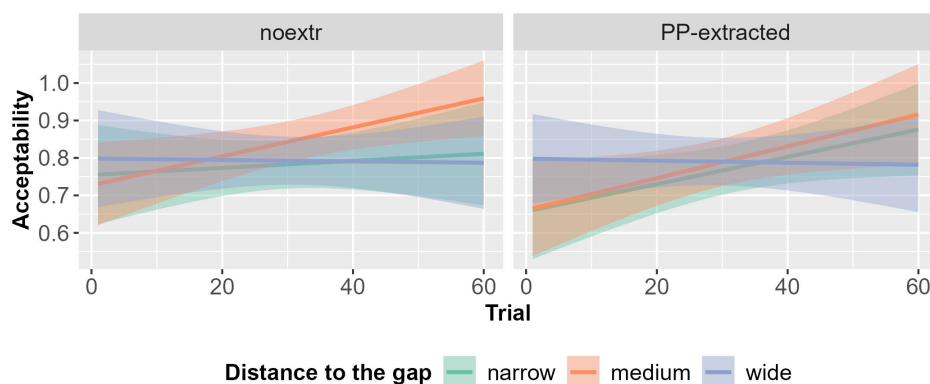

Figure 8.14: Changes in the average acceptability for each condition of Experiment 2 in the course of the experiment.

Table 8.11: Results of the Logistic regression model (model n°1)

	Estimate	SE	$z$	$\Pr(>  z )$	Odd.ratio
(Intercept)	1.124	0.384	3	<0.005	3.08
extraction type	-0.334	0.311	-1	0.2825	1.40
trial	0.016	0.009	2	0.0844	1.02
extraction type:trial	0.010	0.009	1	0.3003	1.01

### 8.3.6.3 Comparing the narrow-distance condition with the wide-distance condition

We fitted a second model to compare the extractions out of the subject and out of the object on their own (mean centered with subject coded negative and object coded positive). Trial number was included as a covariate, and participants and items as random variables. The results of the model are reported in Table 8.12. There is a significant main effect of trial (habituation), but no main effect of syntactic function.

A third model crossed distance and extraction type (mean centered with extraction coded positive, non-extraction coded negative). We included trial number as a covariate, and participants and items as random variables. The results of the model are reported in Table 8.13. There is no significant main effect, and no interaction effect. The interaction is shown in Figure 8.15 and indeed all conditions seem to have a similar acceptability rate.

8 Empirical data on dont relative clauses

Table 8.12: Results of the Logistic regression model (model n°2)

	Estimate	SE	z	Pr(>  z )	Odd.ratio
(Intercept)	1.127	0.239	5	<0.001	3.09
syntactic function	0.044	0.091	0	0.6283	1.04
trial	0.012	0.005	2	<0.05	1.01

Table 8.13: Results of the Logistic regression model (model n°3)

	Estimate	SE	z	Pr(>  z )	Odd.ratio
(Intercept)	1.293	0.270	5	<0.001	3.65
syntactic function	0.046	0.102	0	0.6531	1.05
extraction type	-0.020	0.101	0	0.8433	1.02
Trial	0.008	0.006	1	0.2006	1.01
syntactic function:extraction type	0.020	0.102	0	0.8432	1.02

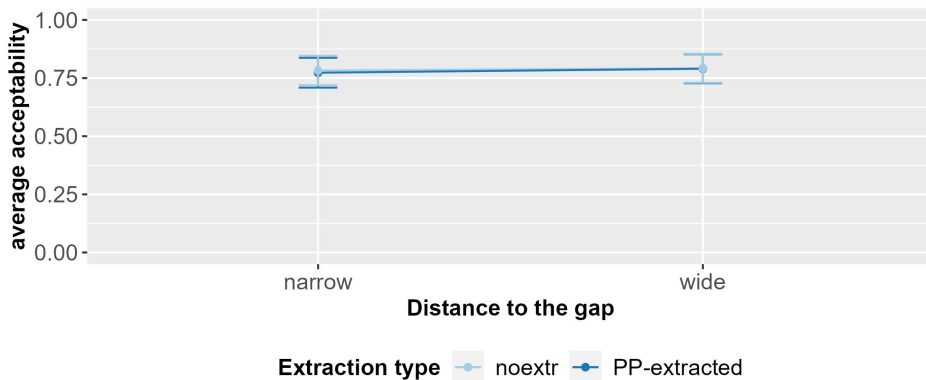

Figure 8.15: Interaction between distance and extraction type in Experiment 2. The graph only shows the narrow-distance and wide-distance conditions.



### 8.3.6.4 Comparing the narrow-distance condition with the medium-distance condition

We fitted a fourth model to compare the extractions out of the subject and out of the object on their own (mean centered with subject coded negative and object coded positive). Trial number was included as a covariate, and participants and items as random variables. The results of the model are reported in Table 8.14. There is a main effect of habituation (trial), but no significant difference between subject and object.

Table 8.14: Results of the Logistic regression model (model n°4)

	Estimate	SE	$z$	$\text{Pr}( >  z  )$	Odd.ratio
(Intercept)	0.990	0.215	5	<0.001	2.69
syntactic function	0.113	0.092	1	0.2193	1.12
Trial	0.017	0.005	3	<0.005	1.02

A fifth model crossed distance and extraction type (mean centered with extraction coded positive, non-extraction coded negative). As in the previous analyses, we included trial number as a covariate, and participants and items as random variables. The results of the model are reported in Table 8.15. There is again a main effect of habituation (trial), but no other main effect, and no interaction effect. The interaction is shown in Figure 8.16: there is a slight tendency toward a penalty for extracting out of the object (medium-distance), but it is not significant.

Table 8.15: Results of the Logistic regression model (model n°5)

	Estimate	SE	$z$	$\text{Pr}( >  z  )$	Odd.ratio
(Intercept)	0.866	0.233	4	<0.001	2.38
extraction type	-0.142	0.103	-1	0.1683	1.15
syntactic function	0.142	0.103	1	0.1676	1.15
trial	0.022	0.006	4	<0.001	1.02
extraction type:syntactic function	-0.086	0.103	-1	0.4049	1.09

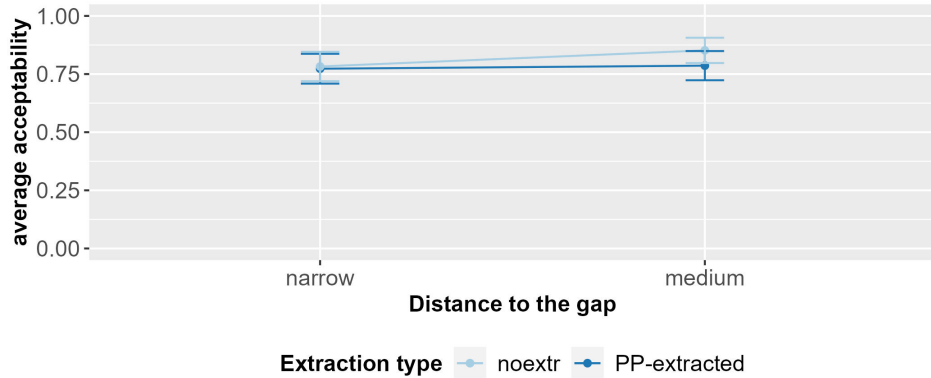

Figure 8.16: Interaction between distance and extraction type in Experiment 2. The graph only shows the narrow-distance and medium-distance conditions.

### 8.3.6.5 Comparing the medium-distance condition with the wide-distance condition

We fitted a sixth model to compare the extractions out of the object with a clitic subject and with a nominal subject on their own (mean centered with clitic subject coded negative and nominal subject coded positive). We included trial number as a covariate, and random slopes for all fixed effects and covariates grouped by participants and items. The results of the model are reported in Table 8.16. There is a main effect of habituation (trial) but the difference between subject and object is not significant.

Table 8.16: Results of the Logistic regression model (model n°6)

	Estimate	SE	$z$	$\Pr(>  z )$	Odd.ratio
(Intercept)	1.053	0.233	5	<0.001	2.87
syntactic function	0.112	0.093	1	0.2277	1.12
trial	0.017	0.005	3	<0.005	1.02

The last model crossed distance and extraction type (mean centered with extraction coded positive, non-extraction coded negative). We included trial number as a covariate, and random slopes for all fixed effects and covariates grouped by participants and items. The results of the model are reported in Table 8.17. As in model n°5, there is a significant main effect of habituation (trial), but no

Table 8.17: Results of the Logistic regression model (model n°7)

	Estimate	SE	$z$	$\Pr(>  z )$	Odd.ratio
(Intercept)	1.231	0.261	5	<0.001	3.43
extraction type	-0.119	0.105	-1	0.2556	1.13
syntactic function	0.106	0.105	1	0.312	1.11
trial	0.014	0.006	2	<0.05	1.01
extraction type:syntactic function	-0.124	0.105	-1	0.238	1.13

other significant main effect or interaction effect. The interaction is shown in Figure 8.17: there is again a slight tendency toward a penalty for extracting out of the medium-distance object, but it is not significant.

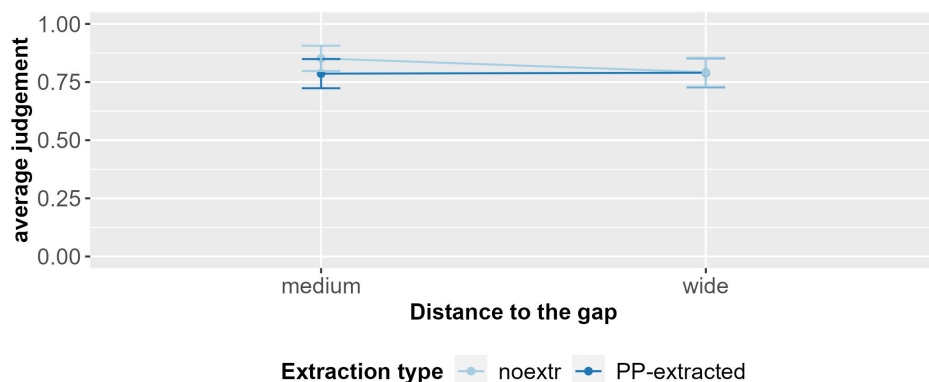

Figure 8.17: Interaction between distance and extraction type in Experiment 2. The graph only shows the medium-distance and wide-distance conditions.

### 8.3.7 Discussion

Thanks to the speeded nature of the task, we managed to reduce the ceiling effects that we observed in Experiment 1. Unfortunately, all we see in the results are null effects that do not allow us to falsify any predictions. The results of Experiment 2 are overall compatible with any account of extraction out of NPs. In light of Experiment 2, we might even consider the possibility that the advantage for extractions out of the subject in Experiment 1 is an artefact of the ceiling effects.

Nevertheless, the absence of any strong degradation when extracting out of subjects raises suspicion against a syntactic approach, in which clear and categorical judgments are expected: if extraction out of the subject is ruled out by grammar, we expect participants to reject it strongly, and not to accept this type of subextraction in 77% of the cases.

The habituation patterns in Figure 8.14 are compatible with Chaves & Dery's (2014) conclusions. According to them, extractions out of the subject become better over time, but the effects can only be seen after enough exposure to the structure, and our experiment does not have enough items for habituation to be a significant factor. However, this is not compatible with the FBC constraint, because it predicts no special behavior with extractions out of subjects in relative clauses.

## 8.4 Experiment 3: Eye tracking study on *dont* relative clauses with different linear distances

In this experiment, we tested the materials from Experiments 1 and 2 with another experimental method: eye tracking. Eye tracking is a useful method to identify processing difficulties (see Section 8.4.2 below).

### 8.4.1 Design and materials

In this eye tracking experiment, the whole sentence appeared on the screen and participants had to read it before going on to the next sentence. Therefore, we defined regions of interest on the sentence and measured fixations, i.e. the time the participants' eyes stayed on each region. Reading times on the first region are not very informative because they reflect not only the actual reading but also the reaction time to the beginning of the reading task, as well as potential correction of fixations for the beginning of the line. Therefore, reading times in this region cannot be compared to reading times of other regions. The last region also is not very informative, because reading times will be long regardless of the material presented in the region – this is known as the wrap-up effect (Rayner et al. 1995). We therefore want to define regions of interest in such a way that the first and last regions are not relevant for the outcome of the experiment.

In our case, we wanted to compare the reading times for subjects with a gap to the reading times for objects with a gap. For this reason, we used the same stimuli as in Experiment 1, but introduced some material after the direct object, resulting in sentences such as the following (square brackets indicate regions for explanatory purposes, but there was no indication of regions on the screen):

- (8.25) a. Condition narrow-distance + PP-extracted:  
 [Ils présentent une innovation]<sub>1</sub> [dont]<sub>2</sub> [l' originalité]<sub>3</sub>  
 they present an innovation of.which the uniqueness  
 [émerveille]<sub>4</sub> [mes collègues]<sub>5</sub> [sans aucune raison]<sub>6</sub>.  
 delights my colleagues without any reason  
 'They present an innovation of which the uniqueness delights my  
 colleagues for no reason.'
- b. Condition medium-distance + PP-extracted:  
 [Ils présentent une innovation]<sub>1</sub> [dont]<sub>2</sub> [nous]<sub>3</sub>  
 they present an innovation of.which we  
 [appréciations]<sub>4</sub> [l' originalité]<sub>5</sub> [sans aucune raison]<sub>6</sub>.  
 value the uniqueness without any reason  
 'They present an innovation of which we value the uniqueness  
 for no reason.'
- c. Condition wide-distance + PP-extracted:  
 [Ils présentent une innovation]<sub>1</sub> [dont]<sub>2</sub> [mes collègues]<sub>3</sub>  
 they present an innovation of.which my colleagues  
 [apprécient]<sub>4</sub> [l' originalité]<sub>5</sub> [sans aucune raison]<sub>6</sub>.  
 value the uniqueness without any reason  
 'They present an innovation of which my colleagues value the  
 uniqueness for no reason.'
- (8.26) a. Condition narrow-distance + noextr:  
 [Ils présentent une innovation]<sub>1</sub> [et]<sub>2</sub> [son originalité]<sub>3</sub>  
 they present an innovation and its uniqueness  
 [émerveille]<sub>4</sub> [mes collègues]<sub>5</sub> [sans aucune raison]<sub>6</sub>.  
 delights my colleagues without any reason  
 'They present an innovation and its uniqueness delights my  
 colleagues for no reason.'
- b. Condition medium-distance + noextr:  
 [Ils présentent une innovation]<sub>1</sub> [et]<sub>2</sub> [nous]<sub>3</sub> [appréciations]<sub>4</sub>  
 they present an innovation and we value  
 [son originalité]<sub>5</sub> [sans aucune raison]<sub>6</sub>.  
 its uniqueness without any reason  
 'They present an innovation and we value its uniqueness for no  
 reason.'

- c. Condition wide-distance + noextr:  
[Ils présentent une innovation]<sub>1</sub> [et]<sub>2</sub> [mes collègues]<sub>3</sub>  
they present an innovation and my colleagues  
[apprécient]<sub>4</sub> [son originalité]<sub>5</sub> [sans aucune raison]<sub>6</sub>.  
value its uniqueness without any reason  
'They present an innovation and my colleagues value its  
uniqueness for no reason.'

We tested 30 items, each appearing in the six conditions already described. One item was excluded from the results because of a typo in one of the conditions. In addition, the experiment included 32 distractors.

#### 8.4.2 Experimental method

Unlike standard acceptability judgment tasks, which record offline measures, eye tracking (as well as self-paced reading, a method used in Experiment 9) provides online measures that are assumed to reflect the ongoing processing of sentences. This assumption is based on the eye-mind hypothesis (Just & Carpenter 1980), namely that readers look at the area on the screen currently processed. Under this hypothesis, longer reading times reflect higher processing difficulties (Staub & Rayner 2007; Conklin et al. 2018: 65).

In an eye tracking study, participants typically face a screen with visual stimuli, while their eye movements are recorded by the eye tracking device (Conklin et al. 2018: 33–35). In our case, the stimuli were static, and the participant's task was to read one sentence at a time.

The eye-tracker records fixations and saccades of the participant's eye. While early measures such as first fixation duration usually reflect the reader's lexical access to the words in the critical region, intermediate and late measures such as regression path or second pass reading times are more likely to reflect processing difficulties linked to discourse or contextual factors (Conklin et al. 2018: Section 3.2.1). However, syntactic processing difficulties can be reflected by virtually any of these measures (Clifton et al. 2007; Conklin et al. 2018: 90). Here is a list of the different measures that were used in the present experiment:

*First fixation duration:* The first fixation is the first time a fixation is recorded inside the critical region. It does not include the duration of another fixation inside the same region, not even a second fixation inside the region without any saccade outside the region between the two.

The first fixation is usually associated with lexical retrieval, but it is also

relevant in the so-called spillover region, i.e. the region after the critical region. Spillover effects occur when processing difficulties in one region induce an increase in reading time in the following region. The reader may for example look forward in the sentence to find some piece of information that may help the processing of the critical region.

*Regression path duration:* “Regression” refers to the whole time spent between the first fixation inside the critical region and the first recorded fixation on a region to the right. Therefore, it may include several saccades and fixations backward to the left of the critical region. It is a good indicator of syntactic or pragmatic difficulties. For example, the reader may need to go back to a previous region in order to confirm that they correctly interpreted previous words, or to correct a false interpretation. I also looked at regression path duration in the spillover region in order to identify potential spillover effects.

*Regression out:* the number of backward regressions from the critical region to previous regions in the sentence.

*Regression in:* the number of backward regressions to the critical region from a later region in the sentence.

*Total reading time:* the sum of all fixation durations in the critical region.

The experiment was designed to isolate the two factors of interest: linear distance of the dependency and extraction type. In addition, the length (= number of characters) of the regions 3 and 5 was kept equal as much as possible for nominal NPs, and was included in the models as explanatory factors. Another factor that can impact reading time on a word is participants’ familiarity with the word; familiar words are typically read faster than unfamiliar words. For this reason, we also took into account word frequency as explanatory variable. We assigned a frequency value to the region 3, 4 and 5 based on the frequency of the head noun for region 4 and 6, and on the frequency of the verb for region 5. These values were taken from [lexique.org](http://lexique.org).<sup>15</sup> Of course corpus frequencies are only an approximation of the participant’s familiarity with a certain word, but they are a good predictor for the influence of lexical access on reading times (Rayner & Duffy 1986). Finally, the predictability of a word also affects its reading time (Ehrlich & Rayner 1981). We relied on our intuition that relational nouns were all equally

---

<sup>15</sup>The Lexique database was implemented by Boris New and Christophe Pallier. We used the frequency of the lemma, called `freqlemfilm2` and based on the frequency in French subtitles.

predictable and plausible in the test items, but did not perform a pretest to control for this factor.

### 8.4.3 Predictions

As in Experiment 1 and Experiment 2, the aim of this experiment was to compare the predictions of the traditional syntactic account with the predictions of a processing account based on memory load.

#### 8.4.3.1 Subject (region 3)

Focusing on the subject region, the pre-critical region is region 2 (the conjunction or the relative word), and the spillover region is region 4. We can only compare condition (8.25a) with condition (8.25c), since (8.25b) is too short.

Accounts that treat subjects as islands predict processing difficulties when integrating the gap with the subject. This difficulty may be reflected on the subject itself, but it is more likely to create a spillover effect on the next region (the verb). We therefore examined regression path durations on region 3 and first fixation and regression path durations on region 4. These measures should be longer for (8.25a) than for the other conditions. If we assume that the gap inside the subject is unexpected, then we should see a higher rate of regression out for extractions out of the subject (8.25a) (e.g., the reader going back to the relative word to check its requirement for a *de*-PP). For the same reason, we also expect more regressions in (e.g., once readers reach the object and realize that the gap is filled by the possessive article, they go back to the subject to check its compatibility with a gap).

A processing account based on memory costs predicts the exact opposite. Under such an account, the reader is more likely to posit a gap inside the subject than at any other site. Reading times should then be shorter for subextraction out of the subject, and filled-gap effects should occur in subextraction out of the object. Regression path durations on region 3 as well as first fixation and regression path durations on region 4 are therefore expected to be longer for extraction out of the object (8.25a) than in the other conditions.

Notice however that some scholars, like Yoshida et al. (2014), take even a decrease in reading time on the subject in extractions out of the subject to be compatible with the subject island hypothesis. They argue that a gap is never posited in the subject, because that would be ungrammatical. Therefore, the reader “gives up” on integrating the filler. There are reasons to suspect that this is a post hoc explanation which was proposed to deal with a decrease of reading times in their



data. More importantly, I judge this argumentation more adequate for self-paced reading than for eye tracking – and, indeed, Yoshida et al. (2014) apply the explanation to results from self-paced reading. In my opinion, as far as the reader is able to go back and try to make sense of the sentence during an eye tracking experiment, they will do so before “giving up”. Hence, I put this line of explanation aside for the present experiment, even though it casts doubt on the predictions of traditional syntactic accounts that I just described. I will consider the “giving up” scenario in Experiment 9.

#### 8.4.3.2 Object (region 5)

Focusing on the object region, the pre-critical region is region 4 (the verb), and the spillover region is region 6. Unfortunately, in this configuration, the spillover region is also the last region, and potential wrap-up effects may interfere with identifying spillover effects. Another potentially interesting pre-critical region is region 3 (the conjunction or the relative word).

We can first compare condition (8.25a) with condition (8.25c). Assuming that subjects are islands, we expect longer regression path durations and more regressions out in subextraction out of the subject: the reader realizes that the expected gap is filled by the possessive article and goes back in order to reanalyze the relative. Overall, there should also be longer total reading times on regions 3+4+5 in this condition.

By contrast, if we assume that shorter dependency lengths are easier to process and that subjects are not islands, then we expect longer regression path durations for subextraction out of the object. Furthermore, we also expect longer total reading times on regions 3+4+5 in this condition.

We can also compare conditions (8.25c) with conditions (8.25b). The subject island approach does not make any predictions for different extractions out of the object.<sup>16</sup> The DLT, on the other hand, predicts less processing difficulty when the subject is a clitic, consequently, regression path durations should be longer in (8.25c), and there should be more regressions out in this region, e.g. the reader going back to the relative word.

#### 8.4.3.3 Relative word (region 2)

It is also interesting to look at regressions in for the relative word. In general, we expect a higher rate in the extraction conditions than in the coordination

---

<sup>16</sup>Relativized minimality probably does because of the intervening subject NP in (8.25c), but for reasons that are orthogonal to the subject island discussion.

conditions, because it should be more necessary to check the form of the relative word. The syntactic accounts predict that extractions out of the subject trigger more regressions in than the other conditions. The processing accounts predict a gradation such that less regression in should be observed in condition (8.25a) than in condition (8.25b), which in turn should be less than in condition (8.25c).

#### 8.4.4 Procedure

The experiment was conducted in the eye tracking lab of the Laboratoire de Linguistique Formelle (LLF) in the Université Paris Cité. The investigators were Céline Pozniak, Aoi Shiraishi and myself. The experiment was run on Eyelink II and recorded the participant's dominant eye (following Miles's 1930 test). Testing was done individually.

The participants received written instructions and gave informed consent. Before the actual experiment, participants provided information on their linguistic background. These information forms were treated anonymously during data processing.

Sentences were presented one at a time on a computer screen and participants were instructed to read them as fast as possible while maintaining comprehension. They would then press a button to proceed to the following sentence. In some trials, a comprehension question would appear on the screen related to the sentence just read. Participants responded to it by choosing one of two possible answers on the screen. We used a Latin square design, such that each participant saw each item and distractor in only one condition.

After an initial calibration phase, participants first went through a practice block of three sentences and had the opportunity to ask questions. Then the investigator would leave the room and the experimental items and distractors were presented in three blocks. Each block began with a short calibration phase. Participants could take a break between the blocks as needed. The experiment lasted approximately one hour. At the end, participants were debriefed and they received a payment of 10€.

#### 8.4.5 Participants

The study was conducted in July 2016. 32 participants took part in the experiment. They were recruited on the R.I.S.C. website (<http://experiences.risc.cnrs.fr/>) and on social media (e.g. Facebook).

One of them turned out to be bilingual and was excluded from the analysis. The data presented here come from the remaining 31 participants. Their age ranged

from 18 to 57 years. None of them had any educational background or occupation related to language.

### 8.4.6 Results and analysis

Reaction times typically have a non-normal distribution with a very long tail for longer reaction times. For this reason, following the usual methodology in reading time studies, the results presented here are based on log-transformed reading times, whose distribution is closer to normal. The results in ms are log-transformed using the function  $\log()$  under R (R Core Team 2018).

I suppressed data for skipped regions, i.e. regions with no fixation at all. Outliers, i.e. measurements that were more than 3 standard deviations away from each participant's mean for a given region in a given condition, were eliminated.

Figure 8.18 shows the total reading times, and Figure 8.19 shows the regression path durations on the experimental items.

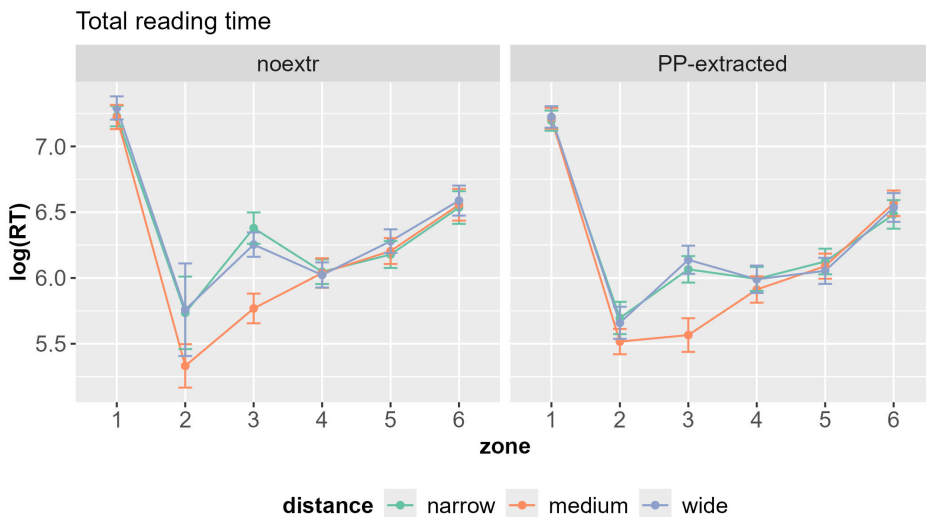

Figure 8.18: Region means and 95% confidence intervals for the log-transformed total reading time of all conditions in Experiment 3 (Regions = 1: Matrix clause; 2: Relative word/conjunction; 3: Subject; 4: Verb; 5: Object; 6: AdvP)

Linear Mixed-Effects Models: Log-transformed reaction times can be considered a continuous variable. To see how well a set of explanatory variables predicts a (continuous) variable  $A$ , we ran Linear Mixed-Effects Models, using the

## 8 Empirical data on dont relative clauses

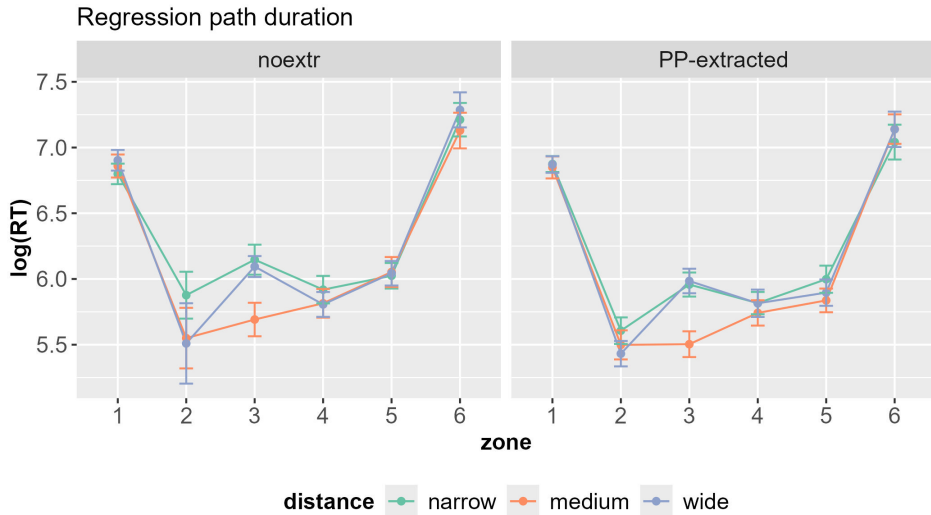

Figure 8.19: Region means and 95% confidence intervals for the log-transformed regression path duration of all conditions in Experiment 3 (Regions = 1: Matrix clause; 2: Relative word/conjunction; 3: Subject; 4: Verb; 5: Object; 6: AdvP)

lmer() function under R (R Core Team 2018). One prerequisite for Linear models is that the Gaussian model must be valid for the variable A. I performed a visual inspection of the residuals using the function qqnorm() from the R Stats Package (R Core Team 2018), and only report the results of the models if the residuals diagnostic is compelling. As in the Cumulative Link Mixed Models (see page 147), I included random slopes for all fixed effects grouped by participants and items whenever convergence was achievable, and fitted a non-maximal model otherwise.

In order to test every prediction listed in Section 8.4.3 above, it was necessary to run several mixed models. The interested reader is referred to Appendix E, in which every step of the statistical analysis is described in detail. In the present section, I only highlight the main findings relative to the predictions. Appendix E also provides more figures that illustrate the results.

Table 8.18 summarizes the results of all models.<sup>17</sup> All models include participants and items as random variables. We ran maximal models whenever possible, and added length (number of characters) and frequency as covariates whenever possible (it was sometimes necessary to drop either length or frequency because

<sup>17</sup>Notice that model n°14 is missing, because it did not converge, cf. Appendix E.

of singularities in the model). Notice that the results must be taken with caution, because we computed a large number of models and did not correct the confidence level for multiple comparisons.

There is usually no significant main effect of distance in the models, except when we compare the regression path durations at extraction sites (results for region 3 in the subject conditions and for region 5 in the object conditions) in model n°15. Indeed, as illustrated by Figure 8.20, the subject conditions have longer reading times. This is not surprising given that region 3 appears to the left of region 5. There is however no significant interaction effect between distance and extraction type in model n°15.

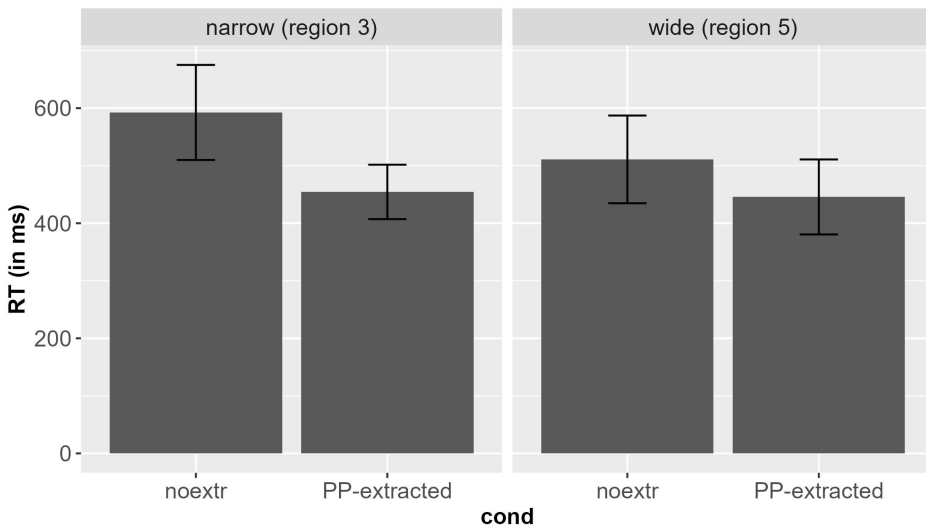

Figure 8.20: Regression path durations for region 3 (subject) on the one hand and region 5 (object) on the other hand in Experiment 3 with 95% confidence intervals.

In the models, we often observe a significant main effect of extraction type. In each of these cases, the non-extraction conditions lead to longer reading times, more regressions in or more regressions out than the subextraction conditions. This is also clearly visible in Figure 8.20, as well as Figure 8.21.

The most interesting effect for the predictions in Section 8.4.3 is the interaction between distance and extraction type. There is no evidence from the data that regression path durations are longer on the subject (model N°2) or the object (model n°9) when there is extraction out of the subject – nor is there evidence to the contrary. There is also no indication that there are more regressions out from

Table 8.18: Results with  $p$  values of the models. dist: distance; extr: extraction type; "Max?" indicates whether the model is maximal.

Model	Dependent variable	Fixed effects			Covariate		Max?
		dist.	extr.	dist.:extr.	length	frequ.	
n°1	total reading time on region 3+4+5	0.1213	<0.05	0.5741	<0.001		yes
n°2	regression path duration on region 3	0.9238	<0.01	0.4538	<0.005	0.8217	yes
n°3	regression out on region 3	0.9906	0.7051	0.1673	<0.005	0.1890	no
n°4	amount of regression out on region 3	0.8411	0.996	0.4062	<0.01		no
n°5	regression in on region 3	0.2928	<0.05	<0.005	0.7446		no
n°6	amount of regression in on region 3	0.2051	<0.01	<0.005	0.5040		no
n°7	first fixation duration on region 4	0.4151	0.4713	0.2937	0.5205	0.1397	no
n°8	regression path duration on region 4	0.3118	0.1545	0.0585	0.2921	0.1356	no
n°9	regression path duration on region 5	0.1482	0.1038	0.4454	0.0536	0.2014	no
n°10	regression out on region 5	0.4724	0.4600	0.2344	0.5704		no
n°11	amount of regression out on region 5	0.6853	0.4875	0.7646	0.1805		no
n°12	regression path duration on region 5	0.0934	<0.01	0.0677	<0.01	0.8521	no
n°13	regression out on region 5	0.1147	<0.05	0.4702	0.1396		no
n°15	regression path duration on extraction site	<0.05	<0.005	0.3036	<0.005	<0.05	no
n°16	regression in on region 2	0.7502				0.7668	no
n°17	regression in on region 2	0.6061				0.2283	yes
n°18	regression in on region 2	0.0682				0.6732	no
n°19	amount of regression in on region 2	0.3377	0.4641	0.7308		0.6652	no
n°20	amount of regression in on region 2	0.6888	0.7167	0.6466	0.6044	0.2536	yes
n°21	amount of regression in on region 2	0.1288	0.4496	0.4508	0.3650		no

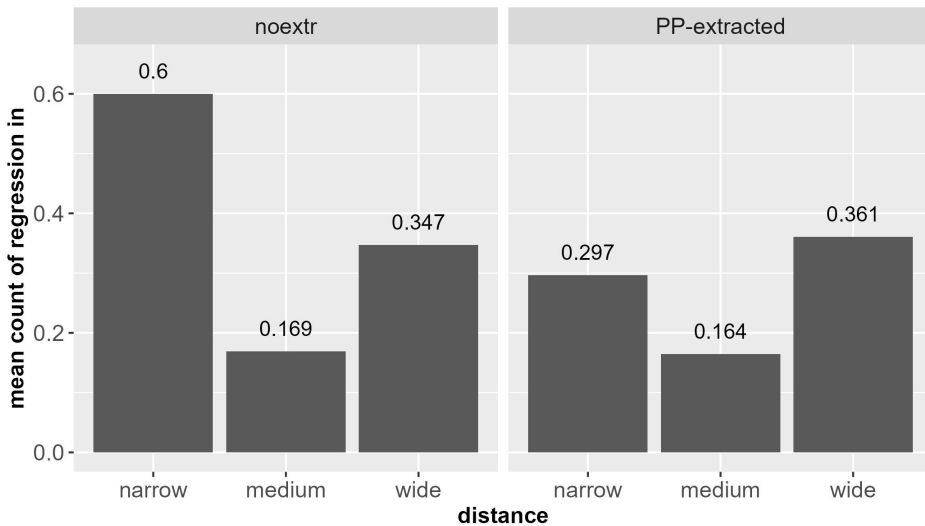

Figure 8.21: Mean amount of regression in in Region 3 in Experiment 3

the subject or from the object potentially due to the need to re-read the filler or the antecedent (models n°3 and n°4 for subject, models n°10 and n°11 for object), nor is there an indication of the opposite. The total reading times for the whole section from subject to object of the relative clause are not longer for extractions out of the subject, nor are they longer for extractions out of the object when the distance is the highest (model n°1).

However, there is a significant interaction if we compare the narrow- and the wide-distance with respect to regressions back to the subject: extractions out of the subject generate fewer regressions in than the other conditions, as illustrated by Figure 8.21. But there do not seem to be more regressions back to the relative word (models n°16 to n°21).

There is also a small hint of a pullover effect on the verb, but the interaction effect is only marginal. Indeed, if we compare narrow- and wide-distances, regression path durations on region 4 show a small tendency such that extractions out of the subject generate shorter reading times than the other conditions (model n°8), as shown in Figure 8.22.

All the results above concern a comparison of the narrow-distance with the wide-distance conditions. None of the effects predicted by the DLT (or other processing accounts based on memory costs) were significant when comparing the narrow-distance with the medium-distance conditions (models n°16 and n°19) or

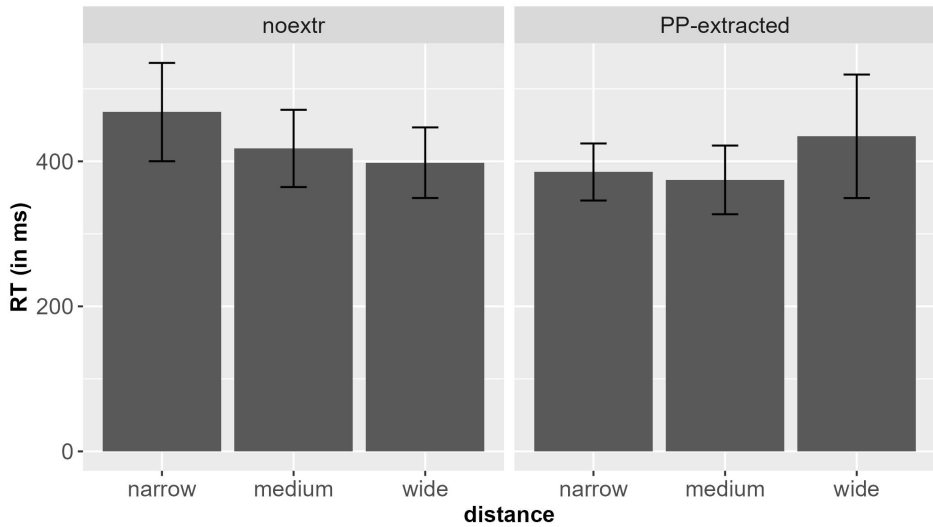

Figure 8.22: Regression path durations by condition for region 4 in Experiment 3 with 95% confidence intervals.

the medium-distance with the wide-distance conditions (models n°12, n°13, n°18 and n°21).

### 8.4.7 Discussion

Overall, we did not observe many of the expected effects described in Section 8.4.3. Whenever we found a significant interaction effect, it was in general more in line with the predictions of processing accounts based on memory costs than with the predictions of the traditional syntactic account. The increase of regressions in on the subject when there is extraction out of the object could be evidence that readers posit a gap inside the subject and need to come back to it to ensure that there is no dependency between the relative phrase and the subject. The tendency toward a spillover effect on the verb also goes in this direction: it could be caused by a filled-gap effect, in that the reader has to readjust their expectation that the gap is inside the subject.

However, based on Figure 8.21, I think that the interaction effects are caused by another factor. My impression is that the interaction effect comes from an increase of regressions in for the subject control condition. The reason can be related to what I pointed out in the discussion of the two previous experiments: *dont* relative clauses seemed to be preferred over the anaphoric possessive article.



Perhaps this possessive article is even less expected when its referent is close, as is the case in the narrow-distance non-extraction condition (there is no new referent introduced between *innovation* and *son* in (8.26a)).

The main effect of extraction type observed several times in the models seems to contradict the fact that there are additional costs associated with the integration of the gap (Momma et al. 2019). My only explanation is that such short-distance dependencies do not induce enough memory costs to slow down reading times, especially in a construction very frequently encountered by French speakers. Moreover, the control conditions also induce memory costs due to a different kind of syntactic binding. These two memory costs may cancel each other out in my experiment. As noticed by Keshev & Meltzer-Asscher (2019), experiments on cataphoric constructions display interaction effects similar to those attributed to weak islands. Since experiments on islands typically do not control for binding, at least some of the results usually attributed to islands could be caused by binding.

## 8.5 Experiment 4: Acceptability judgment study on *dont* relative clauses with long-distance dependencies

In this experiment, we tested similar stimuli but with long-distance dependencies: the *dont* relative clause contains an embedded clause, and the NP out of which extraction takes place is either subject or object of this embedded clause. For this experiment, we wanted to have a design similar to the long-distance dependencies tested by Sprouse et al. (2016) in English and Italian. Using long-distance dependencies also ensures that extractions out of the subject are “real” extractions and not a movement inside the DP as proposed by Heck (2009) (see Section 2.3.1).

### 8.5.1 Design and materials

The experiment was an acceptability judgment task with a 2\*3 design. In this experiment, we do not test three different distances between *dont* and the gap, but only compare extractions out of subjects (8.27a) with extractions out of objects (8.27b), as in Sprouse et al. (2016).

8 Empirical data on *dont* relative clauses

- (8.27) a. Condition subject + PP-extracted:  
Google présente une innovation dont<sub>i</sub> on suppose [que [l'  
Google presents an innovation of.which one suspects that the  
originalité <sub>-i</sub>] enthousiasme mes collègues sans aucune  
uniqueness excites my colleagues without any  
raison].  
reason  
'Google presents an innovation of which we suspect that the  
uniqueness excites my colleagues for no reason.'
- b. Condition object + PP-extracted:  
Google présente une innovation dont<sub>i</sub> on suppose [que mes  
Google presents an innovation of.which one suspects that my  
collègues admirent [l' originalité <sub>-i</sub>] sans aucune raison].  
colleagues admire the uniqueness without any reason  
'Google presents an innovation of which we suspect that my  
colleagues admire the uniqueness for no reason.'

Apart from these subextraction conditions, there is also a non-extraction condition (8.28) that serves as a baseline. This condition parallels the extraction one, but includes a coordination instead of a relative clause.

- (8.28) a. Condition subject + noextr:  
Google présente une innovation, et on suppose que son  
Google presents an innovation and one suspects that its  
originalité enthousiasme mes collègues sans aucune raison.  
uniqueness excites my colleagues without any reason  
'Google presents an innovation, and we suspect that its  
uniqueness excites my colleagues for no reason.'
- b. Condition object + noextr:  
Google présente une innovation, et on suppose que mes  
Google presents an innovation and one suspects that my  
collègues admirent son originalité sans aucune raison.  
colleagues admire its uniqueness without any reason  
'Google presents an innovation, and we suspect that my  
colleagues admire its uniqueness for no reason.'

These two extraction types are very similar to the design in Sprouse et al. (2016). We also included a third extraction type: the relative word *que* instead

of *dont*. Like *dont*, *que* is a complementizer, but it is used to extract direct NP objects instead of *de*-PPs. Therefore, the sentences are ungrammatical, and serve as a baseline for low judgments. Notice that the switch from *dont* to *que* is relatively frequent in informal French, but strongly stigmatized as “bad” French. It is therefore not a control with a strong ungrammaticality, but is nevertheless a good low baseline for a reading task.

- (8.29) a. Condition subject + ungramm:  
 Google présente une innovation qu’ on suppose que l’  
 Google presents an innovation that one suspects that the  
 originalité enthousiasme mes collègues sans aucune raison.  
 uniqueness excites my colleagues without any reason  
 ‘Google presents an innovation that we suspect that the  
 uniqueness excites my colleagues for no reason.’
- b. Condition object + ungramm:  
 Google présente une innovation qu’ on suppose que mes  
 Google presents an innovation that one suspects that my  
 collègues admirent l’ originalité sans aucune raison.  
 colleagues admire the uniqueness without any reason  
 ‘Google presents an innovation of which we suspect that my  
 colleagues admire the uniqueness for no reason.’

The materials were very similar to the materials used in the first three experiments, but with small changes. We planned this experiment (and some of the following ones) as the French pendant to a cross-linguistic series of studies (French-English) and tried to keep the French and English materials as close to each other as possible. Since some of the items of the previous experiments did not transfer well into English, a few changes were introduced in the French materials.

As in the previous experiments, the relation between *dont* and the gap always expressed a quality (e.g. *originalité* ‘uniqueness’, *beauté* ‘beauty’). The noun out of which the extraction takes place was always inanimate. We used psych verbs that come in reversible pairs (e.g. *apprécier* ‘value’ and *émerveiller* ‘delight’), but also some transitive non-psych verbs (e.g. *commenter* ‘comment’).

We tested 24 items, each manipulated according to the six conditions already described. In addition, the experiment included 36 distractors. Half of the experimental items and distractors were followed by a comprehension question. The item presented here as an example was followed by the comprehension question

*Est-ce que les collègues ont raison d'être enthousiastes ?* ('Are the colleagues right to be enthusiastic?').

### 8.5.2 Predictions

From the different accounts presented in the first part of this work, four big different patterns of predictions emerge, which I briefly discuss here.

A traditional syntactic account predicts a superadditivity effect in extraction out of the subject. For this reason the first expectation is that the acceptability of (8.27a) will be degraded compared to (8.27b). Long-distance dependencies should be less acceptable than the non-extraction conditions because they are more difficult. Additionally an interaction effect is expected such that (8.27b) should be worse than the three non-island conditions (8.27b), (8.28a) and (8.28b). The island condition (8.27a) should not be significantly better than the ungrammatical controls (8.29a) and (8.29b), and an interaction effect is expected as well, such that the object control (8.27b) is better than these three ungrammatical conditions.

A processing account based on surprisal due to subject complexity (such as Kluender 2004) makes similar predictions. The only difference is that, even though extraction out of the subject should be degraded, it is not necessarily expected to be as bad as ungrammatical controls. Subextractions in general should be rated higher than ungrammatical controls (main effect). A discourse-based account like the one expressed by Erteschik-Shir (1973) or Goldberg (2006) makes essentially the same prediction.

A processing account based on memory costs (like Dependency Grammar or the DLT) expects extraction out of the subject (8.27a) to receive better ratings than extraction out of the object (8.27b), the distance between *dont* and the gap being longer in the latter case. When we compare the non-extraction conditions with the subextractions, an interaction effect is expected, because extraction out of the object like (8.27b) should give rise to stronger processing difficulties. But subextractions are expected to be better than the ungrammatical controls.

Our discourse-based account with the FBC constraint only predicts a main effect of extraction types; the control without extraction should be better than the extraction condition, which in turn should be better than the ungrammatical controls. The account is neutral as to whether there should be a main effect of syntactic function (subject conditions better than object conditions or inversely), but it crucially does not expect to see any significant interaction effect.

For the sake of simplicity, we can summarize these different expectations in two major predictions: some accounts predict a "subject island" effect, whereas others do not predict it, with some minor differences between the accounts.

### 8.5.3 Procedure

We conducted the experiment on the Ixex platform (Drummond 2010). The procedure used in acceptability judgment tasks is explained in Section 8.2.3. Participants had to rate the sentences on a Likert-scale from 0 to 10, 0 being labeled as “bad” and 10 being labeled as “good”.

The experiment took approximately 20 minutes to complete. The participants were recruited through FouleFactory (<https://www.foulefactory.com>) and paid 5€ for their participation. The payment was not contingent on the participants’ responses to the questions about native language or place of birth.

### 8.5.4 Participants

The study was conducted in October 2019. 57 participants took part in the experiment. We present the analysis based on the answers of the 51 participants who satisfied all inclusion criteria.<sup>18</sup> The 51 participants were 21 to 67 years old. 31 participants self-identified as women and 20 as men. None of them indicated having an educational background related to language.

### 8.5.5 Results and analysis

Figure 8.23 summarizes the results of the acceptability judgment task. In the subextraction condition, extraction out of the subject (8.27a) received a mean acceptability rating of 7.63, slightly higher than extraction out of the object (8.27b) with a mean rating of 7.42. The control conditions without extraction were judged better overall: the subject condition (8.28a) received a mean rating of 8.10, the object condition (8.28b) 7.48. The ungrammatical controls were rated low: 3.64 in the subject condition (8.29a), and 3.21 in the object condition (8.29b).

Figure 8.23 suggests potential ceiling effects on the extraction conditions and the non-extraction conditions, and a potential floor effect on the ungrammatical control. Indeed, Figure 8.24 shows indications of ceiling effects and floor effects, especially for the subject + non-extraction condition.

Another representation of the results is given by their ROC and zROC curves in Figure 8.25. There is strong discrimination between the ungrammatical baseline and the other conditions, but no strong discrimination between coordination and subextraction. The zROC curves are slightly convex, which could be the sign

---

<sup>18</sup>In addition to the five usual criteria, we excluded two participants who did not use the Likert scale appropriately. To calculate accuracy, we excluded not only the answers to comprehension questions of the practice items and ungrammatical controls like (8.29), but also to some ungrammatical distractors.

8 Empirical data on dont relative clauses

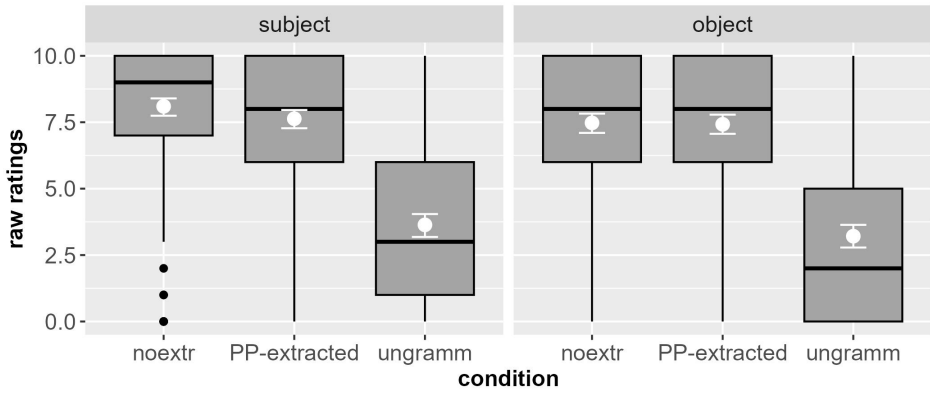

Figure 8.23: Acceptability judgments by condition in Experiment 4. The grey box plots indicate the median and quartiles of the results. Black points are outliers. Mean and confidence intervals are indicated in white.

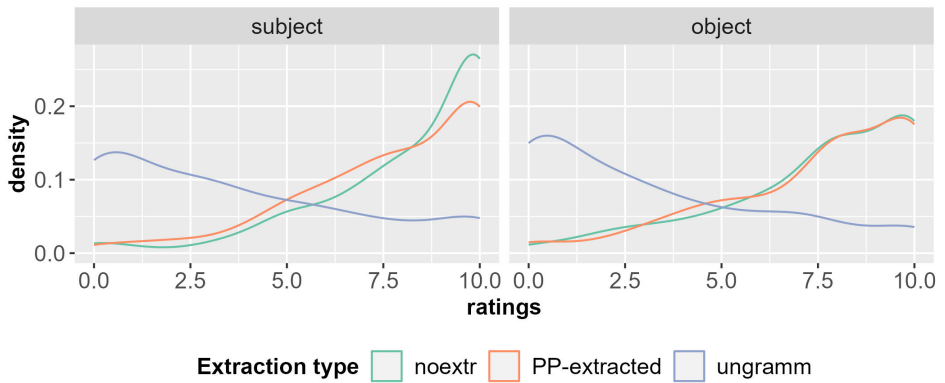

Figure 8.24: Density of the ratings across conditions for Experiment 4

for bimodality (Dillon & Wagers 2019: 21–22). This may be due to the strong habituation effect on the ungrammatical controls (see below).

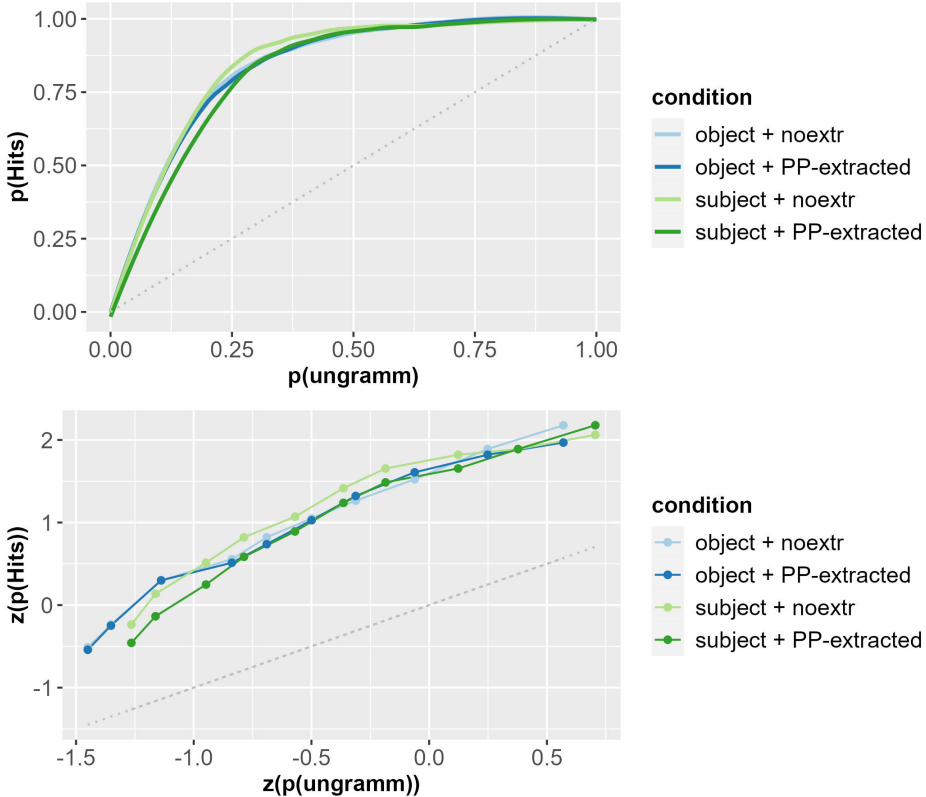

Figure 8.25: ROC curves (top) and zROC curves (bottom) of the grammatical conditions compared to their respective ungrammatical condition, represented by the dotted grey baseline (Dillon & Wagers 2019's method) in Experiment 4.

The ROC and zROC curves in Figure 8.26 illustrate the discrimination between the subject and object conditions. The ROC curves show that the participants barely discriminate between the subject and object conditions. The most important distinction is between the non-extraction and the subextraction conditions. As we show below, there is indeed a small tendency toward an interaction, but it is not significant. The zROC curves show straight lines, which is a visual cue that the distribution is normal.

## 8 Empirical data on dont relative clauses

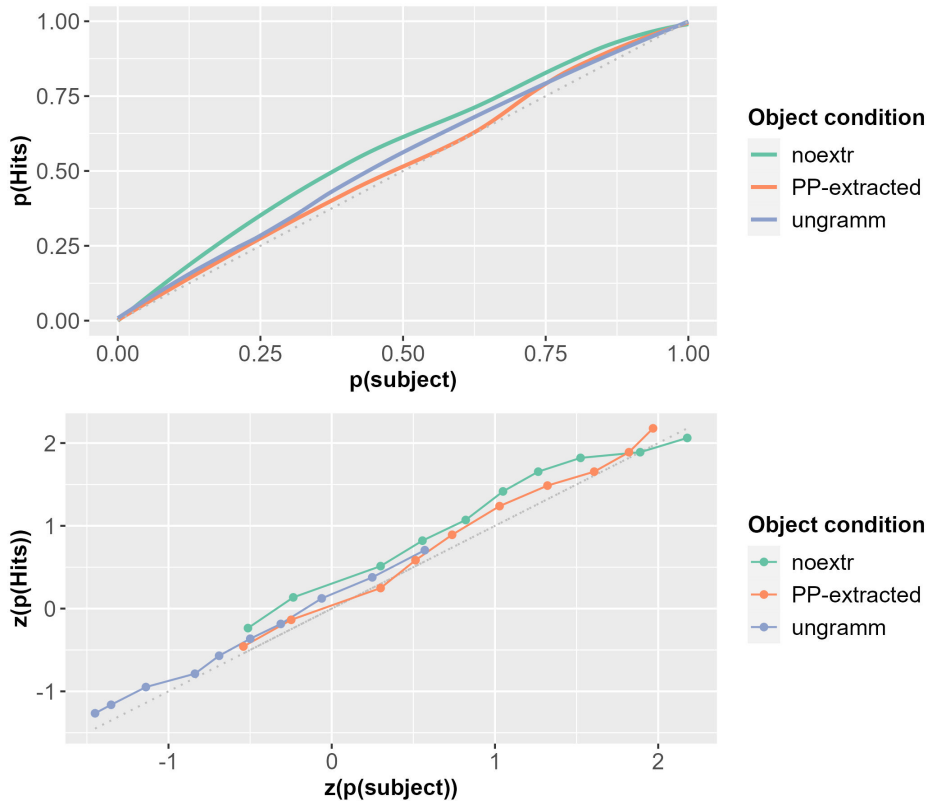

Figure 8.26: ROC curves (top) and zROC curves (bottom) of the subject conditions compared to their respective object condition, represented by the dotted grey baseline (Dillon & Wagers 2019's method) in Experiment 4.

### 8.5.5.1 Habituation

Figure 8.27 shows the habituation effects in the course of the experiment. All conditions undergo habituation during the experiment, but to different degrees. The effect is strong for the ungrammatical controls, even though the judgments remain very low until the end of the experiment. We can also see an important habituation effect for the object + non-extraction condition that I cannot explain.



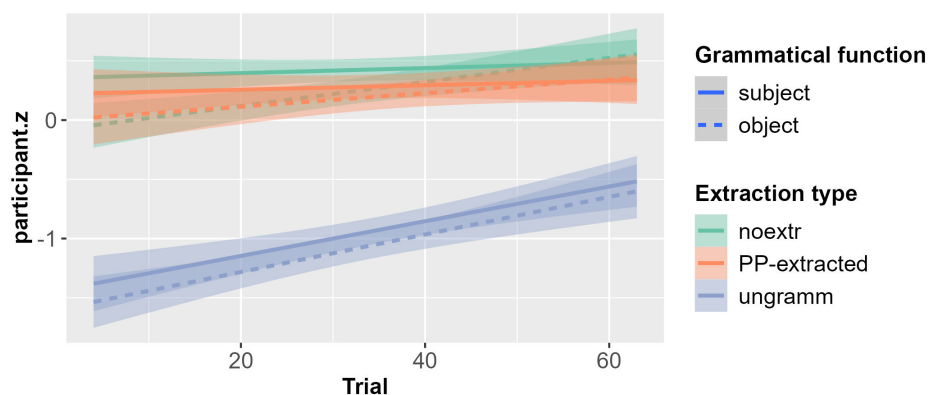

Figure 8.27: Changes in the average acceptability ratings (z-scored by participant) for each condition of Experiment 4 in the course of the experiment

### 8.5.5.2 Comparing subextraction from the subject with subextraction from the object

We fitted a first model to compare extractions out of the subject and out of the object on their own (mean centered with subject coded negative and object coded positive). We included trial number as a covariate, and random slopes for all fixed effects and covariates grouped by participants and items. The results of the model are reported in Table 8.19. There is a significant effect of the syntactic function: the subject condition received significantly higher ratings than the object condition. There is also a significant effect of trial (habituation), which corroborates the impression given by Figure 8.27.

Table 8.19: Results of the Cumulative Link Mixed Model (model n°1)

	Estimate	SE	$z$	$\Pr(>  z )$	Odd.ratio
syntactic function	-0.227	0.109	-2	<0.05	1.25
trial	0.021	0.006	4	<0.001	1.02

In a second model, we compared subextraction with non-extraction. We fitted a model crossing syntactic function and extraction type (mean centered with extraction coded positive, non-extraction coded negative). We included trial number as a covariate, and random slopes for all fixed effects grouped by participants

8 Empirical data on dont relative clauses

and items. The results of the model are reported in Table 8.20. There are significant main effects of the syntactic function (in favor of the subject condition), of extraction type (in favor of the non-extraction controls), and of trial (habituation). There is no significant interaction effect. Figure 8.28 illustrates the interaction: we see a weak tendency toward an interaction effect, but the confidence intervals overlap. Furthermore, if we compare the Area Under the Curve (AUC) for the ROC curves of the two grammatical conditions (see Figure 8.26) the difference is not significant, either.

Table 8.20: Results of the Cumulative Link Mixed Model (model n°2)

	Estimate	SE	z	Pr(>  z )	Odd.ratio
syntactic function	-0.242	0.109	-2	<0.05	1.27
extraction type	-0.191	0.087	-2	<0.05	1.21
trial	0.018	0.004	4	<0.001	1.02
syntactic function:extraction type	0.135	0.088	2	0.1223	1.14

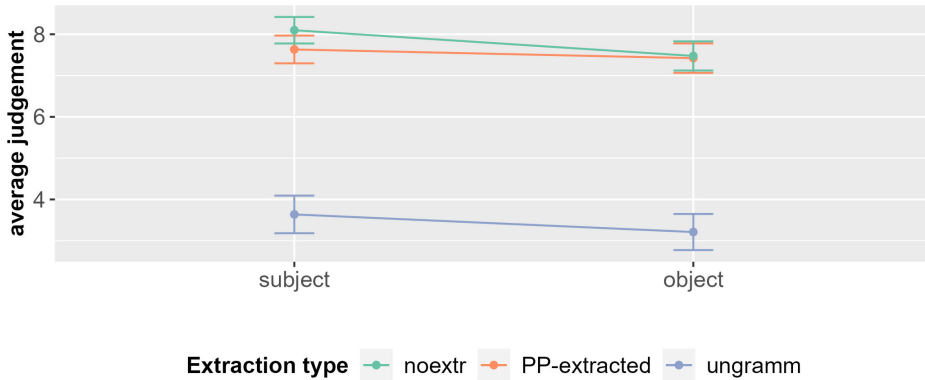

Figure 8.28: Interaction between syntactic function and extraction type in Experiment 4

A third model compared the extractions out of the subject and the ungrammatical subject condition on their own (mean centered with extraction coded negative and ungrammatical coded positive). We included trial number as a covariate, and random slopes for fixed effects and covariates grouped by participants and items. The results of the model are reported in Table 8.21. There is a significant effect of extraction type, such that the subextraction condition is better than the non-extraction condition (with a strong effect size: odds ratio = 6.58) and a significant habituation effect.

Table 8.21: Results of the Cumulative Link Mixed Model (model n°3)

	Estimate	SE	$z$	$\Pr(>  z )$	Odd.ratio
extraction type	1.884	0.223	8	<0.001	6.58
trial	0.017	0.007	2	<0.05	1.02

In a fourth model, we compared subextraction with the ungrammatical control. We fitted a model crossing syntactic function and extraction type (mean centered with extraction coded positive, ungrammatical coded negative). We included trial number as a covariate, and random slopes for all fixed effects grouped by participants and items. The results of the model are reported in Table 8.22. There are main effects of syntactic function (in favor of the subject condition), of extraction type (in favor of the subextraction, with a strong effect size: odds ratio = 6.82) and a main effect of trial (habituation), but no interaction effect (see also Figure 8.28).

Table 8.22: Results of the Cumulative Link Mixed Model (model n°4)

	Estimate	SE	$z$	$\Pr(>  z )$	Odd.ratio
syntactic function	-0.164	0.079	-2	<0.05	1.18
extraction type	1.919	0.198	10	<0.001	6.82
trial	0.020	0.004	5	<0.001	1.02
syntactic function:extraction type	0.051	0.091	1	0.5766	1.05

### 8.5.6 Discussion

The data from Experiment 4 seem similar to what we saw in Experiment 1. If we compare the results with what is expected under superadditivity, we can first notice that extractions out of the subject are significantly better than extractions out of the object (model n°1, estimate has a negative value), contrary to what is predicted. Furthermore, there is no interaction effect to corroborate the prediction (model n°2). Extraction out of subject is significantly better than its ungrammatical control (model n°3) contrary to what the traditional syntactic approach predicts, and here again there is no interaction effect (model n°4).

If we now compare the results to what is expected under accounts that do not predict a superadditivity effect, we can see that the data do not falsify the predictions. The fact that extraction out of the subject is better than extraction out of the object (model n°1) is in line with processing accounts based on memory load. However, this subject preference is present for all extraction types: syntactic function is a main effect in models n°2 and n°4, with no interaction effect. This means that extraction out of the subject is not facilitated beyond the effect observed in the baseline conditions, whereas a facilitation should be expected under a processing account based on memory costs. But we cannot rule out that the ceiling effect on the non-extraction conditions is responsible for cancelling out potential interaction effects.

The data are perfectly in line with the predictions of the FBC constraint. There is a main effect of extraction type (models n°2 and n°4), and no interaction effect, as expected. Undeniably, Experiment 4 alone does not do much to support or weaken the FBC constraint hypothesis. A recurring problem concerning relative clauses is that the FBC constraint predicts null effects. Statistical analyses can only reject a null hypothesis, never confirm it. The results of the experiments on relative clauses will gain importance, though, when we compare them with the experiments on interrogatives (Experiment 10 to 13) and on *c'est*-clefts (Experiment 14). However, we can already see at this point that all accounts that predict extractions out of the subject to be degraded compared to extractions out of the object are falsified.

## 9 Empirical data on *de qui* relative clauses

In this chapter, I present two corpus studies and five experiments. The chapter is organized as follows:

*Corpus studies on de qui:* Data from Frantext show that *de qui* relative clauses behave very similarly to *dont* relative clauses. The most common usage of *de qui* in relative clauses is extracting out of the subject. Interrogatives, however, are very different, and extraction out of the subject is not attested either in direct or indirect questions. This may indicate that there is a cross-construction difference with respect to extracting out of the subject.

*Experiment 5:* In this acceptability judgment study, we tested *de qui* relative clauses, crossing extraction type (extraction/non-extraction) with syntactic function (subject/object). The extraction takes place out of quality denoting NP (e.g. *violence* ‘violence’). Contrary to what we saw in previous experiments, extraction out of the subject received significantly lower ratings than extraction out of the object, but there is no interaction effect between extraction type and grammatical function.

*Experiment 6:* In this acceptability judgment study, we tested the material of Experiment 5 but with the relative word *dont* instead of *de qui*. We also used the same distractors. The ratings for extraction out of the subject and out of the object did not differ significantly, but the results of this experiment are questionable because we observe very strong ceiling effects.

*Experiment 7:* In this acceptability judgment study, we tested *de qui* relative clauses again, crossing extraction type (extraction/non-extraction/ungrammatical controls) with syntactic function (subject/object). Extraction took place out of NPs that denote human relations (e.g. *associé* ‘associate’). The preference for extractions out of the object observed in Experiment 5 disappeared, and extractions out of the subject were significantly better than extractions out of the object. We conclude that the significant

difference observed in Experiment 5 was due to an animacy mismatch between subject and object, and not to extraction out of the subject as such.

*Experiment 8:* In this acceptability judgment study, we tested the materials of Experiment 7 but with the relative word *dont* instead of *de qui*. Again, extractions out of the subject were judged to be significantly better than extractions out of the object.

*Experiment 9:* In this self-paced reading experiment, we investigated the online processing of *de qui* relative clauses, crossing extraction type (extraction/non-extraction/ungrammatical controls) with syntactic function (subject/object). The results do not show any obvious difficulty with extractions out of the subject. Subjects were read more quickly than objects, regardless of the extraction type. Surprisingly, we did not observe any processing cost associated with subextraction, either, which may be due to our grammatical controls, or to the experiment lacking power (e.g. not enough participants).

## 9.1 Corpus studies on *de qui*

This section summarizes the results of two corpus studies previously published in Abeillé & Winckel (2020) that looked at the distribution of occurrences of *de qui* in Frantext for texts written between 1900 and 1913, and texts written between 2000 and 2013. Unlike *dont*, *de qui* can be used not only in relative clauses but also in interrogatives.

### 9.1.1 Motivation

The main aim of this study was to find out whether *de qui* relative clauses exhibit the contrast between subextraction from the subject and subextraction from the object claimed by Tellier (1990, 1991), which Stepanov (2007) and Heck (2009) subsequently took for granted in their own analyses. Furthermore, as *de qui* is not restricted to relative clauses and *c'est*-clefts, we can look at another kind of very common extraction: interrogatives. Hence, we wanted to see whether we find any extractions out of the subject with *de qui* in these different constructions, and, if so, whether there is at least a large difference in frequency when compared to extraction out of the object. Two time periods were compared to establish if there has been a change in this usage over the last century, since we want to consider the possibility that Tellier's (1990) acceptability judgments reflect an older usage

of *de qui* and that extraction out of the subject is a rather new innovation in formal French.

Another aim was to determine if extraction out of subjects is restricted to certain verb types, as assumed by Chomsky (2008). If this were the case for *de qui* but not for *dont*, that could indicate that Chomsky is right and examples with *dont* are not real cases of subextraction but rather some kind of hanging topic (as claimed by Uriagereka 2011).

Because *de qui* appears in various filler-gap dependencies, we expect differences across constructions. Under a view of islands based on information structure, relative clauses and interrogatives should show different patterns with respect to extraction out of the subject, because the filler in a relative clause is background or topic, whereas the filler in an interrogative is more similar to a focus.

### 9.1.2 Procedure

In parallel to the two corpus studies conducted on *dont* in Frantext (see Section 8.1), we searched two subcorpora of (ATILF et al. 2016): those for 1900–1913 and for 2000–2013. We found 449 occurrences of *de qui* for 2000–2013 and 271 for 1900–1913. These corpus studies were conducted with Anne Abeillé, the results are published in Abeillé & Winckel (2020).

Table 9.1 shows the distribution of *de qui* in different constructions. In the majority of cases, it is used in a relative with an antecedent. It also frequently occurs in interrogatives, and we can find a few examples of free relative clauses and *c'est* clefts.

Table 9.1: Occurrences of *de qui* in Frantext

	Frantext	
	2000–2013	1900–1913
relative clauses with an antecedent	201	172
free relative clauses	0	3
<i>c'est</i> clefts	0	5
direct and indirect questions	129	70
noise	119	21
Total	449	271

## 9 Empirical data on *de qui* relative clauses

The three free relatives are all extractions of the complement of the verb. One example is shown in (9.1).

- (9.1) (Connaissance de l'Est, Paul Claudel, 1907)  
Heureux [[de qui]<sub>i</sub>] une parole nouvelle jaillit avec violence <sub>-i</sub> !  
blessed of who a speech new flows.out with violence  
'Blessed (be the one) from who a new speech flows out violently.'

The other occurrences were noise, i.e. *qui* free relatives like (9.2a), and free choice uses like (9.2b).

- (9.2) a. (Programme sensible, Anne-Marie Garat, 2012)  
le geste craintif de [qui cherche secours]  
the gesture fearful of who seeks help  
'the fearful gesture of who is seeking help'  
b. (Signes de vie, le pacte autobiographique 2, Philippe Lejeune, 2005)  
ne jamais être spécialiste de Proust, ni de [qui que ce soit]  
NEG never be.INF specialist of Proust or of who that it may.be  
'to never be a specialist of Proust, or of whoever it may be'

I will first present the results for the relative clauses, and then for interrogatives and *c'est*-clefts.

### 9.1.3 Results and analysis for relative clauses

It is remarkable that 149 of the 201 relative clauses with *de qui* (73.13% of the total) in Frantext 2000–2013 are from one single author, Anne-Marie Garat. This may be a sign that using *de qui* in relative clauses was stylistically marked, at least during this time period. This provided additional motivation to examine whether our results for *de qui* over the period 2000–2013 were independently confirmed for the period 1900–1913, which obviously did not include the author in question. Since the results are consistent, we think that the overrepresentation of *de qui* by this one author does not disqualify the study.

Table 9.2 summarizes the different functions of *de qui* in the corpus which are also shown in Figure 9.1.<sup>1</sup>

With the exception of adjuncts, all possible functions of a *de*-PP are found in the subcorpus, pied-piping included. *De qui* can be the complement of a verb (9.3), of a noun (9.4), of an adjective (9.5) or of a preposition (9.6).

---

<sup>1</sup>Data missing in the table are relative clauses without a gap, verbless relative clauses and relative clauses with different gap sites, which we excluded.



Table 9.2: Distribution of *de qui* relative clauses in Frantext

Frequency	Frantext	
	2000–2013	1900–1913
Verb	33 (17.01%)	31 (18.45%)
Noun		
Subject	54 (27.84%)	38 (22.62%)
Object	30 (15.46%)	15 (8.93%)
Predicate	8 (4.12%)	4 (2.38%)
Cplt of Preposition	37 (19.07%)	42 (25.00%)
Adjective	2 (1.03%)	1 (0.60%)
Preposition	30 (15.46%)	37 (22.02%)

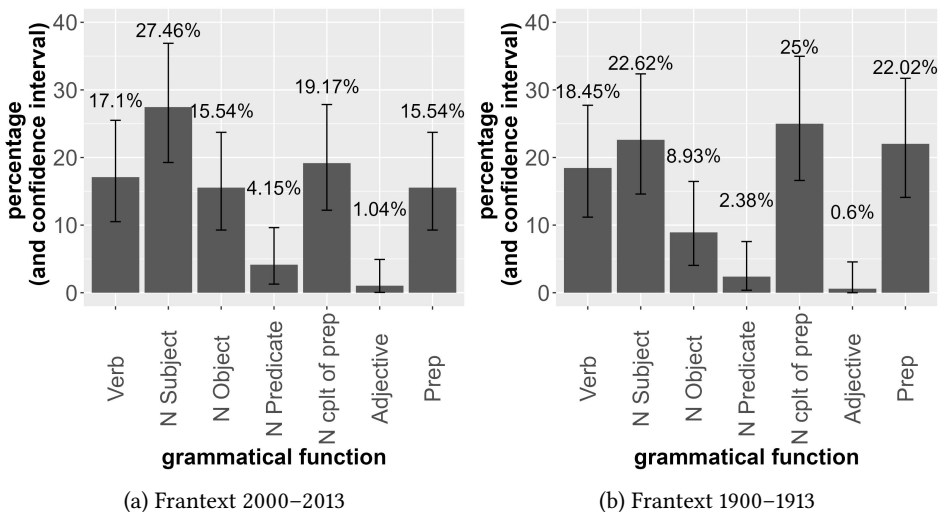
Figure 9.1: Distribution of *de qui* relative clauses in Frantext

9 Empirical data on *de qui* relative clauses

(9.3) Some examples of *de qui* as verb complement

a. (L'Enfant d'Austerlitz, Paul Adam, 1902)

Sa majesté et monsieur, frère du roi, [de qui] [dépend  $-i$   
His majesty and Monsieur brother of.the king of who relies  
surtout l'octroi du privilège], verraient avec  
especially the granting of.the privilege would.see with  
faveur le neveu du postulant près d'entrer au  
preference the nephew of.the applicant near of enter.INF at.the  
séminaire.  
seminary

'His majesty and Monsieur, brother of the king, on whom especially the granting of the privilege relies, would view favourably the applicant's nephew being about to enter the seminary.'

b. (Pense à demain, Anne-Marie Garat, 2010)

Un homme responsable de ses actes est un homme [de qui]<sub>i</sub> [on  
a man responsible of his actions is a man of who one  
peut tout craindre  $-i$ ].  
can everything fear

'A man accountable for his actions is a man from whom anything can be feared.'

(9.4) Some examples of *de qui* as noun complement

a. Subject noun:

(Mes Cahiers : t. 3 : 1902-1904, Maurice Barrès, 1904)

Et en effet, il a l'air, maintenant, d'un vieux pigeon [de  
and in effect he has the air now of an old pigeon of  
qui]<sub>i</sub> [le cœur  $-i$ ] bat.  
who the heart beats

'And indeed he looks now like an old pigeon whose heart is beating.'

b. (Pense à demain, Anne-Marie Garat, 2010)

Elle y a rejoint, un temps, l'exil de sa soeur, [de qui]<sub>i</sub>  
she there has joined a while the exile of her sister of who  
[le vieux mari  $-i$ ] a eu la délicatesse de s'éclipser  
the old husband has had the thoughtfulness of REFL vanish

rapidement.

quickly

‘She joins there her sister’s exile for a while, whose old husband was thoughtful enough to vanish quickly.’

c. Object noun:

(Mes Cahiers : t. 9 : 1911-1912, Maurice Barrès, 1912)

Ne sommes - nous pas [...] le peuple [de qui]<sub>i</sub> saint Bernard a  
NEG are we not the folk of who saint Bernard has  
exprimé [l’ âme -<sub>i</sub>], le pays de la chevalerie.  
expressed the soul the country of the knighthood

‘Aren’t we [...] the people whose soul St. Bernard gave expression to, the land of knighthood?’

d. (Vie et mort de Paul Gény, Philippe Artières, 2013)

De là je fus conduit à la prison de Regina Coeli où je  
from there I was brought at the prison of Regina Coeli where I  
fus interrogé par le juge instructeur [de qui]<sub>i</sub>; je rejetai [la  
was questioned by the judge instructor of who I rejected the  
première déclaration -<sub>i</sub>].  
first statement

‘I was brought from there to the Regina Coeli prison where I was questioned by the investigating judge whose first statement I rejected.’

e. Predicate noun:

(Claudine à l’école, Colette, 1900)

Mais que j’ aime vous entendre et vous voir, vous [...]  
but how I love you.ACC hear.INF and you.ACC see.INF you  
[de qui]<sub>i</sub> je me sens, à chaque instant, [la soeur aînée -<sub>i</sub>] !  
of who I REFL feel at every moment the sister older

‘But how (much) I love to hear and see you, you of whom I feel every second as (if I were) the oldest sister!’

f. (Pense à demain, Anne-Marie Garat, 2010)

C’ est elle qui l’ a posée, non sa bru, [de  
it is her who it.ACC has installed not her daughter-in-law of  
qui]<sub>i</sub> c’ est pourtant [la dernière trouvaille -<sub>i</sub>].  
who it is though the last idea

‘She put it there, not her daughter-in-law, whose latest idea it was, though.’

9 Empirical data on *de qui* relative clauses

g. Noun complement of a preposition:

(La Ville [2e version], Paul Claudel, 1901)

Vous tous, voyez celui [aux pieds de qui]<sub>i</sub> [je me suis  
you all watch this.one at.the feet of who I REFL am  
mise <sub>-i</sub>] !

put

‘You all, watch the man at the feet of whom I placed myself.’

h. (D’autres vies que la mienne, Emmanuel Carrère, 2009)

Dans dix ans, Amélie serait une jeune fille [[dans la vie  
in ten years Amélie would.be a young woman in the life  
de qui]<sub>i</sub> j’aurais peut-être un rôle <sub>-i</sub>] [...].

of who I would.have maybe a role

‘Ten years from now, Amélie may be a young woman in the life of  
whom I would maybe play a role.’

(9.5) Some examples of *de qui* as adjective complement

a. (Mes Cahiers : t. 2 : 1898-1902, Maurice Barrès, 1902)

[...] je vois chez lui la haine de l’ étranger, du “monsieur”

I see by him the hatred of the stranger of.the sir

[de qui]<sub>i</sub> son père semblait [inférieur <sub>-i</sub>].

of who his father seemed inferior

‘In him, I see the hatred against the stranger, against this “sir” to  
whom his father seemed inferior.’

b. (Programme sensible, Anne-Marie Garat, 2012)

À quoi sert - il de [...] classer la dynastie des criminels [de  
at what helps it of class.INF the dynasty of.the criminals of  
qui]<sub>i</sub> nous sommes [issus <sub>-</sub>].

who we are originating

‘What does it help to classify the dynasty of criminals from whom  
we originate.’

(9.6) Some examples of *de qui* as complement of a preposition

a. (Histoire de l’art : L’Art médiéval, Elie Faure, 1912)

Il fut la petite église des campagnes [autour de qui]<sub>i</sub> [s’  
it was the small church of.the country around of who REFL  
assemblaient <sub>-i</sub> quelques chaumes] [...].

gathered some thatched.cottages

‘It was the small country church around which some thatched  
cottages gathered.’

- b. (À défaut de génie, François Nourissier, 2000)  
 [...] que venait - il faire parmi les étudiants anémiés [[autour  
 what came he do.INF among the students anemic around  
 de qui]<sub>i</sub> rôdaient -<sub>i</sub> les idées noires et les BK] ?  
 of who lurked the thoughts black and the tuberculosis  
 ‘What was he looking for among the anemic students around  
 whom black thoughts and tuberculosis were lurking?’

We observe a large number of extractions from the NP (subject, object or predicate), many of them extractions from the subject. Pied-piping is frequent as well. However, it is important to note that in Frantext 2000–2013, the majority of these extractions from NPs, including all instances of extractions from the subject (the most common usage), originate from Anne-Marie Garat. Extraction out of the subject is only the second most common usage for 1900–1913, it is nevertheless quite widespread. Thus, we can be confident that the corpus findings contradict Tellier’s (1990)’s claim that extraction out of the subject is impossible with *de qui*.

### 9.1.3.1 Subject position

As in the case of *dont*, extraction out of a postverbal subject is very rare, but attested. We find three occurrences, all in the subcorpus 1900–1913, and all involving body parts. One example can be seen in (9.7).

- (9.7) (L’enfant d’Austerlitz, Paul Adam, 1902)  
 le père Anselme, [de qui]<sub>i</sub> voltigeaient [les boucles angéliques -<sub>i</sub>]  
 the father Anselme of who fluttered the curls angelic  
 sur un col gras  
 on a collar oily  
 ‘Father Anselme, whose angelic curly hair fluttered down on an oily collar’

Among all extractions out of the subject, there are no long distance dependencies. In three cases, there is a parenthetical adjunct between *de qui* and the subject. One example is reproduced in (9.8).

- (9.8) (Pense à demain, Anne-Marie Garat, 2010)  
 Eliot Kidman [de qui]<sub>i</sub>, se prévalait - il, [la mère -<sub>i</sub>] était une  
 Eliot Kidman of who REFL prided he the mother was an  
 authentique Cheyenne  
 authentic Cheyenne  
 ‘Eliot Kidman whose mother, so he prided himself, was an authentic Cheyenne’

9.1.3.2 Verb types

Table 9.3 shows the verb types involved in extraction out of the subject. Just as in *dont* relative clauses, all kind of verbs are attested. Transitives (9.9a), unergatives (9.9b) and state verbs (9.9c) are frequent. There are only a few occurrences of passives (9.9d), unaccusatives (9.9e) and mediopassives (9.9f).

Table 9.3: Verb types in *dont* relative clauses with extraction out of the subject

Verb type	Frantext	
	2000–2013	1900–1913
Passive	3 (5.56%)	2 (5.26%)
Unaccusative	2 (3.70%)	2 (5.26%)
Mediopassive	4 (7.41%)	3 (7.89%)
Transitive	23 (42.59%)	14 (36.84%)
Unergative	11 (20.37%)	10 (26.32%)
State	11 (20.37%)	7 (18.42%)

- (9.9) a. (Pense à demain, Anne-Marie Garat, 2010)  
 lui [de qui]<sub>i</sub> [la trogne <sub>-i</sub>] inspire la caricature  
 him of who the face inspires the caricature  
 ‘him, whose face inspires caricature’ (i.e. makes people want to caricature it)
- b. (La Leçon d’amour dans un parc, René Boylesve, 1902)  
 [des] femmes de cet âge, [de qui]<sub>i</sub> [les charmes <sub>-i</sub>] [...] ont  
 DET women of this age of who the charms have  
 grandi d’ année en année  
 grown of year in year  
 ‘women as old, whose charms have grown with the years’
- c. (Le Journal d’une femme de chambre, 1900)  
 toi [de qui] [l’ âme <sub>-i</sub>] est si merveilleusement jumelle de la  
 you of who the soul is so wonderfully twin of the  
 mienne  
 mine  
 ‘you whose soul is such a wonderful twin of mine’

- d. (Pense à demain, Anne-Marie Garat, 2010)  
 ces gens [de qui]<sub>i</sub> [le nom -<sub>i</sub>] n' a plus été  
 these people of who the name NEG has not.more been  
 prononcé  
 spoken  
 'these people whose name was not spoken anymore'
- e. (De Goupil à Margot : histoire de bêtes, Louis Pergaud, 1910)  
 [des] serpents géants [...] [de qui]<sub>i</sub> [la tête -<sub>i</sub>] et [la queue -<sub>i</sub>]  
 DET snakes giant of who the head and the tail  
 seraient restées enfouies  
 would.be stayed buried  
 'giant snakes whose head and tail would still be buried'
- f. (La Vie unanime, Jules Romains, 1908)  
 nous [de qui] [le vouloir -<sub>i</sub>] s' étale dru comme la  
 us of who the will REFL spread thick like the  
 crinière des bêtes  
 mane of.the beasts  
 'we whose will is thick like a beast's mane'

We can compare the verb types attested in extraction out of the subject with those in other kinds of extractions. Figure 9.2 illustrates this for Frantext 1900–1913, but the results are similar for Frantext 2000–2013. There is no significant difference between the two groups, both of which include many transitives and unergatives. Notice that in both groups the frequency of passives and mediopassives is not significantly above zero. Moreover, the frequency of unaccusatives in the relatives with extraction out of the subject is not significantly above zero. This goes against the idea that extraction out of the subject is restricted to passives and unaccusatives: in fact, these verb types are very rare. While I cannot explain this difference compared to *dont* relative clauses (see Figure 8.4), it seems that the decisive factor is the relative word, not extractions out of the subject.

Figure 9.3 shows the distribution of transitive verbs and other verb types, and we can see that, although transitive verbs are numerically less frequent in extraction out of the subject than in the other kinds of *de qui* relative clauses, the difference is not significant.<sup>2</sup> This contrasts with *dont* relative clauses, where non-transitive verbs were more frequent than transitive verbs in this type of extraction.

<sup>2</sup>Pearson's chi-squared Tests performed on each subcorpus confirm that the differences are not significant. Pearson's chi-squared Tests are performed using the function `chisq.test()` from the R Stats Package (R Core Team 2018).

9 Empirical data on *de qui* relative clauses

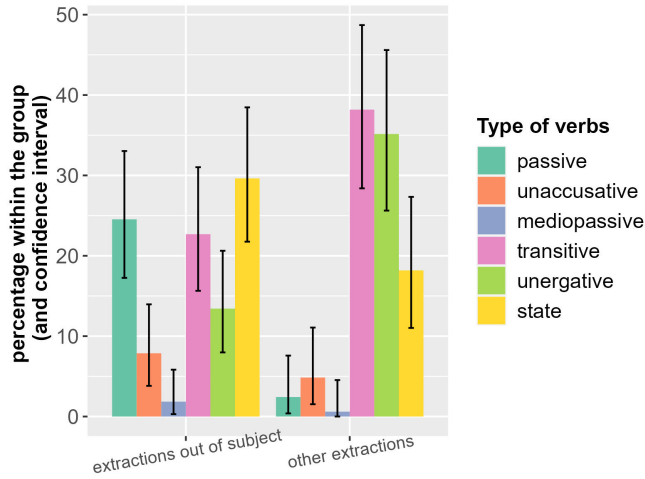

Figure 9.2: Frantext 1900–1913: Distribution of the verb types in extraction out of the subject, compared to other extraction types in *de qui* relative clauses. See page 129 for the confidence intervals (here six comparisons). The percentage is given for each group (extraction out of the subject vs. other extraction types).

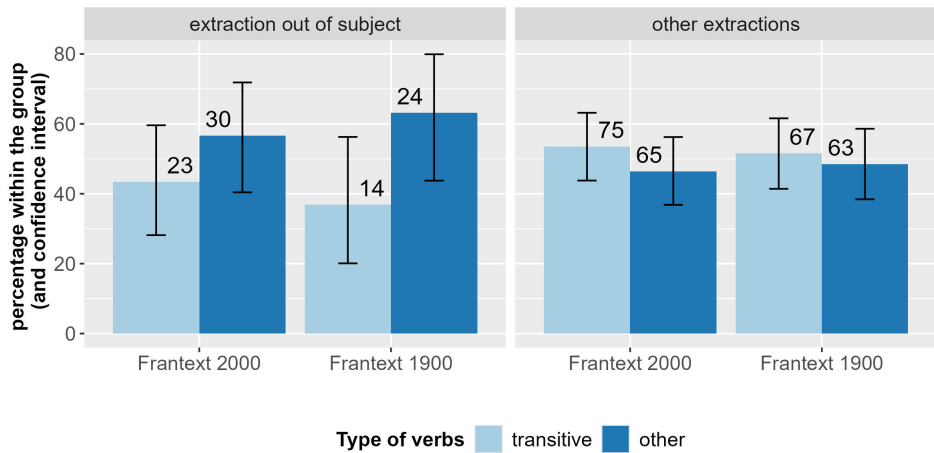

Figure 9.3: Distribution of the transitive verbs in *de qui* relative clauses. See page 129 for the confidence intervals (here two comparisons). The percentage is given for each group (a group = one kind of extraction in one corpus).



### 9.1.3.3 Other factors

Number and definiteness of the antecedent do not seem to follow any specific pattern. Appendix C provides the interested reader with more details.

Extraction out of the subject is restrictive in most cases, in contrast with *dont* relative clauses, and contrary to our expectations.

Regarding the most common semantic relations holding between the relative phrase and its head noun, we can see that *de qui* and *dont* relative clauses in Frantext 1900–1913 are remarkably similar. By contrast, the distribution varies in Frantext 2000–2013 for extractions out of the subject: there are more part-whole relations in *dont* relative clauses, more quality (e.g. beauty) or relational (e.g. mother) relations in *de qui* relative clauses. Given the wide variety of possible semantic relationships, more data would be needed to draw any clear conclusions, but it seems that the use of *dont* and *de qui* has become specialized in the 21st century.

In Abeillé & Winckel (2020) we attempted to predict the usage of *dont* or *de qui* by applying comprehensive statistical models to our data. These models were very exploratory and did not clearly identify one or more decisive factors. I invite the reader to consult this article to learn more.

### 9.1.4 Results for interrogatives

After excluding verbless and gapless interrogatives, we found 75 interrogatives in Frantext 2000–2013 (33 direct, 42 indirect)<sup>3</sup>, and 51 interrogatives in Frantext 1900–1913 (32 direct, 19 indirect), see Table 9.4.

Table 9.5 and Figure 9.4 on page 207 summarize the different functions of *de qui* in the corpus. *De qui* can be the complement of a verb (9.10), of a noun (9.11), of an adjective (9.12) or of a preposition (9.13).

(9.10) Some examples of *de qui* as verb complement

a. (Les Bienveillantes, Jonathan Littell, 2006)

[De qui]<sub>i</sub> devons - nous recevoir nos ordres <sub>-i</sub>, à la fin ?  
 of who must we receive.INF our orders at the end  
 ‘From whom should we really get our orders?’

---

<sup>3</sup>26 direct questions (78.79%) and 13 indirect questions (30.95%) were again from Anne-Marie Garat. She is therefore also relatively overrepresented in the interrogatives, albeit less so than in the relative clauses.

9 Empirical data on *de qui* relative clauses

Table 9.4: *De qui* interrogatives in Frantext

	Frantext	
	2000–2013	1900–1913
direct questions	78	47
- with a verb and a gap	33	32
- verbless	25	13
- <i>de qui</i> in situ	20	2
indirect questions	51	23
- with a verb and a gap	42	19
- verbless	5	4
- <i>de qui</i> in situ	4	0
Total	129	70

Table 9.5: Distribution of *de qui* interrogatives in Frantext

Frequency	Frantext	
	2000–2013	1900–1913
Verb	49 (65.33%)	38 (74.51%)
Noun		
Object	2 (2.67%)	0
Indirect object	3 (4.00%)	0
Predicate	11 (14.67%)	6 (11.76%)
Cplt of Preposition	7 (9.33%)	6 (11.76%)
Adjective	1 (1.33%)	1 (1.96%)
Preposition	2 (2.67%)	0

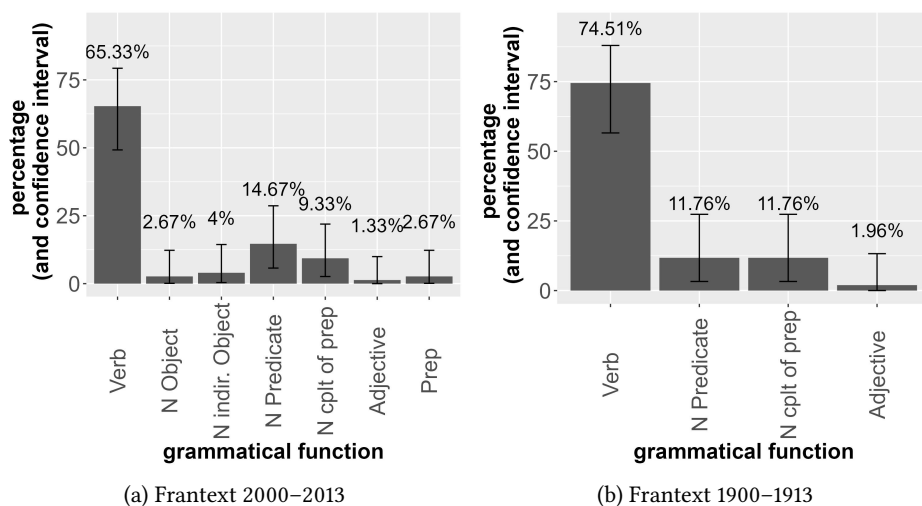
Figure 9.4: Distribution of *de qui* interrogatives in Frantext

- b. (Jean-Christophe : Dans la maison, Romain Rolland, 1909)  
 Et lorsqu' il lui demanda [de qui]<sub>i</sub>; [elle tenait ces  
 and when he her.DAT asked of who she hold these  
 détails -<sub>i</sub>], elle lui dit que c' était de Lucien  
 details she him.DAT said that it was of Lucien  
 Lévy-coeur [...].  
 Lévy-coeur  
 'And when he asked her from whom she got these details, he said  
 that it was from Lucien Lévy-coeur.'

(9.11) Some examples of *de qui* as noun complement

- a. Object noun:  
 (La vie possible de Christian Boltanski, Christian Boltanski &  
 Catherine Grenier, 2007)  
 [...] [de qui]<sub>i</sub> as - tu utilisé [les voix -<sub>i</sub>] ?  
 of who have you used the voices  
 'Whose voices did you use?'
- b. Indirect object:  
 (La voix des mauvais jours et des chagrins rentrés, Jean-Luc  
 Benoziglio, 2004)  
 [...] il a vu [de qui]<sub>i</sub> [...] cette morne et interminable liste  
 he has seen of who this bleak and endless list

9 Empirical data on *de qui* relative clauses

avait le chagrin de faire part de [la soudaine et  
had the grief of do.INF announcement of the sudden and  
tragique disparition <sub>-i</sub>] [...].

tragic loss

'He saw whose sudden and tragic loss this endless, bleak list was very sorry to announce.'

c. Predicate noun:

(Mon évacion, Benoîte Groult, 2008)

[De qui]<sub>i</sub> est - ce [la faute <sub>-i</sub>] ?

of who is it the mistake

'Whose mistake is it?'

d. (Jean-Christophe : L'Adolescent, Romain Rolland, 1905)

[De qui] était - il [la proie <sub>-i</sub>] ?

of who was he the prey

'Whose prey was he?'

e. Noun complement of a preposition:

(Dans la main du diable, Anne-Marie Garat, 2006)

[...] [au service de qui]<sub>i</sub> se mettait - il <sub>-i</sub> ?

at.the service of who REFL put he

'At whose disposal did he put himself?'

f. (Aimé Pache, peintre vaudois, Charles-Ferdinand Ramuz, 1911)

[De la part de qui]<sub>i</sub> venez - vous <sub>-i</sub> ?

of the behalf of who come you

'On behalf of whom are you coming?'

(9.12) Some examples of *de qui* as adjective complement

a. (L'événement, Annie Ernaux, 2000)

Il voulait savoir [de qui]<sub>i</sub> j' étais [enceinte <sub>-i</sub>], depuis quand.

he wanted know.INF of who I was pregnant since when

'He wanted to know by whom I was pregnant, since when.'

b. (Le Journal d'une femme de chambre, Octave Mirbeau, 1900)

Et [de qui]<sub>i</sub> pourriez - vous être [enceinte <sub>-i</sub>], Marianne ?

and of who could you be.INF pregnant Marianne

'And of whom could you be pregnant, Marianne?'

- (9.13) An example of *de qui* as preposition complement  
 (Un roman russe, Emmanuel Carrère, 2007)  
 Sergueï Sergueïevitch, [à côté de qui]<sub>i</sub> es - tu assis -<sub>i</sub> ?  
 Sergueï Sergueïevitch at next of who are you sitting  
 ‘Sergueï Sergueïevitch, next to whom are you sitting?’

Of course, the absence of any extraction out of the subject among interrogatives is striking, especially because it is the most common use in relative clauses. Such a difference between relative clauses and interrogatives is not expected under Tellier’s (1990) proposal. In general, there is very little extraction out of an NP: 16 occurrences (21.33% of all interrogatives) in Frantext 2000–2013 and 6 occurrences (11.76%) in Frantext 1900–1913.

Notice that in Frantext 2000–2013, extraction out of a direct object, out of an indirect object, out of an adjective, and *de qui* as the complement of a preposition are all statistically not higher than zero. In Frantext 1900–1913, extraction out of an adjective is not statistically higher than zero; moreover, there are no examples of extraction out of a direct or indirect object, and no case in which *de qui* is the complement of a preposition.

The by far most common usage for *de qui* in interrogatives is with verb complements. The presence of extractions out of the indirect object is surprising, but all three occurrences are from the same sentence (and no other occurrence can be found in the other corpus studies we conducted). Hence, we can consider this an exceptional case, even though it is an indicator that extractions out of a PP are not utterly ruled out by syntax.

### 9.1.5 Results for *c’est-clefts*

*C’est-clefts* are only found in Frantext 1900–1913. Of the five hits, three are pied-piping cases like (9.14a) where *de qui* is the complement of a noun complement of a preposition, and two are extractions out of an object NP like (9.14b). Two of the pied-piping cases are presentationals.

- (9.14) a. (A.O. Barnabooth, ses oeuvres complètes : le Pauvre chemisier ;  
 Poésies ; Journal intime, Valery Larbaud, 1913)  
 C’ était lui, l’ ennemi [sur la tête de qui]<sub>i</sub> [je devais mettre  
 it was him the enemy on the head of who I must put.INF  
 les charbons ardents -<sub>i</sub>] !  
 the coal lighted  
 ‘It was him, the enemy on whose head I had to pour the lighted  
 coal!’

- b. (La Leçon d'amour dans un parc, René Boylesve, 1902)  
Alors il inclinait l' entretien sur Châteaubedeau, et c'  
then he led the conversation on Châteaubedeau and it  
était celui - là [de qui]<sub>i</sub>, dans l' ombre, il étranglait [le  
was this there of who in the shadow he choked the  
fantôme -<sub>i</sub>].  
ghost  
'He then led the conversation on Châteaubedeau, and it was this  
one that he secretly choked the ghost of' (intended: he secretly  
choked the ghost of Châteaubedeau)

### 9.1.6 General conclusion on the corpus studies on *de qui*

Both corpus studies on *de qui* show that extraction out of the subject is frequent in relative clauses. It is not a recent development: in both time periods, extracting out of the subject is more frequent than extracting out of the object (even though this difference is not statistically significant). In this respect, *de qui* as a relative word does not differ from *dont* in our data.

Extraction out of a subject NP is not restricted to a certain verb type. Transitive verbs are found frequently in the construction; however, chi-square tests and regression analyses show that they are significantly less frequent in extraction out of a subject NP than in other usages of *dont* and *de qui*. There are also more passives in extraction out of the subject than in the other kinds of extraction. This difference in frequency may explain the intuition reported in the literature that extraction out of the subject is less natural with transitive verbs and more natural with passives. However, it does not explain why extraction out of the subject of a transitive verb is marked as ungrammatical by some scholars.

Both relative words occur in long-distance dependencies, even though they seem to be very rare in Frantext. In general, *dont* is used far more often than *de qui*, but this seems to be one of the few differences between the two relative words. Extraction out of the subject also tends to involve part-whole relations (especially for body parts) more often than extraction out of the object. More importantly, the occurrences of *de qui* are due to just a few authors in Frantext, whereas *dont* seems to be more common. Using *de qui* may thus have a stylistic flavor, and this could be one reason for the diverging intuitions about its use.

We observed a big difference in the usage of *de qui* in relative clauses vs. interrogatives. In the latter, *de qui* is used almost exclusively for extraction of the complement of the verb. Extraction out of NPs is rare (whereas it is very frequent in relative clauses), and we did not find any extraction out of a subject NP. This

may be related to the fact that subjects tend to be topics, and that focusing a part of a topic would create a discourse clash, making it dispreferred and unlikely to occur in well-edited production data like the texts we can find in Frantext.

## 9.2 Experiment 5: Acceptability judgment study on *de qui* relative clauses with an animate antecedent and animacy mismatch between subject and object

The corpus results presented in Section 9.1 suggest that relative clauses with *dont* and *de qui* are similar with respect to extraction out of the subject. However, there is a long tradition of assuming that extractions out of the subject with *dont* are exceptional because *dont* is not a pronoun, or because it has genitive case. This was first proposed by Tellier (1990, 1991), and then echoed by Stepanov (2007) and Heck (2009), even though it had already been criticized by Godard (1988) (see the whole discussion in Section 2.3.1). On these grounds we considered useful to test *de qui* relative clauses with a methodology similar to the one adopted in the previous experiments for *dont* relative clauses.

### 9.2.1 Design and materials

The experiment was an acceptability judgment task with a 2\*2 design. The design was very similar to the one in Experiment 4, but there were no ungrammatical controls. We compared extractions out of subjects (9.15a) with extractions out of objects (9.15b), and paired each with a non-extraction control including coordination (9.16a) and (9.16b).

- (9.15) a. Condition subject + PP-extracted:  
 J' ai exclu un garçon [de qui]<sub>i</sub> [l' arrogance -<sub>i</sub>] rebute  
 I have excluded a boy of who the arrogance repels  
 mes collègues.  
 my colleagues  
 'I excluded a boy whose arrogance repels my colleagues.'
- b. Condition object + PP-extracted:  
 J' ai exclu un garçon de qui mes collègues détestent l'  
 I have excluded a boy of who my colleagues hate the  
 arrogance.  
 arrogance  
 'I excluded a boy of who my colleagues hate the arrogance.'

## 9 Empirical data on *de qui* relative clauses

- (9.16) a. Condition subject + noextr:  
J' ai exclu un garçon et son arrogance rebute mes  
I have excluded a boy and his arrogance repels my  
collègues.  
colleagues  
'I excluded a boy and his arrogance repels my colleagues.'
- b. Condition object + noextr:  
J' ai exclu un garçon et mes collègues détestent son  
I have excluded a boy and my colleagues hate his  
arrogance.  
arrogance  
'I excluded a boy and my colleagues hate his arrogance.'

It was not possible to use the same stimuli as in Experiment 4 because they contained inanimate antecedents and *de qui* requires animate antecedents. But as in Experiment 4, the relation between *de qui* and the gap expressed a quality (e.g. *arrogance* 'arrogance', *violence* 'violence') and we used psych verbs that come in pairs (e.g. *rebuter* 'repel' and *détester* 'hate').

We tested 20 items, each appearing in the four conditions already described. In addition, the experiment included 42 distractors. Each item and distractor was followed by a comprehension question. The item presented here as an example was paired with the comprehension question *Qui est arrogant ?* ('Who is arrogant?').

### 9.2.2 Predictions

The predictions for this experiment (as well as for all other experiments on relative clauses that follow) are similar to the predictions already discussed in Experiment 4. They are summarized in Table 9.6.

### 9.2.3 Procedure

We conducted the Experiment on the Ixet platform (Drummond 2010). The procedure for acceptability judgment tasks is described in Section 8.2.3. Participants rated the sentences on a Likert scale from 1 to 10, 1 being labeled as "bad" and 10 being labeled as "good". After each sentence, participants had to answer a comprehension question, for example *Qui est arrogant ?* ('Who is arrogant?') which appeared on the screen together with two possible answers. Participants had to click on the appropriate answer in order to proceed to the following sentence.



Table 9.6: Predictions of the different accounts for Experiments 5, 6, 7 and 8 (relative clauses). *Notes:* (a) Condition subject + PP-extracted (b) Condition object + PP-extracted (c) Condition subject + no extraction (d) Condition object + no extraction (e) Condition subject + ungrammatical (f) Condition object + ungrammatical.

		Predictions				
		“subject island” accounts	no-island accounts			
		“traditional” syntactic account	processing account with surprisal due to subject complexity	BCI account (Goldberg 2006)	account based on linear distance (DG, DLT)	FBC constraint account
extractions out of the subject vs. extractions out of the object	(a) < (b)	(a) < (b)	(a) < (b)	(a) < (b)	(a) > (b)	(a) ≥ (b)
extractions vs. non-extractions	main effect of extraction + interaction effect such that (a) < (b,c,d)	main effect of extraction + interaction effect such that (a) < (b,c,d)	main effect of extraction + interaction effect such that (a) < (b,c,d)	main effect of extraction + interaction effect such that (a) < (b,c,d)	interaction effect such that (b) < (a,c,d)	main effect of extraction + no interaction
extractions out of the subject vs. ungrammatical control	(a) ≈ (e)	(a) > (e)	(a) > (e)	(a) > (e)	(a) > (e)	(a) > (e)
extractions vs. ungrammatical controls	interaction effect such that (b) > (a,e,f)	main effect of grammaticality	main effect of grammaticality	main effect of grammaticality	main effect of grammaticality	main effect of grammaticality

The experiment took approximately 20 minutes to complete. We recruited the participants on the R.I.S.C. website (<http://experiences.risc.cnrs.fr/>) and on social media (e.g. Facebook).

#### 9.2.4 Participants

The study was run between April and October 2017. 75 participants took part in the experiment. Data from 60 participants were included in the analysis based on our inclusion criteria.<sup>4</sup> The 60 participants were aged 19 to 79 years. 41 of them self-identified as women, and 19 as men. Four participants (6.67%) indicated having an educational background related to language.

#### 9.2.5 Results and analysis

Figure 9.5 summarizes the results of the acceptability judgment task.<sup>5</sup> In the subextraction condition, extraction out of the subject (9.15a) received a mean acceptability rating of 5.02, slightly lower than extraction out of the object (9.15b) with a mean rating of 5.36. The control conditions without extraction were rated better overall: 7.80 in the subject condition (9.16a) and 7.62 in the object condition (9.16b).

Figure 9.5 suggests potential ceiling effects in the non-extraction conditions. Unlike the extractions out of NPs with *dont*, extractions out of NPs with *de qui* do not display ceiling effects. This is corroborated by Figure 9.6: there is a clear ceiling effect for non-extraction conditions, but not for extraction conditions. However, the distribution of the subject + extraction condition is not fully normal, it is flat.

Another representation of the results is given by the ROC and zROC curves of the results in Figure 9.7. There is strong discrimination between the non-extraction conditions (grey baseline) and the extraction condition (blue lines). The zROC curve for the object condition is a straight line parallel to the baseline, but the zROC for the subject condition is not. This corroborates the impression given by Figure 9.6: the distribution of the results in the subject condition is not fully normal.

---

<sup>4</sup>In addition to the usual criteria, we excluded three participants who did not use the whole Likert scale. To calculate accuracy, we excluded not only the answers to comprehension questions of the practice items, but also one series of distractors that had an overall accuracy rate of 71% only.

<sup>5</sup>We involuntarily introduced a typo in one condition of one experimental item, which was therefore excluded from the results and treated as a distractor. The results presented here are therefore based on 19 experimental items.

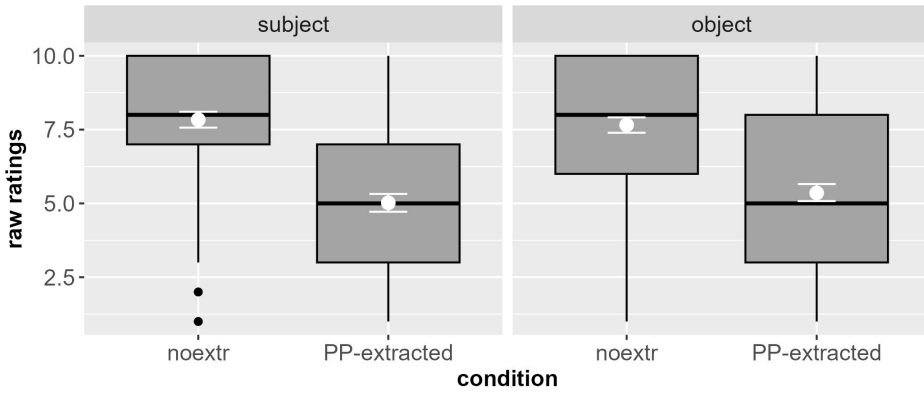

Figure 9.5: Acceptability judgments by condition in Experiment 5. The grey box plots indicate the median and quartiles of the results. Black points are outliers. Mean and confidence intervals are indicated in white.

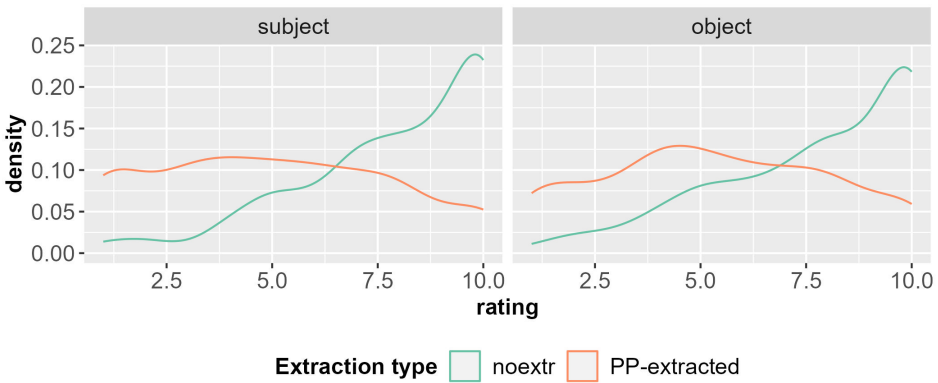

Figure 9.6: Density of the ratings across conditions for Experiment 5

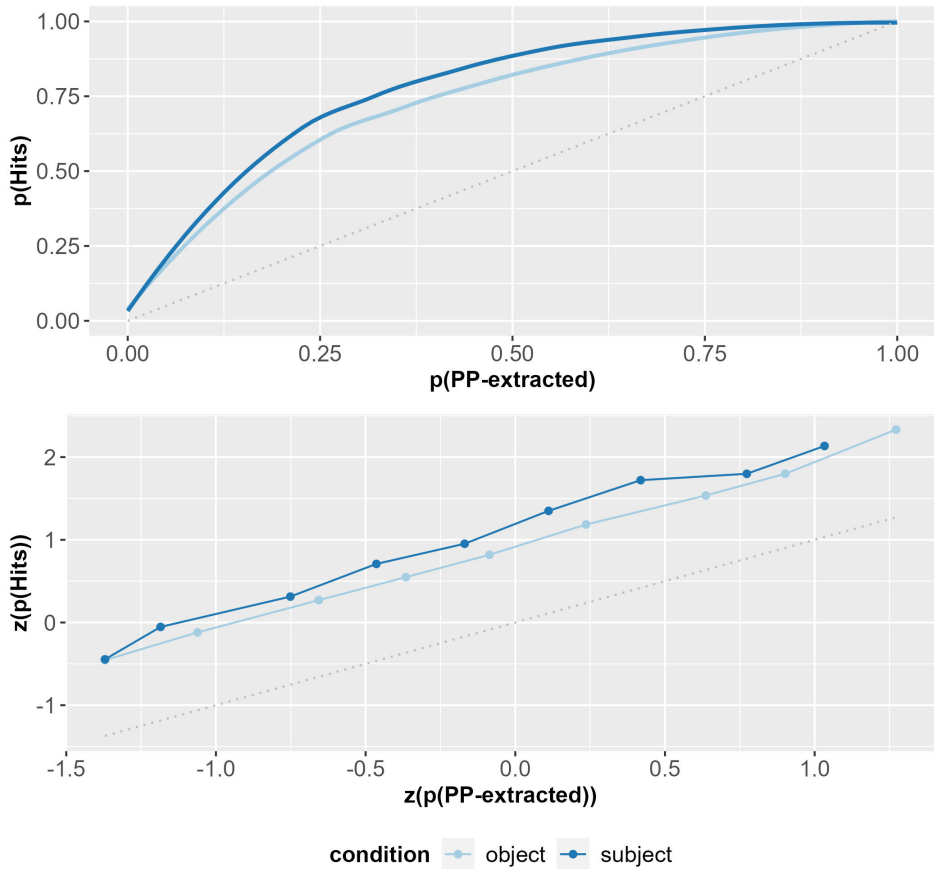

Figure 9.7: ROC curves (top) and zROC curves (bottom) of the non-extraction conditions compared to their respective subextraction conditions, represented by the dotted grey baseline (Dillon & Wagers 2019’s method) in Experiment 5.

Indeed, if we look at the results for the early trials on Figure 9.8 (page 217), we see that the distribution looks more normal. I think that the non-normal distribution of the subextraction ratings is due to the high degree of habituation to subextractions (see below).

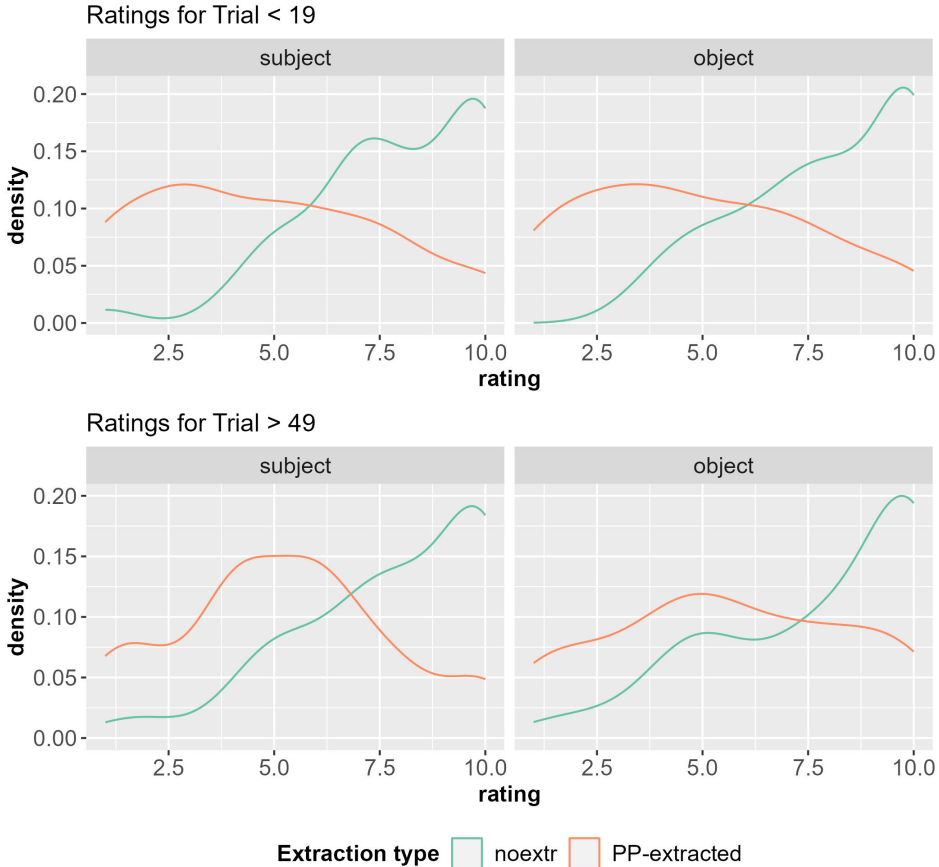

Figure 9.8: Density of the ratings across conditions for the beginning (first quartile, top) and the end (fourth quartile, bottom) of Experiment 5

The ROC and zROC curves in Figure 9.9 depict the discrimination between the subject and object conditions. The ROC curves show that the participants barely discriminate between the subject and object conditions. The zROC curves are relatively straight.

9 Empirical data on de qui relative clauses

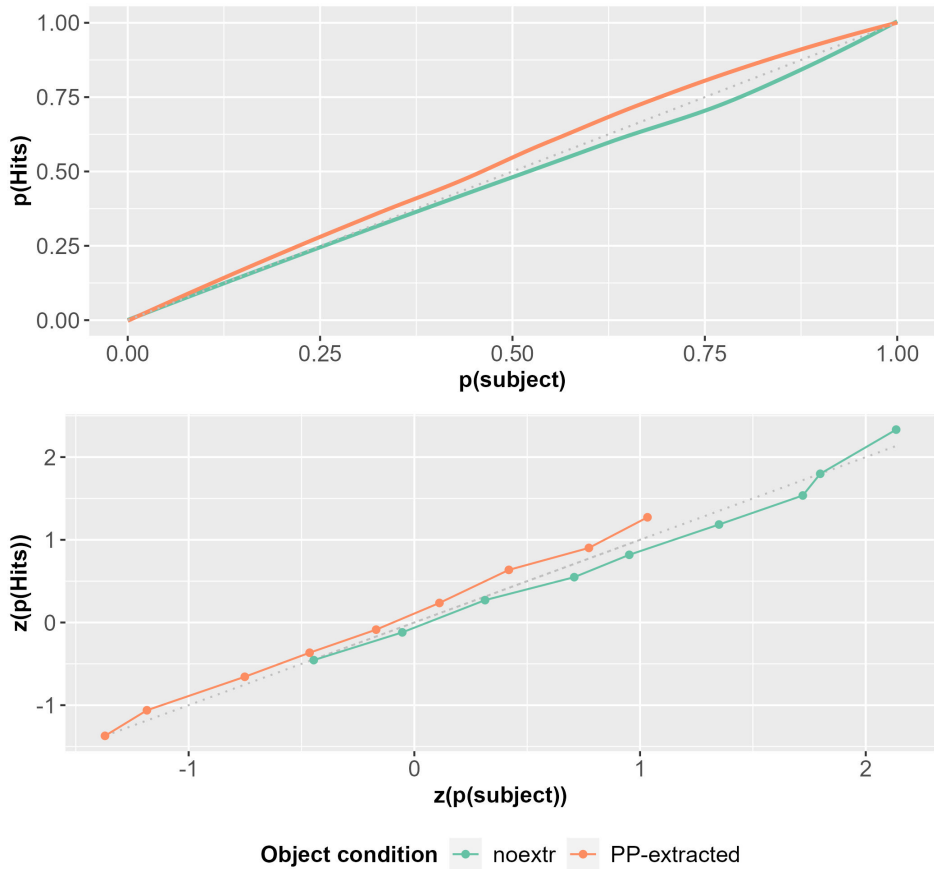

Figure 9.9: ROC curves (top) and zROC curves (bottom) of the object conditions compared to their respective subject conditions, represented by the dotted grey baseline (Dillon & Wagers 2019's method) in Experiment 5.

### 9.2.5.1 Habituation

Figure 9.10 shows the habituation effects in the course of the experiment. The non-extraction condition does not display any habituation effects, there is even a slight decrease of acceptability for the subject + non-extraction condition. However, we can see strong habituation effects in the extraction conditions.

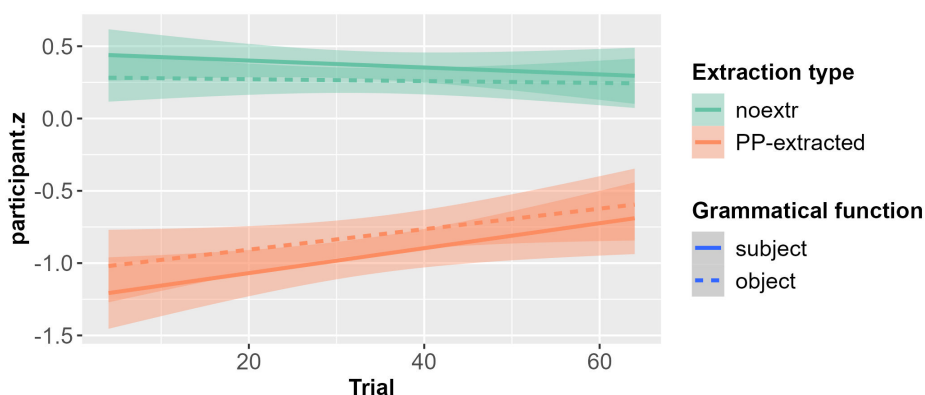

Figure 9.10: Changes in the average acceptability ratings (z-scored by participant) for each condition of Experiment 5 in the course of the experiment

### 9.2.5.2 Comparing subextraction from the subject with subextraction from the object

We fitted a first model to compare the extractions out of the subject and out of the object on their own (mean centered with subject coded negative and object coded positive). We included trial number as a covariate, and random slopes for the fixed effect grouped by participants and items. The results of the model are reported in Table 9.7. There is a significant effect of syntactic function: the object condition received significantly higher ratings than the subject condition. There is also a significant effect of trial (habituation).

In a second model, we compared the subextractions with the non-extractions. We fitted a model crossing syntactic function and extraction type (mean centered with extraction coded positive, non-extraction coded negative). We included trial number as a covariate, and random slopes for all fixed effects and covariates grouped by participants and items. The results of the model are reported in Table 9.8. There is a significant main effect of extraction type in favor of the non-extraction controls. There is no significant main effect of syntactic function, no

9 Empirical data on *de qui* relative clauses

Table 9.7: Results of the Cumulative Link Mixed Model (model n°1)

	Estimate	SE	z	Pr(>  z )	Odd.ratio
function	0.201	0.088	2	<0.05	1.22
trial	0.011	0.004	2	<0.05	1.01

significant main effect of trial (habituation) and no significant interaction effect. Figure 9.11 shows the interaction: we see a weak tendency toward an interaction effect. Furthermore, if we compare the AUC (see Figure 9.9 on page 218), the difference is not significant, either.

Table 9.8: Results of the Cumulative Link Mixed Model (model n°2)

	Estimate	SE	z	Pr(>  z )	Odd.ratio
function	0.078	0.068	1	0.2489	1.08
extraction type	-1.635	0.234	-7	<0.001	5.13
trial	0.004	0.003	1	0.2093	1.00
function:extraction type	0.110	0.078	1	0.1604	1.12

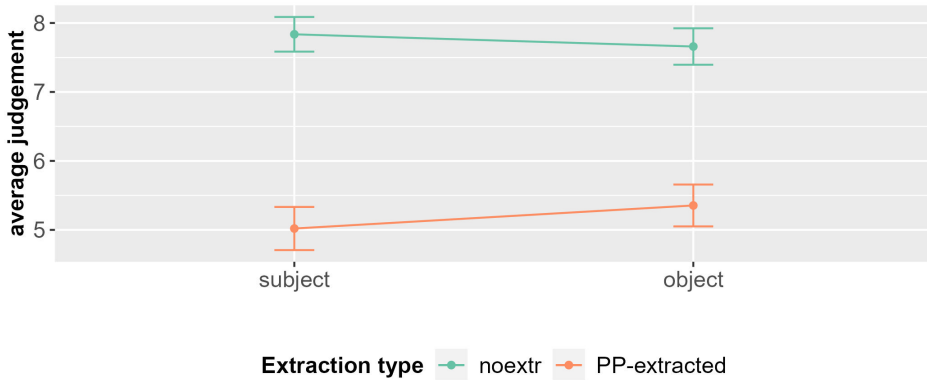

Figure 9.11: Interaction between syntactic function and extraction type in Experiment 5



### 9.2.6 Discussion

The results of Experiment 5 are puzzling. On the one hand they seem more compatible with accounts that expect a superadditivity effect, because there is a significant difference between extractions out of the subject vs. the object: extractions out of the object were rated better than extractions out of the subject (model n°1). On the other hand, there is no significant interaction effect. This latter fact can be due to a weakness of the experiment: perhaps the number of participants was not sufficient to allow a small effect to become apparent. In that case, the effect size of the interaction must be rather small. A small-sized effect is not expected by a traditional syntactic account, but can be compatible with processing accounts based on subject complexity.

The results are in contradiction with predictions of a processing account based on memory costs, because the extraction out of the subject should be better than the extraction out of the object. The results are also unexpected under the FBC constraint.

The next experiment tested the same stimuli with *dont* instead of *de qui*, in order to see if we reproduce the same results.

## 9.3 Experiment 6: Acceptability judgment study on *dont* relative clauses with an animate antecedent and an animacy mismatch between subject and object

In this study, we tested the same stimuli as in Experiment 5, but replaced the relative word *de qui* by *dont*. We did this in reaction to the results of that study, where we saw extractions out of the subject having lower ratings than extractions out of the object, contrary to our previous experiments on *dont* (Experiments 1 to 4). In the previous experiments, we always tested *dont* relative clauses with an inanimate antecedent. This study aims to be parallel to Experiment 5.

### 9.3.1 Design and materials

This experiment reproduces the design of the previous one: it is an acceptability judgment task with a 2\*2 design, as shown below:

## 9 Empirical data on *de qui* relative clauses

- (9.17) a. Condition subject + PP-extracted:  
J' ai exclu un garçon dont<sub>i</sub> [l' arrogance <sub>-i</sub>] rebute  
I have excluded a boy of.which the arrogance repels  
mes collègues.  
my colleagues  
'I excluded a boy whose arrogance repels my colleagues.'
- b. Condition object + PP-extracted:  
J' ai exclu un garçon dont mes collègues détestent  
I have excluded a boy of.which my colleagues hate  
l' arrogance.  
the arrogance  
'I excluded a boy of which my colleagues hate the arrogance.'
- (9.18) a. Condition subject + noextr:  
J' ai exclu un garçon et son arrogance rebute mes  
I have excluded a boy and his arrogance repels my  
collègues.  
colleagues  
'I excluded a boy and his arrogance repels my colleagues.'
- b. Condition object + noextr:  
J' ai exclu un garçon et mes collègues détestent son  
I have excluded a boy and my colleagues hate his  
arrogance.  
arrogance  
'I excluded a boy and my colleagues hate his arrogance.'

We tested the same 20 items and 42 distractors as in Experiment 5. Each item and distractor was also followed by the same comprehension question as in Experiment 5 (e.g. for the example item: *Qui est arrogant ?*, 'Who is arrogant?').

### 9.3.2 Predictions

The predictions for this experiment are similar to the ones summarized in Table 9.6 on page 213.

However, notice that under a syntactic approach like Tellier's (1991) (the hypothesis that extractions out of the subject with *dont* are an exception because *dont* is special compared to *de qui*) extraction out of the subject should not be worse than extraction out of the object, and there should be no interaction between extraction type and syntactic function.

On the other hand, if this experiment reproduces the disadvantage of extractions out of the subject, that could indicate that the results of Experiment 5 are due to the animate antecedent.

### 9.3.3 Procedure

We conducted the experiment on the Ibx platform (Drummond 2010). The procedure was exactly the same as in Experiment 5. Participants rated the sentences on a Likert scale from 1 to 10, 1 being labeled as “bad” and 10 being labeled as “good”. After each sentence, participants had to answer a comprehension question. The experiment took approximately 20 minutes to complete.

### 9.3.4 Participants

The study was run between August and September 2017. We recruited the participants on the R.I.S.C. website (<http://experiences.risc.cnrs.fr/>) and on social media (e.g. Facebook).

28 participants took part in the experiment. We present the data of the 25 participants who satisfied all inclusion criteria.<sup>6</sup> The 25 participants were aged 18 to 71 years. 15 of them self-identified as women, and 10 as men. Four participants (16%) indicated having an educational background related to language.

### 9.3.5 Results and analysis

Figure 9.12 shows the results of the acceptability judgment task.<sup>7</sup> Acceptability ratings were high in all experimental conditions, with a mean rating of 9.10 for extraction out of the subject (9.17a), 8.73 for extractions out of the object (9.17b), 8.60 for the subject control (9.18a) and 8.67 for the object control (9.18b).

However, we clearly have ceiling effects in all conditions, and this is corroborated by Figure 9.13. The zROC curves in Figure 9.14 on page 225 also show that the distribution is not normal, as indicated by the fact that the lines are far from being straight.

The by-participant ratings for the extraction conditions are displayed in Figure 9.15 on page 226: it is obvious that a large proportion of the participants gave the maximum rating for the extraction conditions, regardless of the syntactic function.

---

<sup>6</sup>To calculate accuracy, we excluded not only the answers to comprehension questions of the practice items, but also one series of distractors that had an overall accuracy rate of 75% only (the same distractors that had been mentioned in the previous experiment).

<sup>7</sup>We had the same typo as in Experiment 5, so we again had to exclude the whole item from the results and treat it as a distractor. The results provided here are therefore based on 19 experimental items.

9 Empirical data on de qui relative clauses

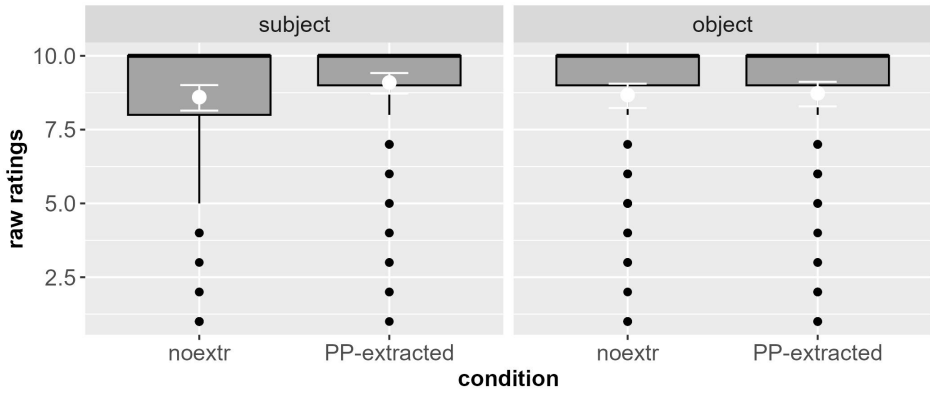

Figure 9.12: Acceptability judgments by condition in Experiment 6. The grey box plots indicate the median and quartiles of the results. Black points are outliers. Mean and confidence intervals are indicated in white.

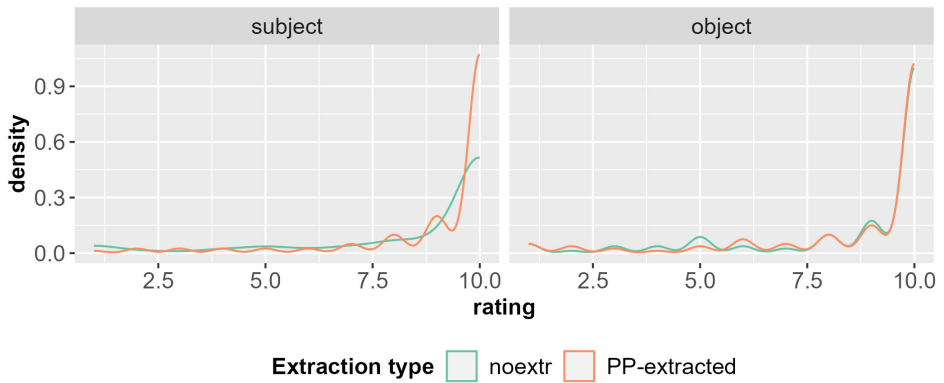

Figure 9.13: Density of the ratings across conditions for Experiment 6

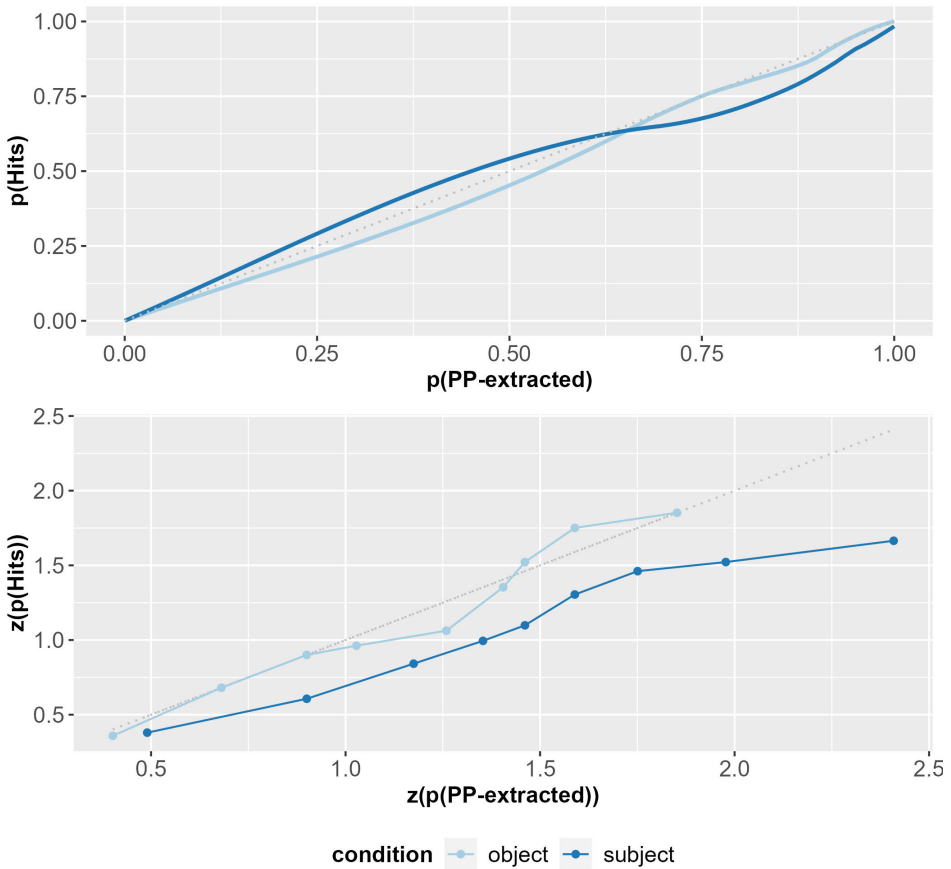

Figure 9.14: ROC curves (top) and zROC curves (bottom) of the non-extraction conditions compared to their respective subextraction condition, represented by the dotted grey baseline (Dillon & Wagers 2019's method) in Experiment 6.

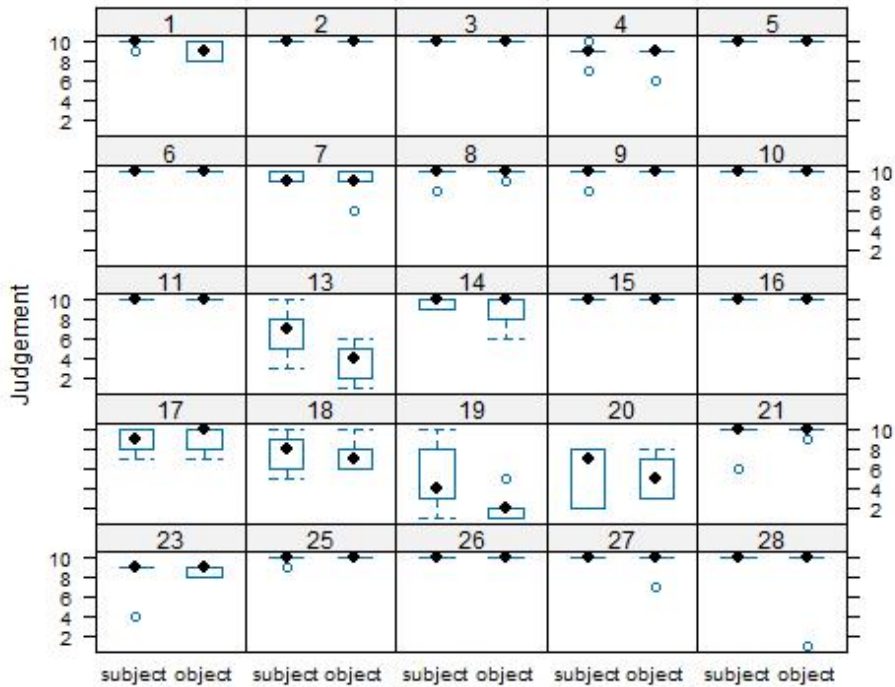

Figure 9.15: Acceptability judgments for the extraction conditions (out of subjects and out of objects) for each participant of Experiment 6. The blue box plots indicate the first and third quartiles of the results. Black points are mean ratings, and blue points are outliers.

### 9.3.5.1 Habituation

The habituation effects in the course of the experiment are shown in Figure 9.16 on page 227. As in the previous experiment, the extraction conditions show a larger habituation effect than the non-extraction conditions, but with little difference between extractions out of subjects vs. objects.

### 9.3.5.2 Comparing subextraction from the subject with subextraction from the object

We present here the results of two models. However, we have to bear in mind that the distribution is not normal, as shown above, thus the results are not very reliable.

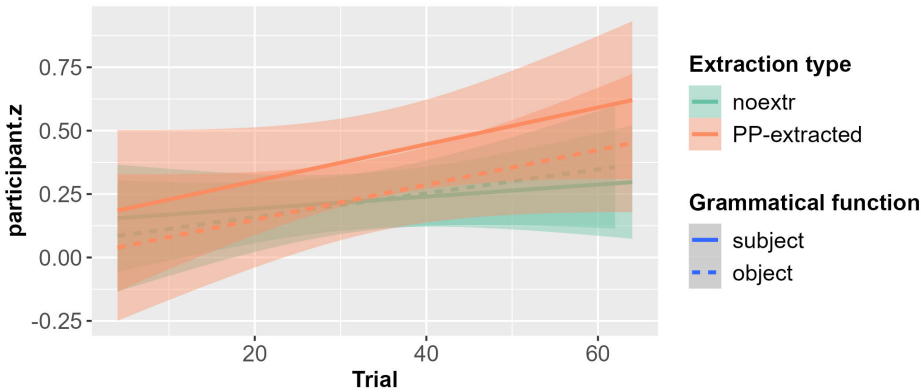

Figure 9.16: Changes in the average acceptability ratings (z-scored by participant) for each condition of Experiment 6 in the course of the experiment

We fitted a first model to compare the extractions out of the subject and out of the object on their own (mean centered with subject coded negative and object coded positive). We included trial number as a covariate, and random slopes for fixed effects and covariates grouped by participants and items. The results of the model are reported in Table 9.9. There is no significant difference between the two extractions.

Table 9.9: Results of the Cumulative Link Mixed Model (model n°1)

	Estimate	SE	$z$	$\Pr(>  z )$	Odd.ratio
syntactic function	-0.070	0.324	0	0.8286	1.07
trial	0.024	0.018	1	0.1717	1.02

In a second model, we compared subextraction with non-extraction. We fitted a model crossing syntactic function and extraction type (mean centered with extraction coded positive, non-extraction coded negative). We included trial number as a covariate, and random slopes for all fixed effects and covariates grouped by participants and items. The results of the model are reported in Table 9.10. There is a significant main effect of trial (habituation), but no other significant effect. Figure 9.17 on page 228 shows the interaction: we see a weak tendency toward an interaction effect. Furthermore, the difference in the AUC is not significant, either.

## 9 Empirical data on de qui relative clauses

Table 9.10: Results of the Cumulative Link Mixed Model (model n°2)

	Estimate	SE	z	Pr(>  z )	Odd.ratio
syntactic function	-0.201	0.201	-1	0.3193	1.22
extraction	0.132	0.271	0	0.628	1.14
trial	0.023	0.007	3	<0.005	1.02
syntactic function:extraction	-0.009	0.206	0	0.9664	1.01

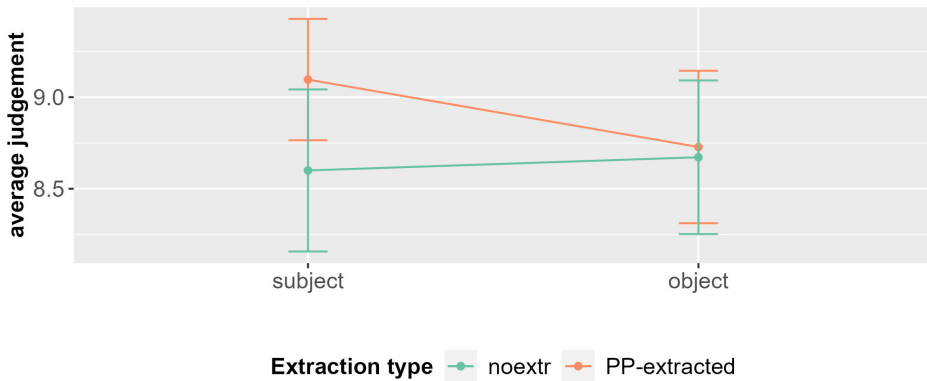

Figure 9.17: Interaction between syntactic function and extraction type in Experiment 6

### 9.3.6 Discussion

Experiment 6 is really problematic, because all ratings are very high. We can see ceiling effects (Figures 9.12 and 9.13), and visual cues of a non-normal distribution (Figure 9.14). The results of the models do not show any significant effect relevant for the hypotheses at hand. However, there is a main effect of habituation (model n°2) indicating that the model is powerful enough to identify some effects, even though the habituation effect is not very strong (odds ratio of 1.02).

Thus Experiment 6 fails to answer the question it was supposed to answer. Consequently we adopted an alternative strategy for the next experiment.



## 9.4 Experiment 7: Acceptability judgment study on *de qui* relative clauses with animate subject and object

In the sentences tested in Experiments 5 and 6, there was an animacy mismatch between the subject and the object of the relative clause. The main verb was a psych verb, with either an experiencer object (extraction out of the subject) or an experiencer subject (extraction out of the object), and the extraction always took place out of the NP denoting the stimulus. Since the stimulus was always a quality noun, it was inanimate, while the experiencer was always animate.

To my knowledge, the effect of animacy on subextractions from NPs has never been studied. However, there is some work on the effect of animacy on extraction of NPs.

For example, Gennari & McDonald (2008) ran a self-paced reading study, crossing extraction of the stimulus vs. the experiencer of psych verbs with active vs. passive voice. The object was extracted in active sentences, and the subject in passive sentences. (9.19) shows a sample item. After each trial, participants had to answer a comprehension question, targeting mostly the content of the relative clause.

- (9.19)
- a. Extraction of the experiencer (animate) + active (object)  
The director that the movie pleased \_ had received a prize at the film festival.
  - b. Extraction of the stimulus (inanimate) + active (object)  
The movie that the director watched \_ had received a prize at the film festival.
  - c. Extraction of the experiencer (animate) + passive (subject)  
The director that \_ was pleased by the movie had received a prize at the film festival.
  - d. Extraction of the stimulus (inanimate) + passive (subject)  
The movie that \_ was watched by the director had received a prize at the film festival.

They observed that reading times slows down (after *that* and until the end of the sentence) when the animate experiencer was extracted. They also observed slower reading times on the regions after the relative clause for extractions of the object experiencer (with a significant interaction effect). These results correlated with the results of comprehension questions: participants made more mistakes in extractions of the object animate experiencer (mean accuracy 69%) than in

the other conditions (mean accuracy between 81% and 84%). Animacy therefore seems to play a role in extraction, especially in an inanimate subject + animate object configuration.

We do not know how Gennari & McDonald's (2008) results transfer to subextraction. But the animacy mismatch between subject and object could have played a role in our results of Experiments 5 and 6. For this reason, Experiment 7 replicated Experiment 5 without the animacy mismatch. The results of this study have already been published in Abeillé & Winckel (2020) in a less detailed fashion.

#### 9.4.1 Design and materials

In Experiment 5, in contrast to all experiments with *dont* relative clauses, extractions out of the NP were rated relatively low compared to the baseline. However, Experiment 5 did not include ungrammatical controls to see how bad the subextraction was considered. For this reason, in Experiment 7, we used a 2\*3 design, i.e. a design very similar to Experiment 4. We compared extractions out of subjects (9.20a) with extractions out of objects (9.20b), and paired each with a non-extraction control with coordination (9.20c;9.20d) and an ungrammatical control with the preposition *de* missing (9.20e;9.20f).

- (9.20) a. Condition subject + PP-extracted:  
J' ai pris un avocat, de qui l' associé aide mon cousin  
I have taken a lawyer of who the associate helps my cousin  
sans contrepartie financière.  
without counterpart financial  
'I took a lawyer of whom the associate helps my cousin without  
financial compensation.'
- b. Condition object + PP-extracted:  
J' ai pris un avocat, de qui mon cousin aide l' associé  
I have taken a lawyer of who my cousin helps the associate  
sans contrepartie financière.  
without counterpart financial  
'I took a lawyer of whom my cousin helps the associate without  
financial compensation.'

- c. Condition subject + noextr:  
 J' ai pris un avocat, et l' associé de cet avocat aide  
 I have taken a lawyer and the associate of this lawyer helps  
 mon cousin sans contrepartie financière.  
 my cousin without counterpart financial  
 'I took a lawyer and the associate of this lawyer helps my cousin  
 without financial compensation.'
- d. Condition object + noextr:  
 J' ai pris un avocat, et mon cousin aide l' associé de  
 I have taken a lawyer and my cousin helps the associate of  
 cet avocat sans contrepartie financière.  
 this lawyer without counterpart financial  
 'I took a lawyer and my cousin helps the associate of this lawyer  
 without financial compensation.'
- e. Condition subject + ungrammatical:  
 J' ai pris un avocat, qui l' associé aide mon cousin  
 I have taken a lawyer who the associate helps my cousin  
 sans contrepartie financière.  
 without counterpart financial  
 'I took a lawyer who the associate helps my cousin without  
 financial compensation.'
- f. Condition object + ungrammatical:  
 J' ai pris un avocat, qui mon cousin aide l' associé  
 I have taken a lawyer who my cousin helps the associate  
 sans contrepartie financière.  
 without counterpart financial  
 'I took a lawyer who my cousin helps the associate without  
 financial compensation.'

Because both subject and object are animate, we used the same verb in all conditions. Many of the verbs in the relative clause were psych-verbs (e.g., *effrayer* 'scare') but not all of them (e.g., *aider* 'help'). Subject and object NPs were relational (e.g., *cousin* 'cousin', *associé* 'associate'). Complements of relational nouns are highly relevant in the sense of Chaves (2012: Section 3.1.2) because the existence of the referent they denote is presupposed by the relational noun: one can only be "cousin" with respect to someone else. The NP that should not be interpreted as containing the gap always contained a possessive determiner *mon/ma* ('my').

We tested 20 items, each containing in the six conditions already described. In addition, the experiment included 24 distractors. About one third of the items and distractors were followed by a comprehension question. The item presented here as an example was paired with the comprehension question *Cet avocat a-t-il un associé ?* ('Does this lawyer have an associate?').

### 9.4.2 Predictions

Animacy was not expected to have any impact on the acceptability of subject island structures. Therefore, the predictions were the same as those summarized in Table 9.6 on page 213.

### 9.4.3 Procedure

We conducted the experiment on the Ibex platform (Drummond 2010). The procedure was similar to the procedure used in the previous acceptability judgment experiments (see Section 8.2.3). Participants rated the sentences on a Likert scale from 0 to 10, 0 being labeled as "bad" and 10 being labeled as "good". They also answered comprehension questions after some of the sentences.

The Experiment took approximately 20 minutes to complete.

### 9.4.4 Participants

The study was run between September and October 2018. 35 participants took part in the experiment. Participants were recruited on the R.I.S.C. website (<http://experiences.risc.cnrs.fr/>) and on social media (e.g. Facebook). They received no financial compensation for taking part in the experiment.

The analysis presented here is based on the data from the 26 participants who satisfied all inclusion criteria.<sup>8</sup> The 26 participants were aged 18 to 75 years. 19 of them self-identified as women, and six as men. Five participants (20%) indicated having an educational background related to language.

---

<sup>8</sup>To calculate accuracy, we excluded not only the answers to comprehension questions of the practice items, but also the extractions out of the object, which had an overall accuracy rate of 69% only.

### 9.4.5 Results and analysis

Figure 9.18 shows the results of the acceptability judgment task.<sup>9</sup> In the subextraction conditions, the mean rating for extraction out of the subject (9.20a) was 5.15, slightly higher than extraction out of the object (9.20b) with a mean rating of 4.64. The control conditions without extraction received better acceptability judgements: 7.90 in the subject condition (9.20c) and 7.65 in the object condition (9.20d). The ungrammatical controls were rated lower: the subject condition (9.20e) has a mean rating of 3.53, and the object condition (9.20f) 3.41.

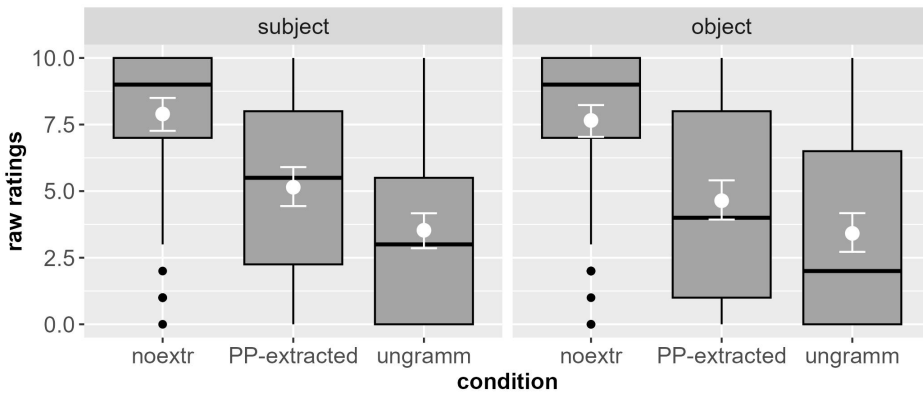

Figure 9.18: Acceptability judgments by condition in Experiment 7. The grey box plots indicate the median and quartiles of the results. Black points are outliers. Mean and confidence intervals are indicated in white.

Figure 9.18 suggests potential ceiling effects, but only in the non-extraction conditions. There is also a possible floor effect for the ungrammatical controls. Thus we have further evidence that *de qui* extractions out of NPs are judged in the middle of the scale, unlike *dont* extractions. The distribution of the ratings is illustrated by Figure 9.19: we observe a clear ceiling effect in the non-extraction conditions and a small floor effect in the ungrammatical controls. The ungrammatical object controls may show a small bimodality, with some items rated relatively high in the scale. There is no ceiling or floor effect in the subextraction conditions, but the ratings do not seem normally distributed either, as the curve is relatively flat. The *z*-scored ratings (*z*-score for each participant) in Figure 9.20

<sup>9</sup>We involuntarily introduced a typo in one condition of one experimental item. For this reason the item was excluded from the results and treated as a distractor. The results reported here are therefore based on 19 experimental items.

## 9 Empirical data on *de qui* relative clauses

show two peaks for both subextractions, suggesting bimodality. The peaks are situated to the right and left of 0. Participants seemed to classify the subextractions either as very good or very bad, but not in the middle of their scale.

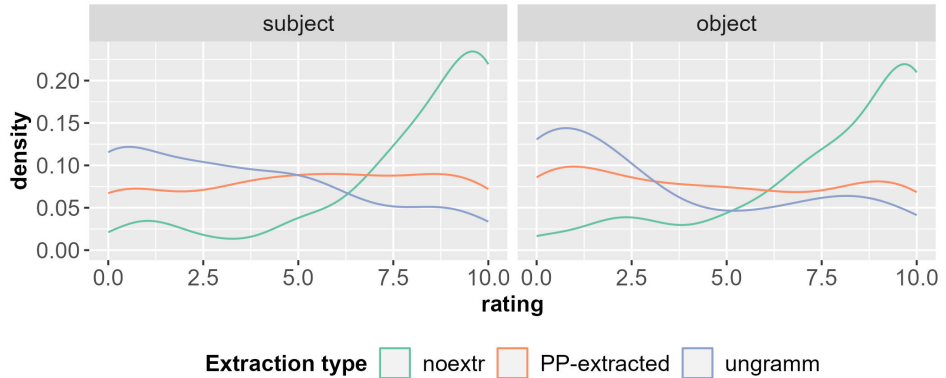

Figure 9.19: Density of the ratings across conditions for Experiment 7

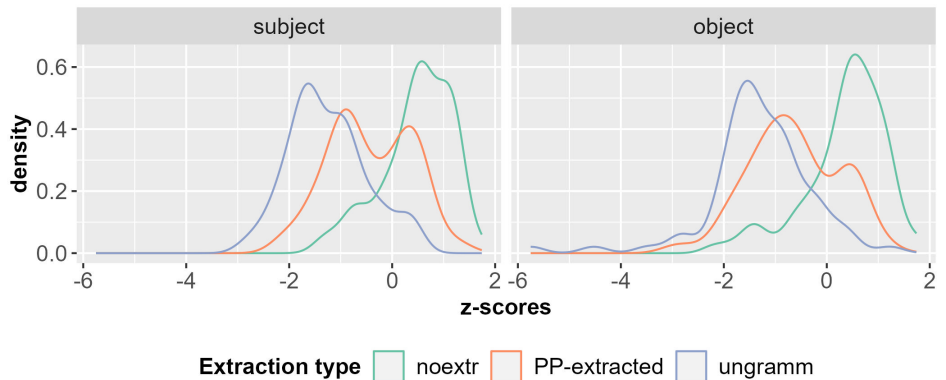

Figure 9.20: Density of the z-transformed ratings across conditions for Experiment 7

Another representation of the results is given by the ROC and zROC curves of the data in Figure 9.21. The ROC curves show that participants discriminated between the ungrammatical baselines and the other conditions. Unsurprisingly, the discrimination is stronger for the non-extraction conditions than for the subextraction conditions. The zROC curves are not very straight, which corroborates the data in Figure 9.19. Several conditions seem to have a bimodal distribution.

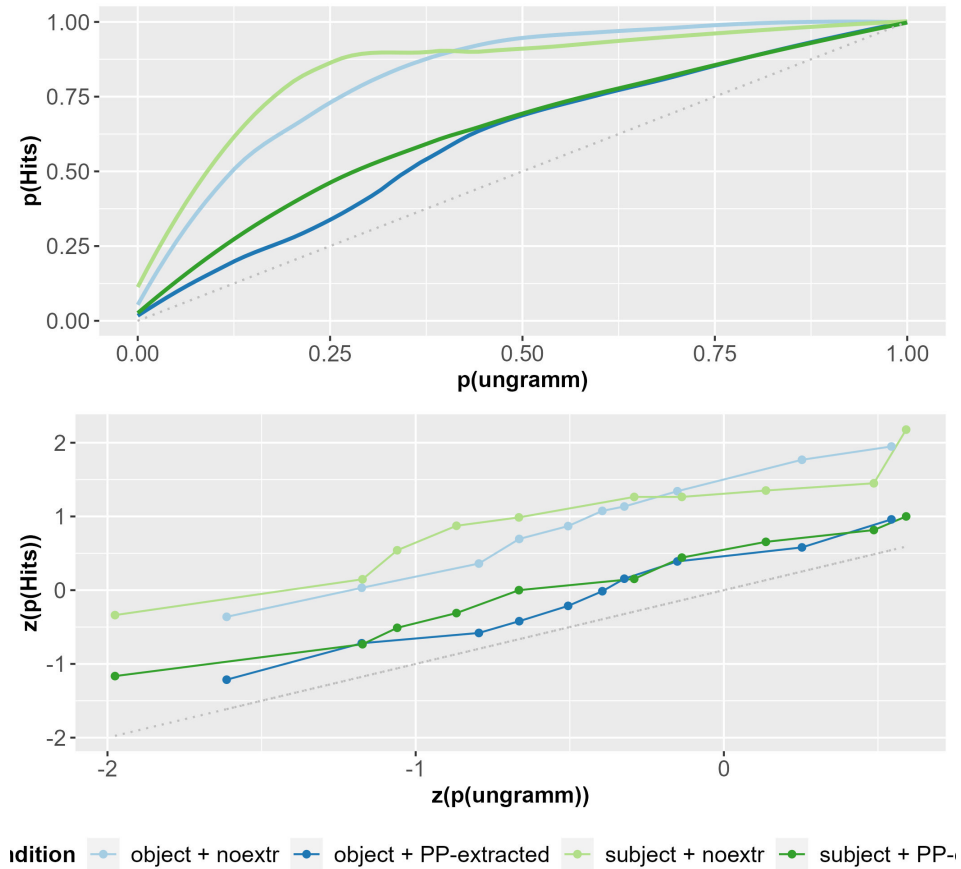

Figure 9.21: ROC curves (top) and zROC curves (bottom) for the non-extraction conditions compared to their respective subextraction conditions, represented by the dotted grey baseline (Dillon & Wagers 2019's method) in Experiment 7.

9 Empirical data on *de qui* relative clauses

The ROC and zROC curves in Figure 9.22 depict the discrimination between the subject and object conditions. The ROC curves show that the participants hardly discriminate between the subject and object conditions, but there seems to be a slight preference for the subject conditions (curves below the baseline). The zROC curves are relatively straight.

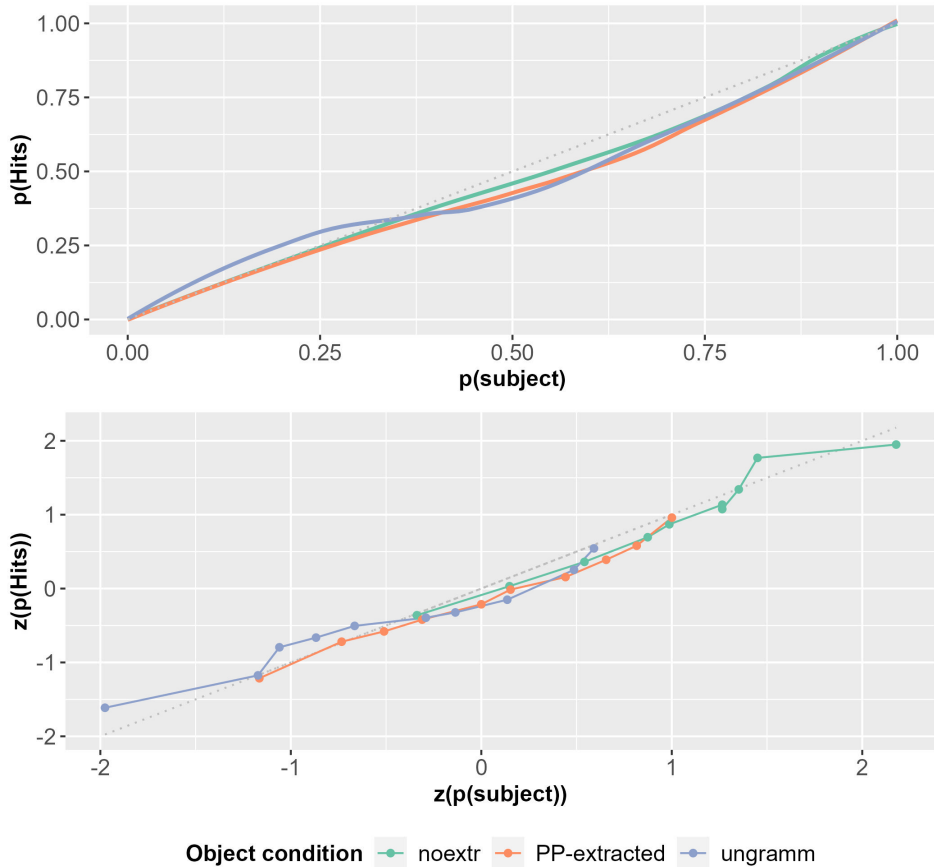

Figure 9.22: ROC curves (top) and zROC curves (bottom) for the object conditions compared to their respective subject conditions, represented by the dotted grey baseline (Dillon & Wagers 2019's method) in Experiment 7



### 9.4.5.1 Habituation

Figure 9.23 displays the habituation effects in the course of the experiment. The non-extraction conditions do not display a habituation effect, but the subextractions do. Habituation was stronger for the ungrammatical + subject control: this condition was rated very low in the early trials of the experiment, but received ratings close to those in extractions out of the object at the end of the experiment.

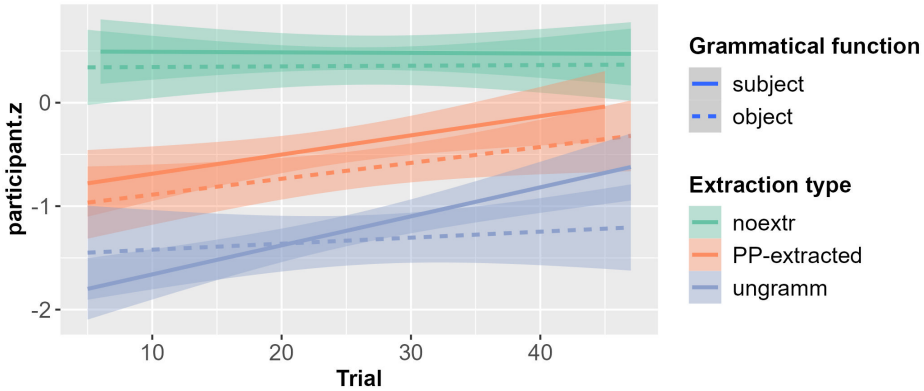

Figure 9.23: Changes in the mean acceptability ratings (z-scored by participant) for each condition of Experiment 7 in the course of the experiment

### 9.4.5.2 Comparing subextraction from the subject with subextraction from the object

Our first model compared extractions out of the subject and out of the object on their own (mean centered with subject coded negative and object coded positive). We included trial number as a covariate, and random slopes for the fixed effects grouped by participants and items. The results of the model are reported in Table 9.11. There is a significant effect of syntactic function, such that ratings for the subject condition are significantly higher than for the object condition. There is also a significant effect of trial (habituation).

In a second model, we compared subextraction with non-extraction. We fitted a model crossing syntactic function and extraction type (mean centered with extraction coded positive, non-extraction coded negative). We included trial number as a covariate, and participants and items as random factors. The results of the model are reported in Table 9.12. There is a significant main effect of syntactic function (in favor of the subject), of extraction type (in favor of the non-

9 Empirical data on de qui relative clauses

Table 9.11: Results of the Cumulative Link Mixed Model (model n°1)

	Estimate	SE	z	Pr(>  z )	Odd.ratio
syntactic function	-0.353	0.153	-2	<0.05	1.42
trial	0.036	0.013	3	<0.005	1.04

extraction controls) and of trial (habituation), but no interaction effect. If we compare the AUC (green and red curves in Figure 9.22), the difference is not significant, either. Indeed, in Figure 9.24 all lines seem almost perfectly parallel (and may be perfectly parallel without the ceiling effect in the non-extraction conditions).

Table 9.12: Results of the Cumulative Link Mixed Model (model n°2)

	Estimate	SE	z	Pr(>  z )	Odd.ratio
syntactic function	-0.225	0.112	-2	<0.05	1.25
extraction type	-1.316	0.134	-10	<0.001	3.73
trial	0.022	0.009	2	<0.05	1.02
syntactic function:extr. type	-0.079	0.110	-1	0.4747	1.08

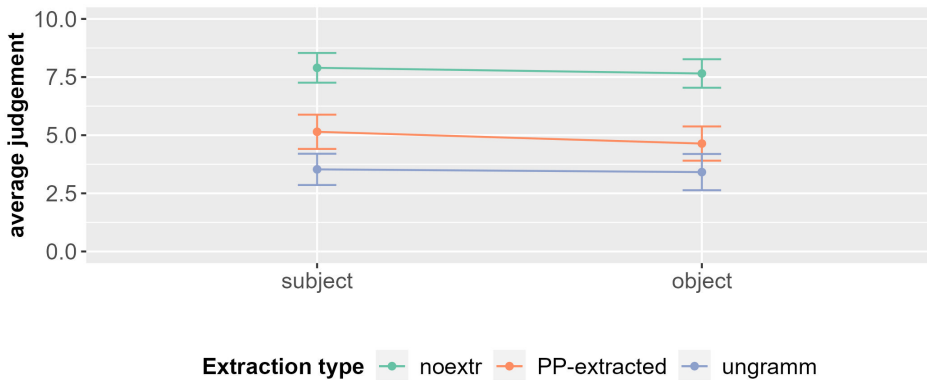

Figure 9.24: Interaction between syntactic function and extraction type in Experiment 7

### 9.4.5.3 Comparing subextraction from the subject with the ungrammatical controls

In our third model, we compared extractions out of the subject and the ungrammatical subject controls on their own (mean centered with subextraction coded positive and ungrammatical coded negative). We included trial number as a covariate, and random slopes for the fixed effects grouped by participants and items. The results of the model are reported in Table 9.13. There is a significant effect of extraction type, such that the ratings are significantly higher for extraction out of the subject than for its ungrammatical control. There is also a significant effect of trial (habituation).

Table 9.13: Results of the Cumulative Link Mixed Model (model n°3)

	Estimate	SE	$z$	$\text{Pr}( >  z  )$	Odd.ratio
extraction type	1.381	0.262	5	<0.001	3.98
trial	0.058	0.016	4	<0.001	1.06

In a fourth model, we compared the subextraction with the ungrammatical controls. The model crossed syntactic function (mean centered with object coded positive, subject coded negative) and extraction type (grammaticality). We included trial number as a covariate, and random slopes for all fixed effects grouped by participants and items. The results of the model are reported in Table 9.14. There is a significant main effect of syntactic function (in favor of the subject), of extraction type (in favor of the extraction conditions) and of trial (habituation) but no interaction effect.

Table 9.14: Results of the Cumulative Link Mixed Model (model n°4)

	Estimate	SE	$z$	$\text{Pr}( >  z  )$	OR
syntactic function	-0.265	0.122	-2	<0.05	1.30
extraction type	1.101	0.199	6	<0.001	3.01
trial	0.039	0.009	4	<0.001	1.04
syntactic function:extraction type	-0.120	0.116	-1	0.302	1.13

#### 9.4.6 Discussion

In Experiment 5, extraction out of the subject received lower ratings than extraction out of the object, with a significant interaction effect. In this experiment, extraction out of the subject received higher ratings than extraction out of the object, but there was no interaction effect. The factor that changed between Experiment 5 and the present experiment is the animacy mismatch between subject and object. Indeed, in line with Gennari & McDonald's (2008) findings, we can see that extraction of the object is judged better when the object is inanimate and the subject animate than the other way around. This could indicate a general preference for a configuration in which the subject is animate and the object inanimate, a pattern very often observed with agentive verbs, and therefore very frequent. Since extraction involves processing difficulties, it reflects this preference which is probably less apparent in ratings for easier sentences, like our grammatical controls. The significant difference that we saw in Experiment 5 can therefore be explained as a superadditive effect resulting from the processing difficulty linked to extraction on the one hand and the processing difficulty linked to the low frequency of the configuration (subject inanimate and object animate) on the other hand.

This explanation seems more adequate than one based on a syntactic subject island: if extraction out of the subject were indeed ungrammatical, the decrease in acceptability in Experiment 7 should have been much stronger. An explanation based on a superadditive processing effect linked to complex subjects is not satisfactory, either, because if that were the case then Experiment 7 should replicate the results of Experiment 5.

As far as Experiment 7 is concerned, the fact that extraction out of the subject received significantly better ratings than extraction out of the object is in contradiction with the expectations of most accounts (based on syntax and processing) that predict a superadditivity effect. The results also do not display the expected interaction effect. The fact that extraction out of the subject is significantly better than ungrammatical controls is unexpected if subjects are syntactic islands.

Both processing accounts based on memory costs and the discourse-based FBC constraint predict better acceptability ratings for extraction out of the subject than for extraction out of the object, but only processing accounts expect a significant interaction as well. The results of Experiment 7 do not falsify these two kinds of accounts.

Where does the significant difference between extraction out of the subject and out of the object come from? Figure 9.25 shows the ratings for each participant. Out of 25 participants, only five have a higher mean rating for extractions

out of objects. But the difference between subject and object is not very large, and most participants treated them similarly: The mean difference between each participant's mean ratings for extractions out of object vs. out of subject is only 0.42 (standard deviation: 1.2). Thus the participants' behavior is relatively homogeneous.

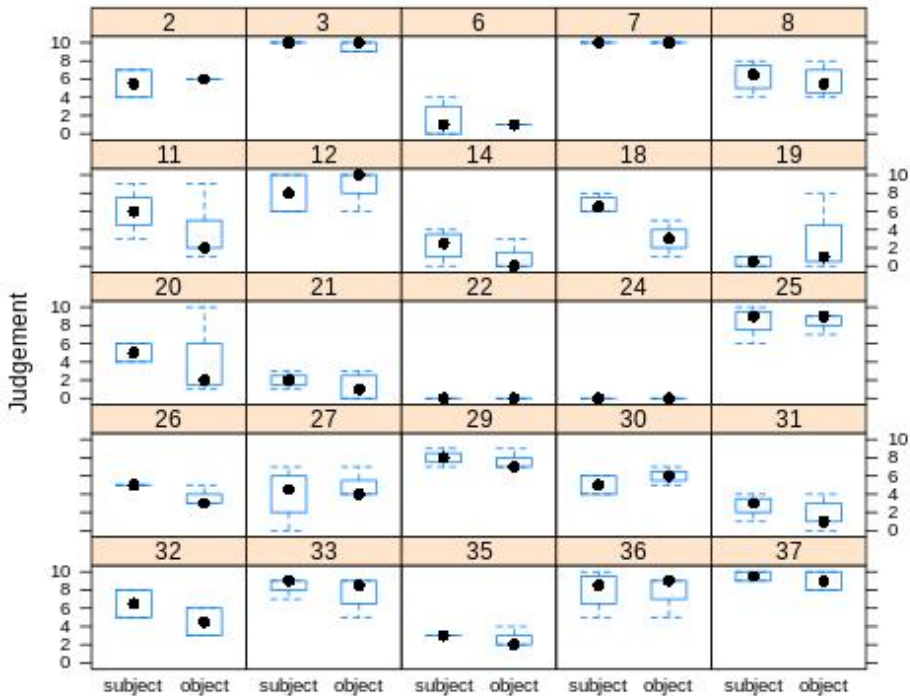

Figure 9.25: Ratings of the subextraction conditions for each participant in Experiment 7

There is a bit more variability between items. Three items show a strong preference for extraction out of the object: the mean rating for extractions out of the object is more than 2 points higher than the mean rating for extractions out of the subject. One such item is shown in (9.21):

9 Empirical data on *de qui* relative clauses

- (9.21) a. Condition subject + PP-extracted:  
J' ai un dentiste, de qui l' assistante aime bien ma mère  
I have a dentist of who the assistant likes well my mother  
malgré ses plaintes continues.  
despite her complaints perpetual  
'I have a dentist, of who the assistant likes my mother despite her  
perpetual complaints.'
- b. Condition object + PP-extracted:  
J' ai un dentiste, de qui ma mère aime bien l' assistante  
I have a dentist of who my mother likes well the assistant  
malgré ses plaintes continues.  
despite her complaints perpetual  
'I have a dentist, of who my mother likes the assistant despite her  
perpetual complaints.'

Five other items, including (9.22), show a strong preference for extraction out of the subject: the mean rating for extractions out of the subject is more than 2 points higher than the mean rating for extractions out of the object.

- (9.22) a. Condition subject + PP-extracted:  
Il y a ce collègue, de qui le stagiaire impressionne  
it there has this colleague of who the trainee impresses  
mon stagiaire pendant la préparation d' une conférence.  
my trainee during the preparation of a conference  
'There is this colleague, of who the trainee impresses my trainee  
during a conference preparation.'
- b. Condition object + PP-extracted:  
Il y a ce collègue, de qui mon stagiaire impressionne  
it there has this colleague of who my trainee impresses  
le stagiaire pendant la préparation d' une conférence.  
the trainee during the preparation of a conference  
'There is this colleague, of who my trainee impresses the trainee  
during a conference preparation.'

Most of the time, however, the difference between the two conditions is small. I was not able to identify any clear parameter to account for the variability between items.<sup>10</sup>

---

<sup>10</sup>In (9.22), the subject and the object are the same noun, but this does not seem to play a role: there are several items with the same noun for subject and object, and not all of them show a strong subject preference: in fact, one of them shows a strong object preference.

In general, the preference for extraction out of the subject over extraction out of the object seems to be a general tendency, and not an effect created by some specific items or participants. The effect size is not large (model n°1 gives an odds ratio of 1.42 for the syntactic function), as could be expected from an effect that reflects small processing preferences.

## 9.5 Experiment 8: Acceptability judgment study on *dont* relative clauses with an animate antecedent and animate subject and object

We built Experiment 8 as a parallel experiment to Experiment 7, in order to make sure that the results are similar when the relative word is *dont*.

### 9.5.1 Design and materials

We used the same stimuli and the same design as in Experiment 7, but with *dont* instead of *de qui* for the subextraction conditions. The ungrammatical controls were constructed with *que*, as in Experiment 4.

- (9.23) a. Condition subject + PP-extracted:  
 J' ai pris un avocat, dont l' associé aide mon cousin  
 I have taken a lawyer of.which the associate helps my cousin  
 sans contrepartie financière.  
 without counterpart financial  
 'I took a lawyer of which the associate helps my cousin without financial compensation.'
- b. Condition object + PP-extracted:  
 J' ai pris un avocat, dont mon cousin aide l' associé  
 I have taken a lawyer of.which my cousin helps the associate  
 sans contrepartie financière.  
 without counterpart financial  
 'I took a lawyer of which my cousin helps the associate without financial compensation.'

## 9 Empirical data on de qui relative clauses

- c. Condition subject + noextr:  
J' ai pris un avocat, et l' associé de cet avocat aide  
I have taken a lawyer and the associate of this lawyer helps  
mon cousin sans contrepartie financière.  
my cousin without counterpart financial  
'I took a lawyer and the associate of this lawyer helps my cousin  
without financial compensation.'
- d. Condition object + noextr:  
J' ai pris un avocat, et mon cousin aide l' associé de  
I have taken a lawyer and my cousin helps the associate of  
cet avocat sans contrepartie financière.  
this lawyer without counterpart financial  
'I took a lawyer and my cousin helps the associate of this lawyer  
without financial compensation.'
- e. Condition subject + ungrammatical:  
J' ai pris un avocat, que l' associé aide mon cousin  
I have taken a lawyer that the associate helps my cousin  
sans contrepartie financière.  
without counterpart financial  
'I took a lawyer that the associate helps my cousin without  
financial compensation.'
- f. Condition object + ungrammatical:  
J' ai pris un avocat, que mon cousin aide l' associé  
I have taken a lawyer that my cousin helps the associate  
sans contrepartie financière.  
without counterpart financial  
'I took a lawyer that my cousin helps the associate without  
financial compensation.'

The 20 experimental items were the same as in Experiment 7, but the distractors were different. We used 36 distractors, some of which were ungrammatical. Half of the experimental items and distractors were followed by a comprehension question. The item presented here as an example was paired with the comprehension question *Cet avocat a-t-il un associé ?* ('Does this lawyer have an associate?').

### 9.5.2 Predictions

The predictions for this experiment are similar to those for the previous experiment. They are summarized in Table 9.6 on page 213.



### 9.5.3 Procedure

We conducted the experiment on the Ibex platform (Drummond 2010). The procedure was similar to the procedure used in the previous acceptability judgment experiments (see Section 8.2.3). Participants rated the sentences on a Likert scale from 0 to 10, 0 being labeled as “bad” and 10 being labeled as “good”. They also answered comprehension questions after some of the sentences.

The experiment took approximately 20 minutes to complete.

### 9.5.4 Participants

The study was run in October 2019. Participants were recruited through FouleFactory (<https://www.foulefactory.com>), and paid 5€ for their participation. The payment was not contingent on the participants’ responses to the questions about native language or place of birth.

61 participants took part in the experiment. The analysis presented here is based on the data from the 52 participants who satisfied all inclusion criteria.<sup>11</sup> The 52 participants were aged 23 to 73 years. 29 of them self-identified as women, and 22 as men. One participant (1.92%) indicated having an educational background related to language.

### 9.5.5 Results and analysis

Figure 9.26 shows the results of the acceptability judgment task. In the subextraction conditions, extraction out of the subject (9.23a), with a mean rating of 7.68, was rated higher than extraction out of the object (9.23b) with a mean rating of 6.14. With a mean rating of 7.43, the subject control condition without extraction (9.23c) was judged a worse than the corresponding extraction. The object control condition without extraction (9.23d) was judged a bit better than the corresponding extraction with a mean rating of 6.55. The ungrammatical controls were rated very low: 1.77 in the subject condition (9.23e) and 1.98 in the object condition (9.23f).

Figure 9.26 suggests potential ceiling effects in the extraction and non-extraction conditions, especially in the subject variant. There is also a possible floor effect in the ungrammatical controls. The ratings for *dont* relative clauses are again very high, but participants seem to have used a wider range of the scale than in Experiment 6. The distribution of the ratings is illustrated by Figure 9.27: we see a clear floor effect for the ungrammatical controls, and some ceiling effects in the other conditions, but especially in the subject variants.

---

<sup>11</sup>To calculate accuracy, we excluded not only the answers to comprehension questions of the practice items and of the ungrammatical controls, but also of the ungrammatical distractors.

9 Empirical data on de qui relative clauses

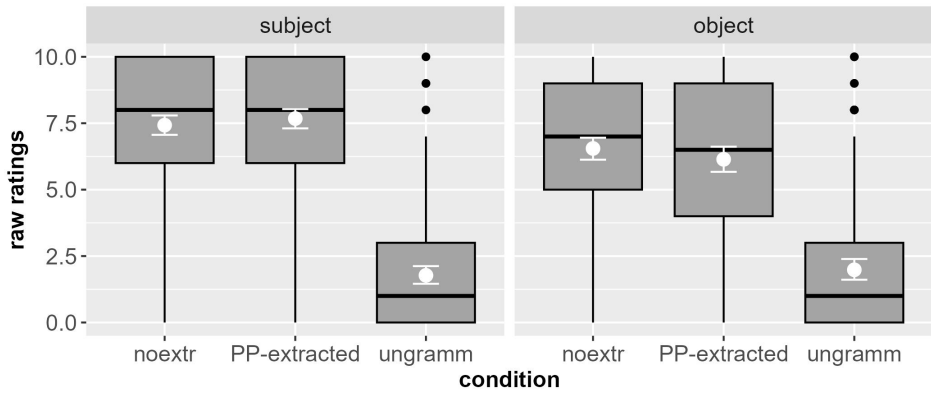

Figure 9.26: Acceptability judgments by condition in Experiment 8. The grey box plots indicate the median and quartiles of the results. Black points are outliers. Mean and confidence intervals are indicated in white.

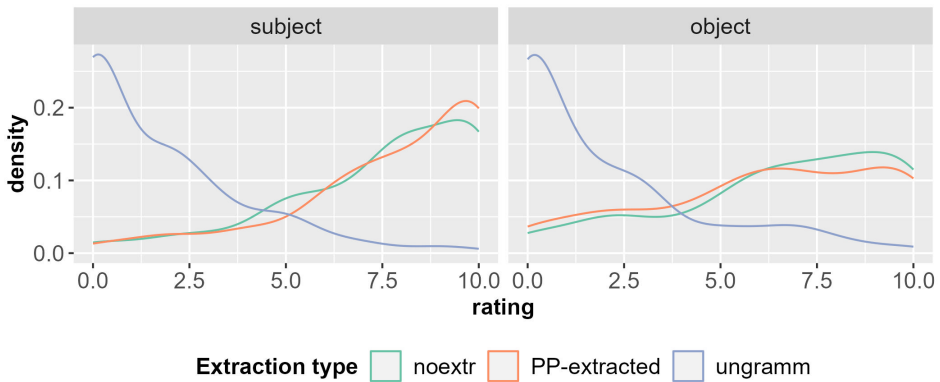

Figure 9.27: Density of the ratings across conditions for Experiment 8

Another representation of the results is given by the ROC and zROC curves of the results in Figure 9.28 on page 247. The ROC curves show that participants discriminate between ungrammatical baselines and the other conditions. We observe that the lines group by syntactic function rather than by extraction type: the subject variants build larger curves than the object variants. The zROC curves are relatively straight and parallel to the baseline.

The ROC and zROC curves in Figure 9.29 on page 248 show the discrimination between the subject and object conditions. Discrimination is almost non-existent

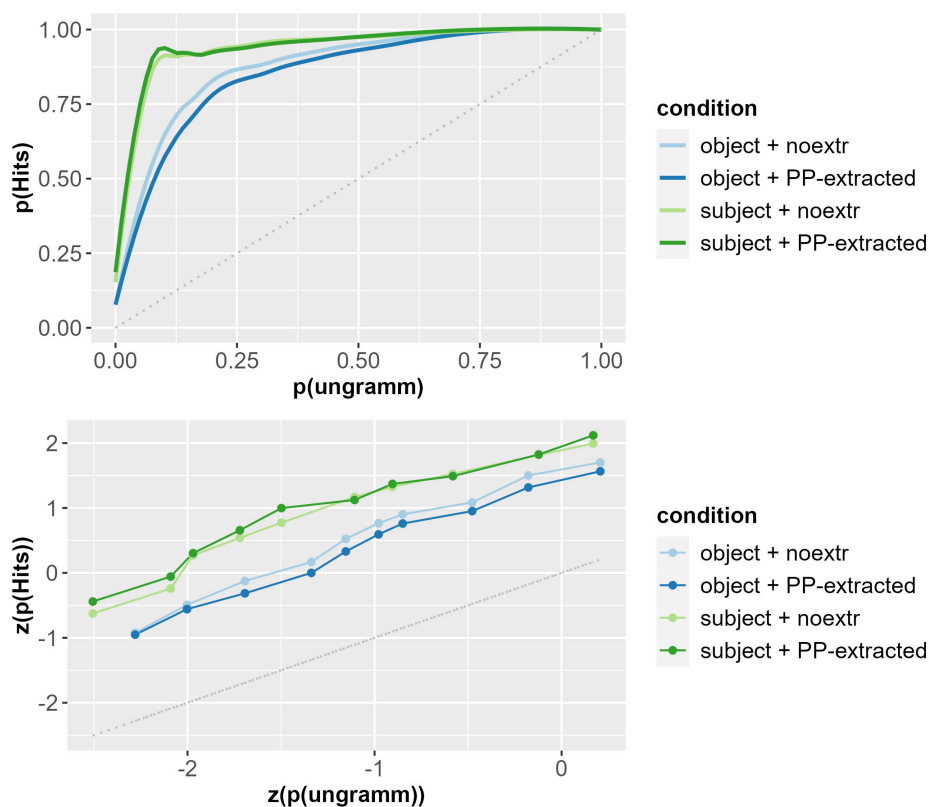

Figure 9.28: ROC curves (top) and zROC curves (bottom) of the non-extraction conditions compared to their respective subextraction conditions, represented by the dotted grey baseline (Dillon & Wagers 2019's method) in Experiment 8

in the ungrammatical controls, but more important for the two other conditions. The zROC curves are relatively straight and parallel to the baseline.

### 9.5.5.1 Habituation

The habituation effects in the course of the experiment are depicted in Figure 9.30 on page 249. We can see a slight decrease of the ratings during the experiment for extractions out of subjects. Extractions out of objects, by contrast, show a strong habituation effect. Habituation was also strong for the ungrammatical controls, but their acceptability remained very low during the whole experiment.

9 Empirical data on *de qui* relative clauses

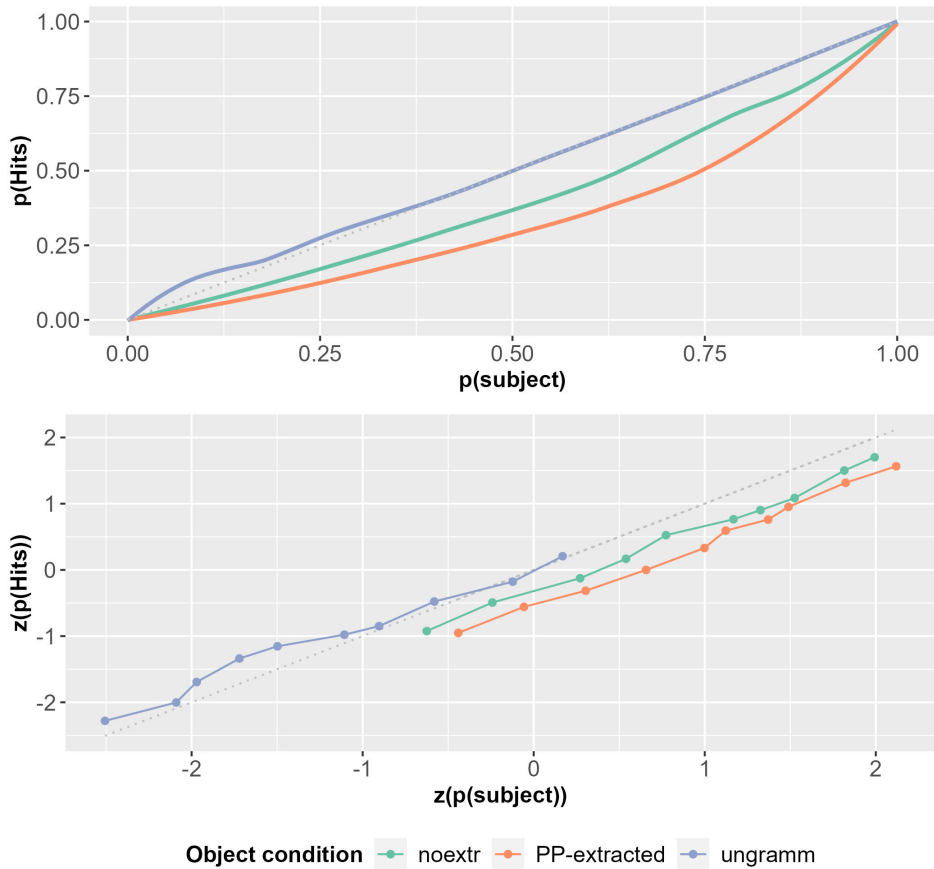

Figure 9.29: ROC curves (top) and zROC curves (bottom) of the object conditions compared to their corresponding subject condition, represented by the dotted grey baseline (Dillon & Wagers 2019's method) in Experiment 8

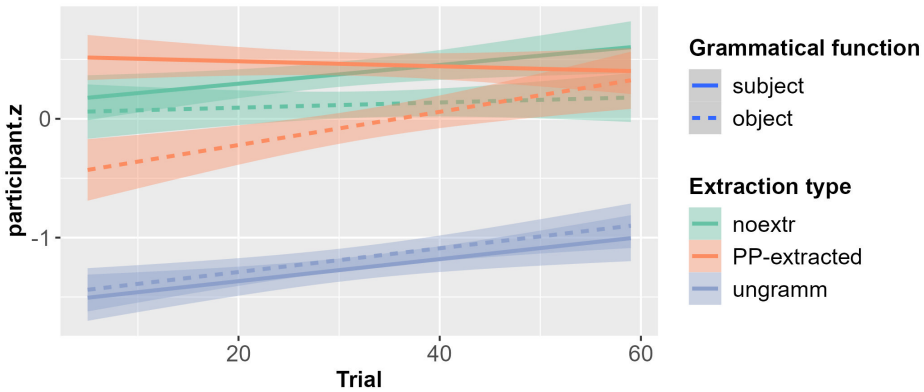

Figure 9.30: Changes in the mean acceptability ratings (z-scored by participant) by condition in Experiment 8 in the course of the experiment

### 9.5.5.2 Comparing subextraction from the subject with subextraction from the object

We fitted a first model to compare extractions out of the subject and out of the object on their own (mean centered with subject coded negative and object coded positive). We included trial number as a covariate, and random slopes for the fixed effects and covariates grouped by participants and items. The results of the model are reported in Table 9.15. There is a significant effect of syntactic function, such that the ratings in the subject condition are significantly higher than in the object condition. There is also a significant effect of trial (habituation).

Table 9.15: Results of the Cumulative Link Mixed Model (model n°1)

	Estimate	SE	z	Pr(>  z )	Odd.ratio
syntactic function	-0.818	0.146	-6	<0.001	2.27
trial	0.023	0.009	3	<0.01	1.02

A second model compared extractions out of the subject and out of the object on their own (mean centered with subject coded negative and object coded positive), but this time crossing syntactic function with trial number. We added random slopes for all fixed effects grouped by participants and items. The results of the model are reported in Table 9.16. The results are in line with model n°1, and there is no significant interaction between syntactic function and trial number.

Table 9.16: Results of the Cumulative Link Mixed Model (model n°2)

	Estimate	SE	$z$	$\Pr(>  z )$	Odd.ratio
syntactic function	-1.164	0.257	-5	<0.001	3.20
trial	0.015	0.007	2	<0.05	1.01
syntactic function:trial	0.013	0.007	2	0.0523	1.01

In a third model, we compared subextraction with non-extraction. We fitted a model crossing syntactic function and extraction type (mean centered with extraction coded positive, non-extraction coded negative). We included trial number as a covariate, and random slopes for all fixed effects and covariates grouped by participants and items. The results of the model are reported in Table 9.17. There is a significant main effect of syntactic function (in favor of the subject), and of trial (habituation) as well as a significant interaction effect. Indeed, Figure 9.31 shows that the lines cross, even though the confidence intervals overlap. However, if we compare the AUCs (green and red curves on Figure 9.29), the difference is not significant.

Table 9.17: Results of the Cumulative Link Mixed Model (model n°3)

	Estimate	SE	$z$	$\Pr(>  z )$	Odd.ratio
syntactic function	-0.686	0.120	-6	<0.001	1.98
extraction type	0.074	0.105	1	0.4828	1.08
trial	0.024	0.008	3	<0.005	1.02
syntactic function:extr. type	-0.195	0.099	-2	<0.05	1.21

### 9.5.5.3 Comparing subextraction from the subject with the ungrammatical controls

We fitted a fourth model to compare extractions out of the subject and the ungrammatical subject controls on their own (mean centered with subextraction coded positive and ungrammatical coded negative). We included trial number as a covariate, and random slopes for the fixed effects and covariates grouped by participants and items. The results of the model are reported in Table 9.18. There is a significant effect of extraction type (grammaticality), such that ratings for extraction out of the subject are significantly higher than for its ungrammatical control. There is no significant effect of trial.

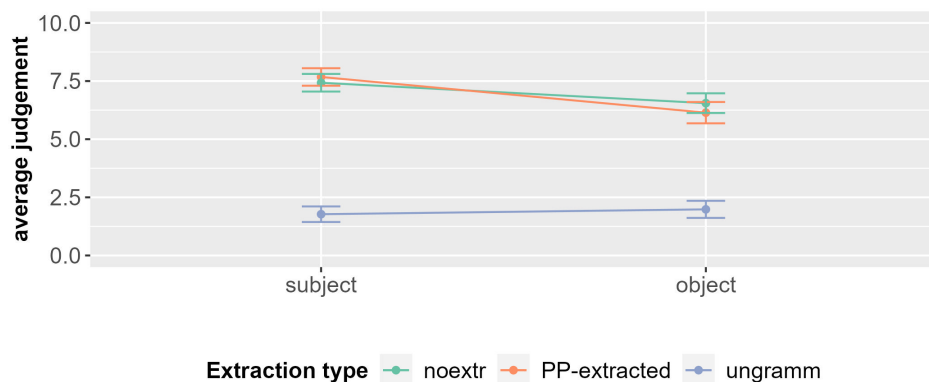

Figure 9.31: Interaction between syntactic function and extraction type in Experiment 8

Table 9.18: Results of the Cumulative Link Mixed Model (model n°4)

	Estimate	SE	z	Pr(>  z )	Odd.ratio
extraction type	3.140	0.351	9	<0.001	23.11
trial	0.013	0.009	1	0.1618	1.01

In a fifth model, we compared subextraction with the ungrammatical controls. We fitted a model crossing syntactic function (mean centered with object coded positive, subject coded negative) and extraction type (grammaticality). We included trial number as a covariate, and random slopes for all fixed effects and covariates grouped by participants and items. The results of the model are reported in Table 9.19. There is a significant main effect of syntactic function (in favor of the subject), of extraction type (in favor of the extraction conditions) and of trial (habituation). There is also a significant interaction.

### 9.5.6 Discussion

The results of Experiment 8 are generally in line with the results of Experiment 7. The general advantage for the subject variants was confirmed (main effect of syntactic function in model n°3 and n°5). This is surprising given that complex subjects are claimed to be dispreferred compared to complex objects, especially with transitive verbs (Kluender 2004).

Table 9.19: Results of the Cumulative Link Mixed Model (model n°5)

	Estimate	SE	$z$	$\Pr(>  z )$	Odd.ratio
syntactic function	-0.358	0.096	-4	<0.001	1.43
extraction type	2.529	0.270	9	<0.001	12.54
trial	0.016	0.006	3	<0.05	1.02
syntactic function:extr. type	-0.456	0.097	-5	<0.001	1.58

Participants rated extractions out of the subject significantly better than extractions out of the object in this experiment. This is again in contradiction with what we might expect from a subject island.

Whether extraction out of the object is more difficult to process is not very clear. We found a significant interaction in model n°3, but the more conservative method of comparing the AUCs did not yield a significant difference.

Once again, we find some variability between participants and between items. No item showed a strong preference for extraction out of the object over extraction out of the subject, but many items showed a strong preference in the other direction: the mean rating for extractions out of the subject was more than 2 points higher than the mean rating for extractions out of the object). These items, however, were not necessarily the ones that showed a strong preference for extraction out of the subject in Experiment 7. I conclude that there is no evidence that some items are biased toward one or the other subextraction type, and that the variation between items is probably random.

## 9.6 Experiment 9: Self-paced reading study on *de qui* relative clauses with an animate antecedent and animate subject and object

This experiment is an online study variant of Experiment 7. Our goal was to see how participants process subextractions from subjects and objects.

### 9.6.1 Design and materials

We used materials (items and distractors) similar to those in Experiment 7.<sup>12</sup> We made some small changes in order to avoid repetition within the same sentence

<sup>12</sup>More exactly, Experiment 7 was intended as a calibration study for the self-paced reading Experiment 9.



(e.g. *de qui les étudiants étonnent mes étudiants* ‘of who the students astonish the students’) and to match the length of the subject and object nouns (with +/- one character). As in Experiment 7, we compared extractions out of subjects (9.24a) with extractions out of objects (9.24b), and paired each of them with a coordination (9.24c;9.24d) and an ungrammatical control with the preposition *de* missing (9.24e;9.24f). The square brackets indicate the regions (i.e., groups of words) that were presented together on the screen:

- (9.24) a. Condition subject + PP-extracted:  
 [J' ai pris]<sub>1</sub> [un avocat]<sub>2</sub> [de qui]<sub>3</sub> [le confrère]<sub>4</sub> [aide]<sub>5</sub>  
 I have taken a lawyer of who the colleague helps  
 [mon parrain]<sub>6</sub> [sans]<sub>7</sub> [contrepartie]<sub>8</sub>.  
 my godfather without counterpart  
 ‘I took a lawyer of who the colleague helps my godfather without compensation.’
- b. Condition object + PP-extracted:  
 [J' ai pris]<sub>1</sub> [un avocat]<sub>2</sub> [de qui]<sub>3</sub> [mon parrain]<sub>4</sub> [aide]<sub>5</sub> [le  
 I have taken a lawyer of who my godfather helps the  
 confrère]<sub>6</sub> [sans]<sub>7</sub> [contrepartie]<sub>8</sub>.  
 colleague without counterpart  
 ‘I took a lawyer of who my godfather helps the colleague without compensation.’
- c. Condition subject + noextr:  
 [J' ai pris]<sub>1</sub> [un avocat]<sub>2</sub> [et]<sub>3</sub> [son confrère]<sub>4</sub> [aide]<sub>5</sub> [mon  
 I have taken a lawyer and his colleague helps my  
 parrain]<sub>6</sub> [sans]<sub>7</sub> [contrepartie]<sub>8</sub>.  
 godfather without counterpart  
 ‘I took a lawyer and his colleague helps my godfather without compensation.’
- d. Condition object + noextr:  
 [J' ai pris]<sub>1</sub> [un avocat]<sub>2</sub> [et]<sub>3</sub> [mon parrain]<sub>4</sub> [aide]<sub>5</sub> [son  
 I have taken a lawyer and my godfather helps his  
 confrère]<sub>6</sub> [sans]<sub>7</sub> [contrepartie]<sub>8</sub>.  
 colleague without counterpart  
 ‘I took a lawyer and my godfather helps his colleague without compensation.’

- e. Condition subject + ungrammatical:  
[J' ai pris]<sub>1</sub> [un avocat]<sub>2</sub> [qui]<sub>3</sub> [le confrère]<sub>4</sub> [aide]<sub>5</sub> [mon  
I have taken a lawyer who the colleague helps my  
parrain]<sub>6</sub> [sans]<sub>7</sub> [contrepartie]<sub>8</sub>.  
godfather without counterpart  
'I took a lawyer who the colleague helps my godfather without  
compensation.'
- f. Condition object + ungrammatical:  
[J' ai pris]<sub>1</sub> [un avocat]<sub>2</sub> [qui]<sub>3</sub> [mon parrain]<sub>4</sub> [aide]<sub>5</sub> [le  
I have taken a lawyer who my godfather helps the  
confrère]<sub>6</sub> [sans]<sub>7</sub> [contrepartie]<sub>8</sub>1.  
colleague without counterpart  
'I took a lawyer who my godfather helps the colleague without  
compensation.'

About a third of the experimental items and distractors were followed by a comprehension question.

### 9.6.2 Experimental method

Self-paced reading tasks were first introduced by Just et al. (1982). As in eye tracking experiments, the underlying assumption is that participants' reading pace slows down (and hence their reading time increases) when they are having difficulty processing a sentence chunk. The methodology is therefore comparable to eye tracking experiments, but with only one type of reaction times.

In a self-paced reading experiment, sentences are presented as a series of smaller segments appearing one at a time. Participants control the reading pace by pressing a key or button to get from one region to the next. In contrast to eye tracking experiments (Section 8.4), participants cannot compensate for memory difficulties by going back to a previous part of the sentence. Difficulties in retrieving the filler's information, integration problems, or difficulties with an improbable gap site are assumed to be reflected in longer reading times.

### 9.6.3 Predictions

In general, all accounts assume that subextractions induce more processing costs than non-subextractions. Therefore, when examining the extraction conditions vs. the non-extraction conditions, we expect to see a penalty on the reading times

for the subject in (9.24a) compared to (9.24c), and for the object in (9.24b) compared to (9.24d). As we will see, there is one exception to this prediction.

It is not entirely clear what reading time effects to expect under accounts that predict a penalty for extracting out of the subject. Syntactic approaches assume that readers do not attempt to posit a gap inside the subject, because they know that it would be ungrammatical. Readers should also not attempt to posit a gap inside the subject under processing accounts based on subject complexity. According to Kluender (2004), complex subjects are not frequent and thus a gap in this position is not expected. However, the same cause can lead to two different scenarios.

The first scenario is the following: Readers are surprised to find a gap in the subject that they did not anticipate. The consequence is that reading times for extractions out of the subject increase more than reading times for extractions out of the object, resulting in an interaction effect. In reference to Hale's (2001) notion of surprisal, I call this the "surprisal" scenario.

In the second scenario, at the subject, readers do not posit any gap, because it is highly improbable. At this point, they expect to encounter a gap later. The consequence is that there is no increase in reading time on the subject for (9.24a) compared to (9.24c). This is the approach of Yoshida et al. (2014). It predicts an interaction effect, such that extraction out of the object (9.24b) leads to longer reading times than the other conditions (9.24a), (9.24c) and (9.24d). The processing difficulty caused by the subextraction from the subject may arise at the end of the sentence, as readers still have an unintegrated filler in memory, because *de qui* in (9.24a) can neither be the complement of the object noun nor of the verb. I call this the "giving up" scenario.

Under a processing account based on memory costs, when readers encounter the filler, they will anticipate a gap at the closest possible site, i.e. in the subject. In the condition with subextraction out of the subject (9.24a), this expectation is met. When subextraction takes place out of the object (9.24b), the reader has to revise this prediction and posit another gap at the closest possible site. This results in filled-gap effects on the subject (see Section 3.1 about filled-gap effects). The consequence is that reading times for extractions out of the object increase more than reading times for extractions out of the subject in this region. I call this the "asap" scenario.

An account based on the FBC constraint expects no special behavior in subject vs. object subextractions: reading times for extractions out of the object should increase as much as reading times for extractions out of the subject. I call this the "nothing to report" scenario.

Before we look at the results of the experiment, it is important to note that reading time data are very messy, and difficult to interpret. The predictions of the different scenarios described above are themselves debatable, because they are much too simple and cannot reflect every processing factors that should be considered when trying to explain the results. However, they are the only way to prevent post hoc explanations of the observed results.

#### 9.6.4 Procedure

The experiment was conducted at the Laboratoire de Linguistique Formelle (LLF) in the Université Paris Cité. The investigators were Aixiu An and myself. The experiment was run on E-Prime experimental software (Psychology Software Tools, Pittsburgh, PA). Testing was done individually.

The participants received written instructions and gave informed consent. Before the actual experiment, participants provided information on their linguistic background. These information forms were treated anonymously during data processing.

Sentences were presented one region at a time on a computer screen, with the other missing words of the sentence replaced by placeholders. Participants would press a button to proceed to the next chunk of words corresponding to the next region. They were instructed to read the sentence as fast as possible while maintaining good comprehension. At the end of each sentence, they would press a button to move on. In some trials, a comprehension question would appear on the screen related to the sentence just read. Participants responded to it by choosing one of two possible answers on the screen. We used a Latin square design, such that each participant saw each item and distractor in only one condition. The items were pseudo-randomized, to avoid having two items in the same condition or two non-distractors following each other.

The experiment lasted approximately 20 minutes. At the end, participants were debriefed and they received a payment of 8€.

#### 9.6.5 Participants

The study was run between November 2018 and February 2019. Participants were recruited on the R.I.S.C. website (<http://experiences.risc.cnrs.fr/>) and on social media (e.g. Facebook).

48 participants took part in the experiment, all monolingual native speakers of French. They all had more than 75% accuracy in the comprehension questions.<sup>13</sup> Data from all 48 participants were included in the analysis.

### 9.6.6 Results and analysis

We excluded outliers for every region: taking only the experimental items into account (i.e. ignoring practice items and distractors that have very different regions), we calculated each participant's mean and standard deviation and excluded reading times that were over 3 standard deviations from the mean; we also calculated for each condition the mean and standard deviation and excluded reading times that were over 3 standard deviations from the mean.

The distribution of the reading times is not normal. For this reason, we log-transformed them using the function  $\log()$  in R (R Core Team 2018), to get a distribution closer to normal. The data shown in the graphs are log-transformed reading times by character, i.e. the total reading time on a region divided by the number of characters and then log-transformed.

Figure 9.32 display the reading times across regions. We can see that the non-extraction conditions were generally read more quickly than the extraction conditions, whereas the ungrammatical conditions were read more slowly. There is also more variation between conditions in regions 3 and 6, where the words differ. Regions 1 and 2 show some variation as well, which can only be noise given that the condition did not differ. The variation across extraction types in region 3 is probably an artefact of the important difference in length (e.g. *et* vs. *de qui*). On regions 4 (subject of the relative) and 5 (verb of the relative), the subject conditions were read more slowly than the object conditions (except for the ungrammatical control, where subject and object conditions are almost indistinguishable). On region 6 (object of the relative) however, the reading times for the object conditions increase. In this respect, we see no obvious difference between subextraction and anaphoric binding (linking the possessive article to his antecedent). Figure 9.33 shows regions 4–6 in more detail in the non-extraction and subextraction conditions.

---

<sup>13</sup>To calculate accuracy, we excluded the answers to comprehension questions of the practice items and of the ungrammatical conditions (9.24e) and (9.24f).

9 Empirical data on de qui relative clauses

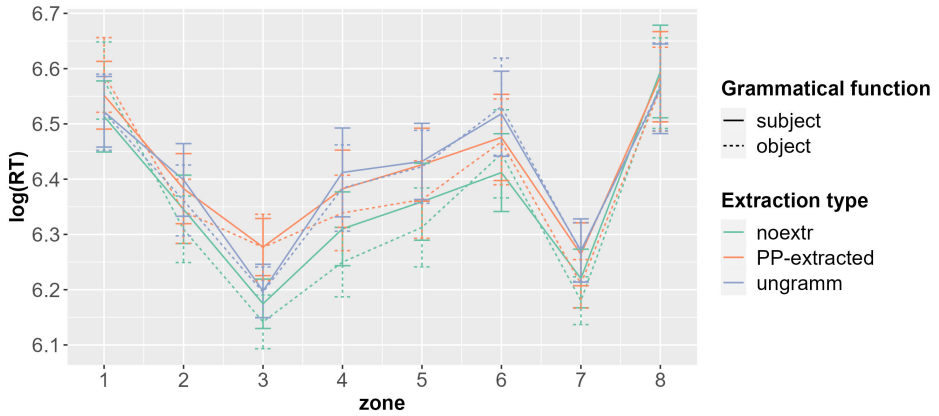

Figure 9.32: Mean log-transformed reading times by character by condition in Experiment 9 (regions = 1: matrix clause; 2: antecedent; 3: relative phrase/coordination; 4: Subject; 5: Verb; 6: Object, 7: 1st part of AdvP, 8: 2nd part of AdvP)

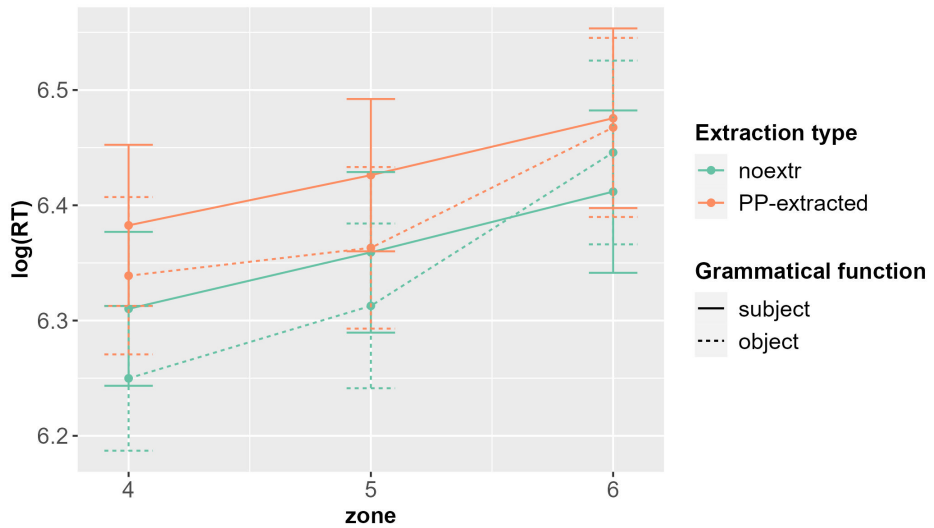

Figure 9.33: Mean log-transformed reading times by character for the grammatical conditions of Experiment 9 (regions 4–6 only) (Regions = 4: Subject; 5: Verb; 6: Object)

### 9.6.6.1 Effect of frequency

We assigned a frequency value to regions 4–6 based on the frequency of the head noun for regions 4 and 6 and the frequency of the verb for region 5. The frequency value was taken from *lexique.org*.<sup>14</sup> Frequencies, like the reading times, are not normally distributed, so we used the log-transformed frequency.

The effect of frequency on the different conditions is shown in Figure 9.34 (for the sake of clarity, the figure does not include the ungrammatical controls). There is a general impact of frequency on reading times: more frequent words are read more quickly. This effect seems stronger for the subject conditions (which, as we have seen, have longer reading times) than for the object conditions.

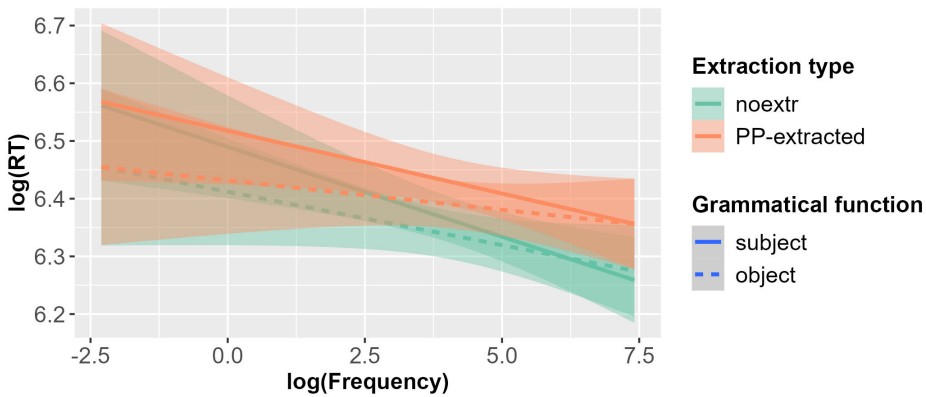

Figure 9.34: Changes in the reading times (log-transformed reading times by character) depending on the frequency (log-transformed frequency) for subextraction and non-extraction conditions of Experiment 9

Considering only the subextraction site (i.e. only the two subextraction conditions, and the reading times on region 4 for extraction out of subject and on region 6 for extraction out of object), we fitted a first model crossing syntactic function (mean centered with subject coded positive and object coded negative) and log-transformed frequency. The variable to be explained are log-transformed reading times. We included characters (the number of characters in the region), participants and items as random factors. The results of the model are reported in Table 9.20. There is a significant main effect of frequency, but no interaction effect; the frequency effect on the extraction site is not significantly different in extractions out of the subject and extractions out of the object.

<sup>14</sup>The Lexique database was implemented by Boris New and Christophe Pallier. We used the frequency of the lemma, called `freqlemfilm2` and based on the frequency in French subtitles.

Table 9.20: Results of the Linear Mixed-Effects Model (model n°1)

	Estimate	SE	df	<i>t</i>	Pr(>   <i>t</i>  )	OR
(Intercept)	6.540	0.070	124.7	93	<0.001	692.40
syntactic function	-0.046	0.051	266.9	-0.90	0.3689	1.05
frequency	-0.025	0.011	262.3	-2.28	0.0231	1.03
syn. function:freq.	-0.001	0.011	265.9	-0.11	0.9128	1.00

### 9.6.6.2 Effect of extraction on the extraction site

Turning to the subject (region 4), we fitted a second model to compare the extractions out of the subject with their non-extraction controls (mean centered with subextraction coded negative and non-extraction coded positive). We included log-transformed frequency as a covariate, and characters, participants and items as random factors. The results of the model are reported in Table 9.21. There is a significant main effect of frequency, but no effect of extraction type. Non-extractions were read more quickly, but not significantly more quickly, than the subextractions.

Table 9.21: Results of the Linear Mixed-Effects Model (model n°2)

	Estimate	SE	df	<i>t</i>	Pr(>   <i>t</i>  )	OR
(Intercept)	6.481	0.073	37.8	89	<0.001	652.79
extraction type	-0.035	0.021	25.0	-2	0.1132	1.04
frequency	-0.033	0.013	21.4	-2	<0.05	1.03

We fitted a third model to compare the extractions out of the object with their non-extraction controls (mean centered with subextraction coded negative and non-extraction coded positive), i.e. on region 6. We included log-transformed frequency as a covariate, and characters, participants and items as random factors. The results of the model are reported in Table 9.22. There is no significant difference between the subextraction and its non-extraction control. Again, non-extractions were read more quickly, but not significantly more quickly, than the subextractions.



Table 9.22: Results of the Linear Mixed-Effects Model (model n°3)

	Estimate	SE	df	<i>t</i>	Pr(>   <i>t</i>  )	OR
(Intercept)	6.590	0.088	44.9	75	<0.001	728.01
extraction type	-0.020	0.020	100.6	-1	0.3046	1.02
frequency	-0.026	0.015	19.2	-2	0.0967	1.03

### 9.6.6.3 Do reading times for extraction out of the subject increase more/less than reading times for extraction out of the object? (“surprisal” and “giving up” scenarios)

In a fourth model, we compared the two extraction sites: region 4 for extractions out of the subject and their non-extraction control, and region 6 for extractions out of the object and their non-extraction control. We fitted a model crossing syntactic function (mean centered with subject coded positive and object coded negative) and extraction type (mean centered with extraction coded positive and non-extraction coded negative). We included log-transformed frequency as a covariate, and characters, participants and items as random factors. The results of the model are reported in Table 9.23. There is a significant main effect of syntactic function (objects were read more slowly), and a significant main effect of frequency. In line with models n°2 and n°3, there is no significant main effect of extraction type. There is also no significant interaction. Figure 9.35 shows the interaction with only a small tendency toward an interaction effect.

Table 9.23: Results of the Linear Mixed-Effects Model (model n°4)

	Estimate	SE	df	<i>t</i>	Pr(>   <i>t</i>  )	OR
(Intercept)	6.525	0.060	52.8	108	<0.001	681.69
extraction type	-0.025	0.014	551.8	-2	0.0788	1.03
syntactic function	-0.064	0.014	556.7	-5	<0.001	1.07
frequency	-0.028	0.009	18.0	-3	<0.01	1.03
extr. type:syn. fun.	-0.011	0.014	560.1	-1	0.4381	1.01

## 9 Empirical data on *de qui* relative clauses

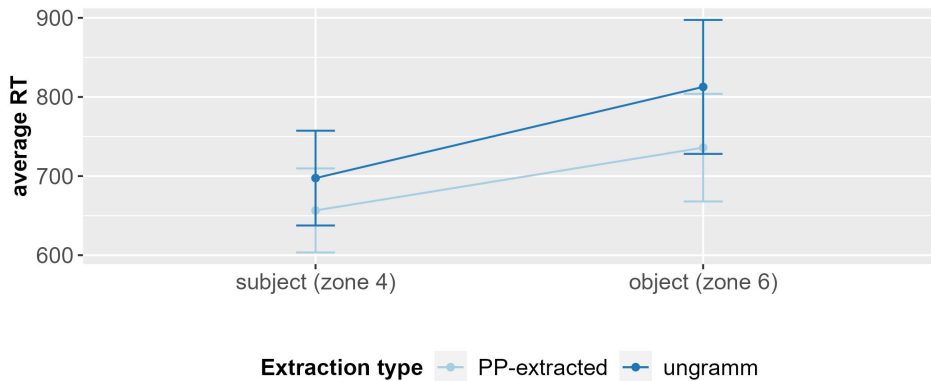

Figure 9.35: Interaction between syntactic function and extraction type on the respective extraction site in Experiment 9. Reading times are indicated as log-transformed reading times by character.

### 9.6.6.4 Do reading times for extraction out of the object increase more than reading times for extraction out of the subject in region 4? (“asap” scenario)

In a fifth model, we compared the difference between the subextractions and their respective non-extraction controls in region 4. We fitted a model crossing syntactic function (mean centered with subject coded positive and object coded negative) and extraction type (mean centered with extraction coded positive and non-extraction coded negative). We included log-transformed frequency as a covariate, and characters, participants and items as random factors. The results of the model are reported in Table 9.24. There is a significant main effect of extraction type (subextractions were read more slowly), and a significant main effect of frequency. There is no significant main effect of extraction type, and no significant interaction. The non-significant interaction can be seen in Figure 9.36: the lines are perfectly parallel.

### 9.6.7 Discussion

Even though participants discriminated strongly between subextractions with *de qui* and their non-extraction controls, we could not find any strong effect due to the subextraction itself in reading times (models n°2, n°3 and n°4). One possible explanation may lie in our non-extraction control, which involved a coordination with anaphoric binding (the possessive article). Keshev & Meltzer-Asscher (2019: 641) conducted an experiment on anaphoric binding, using Sprouse et al.’s

Table 9.24: Results of the Linear Mixed-Effects Model (model n°5)

	Estimate	SE	df	<i>t</i>	Pr(>   <i>t</i>  )	OR
(Intercept)	6.426	0.056	75.5	114	<0.001	617.90
extraction type	-0.043	0.016	18.8	-3	<0.05	1.04
syntactic function	0.014	0.013	373.8	1	0.2850	1.01
frequency	-0.023	0.008	44.9	-3	<0.01	1.02
extraction type:syntactic function	0.007	0.013	507.3	1	0.5945	1.01

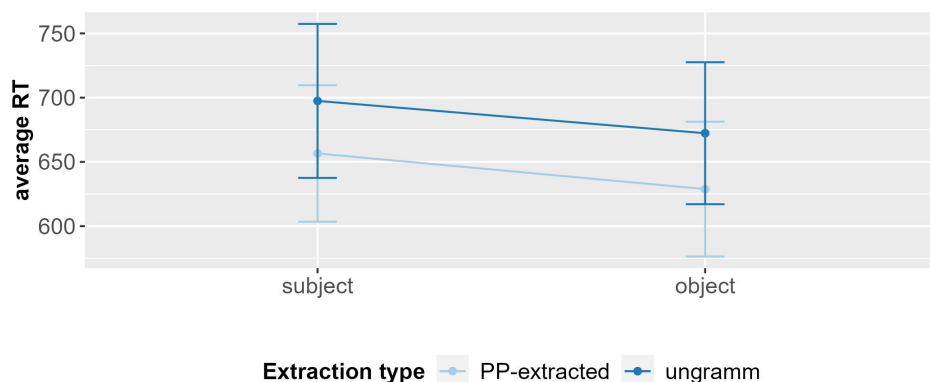

Figure 9.36: Interaction between syntactic function and extraction type in region 4 (subject of the relative) in Experiment 9. Reading times are indicated as log-transformed reading times by character.

superadditivity design for islands and found a marginal interaction effect ( $p = 0.08$ ). The retrieval costs for anaphoric binding may have canceled out the costs of extraction in our design. This was not an issue in Experiment 7, where the non-extraction controls were complex NPs with non-anaphoric *de*-complements.

In Experiment 9, we failed to find statistically significant evidence for any of the differences expected under the different scenarios. Perhaps we find ourselves in the “nothing to report” scenario, where, indeed, no difference is expected apart from the difference between extraction and non-extraction. However, it could also be the case that the experiment just did not have enough participants to detect significant effects.

## 9 *Empirical data on de qui relative clauses*

To conclude, none of the scenarios we have presented in the prediction section was falsified by the experiment. The least probable is, however, the “surprisal” scenario, whose predictions are the opposite of the tendency in Figure 9.35.

This experiment shows that, if there is any effect of subextraction out of the subject on reading times, this effect is subtle. Under the assumption that reading times and acceptability ratings correlate to a certain degree, the results are in line with those of the previous experiments on relative clauses.

# 10 Corpus studies on other relative clauses

In this chapter, I present two corpus studies.

*Corpus studies on duquel*: Data from Frantext show that *duquel* is mostly used in relative clauses. Since it primarily occurs in pied-piping structures, there are only few cases of extraction out of NPs. Still, extraction out of subjects is attested.

*Corpus studies on avec + wh-*: In both relative clauses and interrogatives, *avec + wh-* is mostly used as a complement of the verb or as an adjunct. Extraction out of NPs is rare in relative clauses and not attested for interrogatives. Even though we found more extractions out of objects than extractions out of subjects in relative clauses, the numbers are too low to conclude that this difference is a robust one.

## 10.1 Corpus study on *duquel*

### 10.1.1 Motivation

We have seen that extraction out of the subject is frequent in *de qui* relative clauses, but not attested in *de qui* interrogatives. The filler *duquel* (lit. ‘of the which’) can also be used for extracting *de*-PPs. If the contrast between relative clauses and interrogatives is robust, we expect to find many cases of extraction out of the subject in *duquel* relative clauses as well.

### 10.1.2 Procedure

As in the previous studies, we used the Frantext corpus (ATILF et al. 2016). As we found no evidence for a major change since 1900, we only looked at texts in Frantext published between 2000 and 2013 (222 texts, about 13.3 million tokens).

The lemma *duquel* can be realized in four forms: *duquel* (masculine singular), *de laquelle* (feminine singular), *desquels* (masculine plural or masculine+feminine

plural) and *desquelles* (feminine plural). In Frantext, *duquel*, *desquels* and *desquelles* are tagged under the lemma “*duquel*”, but *de laquelle* is tagged as two different lemmas “*de*” and “*lequel*” (lit. ‘the which’). For this reason, we ran two different queries, one with the lemma “*duquel*” and one with the words “*de laquelle*”. In the following, we combine the results of the two queries as a single corpus study.

The two queries combined yield 955 occurrences of *duquel*, which we annotated the same way as in the previous corpus studies. The results confirm that *duquel* is mostly used in relative clauses, but also show that it may occur in interrogatives. There are 941 relative clauses with an antecedent, seven direct and indirect questions and four *c’est*-clefts. The three remaining occurrences are noise, i.e. passages written in non-contemporary French.

The seven interrogatives (three direct questions and four indirect questions) are too few to draw any meaningful conclusions. Notice however that there is no example of extraction out of the subject (see Figure 10.1).

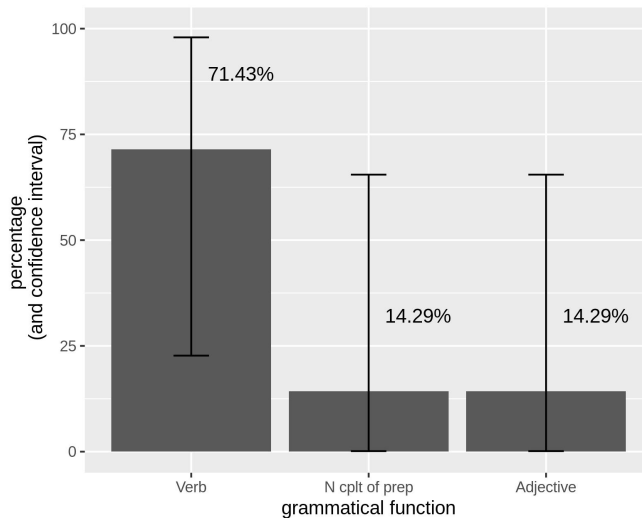

Figure 10.1: Distribution of *duquel* interrogatives in Frantext 2000–2013 (cplt = complement). See page 129 for the confidence intervals (here three comparisons).

The four *c’est*-clefts are all pied-piping cases like (10.1), where *de qui* is either the complement of a preposition or of a noun complement of a preposition. The pied-piped PP is an adjunct with respect to the verb of the relative clause. All *c’est*-clefts except (10.1) are presentational.

- (10.1) (Journal : 1928, Christian Lazard, 2012)  
 C' est le résultat du Congrès radical [à la suite *duquel*]<sub>i</sub>  
 it is the result of the congress radical at the following of the which  
 [Herriot, Sarraut, Queuille et Perrier ont démissionné <sub>-i</sub>].  
 Herriot Sarraut Queuille and Perrier have resigned  
 'It is the result of the Congress of the Radical Party following which  
 Herriot, Sarraut, Queuille and Perrier resigned.'

The following section discusses the results for the relative clauses.

### 10.1.3 Results and analysis

We excluded five relative clauses without a gap and 11 verbless relative clauses. The functions of *de qui* in the remaining 925 relative clauses with an antecedent and a verb are given in Table 10.1 and in Figure 10.2.

Table 10.1: Distribution of *duquel* relative clauses in Frantext 2000–2013

	Frequency	%
Verb	46	4.97
Noun		
Subject	7	0.76
Object	10	1.08
Predicate	2	0.22
Cplt of Preposition	567	61.30
Adjective	4	0.43
Preposition	286	30.92
Adjunct	3	0.32

*Duquel* relative clauses differ substantially from *de qui* relative clauses. More than 90% of the occurrences are pied-piped. Even when *duquel* is the *de*-complement of a subject or object noun, the whole NP is sometimes pied-piped, as illustrated in example (10.2). This phenomenon, while very common in English, is possible but stylistically marked in French. Notice that both examples are from the same author, and my subjective impression is that both relative clauses (especially 10.2a) are nearly infelicitous, unlike the relative clauses cited so far.

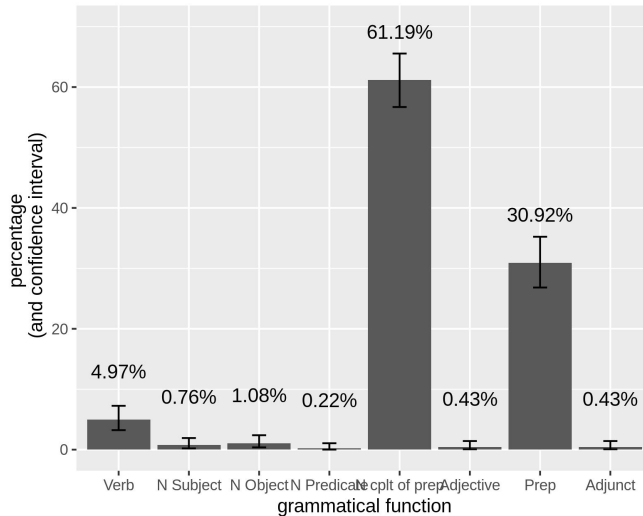

Figure 10.2: Distribution of *duquel* relative clauses in Frantext 2000–2013. See page 129 for the confidence intervals (here eight comparisons).

- (10.2) a. (La dissolution, Jacques Roubaud, 2008)  
 une publication traînante autour de mon lit où un film  
 a work lying around of my bed where a movie  
 avec cet acteur, [la tête duquel]<sub>i</sub> [–<sub>i</sub> était reproduite], que je  
 with this actor the head of.the.which was reproduced that I  
 reconnus  
 recognized  
 ‘a work lying under my bed where a film with this actor, whose  
 head was reproduced, I recognized it/him(?)’
- b. (La Bibliothèque de Warburg : version mixte, Jacques Roubaud,  
 2002)  
 j’ ai switché un moment dans la lignée temporelle, moment  
 I have switched a moment in the line timely moment  
 [la durée duquel]<sub>i</sub> [je ne peux préciser –<sub>i</sub>]  
 the duration of.the.which I NEG can specify.INF  
 ‘I switch for a moment in the timeline, a moment whose duration I  
 can’t specify.’

Extraction out of NPs is generally very rare with *de quel* + N, so a quantitative analysis is not very appropriate in this case. However, extraction out of the sub-



ject is attested, as is extraction out of the object. Extraction out of the predicate is the only kind of extraction whose frequency statistically does not differ from zero.

There are six cases of extraction out of a subject NP. Five of them are from Anne-Marie Garat, three of them involve subjects of transitive verbs, like (10.3).

- (10.3) (La Première fois, Anne-Marie Garat, 2013)  
 ce livre sans images, carte ni gravure [...], *duquel* [la  
 this book without illustration map nor engraving of.the.which the  
 reliure –] tache les doigts de moisissure et [les feuilles –] sentent  
 binding stains the fingers of mold and the pages smell  
 l' amande amère  
 the almond bitter  
 'this book without any illustration, map or engraving, whose binding  
 stains the fingers with mold and whose pages smell like bitter almond'

The last one is a long-distance dependency with extraction out of the subject of an embedded question. Hence, it is a violation of two alleged islands: subject island and *wh*-island.

- (10.4) (Mécanique, François Bon, 2001)  
 l' ordinateur de plastique tout neuf, *duquel<sub>i</sub>* il vous avait  
 the computer of plastic all new of.the.which he you.DAT had  
 demandé [à quoi servaient [les prises de branchement –<sub>i</sub>, là ,sur  
 asked at what are.used the plugs of connection there on  
 le côté]]  
 the side  
 'the brand-new plastic computer, of which he had asked you what the  
 connection plugs there on the side were good for'

The corpus also includes other cases of extraction out of the subject, even though this is not directly reflected by Table 10.1 and Figure 10.2. Example (10.5) is extraction out of a subject, albeit *duquel* itself is not a complement of the subject noun (it is annotated as complement of a noun complement of a preposition).

- (10.5) (Programme sensible, Anne-Marie Garat, 2012)  
 la poubelle du verre usagé, [au sujet de laquelle]<sub>i</sub> circula  
 the trash of.the glass used at.the subject of the.which circulates

[une pétition  $-_i$  de riverains ulcérés]  
 a petition of residents upset  
 ‘the glass recycle bin, about which a petition of upset residents  
 circulated’

Notice, however, that *au sujet de laquelle* in (10.5) could also potentially be analyzed as an adjunct:

- (10.6) Une pétition de riverains ulcérés circule [au sujet de  
 a petition of residents upset circulates at.the subject of.the  
 la poubelle de verre usagé].  
 trash of the glass used  
 ‘A petition of upset residents circulated about the glass recycle bin.’

The same does not hold for example (10.7), an extraction out of a infinitival subject (*duquel* is annotated as complement of a preposition).

- (10.7) (Pense à demain, Anne-Marie Garat, 2010)  
 une vieillese tissée de filaments du passé [au-devant  
 an old.age woven of filament of.the past toward  
 duquel]<sub>i</sub> [revenir  $-_i$ ] fatigue.  
 of.the.which come.back.INF tires  
 ‘An old age woven with filament from the past back to which to go is  
 tiring’ (intended: It is tiring to go back to the past.)

### 10.1.3.1 Subject position

Figure 10.3 shows the proportion of postverbal subjects in the *duquel* relative clauses. The distribution is similar to that for *de qui*: Postverbal subject are frequent when *duquel* is a verb complement or in pied-piping structures, and there are some cases of extraction out of an inverted subject (even though the inversion increases the distance between the filler and the gap).

### 10.1.3.2 Other factors

As already mentioned, the numebr of extractions out of the subject (and of anything else than pied-piping in general) is too low to allow any meaningful comparison. It is, for example, not possible to compare the different verb types, but extraction out of the subject of transitive verbs is attested, cf. example (10.3).

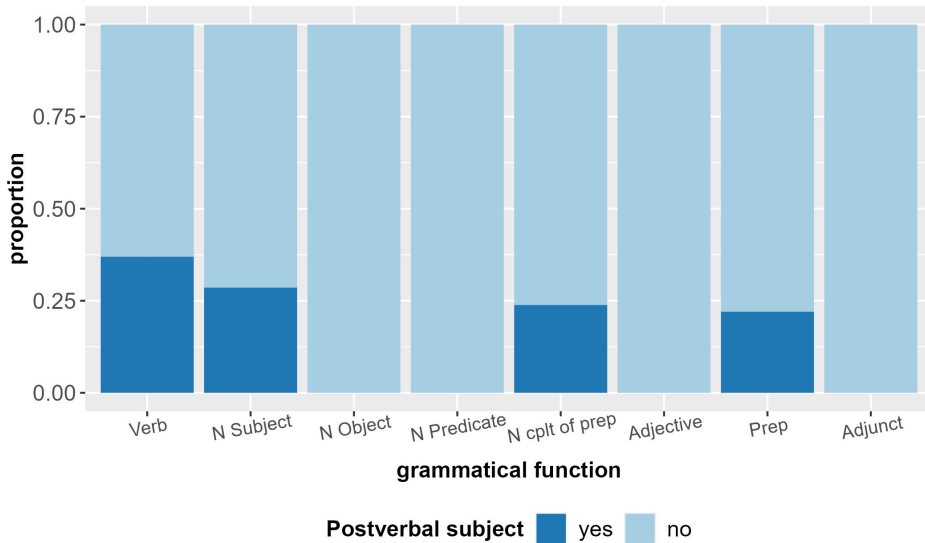

Figure 10.3: Proportion of subject-verb inversion in *duquel* relative clauses

Further annotation of number, definiteness and restrictiveness shows that most of the cases of extraction out of the subject are non-restrictive. The same holds for extraction of the complement of the verb, but not for other kinds of extraction out of NPs. The details are reported in Appendix C.

#### 10.1.4 Conclusion

The filler *duquel* is used almost exclusively for pied-piping. Just like *de qui* relative clauses, the usage for extraction out of NPs seems to be stylistically marked (it is found with a very small subset of authors), except when it occurs in pied-piping constructions.

However, extraction out of the subject is attested with statistically non-zero frequency, comparable to extraction out of the object. There is therefore no strong evidence in favor of the subject island hypothesis.

Additionally, extraction out of the subject is found with long-distance dependencies and inverted subjects. Our corpus also included one example of extraction out of an infinitival subject. Of course, one data point is not much evidence, but corpus studies are probably not ideal for investigating infinitival and sentential subjects, as they are rare. I will come back to infinitival and sentential subjects in Sections 13.1 and 13.2 in two experimental studies.

Thus the results of the corpus study on relative clauses with *de qui* tell us more about extraction out of subjects than the present study, but *duquel* relative clauses do not contradict the previous findings.

## 10.2 *Avec* + *wh*- in Frantext

### 10.2.1 Motivation

All previous corpus studies in this section deal with the extraction of *de*-PPs, and especially with *de*-PP complements of subject head nouns. We showed that extraction out of subjects is attested (and frequent) in relative clauses, and not attested in questions.

However, it has been argued that the relative word in such relative clauses is not extracted out of the subject, but is instead a sort of hanging topic (Jurka 2010, Uriagereka 2011). Under such analyses, *de*-PPs are good candidates for being topics because the relation they express is imprecise and can thus be an “aboutness” relation. If this is true, then other prepositions with a more specific semantic content should not show the same pattern as *de qui*, *duquel* or *dont* in our corpus, and be more similar to interrogatives.

For this reason, we conducted a last corpus study on *avec* (‘with’) + *wh*-. Its use should be more restricted than the previous relative and *wh*-words, because it can only be a complement to a small set of nouns. We thus expect to have fewer occurrences overall. The aim of this corpus study was to see if we find the same pattern with *avec* + *-wh* as with *de qui* (i.e. extraction out of the subject in relative clauses, with a frequency similar to that of extraction out of the object, and no extraction out of the subject in interrogatives).

### 10.2.2 Procedure

Again, the corpus Frantext 2000–2013 was used. Because a low frequency of *avec* + *wh* was expected overall, several queries were run: we looked for *avec qui* (‘with who’), for *avec quoi* (‘with what’) and for the lemmas *avec lequel* (‘with which’; and its feminine and plural derivatives *avec laquelle*, *avec lesquels* and *avec lesquelles*). In the following, the results of these three queries are combined as a single corpus study.

There were 1058 occurrences of *avec* + *wh*- in total, which were annotated as in the previous corpus studies.<sup>1</sup> We identified 930 relative clauses with an

---

<sup>1</sup>Esmá Tanis, a student assistant in the research program “Long-distance Dependencies in French: Comparative Analyses (HPSG and the Minimalist Program)”, helped with the annotation.

antecedent, five free relatives, 100 direct and indirect questions and eight *c'est*-clefts. The 15 remaining occurrences are noise, i.e. *qui* free relatives like (10.8a), and free choice uses like (10.8b).

- (10.8) a. (Qu'as-tu fait de tes frères ?, Claude Arnaud, 2010)  
 Je veux pouvoir danser jusqu' à l' aube et dormir avec  
 I want can.INF dance.INF until at the dawn and sleep.INF with  
 [qui me plaît] [...].  
 who me.ACC appeal  
 'I want to be able to dance until dawn and sleep with whom I like.'
- b. (Ceux qui savent comprendront, Anna Gavalda, 2000)  
 Je déteste me fâcher avec [qui que ce soit].  
 I hate REFL quarrel with who that it it  
 'I hate quarreling with whoever it might be.'

I will first present the results for the relative clauses, and then the results of interrogatives and *c'est*-clefts.

### 10.2.3 Results and analysis for relative clauses

We excluded two gapless relative clauses and one verbless relative clause (a fragment) from the results presented in this section. For the remaining 927 relative clauses, the distribution of *avec + wh-* is given in Table 10.2 and in Figure 10.4.

Table 10.2: Distribution of *avec + wh-* relative clauses in Frantext 2000–2013

	Frequency	%
Verb	334	36.03
Noun		
Subject	15	1.62
Object	72	7.77
Predicate	32	3.45
Adjective	20	2.16
Adjunct	454	48.98

*Avec + wh-* can thus serve as complement of a verb (10.9), of a noun (10.10) or of an adjective (10.11), or be an adjunct (10.12).

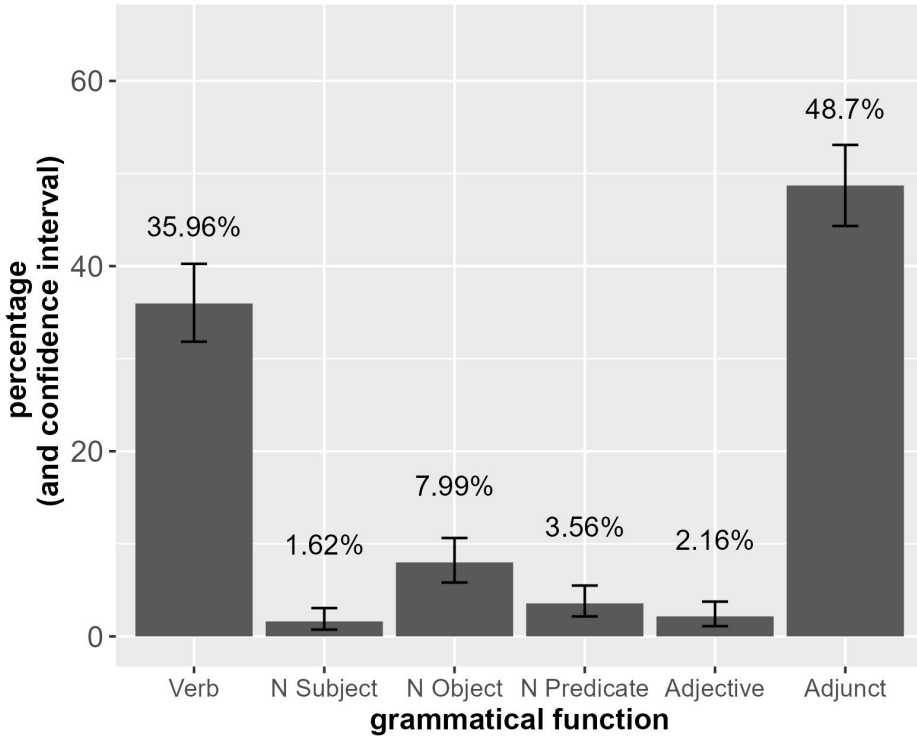

Figure 10.4: Distribution of *avec + wh-* relative clauses in Frantext 2000–2013. See page 129 for the confidence intervals (here six comparisons).

- (10.9) An example of *avec + wh-* as verb complement  
(Retour à Reims, Didier Eribon, 2009)

Le jeune homme [avec qui]<sub>i</sub> [elle avait « fauté » -<sub>i</sub>] ne devait  
 the young man with who she had sinned NEG must.PAST  
 pas être beaucoup plus âgé.  
 not be.INF much more old

‘The young man with whom she had “sinned” was probably not much older.’

- (10.10) Examples of *avec + wh-* as noun complement  
 a. Subject noun:

(L’arrivée de mon père en France, Martine Storti, 2008)  
 Pas la même chose d’avoir son beau-frère pour patron  
 not the same thing of have.INF his brother-in-law for boss

plutôt que quelqu'un [avec lequel]<sub>i</sub> [aucun lien -<sub>i</sub>] n' existe !  
 instead that someone with the.which no link NEG exists  
 '(It is) not the same thing to have your brother-in-law as a boss  
 instead of someone with whom no link exists!'

## b. Object noun:

(Impératif catégorique : récit, Jacques Roubaud, 2008)

Pourquoi ai - je choisi cette ville, [avec laquelle] je n' avais  
 why have I chosen this city with the.which I NEG had  
 [aucune attache familiale -<sub>i</sub>] ?  
 no attachment familial

'Why did I choose this city, with which I had no family  
 attachment?'

## c. Predicate:

(Ils sont votre épouvante et vous êtes leur crainte, Thierry Jonquet,  
 2006)

Tel était l' avis de Samira, [avec laquelle]<sub>i</sub> Fatoumata était  
 so was the opinion of Samira with the.which Fatouma was  
 [en total désaccord -<sub>i</sub>].  
 in complete disagreement

'This was Samira's opinion, with which Fatouma was completely  
 at odds.'

(10.11) An example of *avec + wh-* as adjective complement

(Fenêtres, Jean-Bertrand Pontalis, 2000)

Ce qui est refoulé, c' est [...] ce [avec quoi]<sub>i</sub> il est [relié -<sub>i</sub>] [...].  
 it who is repressed it is it with what he is linked

'The repressed, it's that with which he is linked.'

(10.12) Examples of *avec + wh-* as an adjunct

## a. (Tigre en papier, Olivier Rolin, 2002)

Il passait ses nuits [...] à manipuler un énorme et antique  
 he spent his nights at manipulate.INF a huge and ancient  
 poste de radio [avec lequel]<sub>i</sub> [il écoutait les ondes  
 station of radio with the.which he listened the waves  
 révolutionnaires du monde entier -<sub>i</sub>].  
 revolutionary of.the world whole

'He spent his nights manipulating a huge and ancient radio station  
 with which he listened to the revolutionary waves from the whole  
 world.'

- b. (Qu'as-tu fait de tes frères ?, Claude Arnaud, 2010)  
 Michel Dalberto, [avec qui]<sub>i</sub> [j' allais à l' école enfant -<sub>i</sub>], a  
 Michel Dalberto with who I went at the school child has  
 donné un premier récital de piano remarqué [...].  
 given a first concert of piano notable  
 'Michel Dalberto, with whom I went to school as a child, gave a  
 notable first piano concert.'
- c. (Ensemble, c'est tout, Anna Gavalda, 2004)  
 Et quand Camille s' étonnait de la rapidité [avec laquelle]<sub>i</sub>  
 and when Camille REFL wonder of the rapidity with the.which  
 [ils s' étaient engagés -<sub>i</sub>], ils la regardaient  
 they REFL were engaged they her.ACC looked  
 bizarrement.  
 weirdly  
 'And when Camille wondered about the rapidity with which they  
 got engaged, they looked at her weirdly.'

The first noticeable difference between *de*-PP and *avec*-PP is that the latter is mostly used as an adjunct. Indeed, *avec* ('with') is often used either to introduce an instrument (10.12a), a co-attendant to the event (10.12b), or an adverbial of manner (10.12c).

The second noticeable difference is that there are few extractions out of the NP: only 12.83% of the relative clauses are of this type.<sup>2</sup> We see for the first time in our corpus studies a significantly lower proportion of extractions out of a subject NP compared to extractions out of an object NP (the confidence intervals do not overlap).

The most common usage *de*-PPs extraction in relative clauses was to extract out of the subject NP. That is not the case for *avec*-PP extraction. However, the frequency of extraction out of subjects is significantly greater than zero, and not significantly lower than extraction from predicates or adjectives (which have never been claimed to be islands to extraction). Notice also, as illustrated by Figure 10.5, that in nominal subjects (i.e. subjects that allow extraction), we find more extractions out of the subject than out of the object or the predicate<sup>3</sup>.

<sup>2</sup>Anne-Marie Garat also uses few extractions out of NPs. 13.33% of the extractions out of a subject, 11.11% of the extractions out of an object and 3.12% of the extractions out of a predicate come from her work.

<sup>3</sup>All but two are cases of extraction out of a predicate and have a structure similar to (10.10c), i.e. *en* ('in') + N: *en relation* ('in relation'), *en contact* ('in contact'), *en guerre* ('in war'), etc. The two exceptions are *à l'aise* ('at ease') and *amie* ('friend').

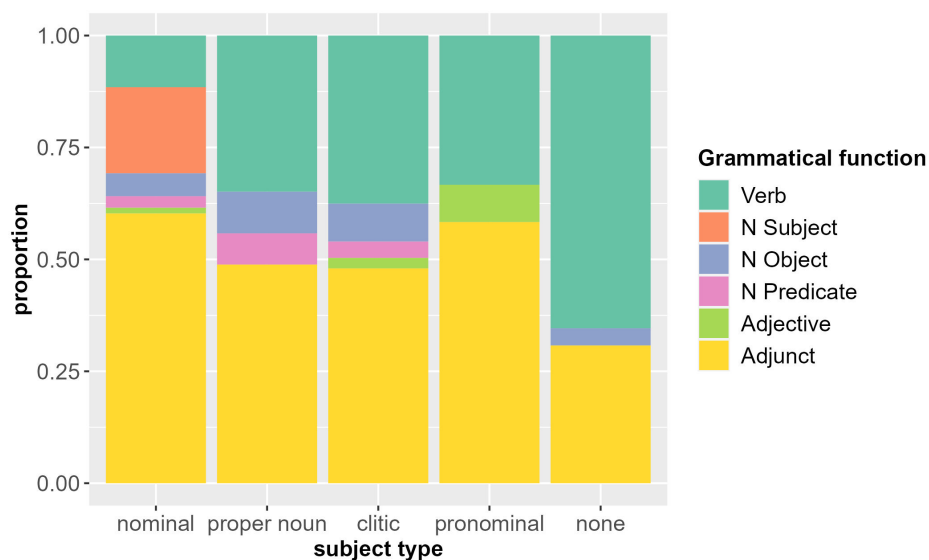

Figure 10.5: Distribution of *avec + wh-* by subject types

*Avec*-PPs are, as expected, only complement to a small subset of nouns. The ones involved in extraction out of subjects in the corpus are: *combat* ('fight'), *contact* ('contact'), *démarche* ('procedure'), *entente* ('understanding'), *lien* ('link'), *pourparlers* ('negotiations'), *rapport* ('relationship'), *relation* ('relation'), *sympathie* ('sympathy') and *vie* ('life'). Most of them also figure in extractions out of objects.

### 10.2.3.1 Subject position

Figure 10.6 shows the proportion of postverbal subjects in the *avec + wh-* relative clauses. Among the extractions out of NPs, there are only two postverbal subjects, and both are extractions out of the subject:

- (10.13) a. (L'enfant des ténèbres, Anne-Marie Garat, 2008)  
 M. Jouvét en personne [...], [avec qui]<sub>i</sub> se menaient [les  
 Mr Jouvét in person with who REFL held the  
 pourparlers <sub>-i</sub> pour adapter La Machine infernale]  
 negotiations for adapt.INF the machine infernal  
 'Mr Jouvét in person, with whom negotiations to adapt The  
 Infernal Machine were ongoing.'

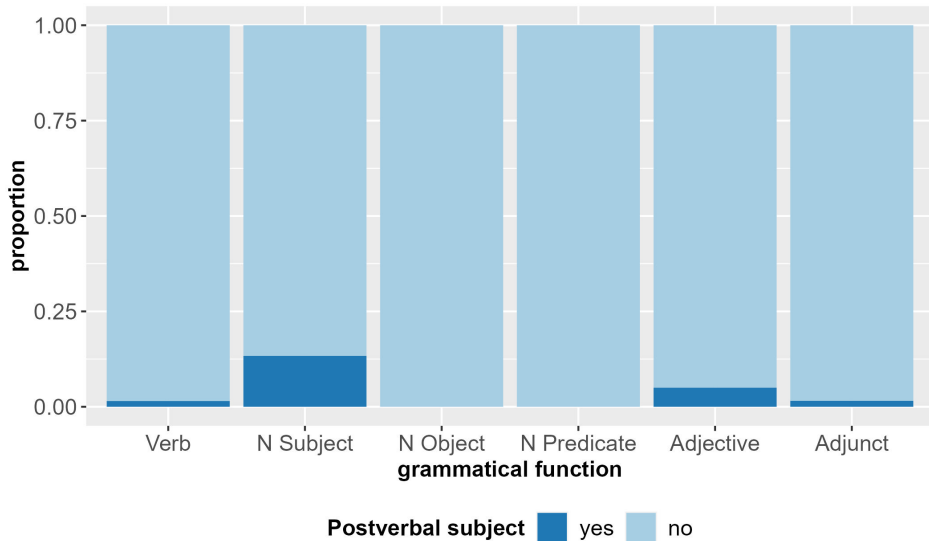

Figure 10.6: Proportion of subject-verb inversion in *avec + wh-* relative clauses

- b. (La vie sexuelle de Catherine M. précédé de Pourquoi et Comment, Catherine Millet, 2001)
- ces étrangers [avec lesquels]<sub>i</sub> – c’ est le paradoxe de la  
 these strangers with the.which it is the paradox of the  
 situation – pouvait s’ engager [une relation –<sub>i</sub> plus confiante,  
 situation could REFL initiate a relation more confident  
 plus intime, plus intense qu’ avec nos amis]  
 more intimate more intense than with our friends  
 ‘these strangers with whom – that’s the paradox of this situation –  
 a more confident, more intimate, more intense relationship could  
 be initiated than with our friends’

Notice that in example (10.13b), there is in addition a parenthetical clause between the filler and the rest of the relative clause, increasing the distance between filler and gap.

### 10.2.3.2 Verb types

The low number of hits does not allow a statistical analysis of the verb types involved in these relative clauses. We can mention, however, that there are no pas-

sives among the hits, but five mediopassives, as in (10.13), and one unaccusative. We found two transitives: one example is given in (10.14).

- (10.14) (La vie sexuelle de Catherine M. précédé de Pourquoi et Comment, Catherine Millet, 2001)  
 les personnes [avec qui]<sub>i</sub> [la relation -<sub>i</sub>] pouvait prendre un tour  
 the persons with who the relation could take.INF a turn  
 sexuel  
 sexual  
 ‘the persons with whom the relation could take on a sexual character.’

### 10.2.3.3 Other factors

Number, definiteness and restrictiveness do not seem to play an important role in distinguishing subjects from objects. Extraction out of NPs seems to be non-restrictive in a higher proportion than in the other kinds of extractions. I report more figures in Appendix C.

### 10.2.4 Results for interrogatives

There are 100 *avec* + *wh*- interrogatives in Frantext 2000–2013, 66 direct questions and 34 indirect questions. If we exclude the 53 verbless interrogatives and six *avec* + *wh*- in situ, we are left with 41 interrogatives with one gap site, 22 direct questions and 19 indirect questions.

The functions of *avec* + *wh*- in the 41 interrogatives with one gap are given in Table 10.7 and on Figure 10.3 page 279.

Table 10.3: Distribution of *avec* + *wh*- interrogatives in Frantext 2000–2013

	Frequency	%
Verb	25	60.98
Adjective	1	2.44
Adjunct	15	36.59

Only three functions are attested: the *avec*-PP is either the complement of a verb (10.15) or an adjective (10.16), or is an adjunct (10.17). Extraction out of NPs does not occur.

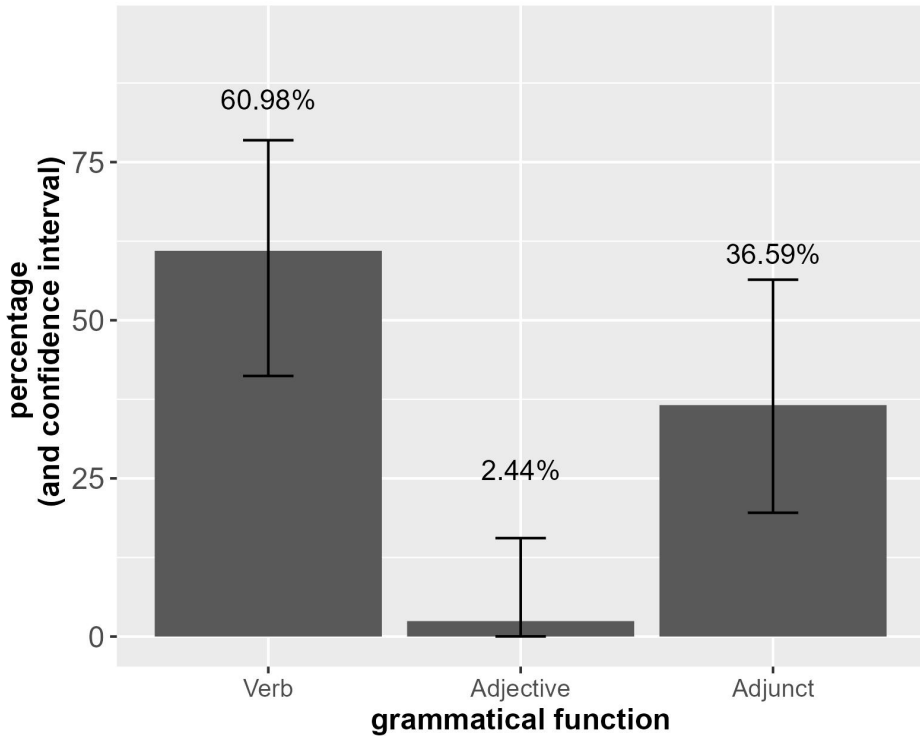

Figure 10.7: Distribution of *avec + wh-* interrogatives in Frantext 2000–2013. See page 129 for the confidence intervals (here three comparisons).

- (10.15) An example of *avec + wh-* as verb complement  
 (Un roman russe, Emmanuel Carrère, 2007)  
 [...] je ne sais pas [avec qui]<sub>i</sub> [tu es <sub>-i</sub>], mais tu n' es pas  
 I NEG know not with whom you are but you NEG are not  
 avec Véro.  
 with Véro  
 'I don't know with whom you are, but you're not with Véro.'
- (10.16) An example of *avec + wh-* as adjective complement  
 (Mécanique, François Bon, 2001)  
 [...] [avec quoi]<sub>i</sub> il ne serait pas [d'accord <sub>-i</sub>] [...] ?  
 with what he NEG would.be not in.agreement  
 'With what would he not be in agreement?'

- (10.17) An example of *avec* + *wh*- as an adjunct  
 (Les carnets blancs, Mathieu Simonet, 2010)  
 [Avec qui]<sub>i</sub> [tu fêtes Noël <sub>-i</sub>] ?  
 with who you celebrate Christmas  
 ‘With whom are you celebrating Christmas?’

### 10.2.5 Results for *c’est*-clefts

Seven out of the eight *c’est*-clefts are focalizations: the *avec*-PP is a complement of the verb (10.18a) or of the object (10.18b). The only extraction out of a subject is a presentational *c’est*-cleft (10.18c).

- (10.18) a. (Un roman russe, Emmanuel Carrère, 2007)  
 C’ est le genre d’ idée [avec quoi]<sub>i</sub> [on joue <sub>-i</sub>] [...].  
 it is the kind of idea with what one plays.  
 ‘It’s the kind of ideas with which people play.’
- b. (La vie possible de Christian Boltanski, Christian Boltanski, 2007)  
 C’ est quelqu’un [avec qui]<sub>i</sub> tu peux faire [une sorte de  
 it is someone with who you can do.INF a kind of  
 ping-pong mental <sub>-i</sub>] [...].  
 ping-pong mental  
 ‘It is someone with whom you can play some kind of mental ping-pong.’
- c. (La vie sexuelle de Catherine M. précédé de Pourquoi et Comment, Catherine Millet, 2001)  
 C’ était un homme vif et perspicace, [avec qui]<sub>i</sub> [les  
 it was a man bright and perspicacious with who the  
 conversations <sub>-i</sub>] allaient bon train [...].  
 discussions went well train  
 ‘It was a bright and perspicacious man, with whom the discussions were vivid.’

### 10.2.6 Conclusion

This corpus study demonstrates that *avec* + *wh*- is used differently in relative clauses and in interrogatives. In both, speakers use it mostly to construct adjuncts or to extract the complement of a verb, but they only extract out of NPs in relative clauses. In particular, we found no extraction out of a subject NP in interrogatives. In this respect, *avec* + *wh*- patterns with the previous corpus studies.

On the other hand, the results of this study differ from the results of those studies in that there are more occurrences of *avec* + *wh*-extracting out of object NPs than out of subject NPs in relative clauses. There is no clear indication in the corpus for the underlying reason behind this important difference between *avec*-PPs and *de*-PPs. It cannot be satisfactorily explained by syntactic accounts based on subject islands because there are still 15 felicitous cases of extraction out of subject; they are not degraded or especially odd compared to the extractions out of objects. Postulating a subject island would also fail to account for the difference across constructions.

A more promising explanation is provided by Kluender (2004), who relies on several corpus and experimental studies to show that complex subjects are dispreferred in many languages. Therefore, I propose the following: PP complements of head nouns are perceived as more complex to process when their preposition is semantically more contentful. The preposition *de* is semantically light, and thus an NP containing a *de*-PP is not perceived as complex. For this reason, extracting a *de*-PP does not cause much processing overload in addition to the processing load of the extraction itself. Thus we find the usual subject preference in extraction, i.e. extraction out of the subject is as frequent or more frequent than extraction out of the object. NPs with *avec* complements do not differ syntactically from NPs with *de* complements. However, because the preposition has more semantic content, it is perceived as more complex. The prediction then is that the more complex the NP, the less it tends to be realized as a subject. This could be tested in a corpus study with annotation of the complexity of subjects and objects (regardless of subextraction).<sup>4</sup> Such a study is beyond the scope of this work.

---

<sup>4</sup>A complexity scale could be the following: clitics < nouns without complement < nouns with a *de*-complement < nouns with another PP complement < infinitival subjects < sentential subjects.

# 11 Empirical data on questions

In this chapter, I present four experiments on interrogatives. All are acceptability judgment tasks, and are designed to replicate the previous experiments on relative clauses with similar material but for a different construction. To the best of my knowledge, no account except our proposal based on the FBC constraint expects different results across constructions. But we will see that, just like in the corpus studies, there is a sharp contrast between relative clauses and interrogatives as far as extraction out of subjects is concerned.

*Experiment 10:* In this acceptability judgment study, we crossed extraction type (extraction/non-extraction/ungrammatical controls) with syntactic function (subject/object) and tested *de quel* + N interrogatives. The extraction took place out of quality denoting NP (e.g. *originalité* ‘uniqueness’), using stimuli similar to Experiment 4. The extraction out of the subject received significantly lower ratings than the extraction out of the object, and there was a significant interaction such that ratings were lower for extraction out of the subject than for the non-extraction controls; however, they were better than for the ungrammatical controls.

*Experiment 11:* In this acceptability judgment study, we used the same materials as in Experiment 10, but the *wh*-word in the subextraction condition was in situ. We crossed question type (with *wh*-word/polar question) with syntactic function (subject/object) and tested *de quel* + N interrogatives. There was no significant difference between the conditions with the *wh*-word inside the subject NP vs. inside the object NP. There was also no significant interaction. This result is unexpected under the FBC constraint, unless in situ questions have a different information structure than questions with the *wh*-word extracted.

*Experiment 12:* In this acceptability judgment study, we crossed extraction type (extraction/non-extraction/ungrammatical controls) with syntactic function (subject/object) and tested *de qui* interrogatives. Extraction took place out of an NP denoting a social relation (e.g. *associé* ‘associate’), using stimuli similar to Experiment 7. Ratings were significantly lower for extraction

out of the subject than for extraction out of the object, and there was a significant interaction such that extraction out of the subject has lower ratings than the non-extraction controls. The results would be very similar to the results of Experiment 10 but for the very low acceptability of *de qui* subextractions: extraction out of the subject was actually not significantly better than the ungrammatical controls.

*Experiment 13:* In this acceptability judgment study, we crossed extraction type (extraction/non-extraction/ungrammatical controls) with syntactic function (subject/object) and tested *de quel* + N interrogatives in a long-distance dependency. Extraction out of the subject received lower ratings than extraction out of the object, but the difference was not significant. Overall, the results were relatively similar to the long-distance dependencies in relative clauses.

## 11.1 *De quel* in Frantext

### 11.1.1 Motivation

This corpus study is the interrogative counterpart to the study on *duquel* (Section 10.1). *Duquel* and *de quel* + N are synonymous, but whereas *duquel* is almost exclusively used in relative clauses, *de quel* can only be used in interrogatives. If the contrast between relative clauses and interrogatives found in the corpus studies on *de qui* is robust, we should find no extraction out of the subject in *de quel* interrogatives.

### 11.1.2 Procedure

Because this corpus study was intended as a counterpart to the previous one, we used the same corpus: Frantext 2000–2013. We looked for the combination of the two lemmas ‘de’ and ‘quel’, that can be realized in four forms: *de quel* (masculine singular), *de quelle* (feminine singular), *de quels* (masculine plural or masculine+feminine plural), *de quelles* (feminine plural).

This query yielded 445 occurrences of *de quel*, that we annotated as in the previous corpus studies. The results confirm that *duquel* is not used in relative clauses, and most of the time occurs in interrogatives. There were 426 direct or indirect questions and 14 exclamatives. The five remaining occurrences were noise.

There was no extraction out of the subject in exclamatives. Nine of the exclamatives were fragments, without a verb. In two of them, *de quel* + N is in situ,



like (11.1a). The three remaining ones were: one extraction of the complement of a verb (11.1b), one extraction out of an adjective and one adjunct.

- (11.1) a. (Dans la main du diable, Anne-Marie Garat, 2006)  
 Vous m' avez trahi, abusé [de quelle façon] !  
 you me.ACC have betryed abused of which manner  
 'You betrayed me, abused me in such a way!'
- b. (Journal sous l'Occupation en Périgord : 1942-1945, Jeanne Pouquet, 2006)  
 [De quelle tendresse infinie]<sub>i</sub> [mon cher mari m' a  
 of which gentleness endless my dear husband me.ACC has  
 entourée -<sub>i</sub>] !  
 surrounded  
 'With which endless gentleness did my dear husband surround me!'

The following section presents the results for the interrogatives.

### 11.1.3 Results and analysis

Of the 426 interrogatives with *de quel* + N, 259 were direct questions and 167 indirect questions. After excluding the 109 verbless interrogatives and 13 *de qui* in situ, there remain 304 interrogatives with a gap: 159 direct questions and 145 indirect questions.

The distribution of the *de quel* + N interrogatives with one gap is given in Table 11.1 and on Figure 11.1.

*De quel* + N can be the complement of a verb (11.2), of a noun (11.3), of an adjective (11.4) or of an preposition (11.5), or be an adjunct (11.6). All categories had a frequency significantly greater than zero.

- (11.2) An example of *de quel* + N as verb complement  
 (Une vie brève, Michèle Audin, 2012)  
 Je ne sais pas [de quelles « revues d' analyses »]<sub>i</sub> [disposait -<sub>i</sub> la  
 I NEG know not of which journal of analyses possessed the  
 bibliothèque de la Faculté des sciences] [...].  
 library of the Faculty of.the Sciences  
 'I don't know which analysis journal the library of the Faculty of Sciences possessed.'

## 11 Empirical data on questions

Table 11.1: Distribution of *de quel* + N interrogatives in Frantext 2000-2013

	Frequency	%
Verb	197	64.80
Noun		
Object	6	1.97
Predicate	15	4.93
Cplt of Preposition	13	4.28
Adjective	13	4.28
Preposition	4	1.32
Adjunct	56	18.42

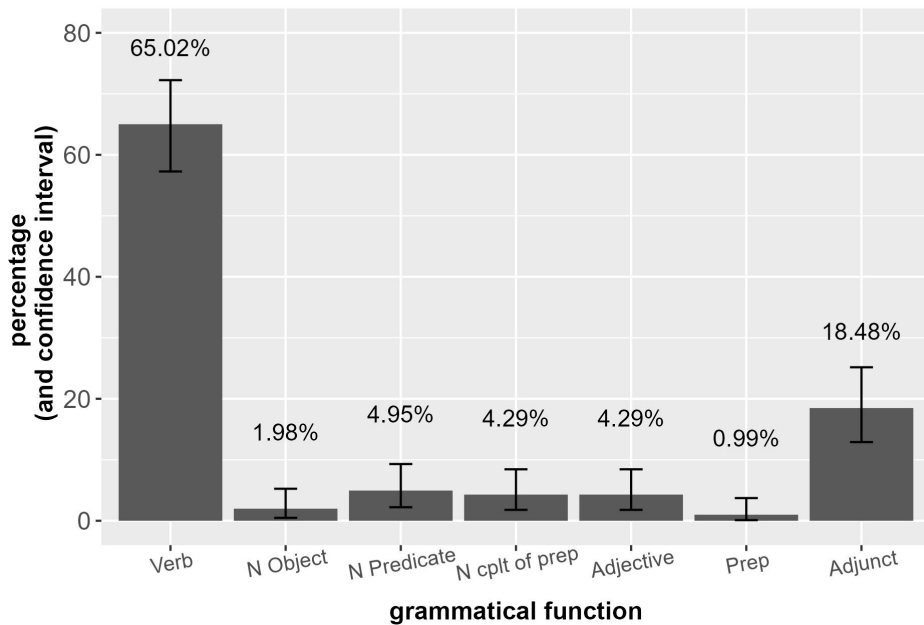

Figure 11.1: Distribution of *de quel* + N interrogatives in Frantext 2000-2013. See page 129 for the confidence intervals (here seven comparisons).

(11.3) Examples of *de quel* + N as noun complement

## a. Object noun:

(L'enfant des ténèbres, Anne-Marie Garat, 2008)

[De quelle infortune] portait - il [l' infirmité <sub>-i</sub>] [...] ?  
 of which misfortune carried he the infirmity  
 'Of which misfortune did he carry the infirmity?'

## b. Predicate noun:

(Formation, Pierre Guyotat, 2007)

[[D]e quel royaume minuscule - le plus petit d' Europe -]<sub>i</sub>  
 of which kingdom tiny the most small of Europe  
 est - il [le petit roi <sub>-i</sub>] ?  
 is he the small king  
 'Of which tiny kingdom - the smallest in Europe - is he the small king?'

## c. Noun complement of a preposition:

(La Vie sauve, Lydie Violet, 2005)

[Au terme de quelle histoire]<sub>i</sub> [a -t- il choisi cette part - là  
 at.the end of which events has <sup>0</sup> he chosen this side there  
 de l' humanité <sub>-i</sub>] ?  
 of the humanity  
 'At the end of which events did he choose this side of humanity?'

(11.4) An example of *de quel* + N as adjective complement

(Comment j'ai vidé la maison de mes parents, Lydia Flem, 2004)

[De quel impensable maternel et paternel]<sub>i</sub> étais - je [issue <sub>-i</sub>] ?  
 of which unthinkable maternal and paternal was I originating  
 'From which maternal and paternal unthinkable was I coming?'

(11.5) An example of *de quel* + N as the complement of a preposition

(Autoportrait, Édouard Levé, 2005)

Je ne sais pas [vis-à-vis de quels artistes] [j' ai des dettes <sub>-i</sub>].  
 I NEG know not toward of which artists I have some debt  
 'I don't know toward which artists I have debts.'

<sup>1</sup>In subject-verb inversion, a so-called euphonic *t* appears between the verb and the subject to avoid adjacent vowels. This euphonic *t* has no semantic content and is glossed as *0*, following the glossing guideline in Blaszczyk et al. (2007: 79).

## 11 Empirical data on questions

- (11.6) An example of *de quel* + N as an adjunct  
(Et le jour pour eux sera comme la nuit, Ariane, Bois, 2009)  
[De quel droit] lui assure -t- on que son chagrin cessera  
of which right her.DAT assures 0 one that her pain will cease  
un jour ?  
one day  
'By what right do they assure her that her pain will be over one day?'

We can see that the most common usage of *de quel* is to extract the complement of the verb, and that even pied-piping cases are relatively rare compared to *duquel* relative clauses. There are very few extractions out of an NP (6.91%, half of them being from Anne-Marie Garat).

### 11.1.4 Conclusion

If we compare *duquel* and *de quel* + N, we can see that relative clauses and interrogatives show very different patterns. This corroborates our findings for *de qui* relative clauses and interrogatives.

The dominant usage in *de qui* and *de quel* + N interrogatives is to extract the complement of the verb, and extractions out of NPs are rare. There is also no attested extraction out of the subject. In relative clauses, on the other hand, we find extractions out of NPs, and among them extractions out of subject NPs.

This cross-construction difference is only expected if we take into account the discourse status of these two constructions as in the FBC constraint.

## 11.2 Attested extractions out of the subject in interrogatives

Even though there were no case of extraction out of subjects with *de qui* and *de quel* in interrogatives in our corpus studies, it is possible to find some on the Internet. I will present here a few examples we found, will comment on them and will show how they are compatible with a discourse-based analysis.

### 11.2.1 Examples with a pre-defined set of alternatives

The following example can be found in a quiz on a website where visitors can create and take quizzes on any possible subject. Here, the subject of the quiz is the "Kids United".<sup>2</sup>

<sup>2</sup>[https://www.quizz.biz/quizz-1027073.html](https://www.quiz.biz/quizz-1027073.html), lasaccess14/03/2020

## 11.2 Attested extractions out of the subject in interrogatives

- (11.7) De qui l' anniversaire tombe -t- il le 27 ?  
of who the birthday falls 0 it the 27  
'Of who is the birthday on the 27th?'

The Kids United was a French music band consisting of five children when this quiz was released (28/12/2006). The question in (11.7) is followed by a set of possible responses: the names of the five members of the group at that time, Gabriel, Gloria, Esteban, Erza and Nilusi. Many of the previous and following questions in the quiz have the same set of possible responses since the aim of the quiz is to allow participants to test their knowledge about the members of the group: how old they are, what countries they are from, what musical instrument they can play, what are their favorite colors or superheroes, etc.

We can therefore conclude that the extracted element *de qui* ('of who') in (11.7) only superficially opens the set of alternatives from which the right answer has to be chosen, because this set of alternatives was already defined beforehand, if not by the topic of the quiz then by the previous questions. This probably makes the extraction less focalized, and as a consequence it is more felicitous.

The second example is similar in this respect. It can be found on a tutorial website<sup>3</sup> explaining how to play a game called "guess what I see":

- (11.8) Vous pourrez choisir le premier espion de différentes façons. Par  
you will.can choose the first spy of different manners for  
exemple, vous pourrez [...] demander [de qui]; [l' anniversaire-<sub>i</sub>]  
example you will.can ask.INF of who the birthday  
est le plus proche [...].  
is the most close  
'There are different ways to choose the first spy. For example, you  
can ask whose birthday is the closest.'

In this case, participants in the game must choose a first player (or first "spy"), and asking for their birthday is one method of selecting the first player. It is clear beforehand that the first player must be chosen from the players of the game. Again, the set of alternatives was known and part of the Common Ground. This could make the extraction less focalized, and thus make the discourse clash less pronounced.

---

<sup>3</sup><https://fr.wikihow.com/jouer-%C3%A0-%C2%AB-devine-ce-que-je-vois-%C2%BB>, last access 14/03/2020

### 11.2.2 Questions with a pre-defined answer (rhetorical question)

The first example comes from a political speech given by the Iranian president Mahmoud Ahmadinejad.<sup>4</sup>

- (11.9) [De quel pays]<sub>i</sub> [la dépense militaire -<sub>i</sub>] dépasse annuellement  
of which country the budget military exceeds yearly  
mille milliards de dollars [...] ?  
thousand billion of dollars  
'Of which country does the military budget exceed 100 B. dollars?'

This is obviously a translation from the original speech, and we have to bear in mind that the syntax of the sentence in the original text may have an influence on the syntax of the translation. This question follows a series of other questions very clearly targeting the USA, with explicit mentions of the nuclear bombs in Hiroshima and Nagasaki and the events of the 11th September 2001 among others. As such, the answer to the preceding series of questions has systematically been "the USA", and the hearer/reader is primed to assume the same answer to this question as well. In this case, we can even consider the extracted element *de quel pays* ('of which country') to be more of a topic continuation than focus, and the rest of the utterance can be seen as the focal domain with new pieces of information. It can be paraphrased as: *speaking of this country, its military budget exceeds 100 B. dollars*. The question is a rhetorical question, and the particular status of the extracted element can explain why extraction is felicitous and facilitated.

The second example is part of a piece of poetry from 1741, an epitaph for the "Duke of Bourbon", found on a website<sup>5</sup> that collects satirical poetry of the 18th century. I assume that Louis IV Henri de Bourbon-Condé (1692–1740) is the intended referent. The author of the poem is unknown.

- (11.10) Au fond de ce noir monument  
at.the depth of this black memorial  
Sais - tu [de qui]<sub>i</sub> [le corps -<sub>i</sub>] repose ?  
know you of how the body rests  
C' est d' un Condé, non pas le Grand.  
it is of a Condé NEG not the Great  
'In the depth of this memorial  
Do you know whose body rests?  
It is the one of a Condé, not the Great<sup>6</sup> one'

<sup>4</sup><https://www.voltairenet.org/article171526.html>, last access 14/03/2020

<sup>5</sup><https://satires18.univ-st-etienne.fr/texte/ci-g%C3%AEt-m-le-duc-de-prie-fr%C3%A8res-p%C3%A2ris/epitaphe-de-m-le-duc-de-bourbon>, last access 14/03/2020

<sup>6</sup>This is a reference to Louis II de Bourbon, Prince of Condé (1621–1686), also called the "Great Condé", the most famous member of the Condé family.

In this case also I consider the question to be a rhetorical one. The title “Epitaphe de M. le duc de Bourbon” already revealed who the epitaph is for and hence whose body is meant. The question is a rhetorical way for highlighting the disgrace of the Duke (he fell into disgrace and was exiled by the king at the end of his life) and hints that he may not be worthy of being known (hence also the allusion to his famous ancestor, with whom the Duke cannot compare).

### 11.2.3 Conclusion on the extractions out of subjects found on the Internet

These four examples are the only ones that I have been able to find on the Internet so far.<sup>7</sup> There is no good way to formulate a query that would systematically identify similar examples, because there would be too much noise: As shown in our corpus studies, extraction out of the subject in interrogatives is very rare.

In all of the examples, the alternative set opened by the focalization of the extracted element has a very particular status: it was already present in the Common Ground (and sometimes reduced to a set of one element). In fact, I am not sure that example (11.9) is a focalization at all.

We have assumed that the difficulty of extracting out of the subject in interrogatives comes from a discourse clash caused by focalizing part of a backgrounded element. Now we can explain why the attested extractions are felicitous: the element extracted in these special examples is less focal than in prototypical interrogatives, because it does not really introduce an alternative set to the Common Ground. For this reason, we have to assume that being focus is not categorical, but continuous: an element can be more or less focused, and can be more or less backgrounded. I will come back to this important point in Section 15.1.

## 11.3 Experiment 10: Acceptability judgment study on *de quel wh*-questions with *wh*-extraction

In Section 11.1, I presented a corpus study on *de quel* interrogatives. We saw that, in contrast to the corpus studies on relative clauses, we cannot find any extraction out of the subject in Frantext involving *de quel* + N. The aim of this study was to test this kind of interrogative with an experimental design.

---

<sup>7</sup>I thank Anne Abeillé who discovered examples (11.7) and (11.9).

### 11.3.1 Design and materials

To construct the stimuli for Experiment 10, we took the materials of Experiment 4 as a starting point and turned the items into interrogatives, without the long-distance dependency, which was tested in Experiment 13. For the subextraction conditions, we used *est-ce que* interrogatives (lit. ‘is it that’) because they allowed us to avoid subject-verb inversion and are natural in written and spoken language.

- (11.11) a. Condition subject + PP-extracted:  
[De quelle innovation]<sub>i</sub> est - ce que [l’ originalité <sub>-i</sub>]  
of which innovation is it that the uniqueness  
enthousiasme mes collègues sans aucune raison ?  
excites my colleagues without any reason  
‘Of which innovation does the uniqueness excite my colleagues  
for no reason?’
- b. Condition object + PP-extracted:  
[De quelle innovation]<sub>i</sub> est - ce que mes collègues admirent [l’  
of which innovation is it that my colleagues admire the  
originalité <sub>-i</sub>] sans aucune raison ?  
uniqueness without any reason  
‘Of which innovation do my colleagues admire the uniqueness  
for no reason?’

For the non-extraction conditions, we used polar questions (11.12), also constructed with *est-ce que*.

- (11.12) a. Condition subject + noextr:  
Est - ce que l’ originalité de cette innovation enthousiasme  
is it that the uniqueness of this innovation excites  
mes collègues sans aucune raison ?  
my colleagues without any reason  
‘Does the uniqueness of this innovation excite my colleagues for  
no reason?’
- b. Condition object + noextr:  
Est - ce que mes collègues admirent l’ originalité de cette  
is it that my colleagues admire the uniqueness of this  
innovation sans aucune raison ?  
innovation without any reason  
‘Do my colleagues admire the uniqueness of this innovation for  
no reason?’



For the ungrammatical controls we modified the subextraction conditions by leaving out the preposition of the extracted element.

- (11.13) a. Condition subject + ungramm:  
 [Quelle innovation]<sub>i</sub> est - ce que [l' originalité -<sub>i</sub>] enthousiasme  
 which innovation is it that the uniqueness excites  
 mes collègues sans aucune raison ?  
 my colleagues without any reason  
 'Which innovation does the uniqueness excite my colleagues for  
 no reason?'
- b. Condition object + ungramm:  
 [Quelle innovation]<sub>i</sub> est - ce que mes collègues admirent [l'  
 which innovation is it that my colleagues admire the  
 originalité -<sub>i</sub>] sans aucune raison ?  
 uniqueness without any reason  
 'Which innovation do my colleagues admire the uniqueness for  
 no reason?'

The items were very similar to the ones used in Experiment 4: the relation between *de quel* + N and the gap always expressed a quality (e.g. *originalité* 'uniqueness', *beauté* 'beauty'), and extraction always took place out of an NP headed by an inanimate noun. We used pairs of psych verbs (e.g. *apprécier* 'value' and *émerveiller* 'delight'), but also some transitive non-psych verbs (e.g. *commenter* 'comment').

We tested 24 items, each manipulated according to the six conditions described above. In addition, the experiment included 32 distractors, also interrogatives. Each experimental item and distractor was followed by a comprehension question. The comprehension questions did not have the form of an interrogative, in order to distinguish them from the sentences to be rated. Instead, they were statements, and participants were asked to respond by clicking on *Oui* ('Yes') or *Non* ('No'). The sample item presented above was followed by the comprehension question *Les collègues ont raison d'être enthousiastes*. ('The colleagues are right to be enthusiastic.'). Accuracy was very high in all conditions, indicating that participants understood the task.

### 11.3.2 Predictions

The predictions are summarized in Table 11.2. Because the design was very similar to the experiments we presented on relative clauses, and because only the

## 11 Empirical data on questions

FBC constraint predicts a cross-construction difference for extractions, all other accounts make the same predictions for this study (and for all following acceptability judgment studies on interrogatives) as they did for relative clauses.

As the questions in this experiment are presented in isolation, without any specific context, participants should treat the subject as the topic of the utterance. This leads to a violation of the FBC constraint, because questions, unlike relative clauses, focalize the the extracted element. We should then see a superadditivity effect disfavoring extraction out of the subject: extraction out of the subject (11.11a) should be degraded compared to extraction out of the object (11.11b), and should also have lower ratings than the non-extraction controls (11.12), leading to an interaction effect. However, a violation of the FBC constraint should not lead to ungrammaticality, thus extraction out of the subject (11.11a) should still be rated higher than the ungrammatical controls (11.13a). To summarize, the account based on the FBC constraint makes similar predictions as Kluender (2004) or Goldberg (2006) as far as *wh*-questions are concerned.

### 11.3.3 Procedure

We conducted the experiment on the Ixet platform (Drummond 2010). The procedure was similar to the procedure used in the previous acceptability judgment experiments (see Section 8.2.3). Participants rated the sentences on a Likert scale from 1 to 10, 1 being labeled as “bad” and 10 being labeled as “good”. They also answered comprehension questions after each sentence.

The experiment took approximately 20 minutes to complete.

### 11.3.4 Participants

The study was run in October 2017. Participants were recruited on the R.I.S.C. website (<http://experiences.risc.cnrs.fr/>) and on social media (e.g. Facebook). They received no financial compensation.

55 participants took part in the experiment. The analysis presented here is based on the data from the 47 participants who satisfied all criteria.<sup>8</sup> The 47 participants were aged 18 to 76 years. 34 of them self-identified as women, 13 self-identified as men. Six participants (12.77%) indicated having an educational background related to language.

---

<sup>8</sup>To calculate accuracy, we excluded not only the answers to comprehension questions of the practice items and of the ungrammatical controls, but also of some distractors that had a low accuracy rate.

Table 11.2: Predictions of the different accounts for Experiments 10, 12 and 13 (interrogatives with extraction). *Notes:* (a) Condition subject + PP-extracted (b) Condition object + PP-extracted (c) Condition subject + no extraction (d) Condition object + no extraction (e) Condition subject + ungrammatical (f) Condition object + ungrammatical.

		Predictions		
		“subject island” accounts	no-island accounts	
	“traditional” syntactic account	processing account with surprisal due to subject complexity	BCI account (Goldberg 2006)	account based on linear distance (DG, DLT)
extractions out of the subject vs. extractions out of the object	(a) < (b)	(a) < (b)	(a) < (b)	(a) < (b)
extractions vs. non-extractions	main effect of extraction + interaction effect such that (a) < (b,c,d)	main effect of extraction + interaction effect such that (a) < (b,c,d)	main effect of extraction + interaction effect such that (a) < (b,c,d)	main effect of extraction + interaction effect such that (a) < (b,c,d)
extractions out of the subject vs. ungrammatical controls	(a) ≈ (e)	(a) > (e)	(a) > (e)	(a) > (e)
extractions vs. ungrammatical controls	interaction effect such that (b) > (a,e,f)	main effect of grammaticality	main effect of grammaticality	main effect of grammaticality

### 11.3.5 Results and analysis

Figure 11.2 shows the results of the acceptability judgment task. In the subextraction conditions, extraction out of the subject (11.11a) received a mean rating of 4.53, lower than extraction out of the object (11.11b), which had a mean rating of 6.39. The non-extraction conditions were rated higher, with a mean rating of 8.41 in the subject control condition (11.12a), and 7.95 in the object control condition (11.12b). The ungrammatical controls received very low acceptability ratings: 2.27 in the subject condition (11.13a), and 2.73 in the object condition (11.13b).

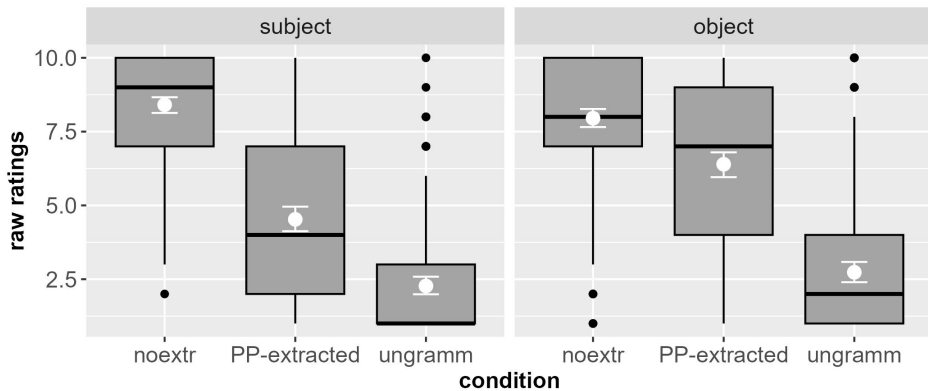

Figure 11.2: Acceptability judgments by condition in Experiment 10. The grey box plots indicate the median and quartiles of the results. Black points are outliers. Mean and confidence intervals are indicated in white.

Figure 11.2 suggests a potential ceiling effect in the non-extraction conditions and a potential floor effect in the ungrammatical controls. The ratings for the subextraction conditions, however, appear to be distributed along the whole scale. The exact distribution of the ratings is illustrated by Figure 11.3: it shows especially a floor effect in the ungrammatical subject condition. The ratings for the subextraction conditions seem to be distributed almost evenly along the scale, with a small peak at the bottom of the scale for the extractions out of subject and at the top for the extractions out of object.

Another representation of the results is given by the ROC and zROC curves in Figure 11.4. The ROC curves show that participants discriminated between the ungrammatical baselines and the other conditions. Corroborating what we see in Figure 11.2, the non-extraction conditions build larger curves than the subextraction conditions. The zROC curves are relatively straight and parallel to the baseline.

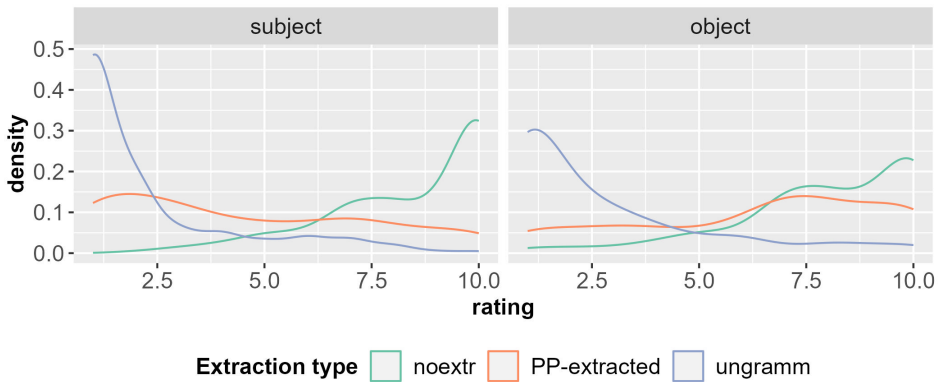

Figure 11.3: Density of the ratings across conditions for Experiment 10

The ROC and zROC curves in Figure 11.5 show the discrimination between the subject and object conditions. We see that it is in favor of the object condition for subextractions and the ungrammatical controls (the curves are above the baseline), and in favor of the subject for the controls without extraction. The zROC curves are slightly convex.

### 11.3.5.1 Habituation

The habituation effects in the course of the experiment are shown in Figure 11.6. We can see clearly that the ratings are grouped by extraction type on the graph: non-extraction at the top, subextractions in the middle, ungrammatical controls at the bottom. A discrimination between subject and object is only clear for the subextraction conditions. All conditions except the non-extraction controls undergo habituation. Despite the habituation, the extractions out of the subject never reach the acceptability ratings that the extractions out of the object display at the beginning of the experiment. They also do not seem to undergo a stronger habituation than the extractions out of the object. These facts indicate that the reduced acceptability of extractions out of the subject compared to extractions out of the object is very robust.

### 11.3.5.2 Comparing subextraction from the subject with subextraction from the object

We fitted a first model to compare the extractions out of the subject and out of the object on their own (mean centered with subject coded negative and object

## 11 Empirical data on questions

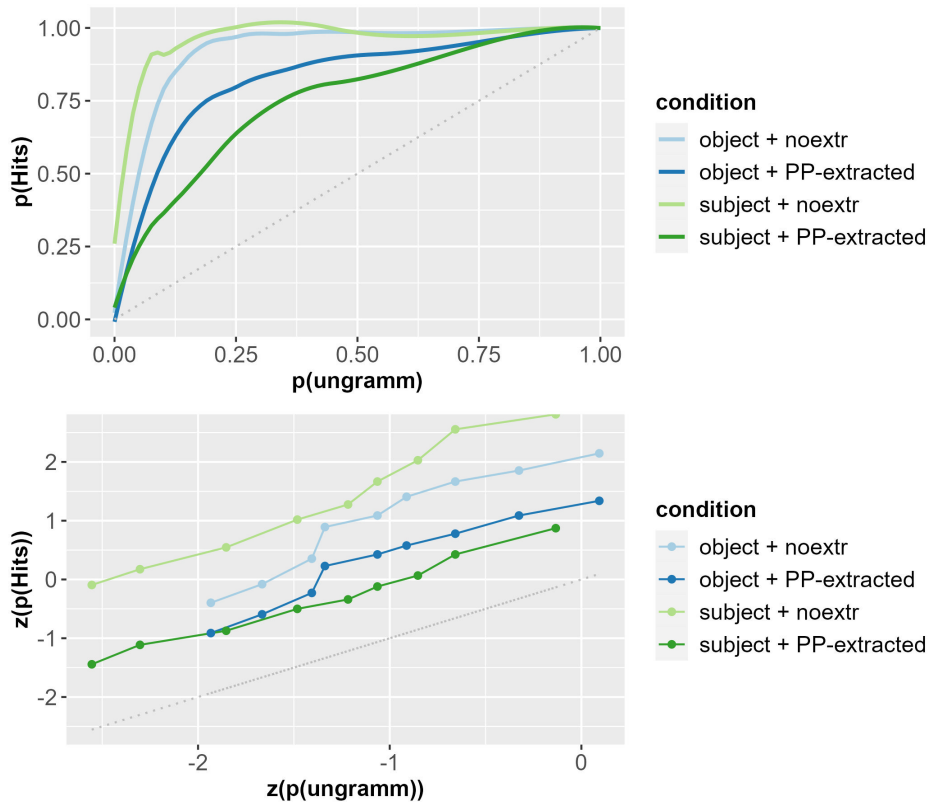

Figure 11.4: ROC curves (top) and zROC curves (bottom) of the non-extraction conditions compared to their respective subextraction condition, represented by the dotted grey baseline (Dillon & Wagers 2019’s method) in Experiment 10.

coded positive). We included trial number as a covariate, and random slopes for the fixed effects grouped by participants and items. The results of the model are reported in Table 11.3. There is a significant effect of the syntactic function, such that the object condition received significantly higher ratings than the subject condition. There is also a significant effect of trial (habituation).

In a second model, we compared the subextractions with the non-extractions. We fitted a model crossing syntactic function and extraction type (mean centered with extraction coded positive, non-extraction coded negative). We included trial number as a covariate, and random slopes for all fixed effects and covariates grouped by participants and items. The results of the model are reported in Table 11.4. There is a significant main effect of syntactic function (in favor of the

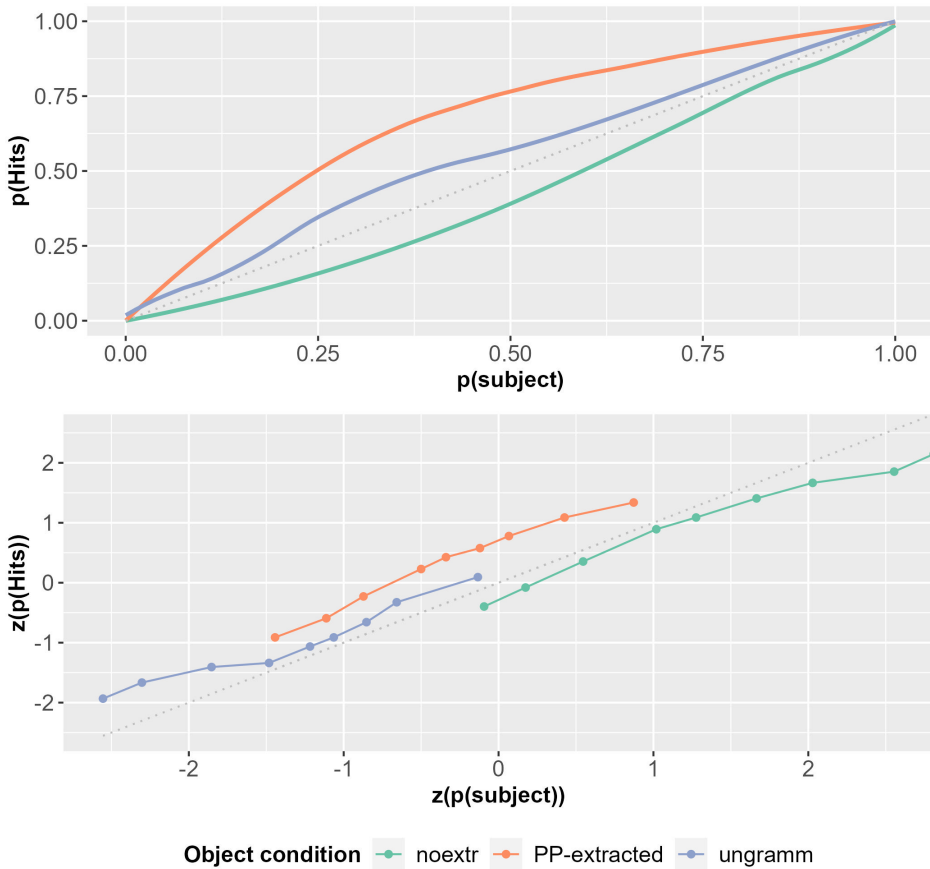

Figure 11.5: ROC curves (top) and zROC curves (bottom) of the object conditions compared to their respective subject conditions, represented by the dotted grey baseline (Dillon & Wagers 2019's method) in Experiment 10.

## 11 Empirical data on questions

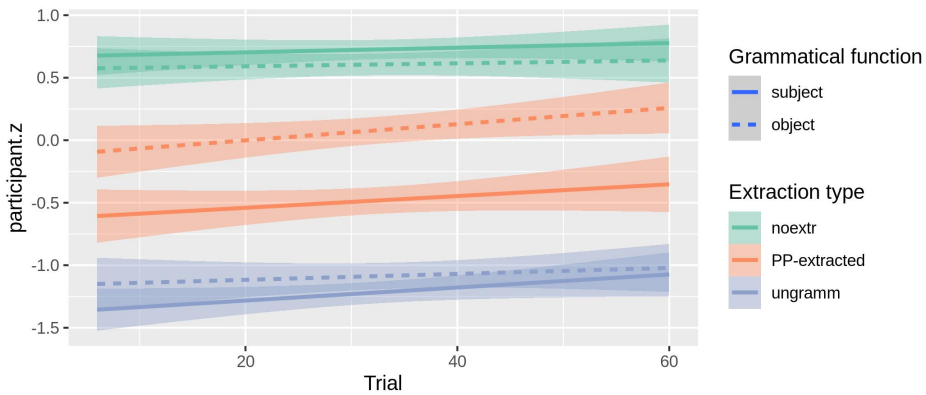

Figure 11.6: Changes in the mean acceptability ratings (z-scored by participant) by condition in the course of Experiment 10

Table 11.3: Results of the Cumulative Link Mixed Model (model n°1)

	Estimate	SE	$z$	$\Pr(>  z )$	OR
syntactic function	1.067	0.198	5	<0.001	2.91
trial	0.022	0.007	3	<0.005	1.02

object), a significant main effect of extraction type (non-extractions were rated higher), and a significant main effect of trial (habituation). There is also a significant interaction effect. Figure 11.7 indeed shows considerably lower ratings for extractions out of subjects compared to the other conditions. The difference is also significant ( $p < 0.005$ ) if we compare the the AUCs (green and red curves on Figure 11.5 on page 299).

Table 11.4: Results of the Cumulative Link Mixed Model (model n°2)

	Estimate	SE	$z$	$\Pr(>  z )$	OR
syntactic function	0.316	0.136	2	<0.05	1.37
extraction type	-1.835	0.240	-8	<0.001	6.26
trial	0.024	0.008	3	<0.005	1.02
syntactic function:extraction type	0.767	0.142	5	<0.001	2.15



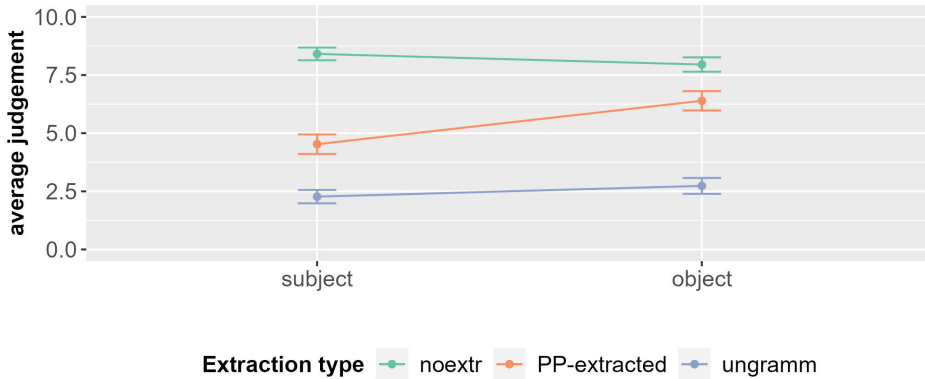

Figure 11.7: Interaction between syntactic function and extraction type in Experiment 10

### 11.3.5.3 Comparing subextraction from the subject with ungrammatical controls

A third model compared extraction out of the subject and the subject ungrammatical controls on their own (mean centered with subextraction coded positive and ungrammatical coded negative). We included trial number as a covariate, and random slopes for all fixed effects and covariates grouped by participants and items. The results of the model are reported in Table 11.5. There is a significant effect of extraction type, such that ratings for extraction out of the subject are significantly higher than for its ungrammatical control. There is also a significant effect of trial (habituation).

Table 11.5: Results of the Cumulative Link Mixed Model (model n°3)

	Estimate	SE	z	Pr(>  z )	OR
extraction type	2.342	0.395	6	<0.001	10.40
trial	0.039	0.012	3	<0.005	1.04

In a fourth model, we compared subextraction with the ungrammatical controls. We fitted a model crossing syntactic function (mean centered with object coded positive, subject coded negative) and extraction type (grammaticality). We included trial number as a covariate, and random slopes for all fixed effects grouped by participants and items. The results of the model are reported in Table 11.6. There is a significant main effect of syntactic function (in favor of the

## 11 Empirical data on questions

object), of extraction type (in favor of the extraction conditions) and of trial (habituation). There is also a significant interaction: extraction out of the object was rated higher than all other conditions.

Table 11.6: Results of the Cumulative Link Mixed Model (model n°4)

	Estimate	SE	$z$	$\Pr(>  z )$	OR
syntactic function	0.836	0.188	4	<0.001	2.31
extraction type	2.200	0.305	7	<0.001	9.02
trial	0.021	0.005	4	<0.001	1.02
syntactic function:extraction type	0.299	0.112	3	<0.01	1.35

### 11.3.6 Discussion

The results of Experiment 10 strikingly differ from the results of all previous experiments on relative clauses. When extracting out of subjects by means of a *wh*-question, we observe an “island effect”: the ratings are lower than those for extraction out of the object (model n°1), and there is a significant interaction (model n°2). The interaction is significant even in the more conservative analysis of the AUCs.

However, even though extraction out of the subject receives low ratings, it remains significantly more acceptable than the ungrammatical controls with a preposition missing (model n°3).

These results are expected under the FBC constraint. They are also compatible with processing accounts based on surprisal as well as with other discourse-based accounts, but these accounts cannot explain why we did not find similar results for the relative clauses. The traditional syntactic account is falsified by the significant difference between subextraction from the subject (11.11a) and ungrammatical controls (11.13a). If extracting out of the subject is ruled out for syntactic reasons, there is no explanation why it should be rated higher than another syntactic violation (preposition missing). Lastly, the results are completely unexpected under an account based on memory costs.

## 11.4 Experiment 11: Acceptability Judgment study on *de quel wh*-questions with the *wh*-word in situ

In general, a distinction is made between languages with *wh*-ex-situ and with *wh*-in-situ. But even languages with *wh*-ex-situ usually allow the *wh*-element to remain in situ in order to express echo questions or mirative questions.

As we have seen, French belongs to the category of *wh*-ex-situ languages, as do all Romance languages. Most Romance languages rule out the in-situ option for information seeking questions. This is not the case in French (Cheng & Rooryck 2000) or Portuguese (Ambar 2002), where the in-situ variant is acceptable, even beyond echo questions and mirative questions.

- (11.14) a. French  
 Jean a acheté quoi ?  
 Jean has bought what  
 ‘What did Jean buy?’
- b. Portuguese (Kaiser & Quaglia 2015)  
 O João comprou o quê?  
 DET João bought DET what  
 ‘What did João buy?’

Echo and mirative questions differ in French from in-situ information seeking questions in prosodic and syntactic<sup>9</sup> respect. They also differ from a pragmatic point of view, but we will come back to this point in the discussion below.

Interrogatives with in-situ *wh*-words are interesting for our central question. Syntactic accounts usually assume covert movement (in order to check a *wh*-feature): If this is the case, interrogatives with an in-situ *wh*-word should pattern just like interrogatives with extraction (like in Experiment 11). Under processing and discourse-based accounts, on the other hand, there should be no island effect without extraction. Interrogatives with an in-situ *wh*-word should therefore not show any penalty when extracting out of the subject. Finally, extraction is not a relevant factor for the FBC constraint, so the constraint should apply the same way, except if in-situ questions in French have a special information structure.

---

<sup>9</sup>Generally speaking, information seeking in-situ questions are more syntactically constrained than other in-situ questions. According to Schlonsky (2012), the *wh*-element cannot be within the scope of negation. Some authors also argue that it cannot be inside an embedded clause introduced by a non-factive verb, but the evidence seems weak. For a summary of these debates, see Kaiser & Quaglia (2015).

### 11.4.1 Design and materials

In this experiment, we adapted the materials from the previous experiment. The subextraction condition appeared without extraction, but with *de quel* + N in situ inside the subject NP and the object NP, respectively:

- (11.15) a. Condition subject + *wh* in-situ:  
[L' originalité de quelle innovation] enthousiasme mes  
the uniqueness of which innovation excites my  
collègues sans aucune raison ?  
colleagues without any reason  
'The uniqueness of which innovation excite my colleagues for no  
reason?'
- b. Condition object + *wh* in-situ:  
Mes collègues admirent [l' originalité de quelle innovation]  
my colleagues admire the uniqueness of which innovation  
sans aucune raison ?  
without any reason  
'My colleagues admire the uniqueness of which innovation for  
no reason?'

We also used the polar conditions from Experiment 10 as 'non-island' controls:

- (11.16) a. Condition subject + no-wh:  
Est - ce que l' originalité de cette innovation enthousiasme  
is it that the uniqueness of this innovation excites  
mes collègues sans aucune raison ?  
my colleagues without any reason  
'Does the uniqueness of this innovation excite my colleagues for  
no reason?'
- b. Condition object + no-wh:  
Est - ce que mes collègues admirent l' originalité de cette  
is it that my colleagues admire the uniqueness of this  
innovation sans aucune raison ?  
innovation without any reason  
'Do my colleagues admire the uniqueness of this innovation for  
no reason?'

Unlike Experiment 10, we did not include ungrammatical controls, because we thought they would make the experiment unnecessarily long.

We tested the same 24 items than in Experiment 10, each manipulated according to the four conditions I just described. In addition, the experiment included 36 distractors. They were a mixture of declaratives and interrogatives, some of them ungrammatical. Around 60% of the experimental items and distractors were followed by a comprehension question that could be answered by selecting *Oui* ('Yes') or *Non* ('No'). The comprehension questions sometimes had the form of an interrogative, and sometimes of a declarative. The sample item above did not have a corresponding comprehension question; a sentence like *La couleur de quelle fleur charme les vieilles dames durant leur promenade matinale ?* ('The color of which flower delights the old ladies during their morning walk?') was followed by the comprehension question *Les vieilles dames se promènent le matin ?* ('The old ladies go for a walk in the morning?'). Accuracy was very high in all conditions, indicating that participants correctly understood the task.

### 11.4.2 Predictions

Movement in Minimalism is usually motivated by the need for the extracted element to check a *wh*-feature high in the syntactic structure. Movement is thus necessary for interpretation purposes, and in order for the element to have its *wh*-form. Consequently, scholars like Watanabe (1992) or Bošković (1998) assume covert movement for in-situ questions: the element moves in deep structure, but its phonological realization remains in situ. Chinese has frequently been used as evidence that there is indeed covert movement: even though there is no (overt) extraction in Chinese, interrogatives seem to be subject to island constraints (Huang 1982, Cheng 1991).

Hence, such a syntactic account predicts a subject island effect in French: *wh*-words inside the subject as in (11.15a) should be degraded compared to *wh*-words inside the object (11.15b), and an interaction effect is expected, such that *wh*-words inside the subject (11.15a) are also worse than the non-extraction controls (11.16a) and (11.16b).

In this case, the FBC constraint also predicts the same results. If in-situ *wh*-words are focalization, then the FBC constraint is violated when the *wh*-word is in a subject, which is presumably backgrounded.

In Minimalism, the movement hypothesis for in-situ questions has been challenged by Comorovski (1996), Reinhart (1997) and Adli (2006), among others. According to them, there is no evidence of covert movement and thus of the necessity of feature checking.<sup>10</sup> In particular, Reinhart (1997) presents data from

<sup>10</sup>Cheng & Rooryck (2000) propose a somewhat different view, in which a *wh*-morpheme checks the *wh*-feature thus there is no need for movement of the *wh* word. See Adli (2006) for criticism of their main argument (intonation in in-situ questions) in French.

## 11 Empirical data on questions

Chinese and Korean that contradict Huang (1982) and Cheng (1991). This variant of the syntactic approach predicts null effects for this experiment. Processing accounts, or discourse-based accounts other than the FBC, make the same predictions.

In any case, a main effect of question type is expected, for independent reasons: previous studies have shown that in-situ *wh*-questions receive low ratings in French (Thiberge 2018).<sup>11</sup> This is probably a distortion effect caused by social desirability (Edwards 1957), given that in-situ *wh*-questions are usually considered to belong to non-standard colloquial French. Coveney (1996: 98) shows that prescriptive French grammars strongly stigmatize in-situ questions as colloquial speech. This question type is also associated with a lower social status. Thiberge (2018) conducted a between-subject study in which participants read an interview and gave their impression of the journalist. The only difference between the conditions was the type of question used by the journalist. The results show that the journalist was judged overall less educated and from a lower sociological background when they produced in-situ questions. They were also judged younger and less “parisian” than with an ex-situ question with subject-verb inversion.<sup>12</sup> Thiberge (2018) concludes that participants are negatively biased against in-situ questions.

### 11.4.3 Procedure

We conducted the experiment on the Ibex platform (Drummond 2010). The procedure was similar to that used in the previous acceptability judgment experiments (see Section 8.2.3). Participants rated the sentences on a Likert scale from 0 to 10, 0 being labeled as “bad” and 10 being labeled as “good”. They also answered comprehension questions after some of the sentences.

The experiment took approximately 20 minutes to complete.

### 11.4.4 Participants

The study was run between July and September 2018. Participants were recruited on the R.I.S.C. website (<http://experiences.risc.cnrs.fr/>) and on social media (e.g. Facebook). They received no financial compensation.

---

<sup>11</sup>However, Adli (2006) compares in-situ questions with ex-situ questions in French through a graded acceptability judgment task and a self-paced reading task, and finds no significant difference in either acceptability or reading times. In the acceptability judgment task, the experimental item follows a context sentence evoking a colloquial situation. This may be the reason why he does not see a contrast between question types.

<sup>12</sup>Ex-situ questions without inversion are also somewhat stigmatized.

30 participants took part in the experiment. The analysis presented here is based on the data from the 24 participants who satisfied all criteria.<sup>13</sup> They were aged 21 to 73 years. 19 of them self-identified as women, three self-identified as men. Three participants (12.50%) indicated having an educational background related to language.

### 11.4.5 Results and analysis

Figure 11.8 shows the results of the acceptability judgment study. For the *wh*-word in-situ inside the subject (11.15a), the mean rating was 6.25, slightly higher than for the *wh*-word in-situ inside the object (11.15b) with 6.09. The conditions without a *wh*-word were rated higher: the subject control condition (11.16a) had a mean acceptability rating of 8.97, the object control condition (11.16b) of 8.54.

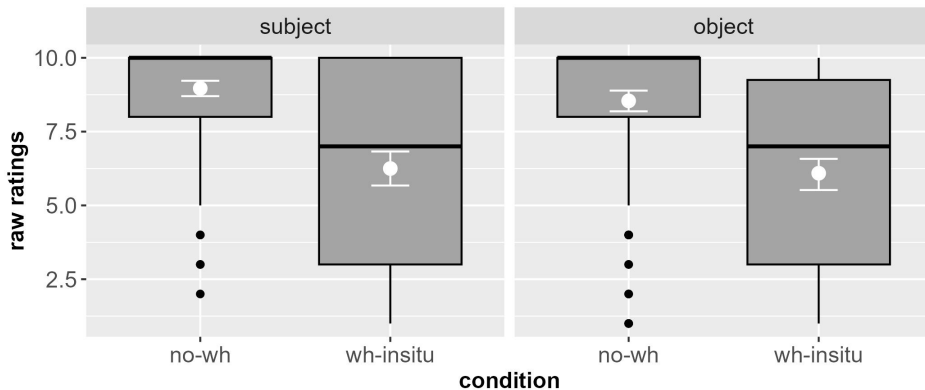

Figure 11.8: Acceptability judgments by condition in Experiment 11. The grey box plots indicate the median and quartiles of the results. Black points are outliers. Mean and confidence intervals are indicated in white.

Figure 11.8 suggests potential ceiling effects in the control conditions. This is confirmed by the distribution in Figure 11.9. The ratings for the conditions with the *wh*-word in situ seem to be distributed almost evenly along the scale, with a small peak at the top of the scale.

Another representation of the results is given by the ROC and zROC curves of the results in Figure 11.10. The ROC curves show that participants discriminated between the conditions with the *wh*-word in-situ (the baseline) and the polar

<sup>13</sup>To calculate accuracy, we excluded not only the answers to comprehension questions of the practice items and of the ungrammatical controls, but also of the ungrammatical distractors.

## 11 Empirical data on questions

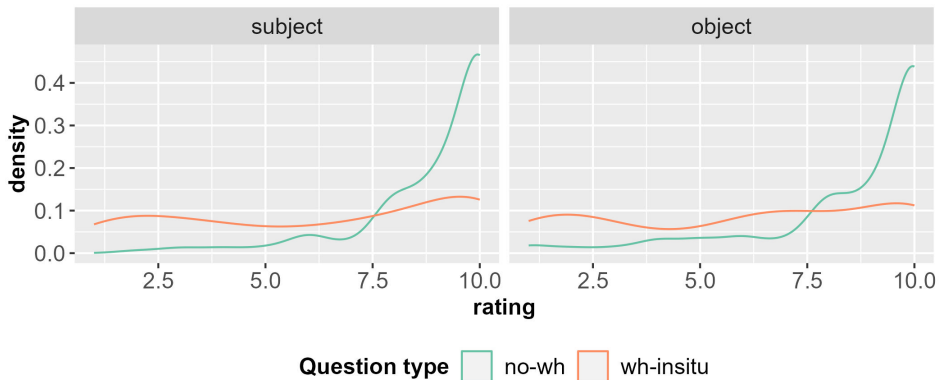

Figure 11.9: Density of the ratings across conditions for Experiment 11

questions. The object and subject curves are very close. The zROC curve for the subject condition is not parallel to the baseline, which, following Dillon & Wagers (2019), can be a sign that there is more variance in one condition. We used the function `var.text()` from the package `stats` (R Core Team 2018) for a two-by-two comparison of the variances and, indeed, there are significant differences for every condition except when we compare the two conditions with a *wh*-word in situ.

The ROC and zROC curves in Figure 11.11 show the discrimination between the subject and object conditions. We can see that participants hardly discriminate between the subject and the object variants. Again, the zROC curve for the polar question is not parallel to the baseline.

### 11.4.5.1 Habituation

Figure 11.12 on page 311 shows the habituation effects in the course of the experiment. Clearly, the ratings are grouped by question type: the polar questions are at the top, the questions with a *wh*-word at the bottom. Subject and object variants are relatively similar: the polar questions show almost no habituation effect, while there is strong habituation in the questions with a *wh*-word in-situ. At the end of the experiment, ratings for the in-situ questions were very close to the polar ones.



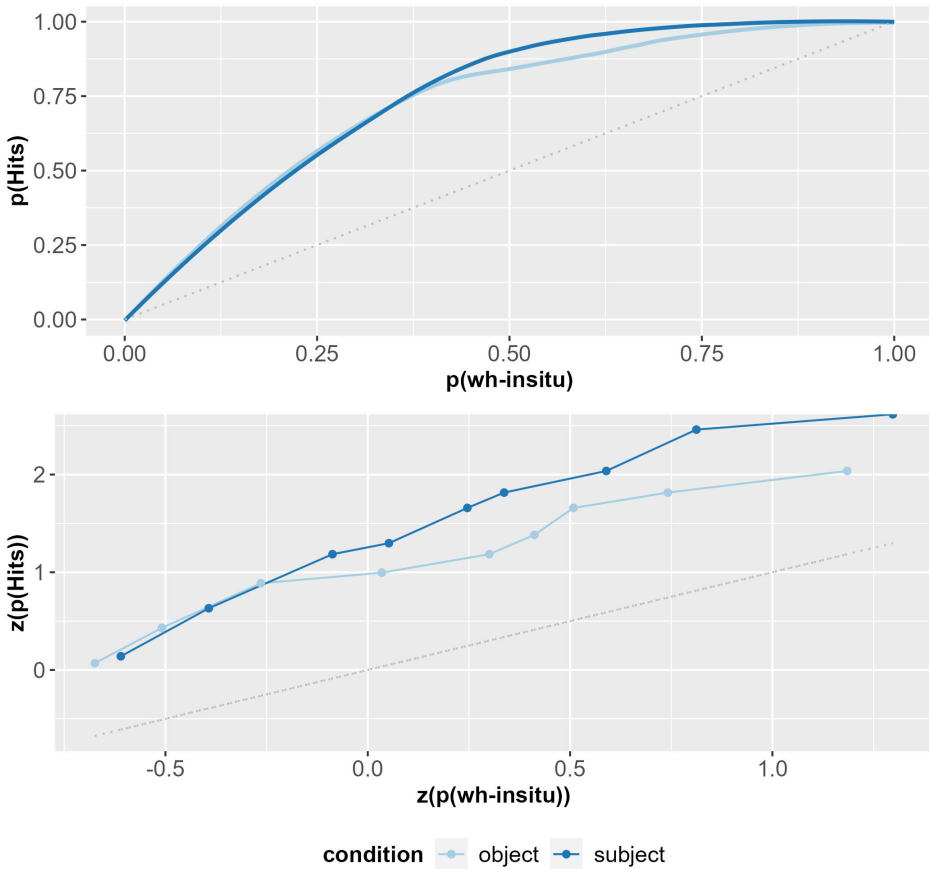

Figure 11.10: ROC curves (top) and zROC curves (bottom) of the non-extraction conditions compared to their respective subextraction conditions, represented by the dotted grey baseline (Dillon & Wagers 2019's method) in Experiment 11.

11 Empirical data on questions

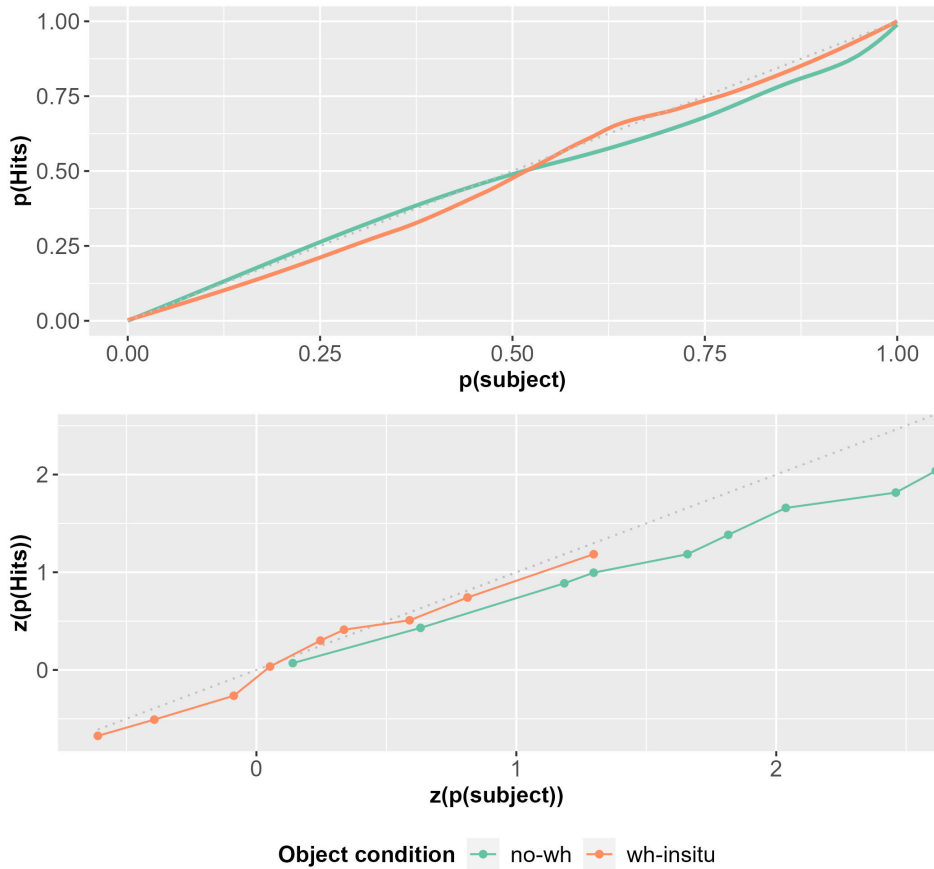

Figure 11.11: ROC curves (top) and zROC curves (bottom) of the object conditions compared to their respective subject conditions, represented by the dotted grey baseline (Dillon & Wagers 2019's method) in Experiment 11.

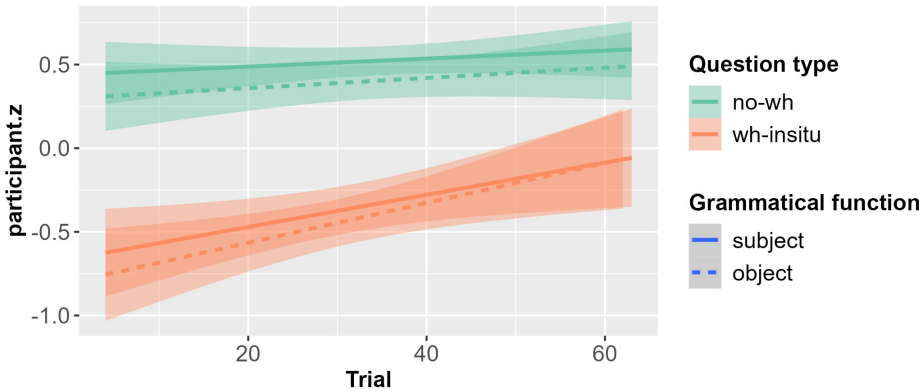

Figure 11.12: Changes in the mean acceptability ratings (z-scored by participant) by condition in the course of Experiment 11

#### 11.4.5.2 Age

Previous experiments have shown that older participants reject in-situ interrogatives more strongly than younger participants (Thiberge 2018: 72). Figure 11.13 on page 312 displays the effect of age on participants' rating (z-scored ratings) in this experiment. The results are surprising: object conditions are not affected by the factor of age, but the subject conditions are, especially when the *wh*-word is inside the subject. Older participants seem to accept in-situ *wh*-word better in subjects than in objects, and better than younger participants.

We therefore fitted a first model to predict the ratings of the questions with an in-situ *wh*-word inside the subject with trial number and age as explanatory variables. We included random slopes for trial number grouped by participants and items. The results of the model are reported in Table 11.7. There is no significant main effect of age, even though there is a significant main effect of habituation. Hence, the impression given by Figure 11.13 is not corroborated by the model.

Table 11.7: Results of the Cumulative Link Mixed Model (model n°1)

	Estimate	SE	$z$	$\Pr(>  z )$	OR
trial	0.038	0.015	3	<0.05	1.04
age	0.034	0.039	1	0.3881	1.03

## 11 Empirical data on questions

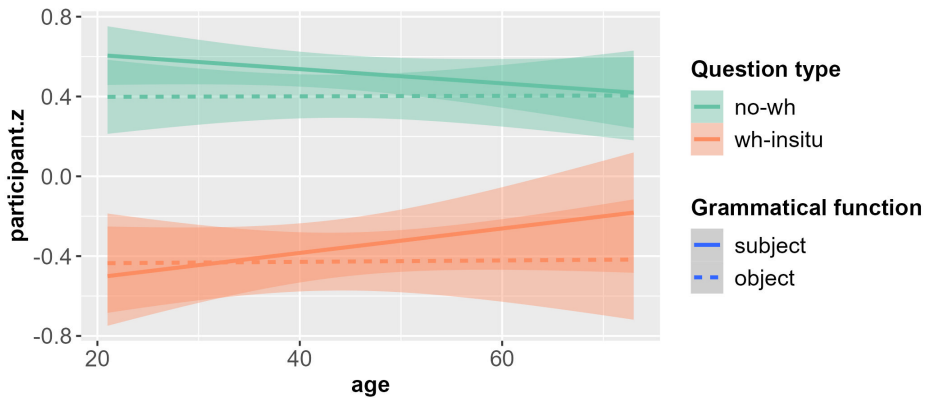

Figure 11.13: Mean acceptability ratings (z-scored by participant) by condition in Experiment 11 depending on the participants' age.

### 11.4.5.3 Comparing subject in-situ questions with object in-situ questions

We fitted a second model to compare the in-situ questions on their own (mean centered with subject coded negative, object coded positive). We included trial number and age as covariates, and random slopes for the fixed effects and trial numbers grouped by participants and items. The results of the model are reported in Table 11.8. There is a significant effect of habituation, but no significant effect of syntactic function or age.

Table 11.8: Results of the Cumulative Link Mixed Model (model n°2)

	Estimate	SE	$z$	$\text{Pr}(>  z )$	OR
syntactic function	-0.177	0.176	-1	0.3162	1.19
trial	0.031	0.012	3	<0.01	1.03
age	0.025	0.041	1	0.5308	1.03

In a third model, we compared all four conditions. The model crossed syntactic function and question type (mean centered with in-situ coded positive, no *wh*-word coded negative). We included trial number and age as covariates, and random slopes for all fixed effects and for trial number grouped by participants and items. The results of the model are reported in Table 11.9. There is a significant main effect of question type, such that the polar questions are rated significantly higher than the questions with a *wh*-word in-situ. There is also a

significant main effect of habituation, but no significant main effect of age, and no significant interaction. This is corroborated by the AUCs: if we compare the the AUCs (green and red curves on Figure 11.11), the difference is not significant. Figure 11.14 illustrates the interaction effect: the lines are parallel (no interaction).

Table 11.9: Results of the Cumulative Link Mixed Model (model n°3)

	Estimate	SE	z	Pr(>  z )	OR
syntactic function	-0.200	0.134	-1	0.1343	1.22
question type	-1.596	0.322	-5	<0.001	4.93
trial	0.027	0.010	3	<0.005	1.03
age	0.028	0.026	1	0.2842	1.03
syntactic function:question type	0.032	0.115	0	0.7828	1.03

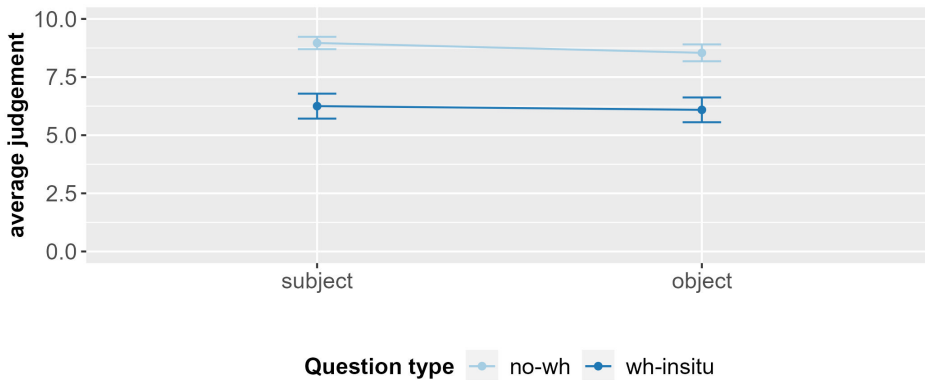

Figure 11.14: Interaction between syntactic function and extraction type in Experiment 11

### 11.4.6 Discussion

Direct interrogatives with the *wh*-word in situ received lower ratings in general than the polar controls (model n°3). This was expected given previous studies on in-situ questions in French.

However, there was no evidence for the interaction characteristic of “subject island” effects (model n°3). There was also no significant difference in ratings

between a *wh*-word inside the subject and a *wh*-word inside the object (model n°2).

The predictions of syntactic accounts that assume covert movement even with *wh*-in-situ are therefore not borne out. At the same time, the results of this study are similar to the data on Chinese and Korean presented by Reinhart (1997), in which she observes no “subject island” effect in in-situ questions.

The results also do not align with the predictions of the FBC constraint. From this, I see two possible conclusions to be drawn:

1. The current formulation of the FBC constraint is incorrect and should include the existence of a gap as a necessary condition for discourse clash. However, there is no clear a priori reason why this syntactic factor should play a role in a discourse-based constraint.
2. The FBC constraint is correct, but the above predictions were based on the – wrong – assumption that in-situ *wh*-words denote focalization. The main problem with this explanation is that it is post hoc. However, it finds support on the literature on in-situ questions.

It could also be the case that the sentences in the experiment were not interpreted as information seeking questions. We expected that reading based on our intuitions concerning the stimuli, and given the lack of context that would license a reading as an echo question or mirative question. But since the reading was not supported by either prosodic markers or context, we may have made an incorrect assumption.

I will now pursue point 2. and outline the arguments that seem to indicate that in-situ questions differ in their discursive status from ex-situ questions.

#### 11.4.7 The discursive status of in-situ questions

There is an ongoing debate in the literature about the exact pragmatic status of in-situ interrogatives in French.

Coveney (1996), Boeckx (1999), Cheng & Rooryck (2000) and Beyssade (2006) (a.o.) claim that in-situ questions are used in French whenever the proposition of the utterance is presupposed, or whenever it has been activated in the preceding discourse. However, Adli (2006) correctly underlines that in-situ questions can be used out of the blue:

- (11.17) (Adli 2006: 184)  
Pardon, il est quelle heure ?  
sorry it is which hour  
‘Sorry, what’s the time?’

Larrivée (2016) conducted several corpus searches and compared the results with corpus studies by other scholars; he comes to the conclusion that in-situ questions in French were restricted to ask for discourse-given (activated) referents from the 15th to the middle of the 19th century. During that period, in-situ questions represent less than 0.25% of the questions in written texts. From the end of the 19th century to the present, the usage of in-situ questions has increased drastically in written French, while the restriction to discourse given referents has vanished. They are still mostly used to mark orality in written texts.

We can therefore say that the debate is ongoing, and we do not have the last word yet on the pragmatic status of in-situ questions. It seems clear, however, that this status is not standard. Consequently, it is possible that the default reading is not focalization. This could explain the results (or lack of effects) in our experiment.

## 11.5 Experiment 12: Acceptability judgment study on *de qui wh*-questions with *wh*-extraction

This experiment aimed to reproduce the results of Experiment 10 (interrogatives without long-distance dependency) while being parallel to Experiment 7 (*de qui* relative clauses). The materials were based on Experiment 7, but turned into interrogatives.

### 11.5.1 Design and materials

To construct the stimuli for Experiment 10, we took the materials of Experiment 7 as a starting point and turned the items into interrogatives, following the same design as in Experiment 10. Interrogatives were formed with *est-ce que*, with polar questions as non-extraction controls, and questions with a missing preposition as ungrammatical controls.

- (11.18) a. Condition subject + PP-extracted:  
 [De qui]<sub>i</sub> est - ce que [l' associé <sub>-i</sub>] aide mon cousin sans  
 of who is it that the associate helps my cousin without  
 contrepartie financière ?  
 counterpart financial  
 'Of who does the associate help my cousin without financial  
 compensation?'

## 11 Empirical data on questions

- b. Condition object + PP-extracted:  
[De qui]<sub>i</sub> est - ce que mon cousin aide [l' associé <sub>-i</sub>] sans  
of who is it that my cousin helps the associate without  
contrepartie financière ?  
counterpart financial  
'Of who does my cousin help the associate without financial  
compensation?'
- c. Condition subject + noextr:  
Est - ce que l' associé de l' avocat aide mon cousin  
is it that the associate of the lawyer helps my cousin  
sans contrepartie financière ?  
without counterpart financial  
'Does the associate of the lawyer help my cousin without  
financial compensation?'
- d. Condition object + noextr:  
Est - ce que mon cousin aide l' associé de l' avocat  
is it that my cousin helps the associate of the lawyer  
sans contrepartie financière ?  
without counterpart financial  
'Does my cousin help the associate of the lawyer without  
financial compensation?'
- e. Condition subject + ungramm:  
Qui est - ce que l' associé aide mon cousin sans  
who is it that the associate helps my cousin without  
contrepartie financière ?  
counterpart financial  
'Who does the associate help my cousin without financial  
compensation?'
- f. Condition object + ungramm:  
Qui est - ce que mon cousin aide l' associé sans  
who is it that my cousin helps the associate without  
contrepartie financière ?  
counterpart financial  
'Who does my cousin help the associate without financial  
compensation?'

We tested the same 20 items as in Experiment 7, each manipulated according to the six conditions just described. In addition, the experiment included 36 distrac-



tors. The distractors were declaratives, and some of them were ungrammatical. Half of the experimental items and distractors were followed by a comprehension question. The item presented here as an example was paired with the comprehension question *Est-il question d'un associé ?* ('Is this about an associate?').

### 11.5.2 Predictions

The predictions for this experiment, and all experiments on interrogatives with extraction, were the same as for Experiment 10. They are summarized in Table 11.2 on page 295.

### 11.5.3 Procedure

We conducted the experiment on the Ixet platform (Drummond 2010). The procedure was similar to that in the previous acceptability judgment experiments (see Section 8.2.3). Participants rated the sentences on a Likert scale from 0 to 10, 0 being labeled as “bad” and 10 being labeled as “good”. They also answered comprehension questions after each sentence.

The experiment took approximately 20 minutes to complete.

### 11.5.4 Participants

The study was run in October 2019. Participants were recruited through Foulé-Factory (<https://www.foulefactory.com>), and paid 5€ for their participation. The payment was not contingent on the participants' responses to the questions about native language or place of birth.

57 participants took part in the experiment. The analysis presented here is based on the data from the 48 participants who satisfied all criteria.<sup>14</sup> They were aged 23 to 69 years. 36 of them self-identify as women, 12 self-identified as men. One participant (2.08%) indicated having an educational background related to language.

### 11.5.5 Results and analysis

Figure 11.15 shows the results of the acceptability judgment task. The subextraction conditions received very low rating. Extraction out of the subject (11.18a) had a mean acceptability rating of 1.49, lower than extraction out of the object (11.18b)

---

<sup>14</sup>To calculate accuracy, we excluded not only the answers to comprehension questions of the practice items and of the ungrammatical controls, but also of some distractors that had a low accuracy rate.

## 11 Empirical data on questions

with a mean rating of 2.50. The non-extraction conditions were rated high, as expected: the mean acceptability rating was 8.16 in the subject control condition (11.18c), and 7.59 in the object control condition (11.18d). The ungrammatical controls received very low acceptability ratings, comparable to the subextraction conditions: 2.03 in the subject condition (11.18e), and 1.66 in the object condition (11.18f).

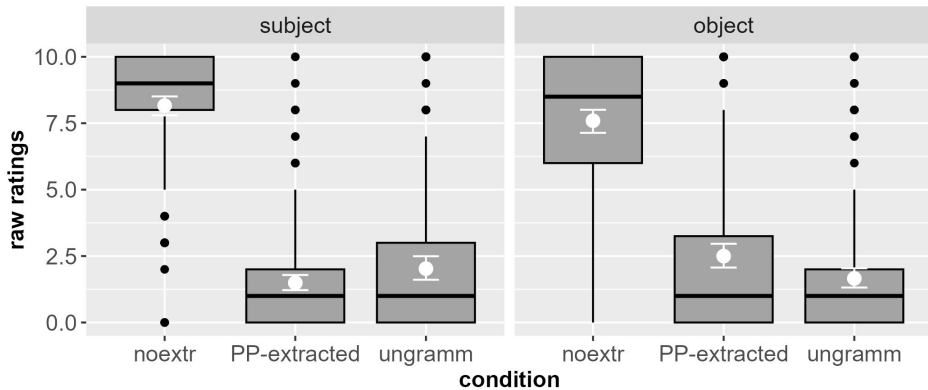

Figure 11.15: Acceptability judgments by condition in Experiment 12. The grey box plots indicate the median and quartiles of the results. Black points are outliers. Mean and confidence intervals are indicated in white.

Our conditions received either very high or very low ratings, with potential ceiling and floor effects. Figure 11.16 corroborates this: it is very probable that we see ceiling and floor effects here.

Another representation of the results is given by the ROC and zROC curves of the results in Figure 11.17 on page 320. The ROC curves show that participants discriminated between the ungrammatical baseline and the non-extraction conditions, but barely discriminated between the ungrammatical baseline and the subextraction conditions. The zROC curves are convex for the object conditions: this could be due to the strong floor effect of the ungrammatical controls that serve as a baseline.

The ROC and zROC curves in Figure 11.18 on page 321 show the discrimination between the subject and object conditions. Participant barely discriminated between the subject and the object variants, however, there is more discrimination in the subextraction conditions. The zROC curves are relatively straight, but the curve for subextraction deviates from the parallel line. This could also be due to the floor effect in the extractions out of the subject: there is much less variance because all ratings are concentrated around the bottom of the scale.

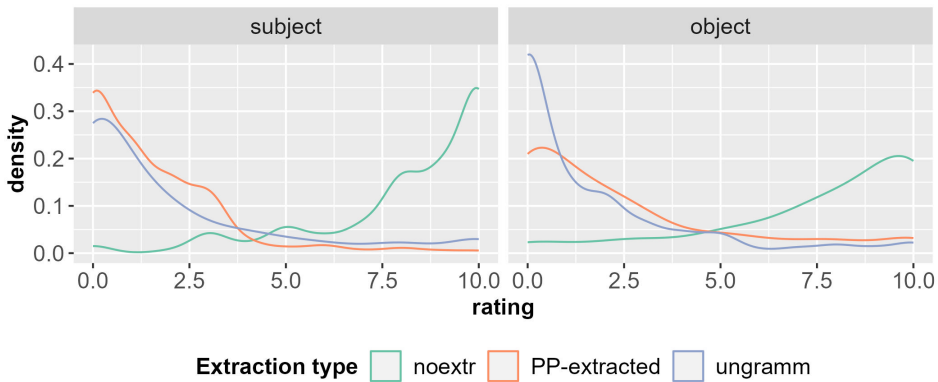

Figure 11.16: Density of the ratings across conditions for Experiment 12

### 11.5.5.1 Habituation

The habituation effects in the course of the experiment are given in Figure 11.19 on page 322. Subextraction and ungrammatical conditions are gathered at the bottom of the scale, but we can see an considerable habituation in the subextraction from object condition.

We fitted a first model to explore the habituation effect in extraction out of the object. We included random slopes for the fixed factor grouped by participants and items. The results of the model are reported in Table 11.10. The results are not significant, showing that, despite the strong habituation effect seen in Figure 11.19, the trial number is not a good predictor for the rating.

Table 11.10: Results of the Cumulative Link Mixed Model (model n°1)

	Estimate	SE	$z$	$\Pr(>  z )$	Odd.ratio
trial	0.020	0.012	2	0.0987	1.02

### 11.5.5.2 Comparing subextraction from the subject with subextraction from the object

We fitted a second model to compare the extractions out of the subject and out of the object on their own (mean centered with subject coded negative and object coded positive). We included trial number as a covariate, and random slopes for

## 11 Empirical data on questions

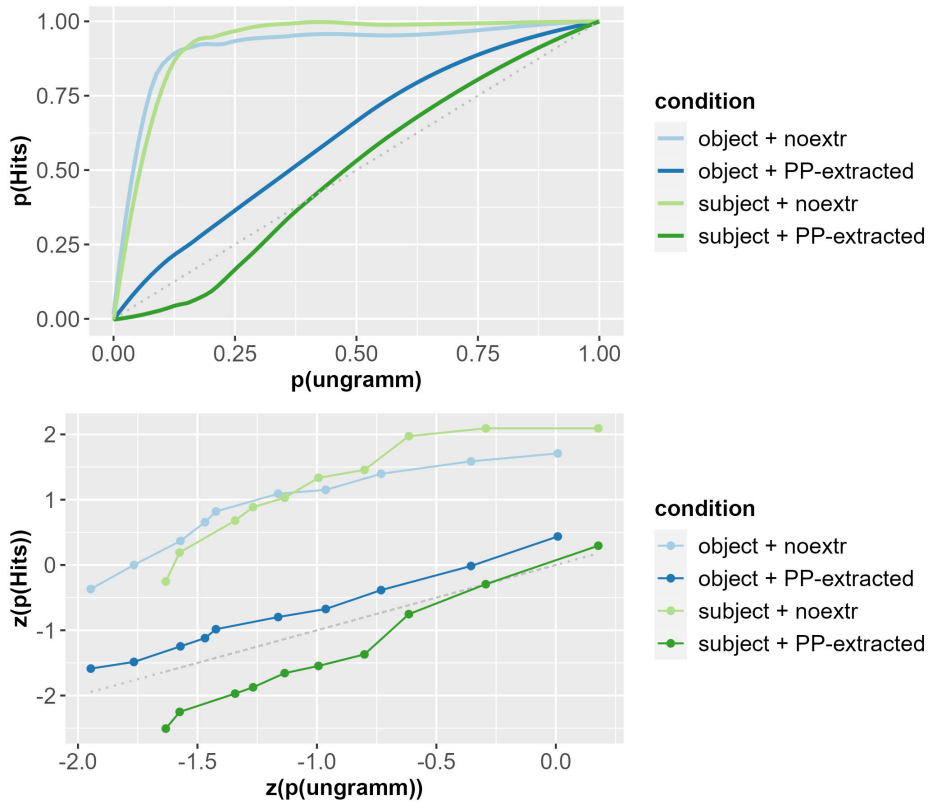

Figure 11.17: ROC curves (top) and zROC curves (bottom) of the non-extraction conditions compared to their respective subextraction conditions, represented by the dotted grey baseline (Dillon & Wagers 2019’s method) in Experiment 12.

all the fixed effects and the covariates grouped by participants and items. The results of the model are reported in Table 11.11. There is a significant effect of the syntactic function, such that the object condition has significantly higher ratings than the subject condition.

In a third model, we compared subextraction with non-extraction. We fitted a model crossing syntactic function and extraction type (mean centered with extraction coded positive, non-extraction coded negative). We included trial number as a covariate, and random slopes for all fixed effects and covariates grouped by participants and items. The results of the model are reported in Table 11.12. There is a significant main effect of extraction type (non-extractions are rated higher), and a significant main effect of trial (habituation). There is also a sig-

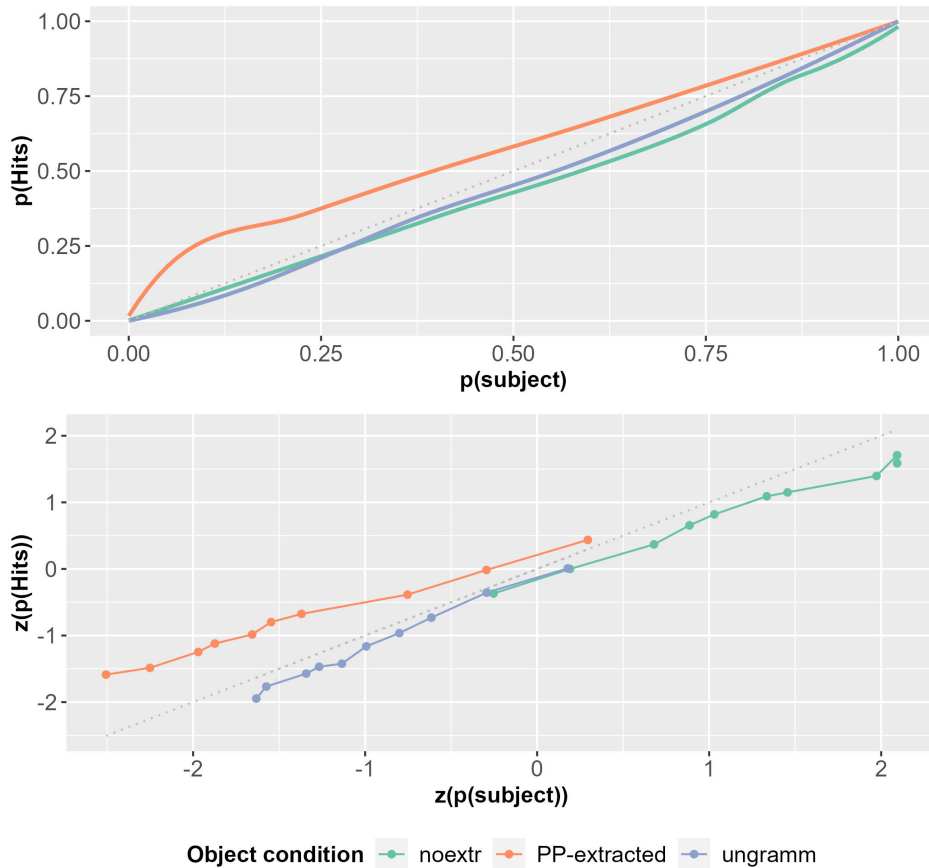

Figure 11.18: ROC curves (top) and zROC curves (bottom) of the object conditions compared to their respective subject conditions, represented by the dotted grey baseline (Dillon & Wagers 2019's method) in Experiment 12.

Table 11.11: Results of the Cumulative Link Mixed Model (model n°2)

	Estimate	SE	$z$	$\Pr(>  z )$	OR
syntactic function	0.459	0.144	3	<0.005	1.58
trial	0.016	0.010	2	0.1025	1.02

## 11 Empirical data on questions

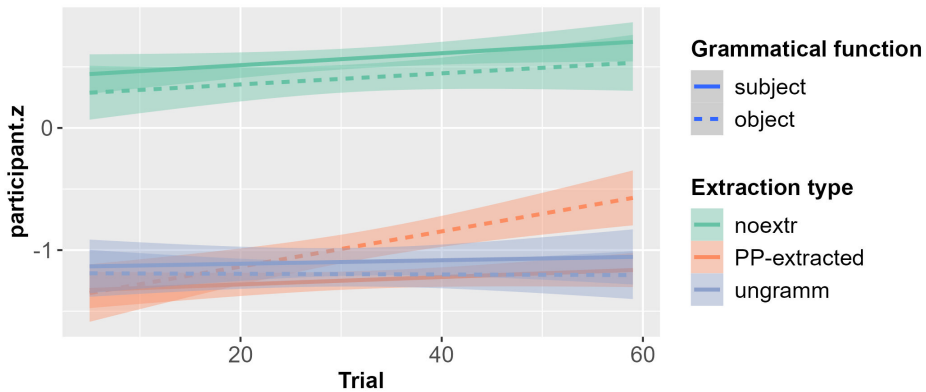

Figure 11.19: Changes in the mean acceptability ratings (z-scored by participant) by condition in the course of Experiment 12

nificant interaction effect. Indeed, Figure 11.20 shows a disadvantage for extractions out of the subject compared to the other conditions. The difference is also significant ( $p < 0.005$ ) if we compare the the AUCs (green and red curves on Figure 11.18).

Table 11.12: Results of the Cumulative Link Mixed Model (model n°3)

	Est.	SE	$z$	$\Pr(>  z )$	OR
syntactic function	0.088	0.133	1	0.5073	1.09
extraction type	-3.042	0.286	-11	<0.001	20.94
trial	0.016	0.007	2	<0.05	1.02
syntactic function:extraction type	0.411	0.132	3	<0.005	1.51

Most participants rated both subextraction conditions equally low, see Table 11.21. Participants 11, 29, 35 and 83 show a very strong preference for extraction out of the object (rated at the top of the scale). Their ratings create the advantage for extraction out of the object Only one participant, 27, has a relatively weak preference for extraction out of the subject.

We observed similar patterns in Experiment 10. Figure 11.22 on page 324 shows the results by participants for Experiment 10, and, as in Experiment 12, some of them strongly disliked subextractions from subjects while most rated them on a relatively same level of the scale, but only two participants (participants 46 and 48) showed a preference for subextractions from subjects. The conclusion is

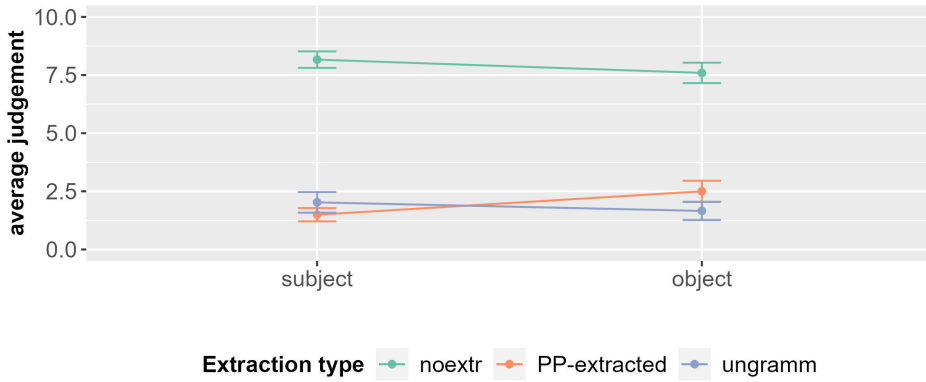

Figure 11.20: Interaction between syntactic function and extraction type in Experiment 12

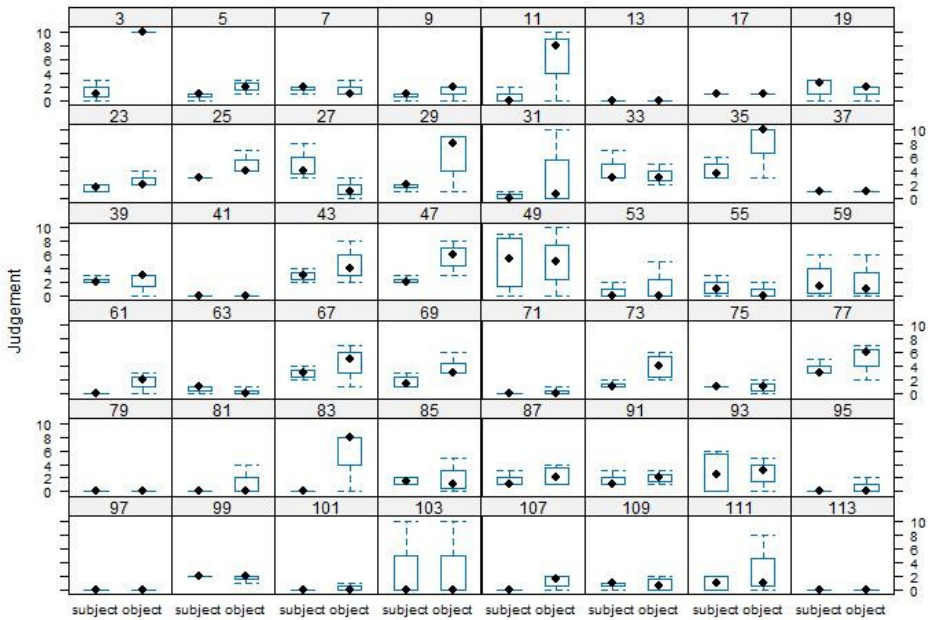

Figure 11.21: Ratings of the subextraction conditions for each participant in Experiment 12.

## 11 Empirical data on questions

that the significant interaction effect is probably due to only a few participants, but that the disadvantage of subextraction from subjects is still robust among participants, and can by no means be considered an artefact of some participants being outliers.

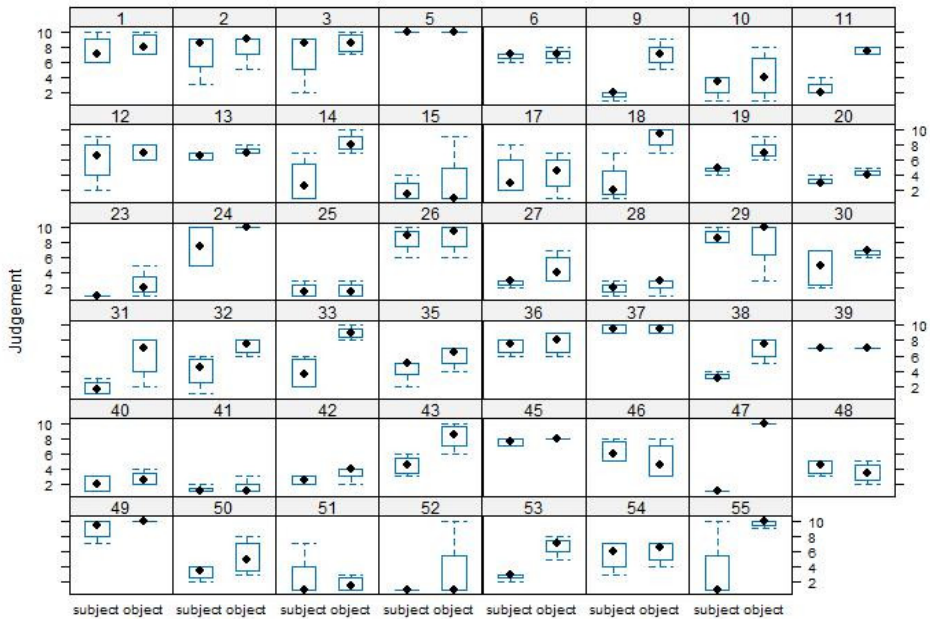

Figure 11.22: Ratings of the subextraction conditions for each participant in Experiment 10.

### 11.5.5.3 Comparing subextraction from the subject with the ungrammatical controls

We fitted a fourth model to compare the extractions out of the subject and the subject ungrammatical controls on their own (mean centered with subextraction coded positive and ungrammatical coded negative). We included trial number as a covariate, and random slopes for the fixed effect grouped by participants and items. The results of the model are reported in Table 11.13. The difference between the two conditions is not significant.



Table 11.13: Results of the Cumulative Link Mixed Model (model n°4)

	Estimate	SE	$z$	$\text{Pr}( >  z  )$	OR
extraction type	0.067	0.144	0	0.6403	1.07
trial	0.002	0.007	0	0.7865	1.00

In a fifth model, we compared the subextractions with the ungrammatical controls. We fitted a model crossing syntactic function (mean centered with object coded positive, subject coded negative) and extraction type (grammaticality). We included trial number as a covariate, and random slopes for all fixed effects grouped by participants and items. The results of the model are reported in Table 11.14. There is a significant main effect of extraction type (in favor of the extraction conditions) and of trial (habituation). There is also a significant interaction: extractions out of the object are rated higher than all other conditions.

Table 11.14: Results of the Cumulative Link Mixed Model (model n°5)

	Estimate	SE	$z$	$\text{Pr}( >  z  )$	OR
syntactic function	0.107	0.105	1	0.3112	1.11
extraction type	0.397	0.165	2	<0.05	1.49
trial	0.011	0.005	2	<0.05	1.01
syntactic function:extraction type	0.333	0.115	3	<0.005	1.40

### 11.5.6 Discussion

We see in this experiment the expected pattern of a “subject island” effect: extraction out of the subject was rated lower than extraction out of the object (model n°2) and there was a significant interaction compared to non-extraction controls (model n°3).

The low acceptability of both subextraction conditions is striking, however. Subextractions with *de quel* + N, even though degraded compared to the non-extraction conditions, were not so disfavored. Even though there was a main effect of extraction type such that subextractions received higher ratings than ungrammatical controls (model n°5), this main effect comes from subextraction from objects. The mean rating for the subextraction from the subject is actually

lower than for its ungrammatical control (model n°4) and there is no significant difference between the two. As far as model n°4 is concerned, the results are closer to the expectations under the traditional syntactic approach than to the other accounts, even though null-effects are not able to falsify the predictions of the other accounts. The significant interaction in the comparison of subextractions with ungrammatical controls (model n°5) is also only predicted by the syntactic account. However, the very low ratings for extracting out of objects with *de qui* is surprising under all accounts.

To make sense of this finding, recall the difference in acceptability between relative clauses with *dont* and with *de qui*. The subextraction conditions seemed much degraded in the *de qui* relative clauses, regardless of the syntactic function. We see a similar contrast between *de quel* and *de qui* interrogatives. The significant interaction found in model n°5 can be explained as a product of superadditivity: if it is inherently difficult to extract out of a NP with *de qui*, and this processing difficulty is compounded with difficulties discussed earlier (clash in discourse status following the FBC constraint, processing difficulty of extraction on its own, weak specificity of the pronoun), the parser may reach a point where processing the sentence is not possible anymore (at least for some parsers). Assuming that *de qui* subextractions are difficult per se is actually consistent with the results of the corpus studies. We have seen that *de qui* is not very frequent in general, that there are fewer subextractions from NP with *e qui* than with *dont* (the occurrences are overwhelmingly by one single author for 2000–2013) and that subextraction from NPs in general, and not just subextraction from subjects, is almost completely absent in interrogatives. A mere frequency effect could lead to surprisal and therefore to processing difficulties. Furthermore, this infrequency could in fact be the symptom of another reason that makes *de qui* ill-suited for subextractions.

## 11.6 Experiment 13: Acceptability judgment study on *de quel wh*-questions with long-distance dependencies

We tested *de quel* questions with a long-distance dependency. This allowed us to compare our results on the one hand with our experiment on relative clauses with a long-distance dependency (Experiment 4) and on the other hand with Sprouse et al.'s (2016) experiments on Italian and English.

### 11.6.1 Design and materials

We used as a starting point the stimuli of Experiment 10, and introduced the same long-distance dependencies as in Experiment 4. As in Experiment 10, we tested extractions out of the subject and out of the object with *est-ce que* questions. The embedding verbs were non-factive (e.g. *supposer* ‘suppose’ or *croire* ‘believe’) to make sure that the content of the embedded clause is not presupposed.

- (11.19) a. Condition subject + PP-extracted:  
 [De quelle innovation]<sub>i</sub> est - ce qu’ on suppose [que [l’  
 of which innovation is it that one supposes that the  
 originalité <sub>-i</sub>] enthousiasme mes collègues sans aucune  
 uniqueness excites my colleagues without any  
 raison] ?  
 reason  
 ‘Of which innovation do we suppose that the uniqueness excites  
 my colleagues for no reason?’
- b. Condition object + PP-extracted:  
 [De quelle innovation]<sub>i</sub> est - ce qu’ on suppose [que mes  
 of which innovation is it that one supposes that my  
 collègues admirent [l’ originalité <sub>-i</sub>] sans aucune raison] ?  
 colleagues admire the uniqueness without any reason  
 ‘Of which innovation do we suppose that my colleagues admire  
 the uniqueness for no reason?’

As in Experiment 10, we used polar questions (11.20) for the non-extraction conditions, also with *est-ce que*.

- (11.20) a. Condition subject + noextr:  
 Est - ce qu’ on suppose que l’ originalité de cette  
 is it that one supposes that the uniqueness of this  
 innovation enthousiasme mes collègues sans aucune  
 innovation excites my colleagues without any  
 raison ?  
 reason  
 ‘Do we suppose that the uniqueness of this innovation excites my  
 colleagues for no reason?’

## 11 Empirical data on questions

b. Condition object + noextr:

Est - ce qu' on suppose que mes collègues admirent l' originalité de cette innovation sans aucune raison ?  
is it that we suppose that my colleagues admire the uniqueness of this innovation without any reason  
'Do we suppose that my colleagues admire the uniqueness of this innovation for no reason?'

As in Experiment 10, the ungrammatical controls were like the subextraction conditions without the preposition of the extracted element.

(11.21) a. Condition subject + ungramm:

Quelle innovation est - ce qu' on suppose que l' originalité enthousiasme mes collègues sans aucune raison] ?  
which innovation is it that one supposes that the uniqueness excites my colleagues without any reason  
'Which innovation do we suppose that the uniqueness excites my colleagues for no reason?'

b. Condition object + ungramm:

Quelle innovation est - ce qu' on suppose que mes collègues admirent l' originalité sans aucune raison ?  
which innovation is it that one supposes that my colleagues admire the uniqueness without any reason  
'Which innovation do we suppose that my colleagues admire the uniqueness for no reason?'

We tested the same 24 items as in Experiments 4 and 10. Each item appeared in the six conditions just described. In addition, the experiment included 36 distractors. The distractors were declaratives, and some of them were ungrammatical. Half of the experimental items and distractors were followed by a comprehension question. The item presented here as an example was paired with the comprehension question *Est-ce que les collègues ont raison d'être enthousiastes ?* ('Are the colleagues right to be enthusiastic?').

### 11.6.2 Predictions

Predictions for long-distance dependencies do not differ essentially from the general predictions for interrogatives summarized in Table 11.2 on page 295.

Processing accounts expect to see more overall processing costs associated with the extraction itself because of the increased distance between the filler and the gap.

By contrast, under the discourse-based account based on the FBC constraint, extraction may be facilitated because embedded clauses may be more backgrounded.

### 11.6.3 Procedure

We conducted the experiment on the Ixona platform (Drummond 2010). The procedure was similar to that used in the previous acceptability judgment experiments (see Section 8.2.3). Participants rated the sentences on a Likert scale from 0 to 10, 0 being labeled as “bad” and 10 being labeled as “good”. They also answered comprehension questions after some of the sentences.

The experiment took approximately 20 minutes to complete.

### 11.6.4 Participants

The study was run between October and November 2019. Participants were recruited through FouleFactory (<https://www.foulefactory.com>), and paid 5€ for their participation. The payment was not contingent on the participants’ responses to the questions about native language or place of birth.

65 participants took part in the experiment. The analysis presented here is based on the data from the 51 participants who satisfied all criteria.<sup>15</sup> They were aged 21 to 78 years. 31 of them self-identified as women, 20 self-identified as men. Two participants (3.92%) indicated having an educational background related to language.

### 11.6.5 Results and analysis

Figure 11.23 shows the results of the acceptability judgment task. In the subextraction conditions, the extraction out of the subject (11.19a) had a mean rating of 3.07, lower than extraction out of the object (11.19b) with a mean rating of 3.39. The difference between the two conditions is not as manifest as in Experiment 10 (without the long-distance dependency). The non-extraction conditions were rated higher than the subextraction conditions: the subject control condition (11.20a) had a mean rating of 6.25, the object control condition (11.20b) of

---

<sup>15</sup>To calculate accuracy, we excluded not only the answers to comprehension questions of the practice items and of the ungrammatical controls, but also of the ungrammatical distractors.

## 11 Empirical data on questions

6.09. The ungrammatical controls received very low ratings: 1.99 in the subject condition (11.21a), and 2.35 in the object condition (11.21b).

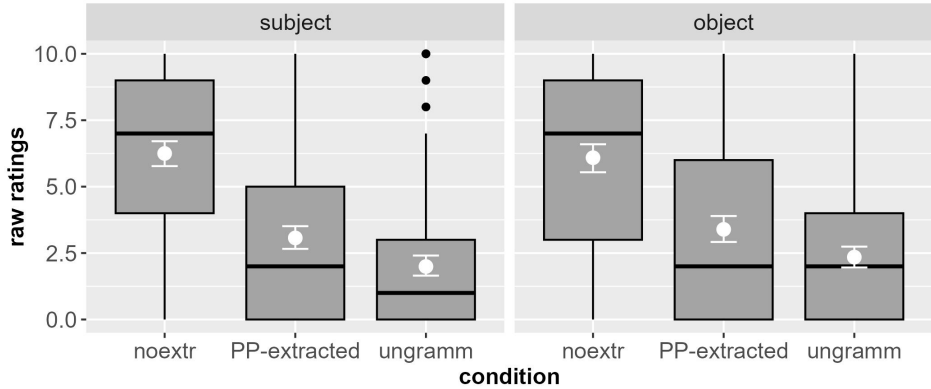

Figure 11.23: Acceptability judgments by condition in Experiment 13. The grey box plots indicate the median and quartiles of the results. Black points are outliers. Mean and confidence intervals are indicated in white.

Figure 11.23 suggests potential floor effects in the ungrammatical controls. Figure 11.24 confirms this impression: The ungrammatical controls display a floor effect, especially in the subject variant, but the other conditions seem to have a normal distribution.

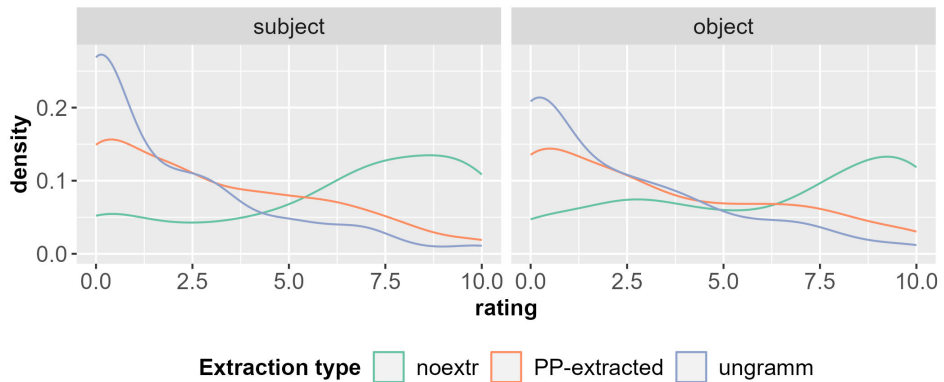

Figure 11.24: Density of the ratings across conditions for Experiment 13

Another representation of the results is given by the ROC and zROC curves of the results in Figure 11.25 on page 331. The ROC curves show that participants discriminated between ungrammatical baselines and the other conditions.

As expected based on the data in Figure 11.23, the non-extraction conditions build larger curves than the subextraction conditions. The zROC curves are relatively straight and parallel to the baseline.

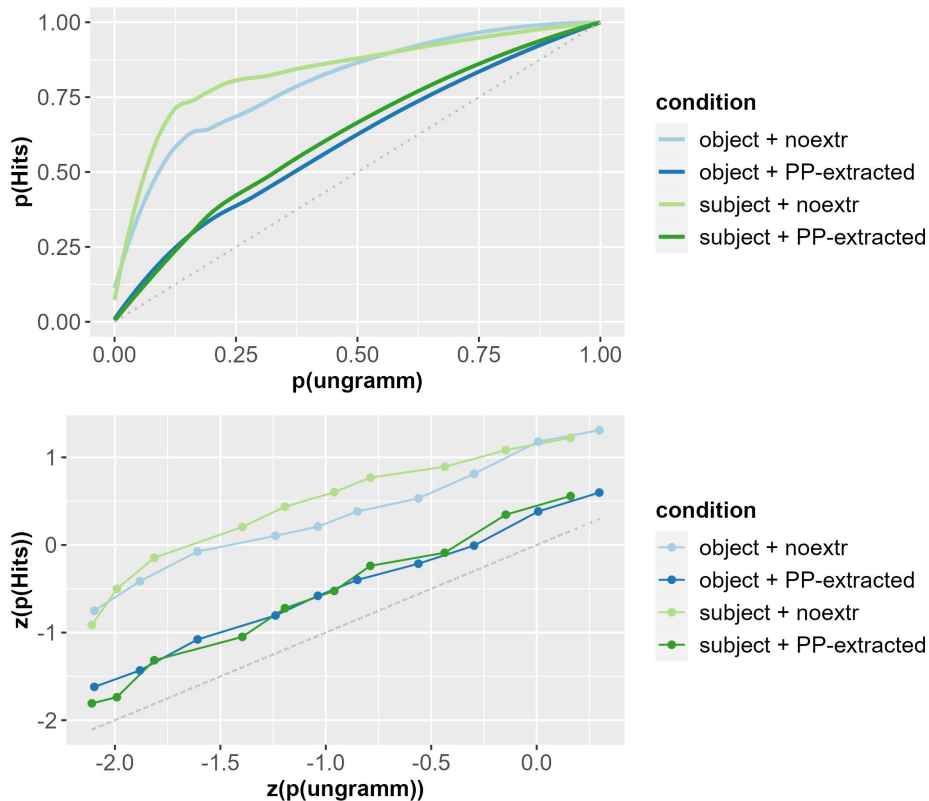

Figure 11.25: ROC curves (top) and zROC curves (bottom) of the non-extraction conditions compared to their respective subextraction conditions, represented by the dotted grey baseline (Dillon & Wagers 2019's method) in Experiment 13.

The ROC and zROC curves in Figure 11.26 on page 332 show the discrimination between the subject and object conditions. We see that participants barely discriminated between the two. The zROC curves are relatively straight and parallel to the baseline.

### 11.6.5.1 Habituation

The habituation effects in the course of the experiment are given in Figure 11.27 on page 333. The subextraction conditions and the ungrammatical controls show strong habituation.

11 Empirical data on questions

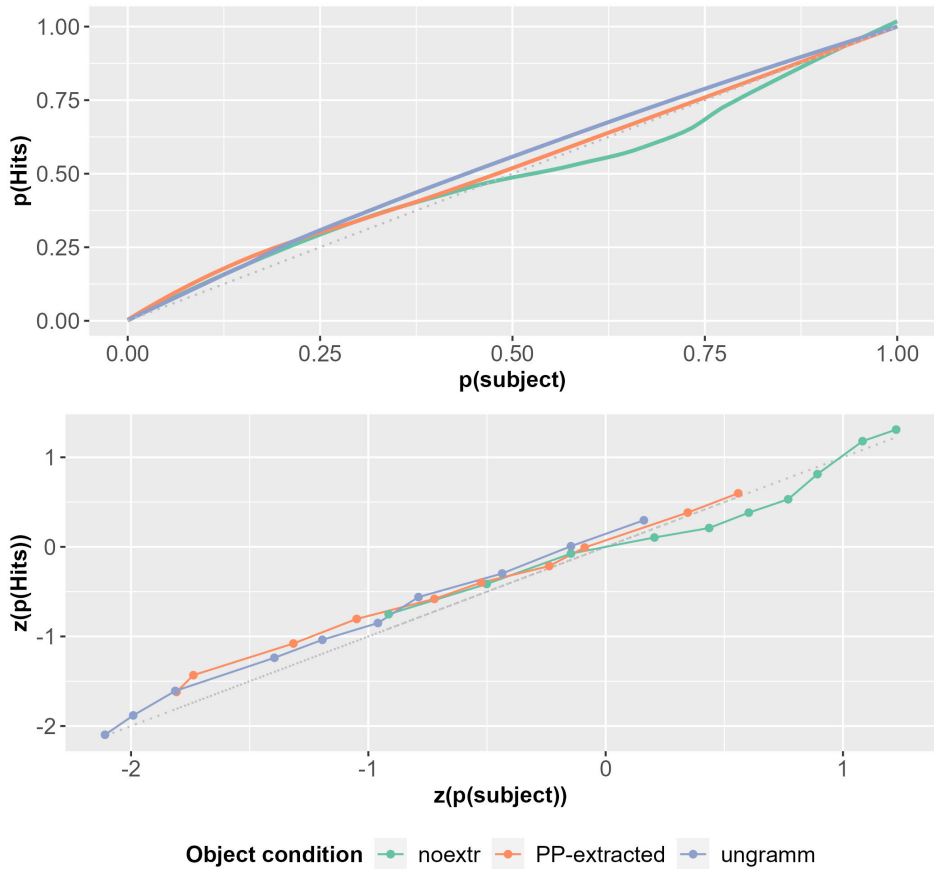

Figure 11.26: ROC curves (top) and zROC curves (bottom) of the object conditions compared to their respective subject conditions, represented by the dotted grey baseline (Dillon & Wagers 2019's method) in Experiment 13.



Habituation is stronger in extraction out of the object than in extraction out of the subject (but not significantly: see model n°2 below).

Acceptability of the ungrammatical controls at the end of the experiment was not lower than the subextraction conditions at the beginning of the experiment. Given that the ungrammaticality comes from the lack of a preposition, it can be overlooked relatively easily if participants are not paying enough attention. The habituation could therefore be due to “noisy channel” effects, i.e. participants’ attention dwindling throughout the experiment.

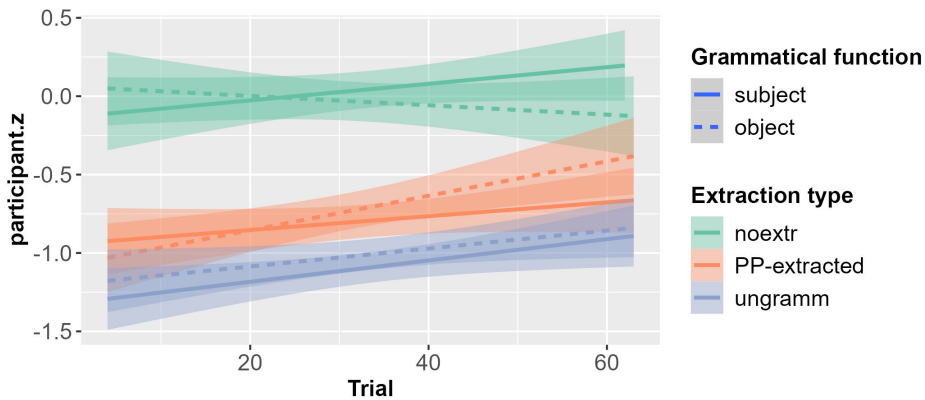

Figure 11.27: Changes in the mean acceptability ratings (z-scored by participant) by condition in the course of Experiment 13

### 11.6.5.2 Comparing subextraction from the subject with subextraction from the object

We fitted a first model to compare extractions out of the subject and out of the object on their own (mean centered with subject coded negative and object coded positive). We included trial number as a covariate, and random slopes for all fixed effects and covariates grouped by participants and items. The results of the model are reported in Table 11.15. There is a significant effect of habituation, but no main effect of syntactic function: extractions out of the subject do not have significantly lower ratings than extractions out of the object.

A second model compared extractions out of the subject and out of the object on their own, crossing syntactic function with trial number. We included participants and items as random factors. The results of the model are reported in Table 11.16. The results for the main effects are similar to model n°1, but we can see that the interaction is not significant. The stronger habituation effect on

## 11 Empirical data on questions

Table 11.15: Results of the Cumulative Link Mixed Model (model n°1)

	Estimate	SE	$z$	$\Pr(>  z )$	OR
syntactic function	0.114	0.118	1	0.334	1.12
trial	0.023	0.009	2	<0.05	1.02

extractions out of the object that we can see in Figure 11.27 is not significant, either.

Table 11.16: Results of the Cumulative Link Mixed Model (model n°2)

	Estimate	SE	$z$	$\Pr(>  z )$	OR
syntactic function	-0.165	0.240	-1	0.4918	1.18
trial	0.022	0.006	3	<0.001	1.02
syntactic function:trial	0.008	0.007	1	0.2153	1.01

In a third model, we compared subextraction with non-extraction. We fitted a model crossing syntactic function and extraction type (mean centered with extraction coded positive, non-extraction coded negative). We included trial number as a covariate, and random slopes for all fixed effects and covariates grouped by participants and items. The results of the model are reported in Table 11.17. There is a significant main effect of extraction type (non-extractions are rated higher). There is no significant main effect of syntactic function, no significant main effect of habituation, and no significant interaction effect. The results are the same if we compare the the AUCs (green and red curves on Figure 11.26): the difference is not significant. Figure 11.28 illustrates this: we see a slight tendency toward an interaction effect, but it is very small.

Table 11.17: Results of the Cumulative Link Mixed Model (model n°3)

	Estimate	SE	$z$	$\Pr(>  z )$	OR
syntactic function	0.057	0.092	1	0.5373	1.06
extraction type	-1.221	0.160	-8	<0.001	3.39
trial	0.011	0.010	1	0.2402	1.01
syntactic function:extraction type	0.048	0.104	0	0.6406	1.05

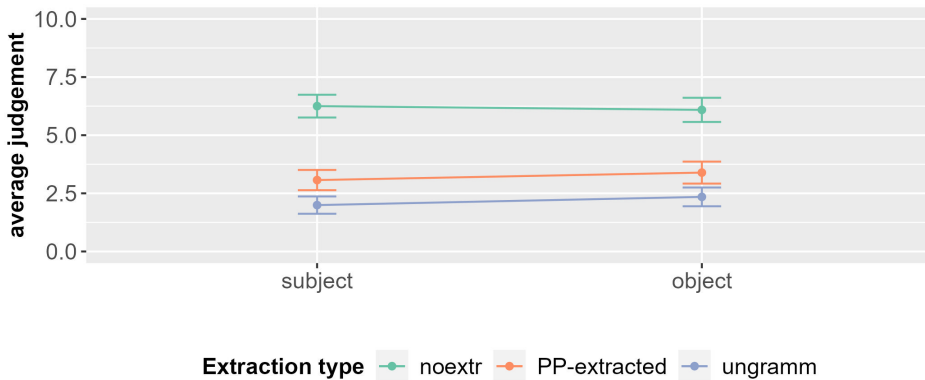

Figure 11.28: Interaction between syntactic function and extraction type in Experiment 13

### 11.6.5.3 Comparing subextraction from the subject with ungrammatical controls

We fitted a fourth model to compare the extractions out of the subject and the subject ungrammatical controls on their own (mean centered with subextraction coded positive and ungrammatical coded negative). We included trial number as a covariate, and random slopes for all fixed effects grouped by participants and items. The results of the model are reported in Table 11.18. There is a significant effect of extraction type: ratings for extraction out of the subject are significantly higher than for its ungrammatical control. There is also a significant effect of trial (habituation).

Table 11.18: Results of the Cumulative Link Mixed Model (model n°4)

	Estimate	SE	z	Pr(>  z )	OR
extraction type	0.656	0.143	5	<0.001	1.93
trial	0.026	0.011	2	<0.05	1.03

In a fifth model, we compared subextraction with the ungrammatical controls. We crossed syntactic function (mean centered with object coded positive, subject coded negative) and extraction type (grammaticality). Trial number as also included as an explanatory variable, as well as random slopes for syntactic function and extraction type grouped by participants and items. The results of the

## 11 Empirical data on questions

model are reported in Table 11.19. There is a significant main effect of extraction type (in favor of the extraction conditions) and of trial (habituation). There is, however, no significant main effect of syntactic function and no significant interaction effect.

Table 11.19: Results of the Cumulative Link Mixed Model (model n°5)

	Estimate	SE	$z$	$\Pr(>  z )$	OR
syntactic function	0.134	0.091	1	0.1405	1.14
extraction type	0.631	0.133	5	<0.001	1.88
trial	0.025	0.005	5	<0.001	1.03
syntactic function:extraction type	0.009	0.088	0	0.9142	1.01

### 11.6.6 Discussion

In this experiment on long-distance dependencies, we see no typical “island” effect when extracting out of the subject. The mean acceptability rating for extraction out of the subject was slightly under the mean acceptability rating for objects, but the difference is not significant (model n°1) and there is no interaction when comparing with non-extraction controls (model n°3). The results are more similar to the results on long-distance dependencies in relative clauses (Experiment 4) than to the results for the other interrogatives with an extraction (Experiment 10 and 12).

As such, the results do not falsify any account. Only the finding that the extraction out of the subject received significantly higher ratings than its ungrammatical control goes against the predictions of the syntactic account.

The ratings in the non-extraction conditions are relatively low compared to the other experiments. This can of course be an accident, be related to the items, or to the choice of distractors, but it may well be due to the embedded structure itself. However, we did not see a similar effect in the relative clauses with long-distance dependencies.

## 12 Experiment on *c'est*-clefts

I have presented a series of experiments on relative clauses and a series of experiments on interrogatives that show a strong cross-construction difference. Usually, approaches to subject islands expect all extractions to have a similar behavior. Only the FBC constraint predicts the results we have observed in the previous experiments. This chapter is about another construction: *it*-cleft sentences (*c'est*-cleft in French).

I will discuss the discourse status of the different elements in *it*-clefts, and explain why *it*-clefts are a good way to test the predictions of the FBC constraint. I will then report on an experiment:

*Experiment 14:* In this acceptability judgment study, we crossed extraction type (subextraction/non-subextraction) with syntactic function (subject/object) and tested *c'est*-clefts. The extraction out of the subject received significantly lower ratings than extraction out of the object, but significantly higher than ungrammatical controls. There was no significant interaction.

### 12.1 Information structure of *c'est*-clefts

French *c'est*-clefts are similar to English *it*-clefts at the level of syntax, but show some subtle differences from their English counterpart with respect to pragmatics. Two parts can be identified in this construction, as illustrated in (12.1): the pivot and the *that*-clause (or *que*-clause in French).

- (12.1) a. [It is tomorrow<sub>i</sub>]<sub>pivot</sub> [that we have to leave <sub>-i</sub>]<sub>that-clause</sub>.  
b. [C' est demain<sub>i</sub>]<sub>pivot</sub> [que nous devons partir <sub>-i</sub>]<sub>que-clause</sub>.  
it is tomorrow that we must leave.INF

*It*-clefts are a special kind of filler-gap dependency. The pivot comprises an expletive *c(e)* 'it', the copula *est* 'is' and an argument: it is a XP that I will designate in the following as the "filler" of the *it*-clefted structure, even though strictly speaking it is not a filler from the syntactic point of view. In an *it*-cleft construction, the filler is focused (Lambrecht 1994). The extracted element is then presupposed to be exhaustive relative to the proposition expressed by the *que*-clause.

The kind of focus involved in *it-clefts* has been discussed extensively (see Destruel et al. (2019) for an overview). Prince (1978) said that the focus in *it-clefts* is contrastive. However, Destruel (2012) and Destruel et al. (2019) have shown experimentally that the focus in English *it-clefts* and French *c'est-clefts* expresses what they call “contrariness”: “clefts signal a commitment on the part of the interlocutor to a proposition that conflicts with the one the cleft expresses and [...] express opposition to that commitment.” As such, it is a corrective focus more than a contrastive focus. We can illustrate this with the example (12.2) below: the commitment *k* in question here is that Alice told Amy about her surprise party, a commitment to which speaker B is opposed (because speaker B knows that Ken told her about it). The strength of the commitment varies in (12.2) depending on speaker A’s utterance. In (12.2a), it is non-existent: there is no reason for speaker B to assume that speaker A is committed to *k*. In (12.2b), the commitment is present, but weak: speaker A does not seem strongly committed to *k*. In (12.2c), the commitment is strong, stronger than in (12.2b): speaker B has every reason to assume that A has a strong commitment to *k*.

- (12.2) a. Non-contradictory:  
 Speaker A: We were planning Amy’s surprise party for weeks. I can’t believe she found out about it. I guess someone from the staff told her.  
 Speaker B: Actually, it’s Ken who told her about it.
- b. Weak commitment:  
 Speaker A: We were planning Amy’s surprise party for weeks. I can’t believe she found out about it. I guess Alice must have told her.  
 Speaker B: Actually, it’s Ken who told her about it.
- c. Strong commitment:  
 Speaker A: We were planning Amy’s surprise party for weeks. I can’t believe she found out about it. Alice told her about it, you know.  
 Speaker B: Actually, it’s Ken who told her about it.  
 (examples from Destruel et al. 2019: 5)

The results of an experiment conducted by Destruel et al. (2019) using materials similar to (12.2) show that the strength of the commitment *k* is a good predictor for the acceptability of the *it-cleft* (speaker B’s utterance): the stronger the commitment, the higher the acceptability. Destruel et al. (2019) conclude that the focus of *it-clefts* (at least in French and English) does not merely express contradiction: both (12.2b) and (12.2c) contradict A’s statement, so if this were the

only factor then they should not differ in acceptability. Contrariness, however, incorporates strength of commitment in addition to contradiction.

Destrueel (2012) also shows that French *c'est*-clefts can mark information focus. This kind of focus can range over the whole sentence (broad focus) or over one element (narrow focus). Having main stress on the beginning of an intonational phrase is strongly dispreferred in French. Therefore, it is dispreferred – though not at all infelicitous – to mark narrow information focus on the subject via intonation. Instead, a frequent and preferred option in French is to use clefted subjects (i.e. fillers in the pivot corresponding to a subject gap in the *que*-clause) for this purpose.

For the same reason, there is a preference for clefted subjects over clefted objects (as experimentally shown by Destrueel (2012) and Destrueel et al. (2019)), even though the latter are also fully acceptable. In English we don't see a similar preference, subjects can be in situ and receive main stress without a problem.

## 12.2 Experiment 14: Acceptability judgment study on *c'est*-clefts

If *it*-clefts are focalization, extraction out of the subject by means of *it*-clefting should be more similar to interrogatives than to relative clauses. This is an important test of the FBC constraint, because *it*-clefts are at the same time syntactically closer to relative clauses than to interrogatives. That is why I close this series of experiments on subextraction from subject NPs by testing *c'est*-clefts.

### 12.2.1 Design and materials

To construct the stimuli for Experiment 14, we used the items already tested in Experiments 4, 10, 11 and 13 and turned the items into *c'est*-clefts. We tested *c'est*-clefts with a short-distance dependency. Subextraction from the subject placed the *de*-complement into the pivot.

- (12.3) a. Condition subject + PP-extracted:  
 [C' est [de cette innovation]<sub>i</sub> que [l' originalité \_]  
 it is of this innovation that the uniqueness  
 enthousiasme mes collègues sans aucune raison.  
 excites my colleagues without any reason  
 'It is of this innovation that the uniqueness excites my colleagues  
 for no reason.'

12 Experiment on *c'est-clefts*

- b. Condition object + PP-extracted:

C' est [de cette innovation]<sub>i</sub> que mes collègues admirent [l'  
it is of this innovation that my colleagues admire the  
originalité <sub>-i</sub>] sans aucune raison ?  
uniqueness without any reason

'It is of this innovation that my colleagues admire the uniqueness  
for no reason.'

It is not possible to form *c'est-clefts* without extraction, so we used as felicitous control extraction of the whole subject (12.4a) or of the whole object (12.4b).

- (12.4) a. Condition subject + noextr:

C' est l' originalité de cette innovation qui  
it is the uniqueness of this innovation that.SUBJ  
enthousiasme mes collègues sans aucune raison.  
excites my colleagues without any reason

'It is the uniqueness of this innovation that excites my colleagues  
for no reason.'

- b. Condition object + noextr:

C' est l' originalité de cette innovation que mes collègues  
it is the uniqueness of this innovation that my colleagues  
admirent sans aucune raison.  
admire without any reason

'It is the uniqueness of this innovation that my colleagues admire  
for no reason.'

The ungrammatical controls were constructed by leaving out the preposition of the extracted element in subextraction conditions.

- (12.5) a. Condition subject + PP-extracted:

[C' est cette innovation que l' originalité enthousiasme mes  
it is this innovation that the uniqueness excites my  
collègues sans aucune raison.  
colleagues without any reason

'It is this innovation that the uniqueness excites my colleagues  
for no reason.'



- b. Condition object + PP-extracted:  
 C' est cette innovation que mes collègues admirent l'  
 it is this innovation that my colleagues admire the  
 originalité sans aucune raison ?  
 uniqueness without any reason  
 'It is this innovation that my colleagues admire the uniqueness  
 for no reason.'

We tested the same 24 items as in Experiment 4, 10, 11 and 13, each manipulated according to the six conditions described above. In addition, the experiment included 24 distractors. The distractors were declarative sentences. About two third of the experimental items and distractors were followed by a comprehension question. The sample item above was paired with the comprehension question *Est-ce que les collègues ont raison d'être enthousiastes ?* ('Are the colleagues right to be enthusiastic?').

### 12.2.2 Predictions

As discussed before, the FBC constraint is the only approach that assumes a difference between constructions. *C'est*-clefts imply the focalization of the extracted element, and for this reason, under the FBC constraint, we expect the results of Experiment 14 to be similar to the findings on the interrogatives (at least interrogatives with an extraction).

The predictions of the other accounts remain the same, except for the processing account based on linear distance. The non-subextraction conditions in this experiment involve extraction. The contrast between extraction of the subject and extraction of the object has been studied extensively (especially for relative clauses): extraction of the subject is rated higher, read faster and processed more easily than extraction of the object (Gibson 1998, Pozniak & Hemforth 2015 to name just a few references on this topic).

This subject preference is compatible with processing accounts based on linear distance, and sometimes motivated these accounts in the first place. However, in the present experiment, it should not lead to the interaction effect we have previously observed: There is one referent between the filler and the gap in the subject subextraction condition (sg.) (12.3a) and none in the extraction of the subject (12.4a), while there are three referents between the filler and the gap in the object subextraction condition (sg.) (12.3b) and two in the extraction of the object (12.4b).

All predictions for *c'est*-clefts are summarized in Table 12.1.

Table 12.1: Predictions of the different accounts for Experiment 14 (clefts). Notes: (a) Condition subject + PP-extracted (b) Condition object + PP-extracted (c) Condition subject + whole NP extracted (d) Condition object + whole NP extracted (e) Condition subject + ungrammatical (f) Condition object + ungrammatical.

	Predictions			
	"traditional" syntactic account	"subject island" accounts processing account with surprisal due to subject complexity	BCI account (Goldberg 2006)	no-island accounts account based on linear distance (DG, DLT) FBC constraint account
extractions out of the subject vs. extractions out of the object	(a) < (b)	(a) < (b)	(a) < (b)	(a) < (b)
extractions vs. non-extractions	main effect of extraction + interaction effect such that (a) < (b,c,d)	main effect of extraction + interaction effect such that (a) < (b,c,d)	main effect of extraction + interaction effect such that (a) < (b,c,d)	main effect of extraction + interaction effect such that (a) < (b,c,d)
extractions out of the subject vs. ungrammatical controls	(a) ≈ (e)	(a) > (e)	(a) > (e)	(a) > (e)
extractions vs. ungrammatical controls	interaction effect such that (b) > (a,e,f)	main effect of grammaticality	main effect of grammaticality	main effect of grammaticality

### 12.2.3 Procedure

We conducted the experiment on the Ibx platform (Drummond 2010). The procedure was similar to the procedure used in the previous acceptability judgment experiments (see Section 8.2.3). Participants rated the sentences on a Likert scale from 0 to 10, 0 being labeled as “bad” and 10 being labeled as “good”. They also answered comprehension questions after some of the sentences.

The experiment took approximately 20 minutes to complete.

### 12.2.4 Participants

The study was run between April and May 2019. Participants were recruited on the R.I.S.C. website (<http://experiences.risc.cnrs.fr/>) and on social media (e.g. Facebook). They received no financial compensation.

24 participants took part in the experiment. The analysis presented here is based on the data from the 21 participants who satisfied all criteria. They were aged 22 to 76 years. 17 of them self-identified as women, 4 self-identified as men. Six of them (12.77%) indicated having an educational background related to language.

### 12.2.5 Results and analysis

Figure 12.1 shows the results of the acceptability judgment task. The ratings for the subextraction conditions were relatively low. The extraction out of the subject (12.3a) received a mean rating of 2.60, which is lower than the mean rating of 3.75 in the extraction out of the object (12.3b). The grammatical controls had high ratings: 7.93 in the subject control condition (12.4a), and 7.70 in the object control condition (12.4b). The ungrammatical controls received the lowest ratings: 2.15 in the subject condition (12.5a), and 2.07 in the object condition (12.5b).

Figure 12.1 suggests a potential ceiling effect in the grammatical controls and a potential floor effect in the ungrammatical controls. Figure 12.2 indicates the same, but the distribution in the subextraction conditions seems relatively normal.

Another representation of the results is provided by the ROC and zROC curves of the results in Figure 12.3 on page 345. The ROC curves show that participants discriminated between the ungrammatical baselines and the other conditions, even though the subextraction from subject condition is close to the baseline. Corroborating what we see on Figure 12.1, the non-subextraction conditions build larger curves than the subextraction conditions. The zROC curves are relatively straight and parallel to the baseline.

## 12 Experiment on c'est-clefts

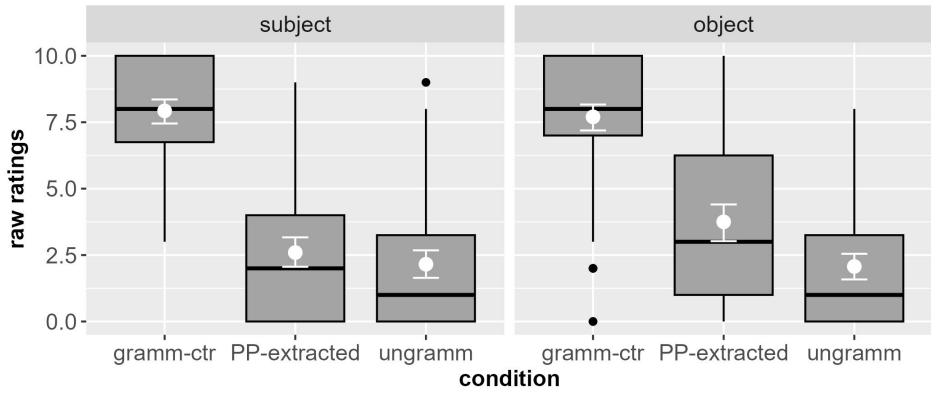

Figure 12.1: Acceptability judgments by condition in Experiment 14. The grey box plots indicate the median and quartiles of the results. Black points are outliers. Mean and confidence intervals are indicated in white.

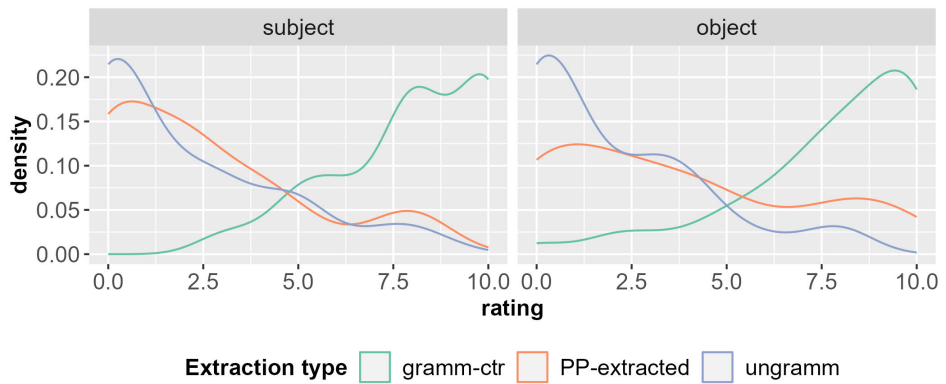

Figure 12.2: Density of the ratings across conditions for Experiment 14

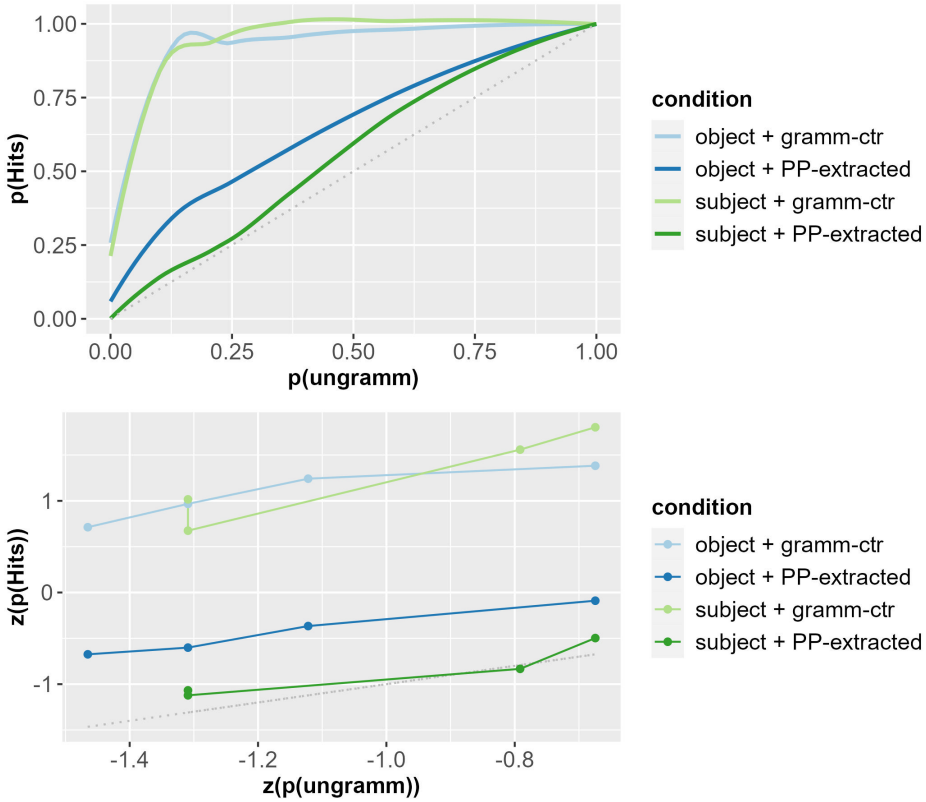

Figure 12.3: ROC curves (top) and zROC curves (bottom) of the non-extraction conditions compared to their respective subextraction conditions, represented by the dotted grey baseline (Dillon & Wagers 2019's method) in Experiment 14.

The ROC and zROC curves in Figure 12.4 on page 346 show the discrimination between the subject and object conditions. The curves for the object condition are barely discriminated from the baseline, except for the subextraction condition, where the difference between the syntactic functions seems more important. The zROC curves indicate that the distribution is not completely normal, except for the subextraction condition that has a straight line parallel to the baseline.

### 12.2.5.1 Habituation

The habituation effects in the course of the experiment are given in Figure 12.5 on page 347. We see some habituation effect in the subject variants of the two controls, but not in their object variants. Subextraction, on the other hand, received similar ratings throughout the whole experiment.

12 Experiment on c'est-clefts

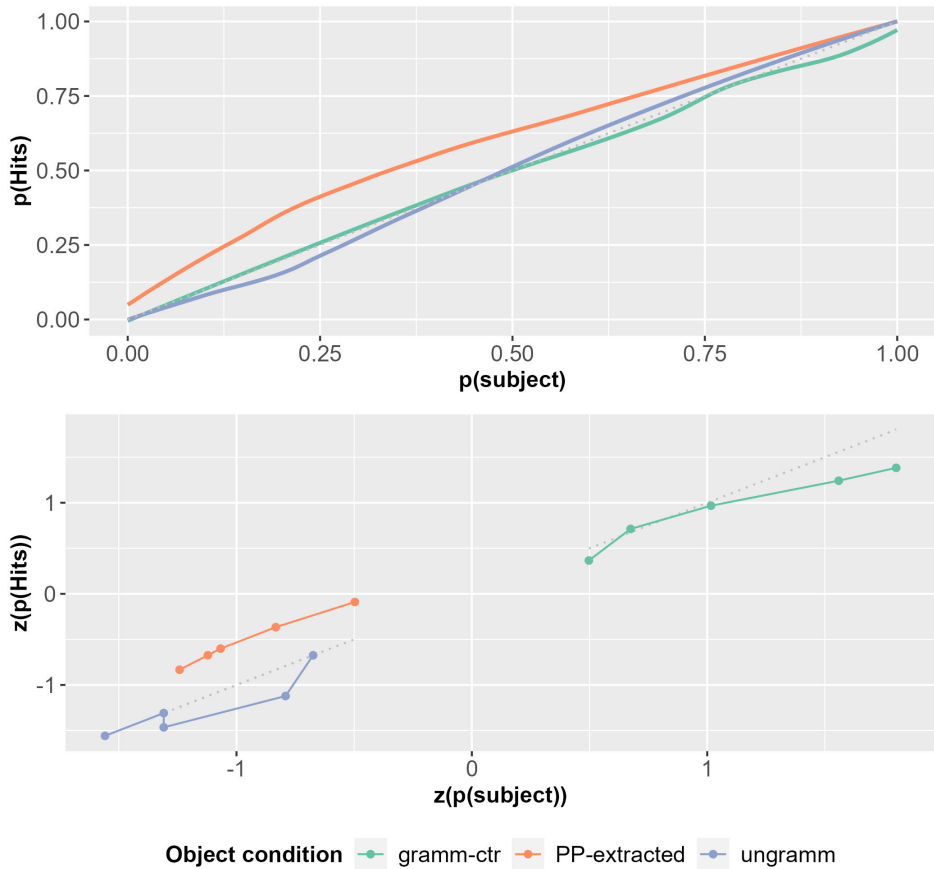

Figure 12.4: ROC curves (top) and zROC curves (bottom) of the object conditions compared to their respective subject conditions represented by the dotted grey baseline (Dillon & Wagers 2019's method) in Experiment 14.

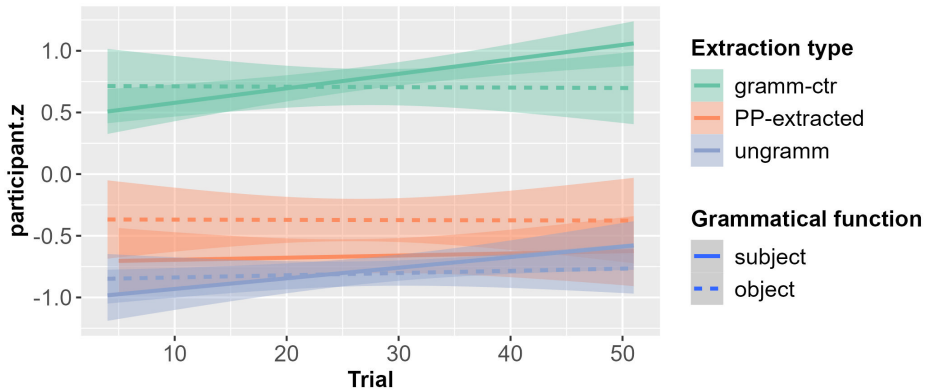

Figure 12.5: Changes in the mean acceptability ratings (z-scored by participant) by condition in the course of Experiment 14

### 12.2.5.2 Comparing subextraction from the subject with subextraction from the object

We fitted a first model to compare the extractions out of the subject and out of the object on their own (mean centered with subject coded negative and object coded positive). We included trial number as a covariate, and random slopes for the fixed effect and the covariates grouped by participants and items. The results of the model are reported in Table 12.2. There is a significant effect of the syntactic function, such that the object condition received significantly higher ratings than the subject condition. As we saw in Figure 12.5, there is no significant effect of habituation.

Table 12.2: Results of the Cumulative Link Mixed Model (model n°1)

	Estimate	SE	z	Pr(>  z )	OR
syntactic function	0.700	0.315	2	<0.05	2.01
trial	0.001	0.014	0	0.9463	1.00

In a second model, we compared the subextractions with the non-subextractions. The model crossed syntactic function and extraction type (mean centered with extraction coded positive, non-subextraction coded negative). We included trial number as a covariate, and random slopes for all fixed effects and covariates grouped by participants and items. The results of the model are reported in

## 12 Experiment on c'est-clefts

Table 12.3. There is a significant main effect of syntactic function (in favor of the object) and a significant main effect of extraction type (non-extractions are rated higher). There is also a significant interaction effect. Figure 12.6 illustrates this effect: we see a decrease of acceptability for the extraction out of subjects. However, if we compare the AUCs (green and red curves on Figure 12.4), the difference is not significant. The two methods thus lead to different results as far as the interaction effect is concerned.

Table 12.3: Results of the Cumulative Link Mixed Model (model n°2)

	Estimate	SE	z	Pr(>  z )	OR
syntactic function	0.289	0.145	2	<0.05	1.34
extraction type	-2.547	0.358	-7	<0.001	12.77
trial	0.019	0.011	2	0.0967	1.02
syn. function:extr. type	0.369	0.177	2	<0.05	1.45

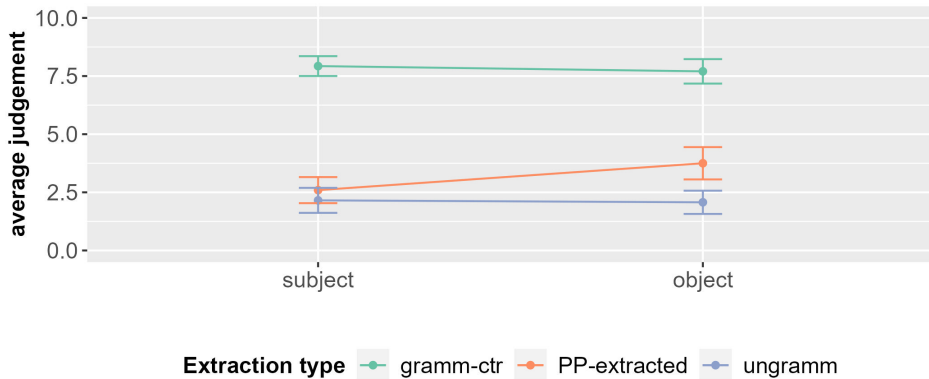

Figure 12.6: Interaction between syntactic function and extraction type in Experiment 14

### 12.2.5.3 Comparing subextraction from the subject with ungrammatical controls

We fitted a third model to compare extraction out of the subject and the subject ungrammatical controls on their own (mean centered with subextraction coded



positive and ungrammatical coded negative). We included trial number as a covariate, and random slopes for the fixed effects and the covariates grouped by participants and items. The results of the model are reported in Table 12.4. There is a significant effect of extraction type, such that the ratings for extraction out of the subject are significantly higher than for its ungrammatical control.

Table 12.4: Results of the Cumulative Link Mixed Model (model n°3)

	Estimate	SE	$z$	$\Pr(>  z )$	Odd.ratio
extraction type	0.450	0.222	2	<0.05	1.57
Trial	0.008	0.020	0	0.6682	1.01

In a fourth model, we compared the subextraction with the ungrammatical controls. We fitted a model crossing syntactic function (mean centered with object coded positive, subject coded negative) and extraction type (grammaticality). We included trial number as a covariate, and random slopes for all fixed effects and covariates grouped by participants and items. The results of the model are reported in Table 12.5. There is a significant main effect of extraction type (in favor of the extraction conditions) and a significant interaction, such that extractions out of the object are rated higher than all other conditions.

Table 12.5: Results of the Cumulative Link Mixed Model (model n°4)

	Estimate	SE	$z$	$\Pr(>  z )$	OR
syntactic function	0.455	0.238	2	0.0557	1.58
extraction type	0.802	0.223	4	<0.001	2.23
trial	-0.005	0.011	0	0.6846	1.00
syntactic function:extraction type	0.368	0.167	2	<0.05	1.45

#### 12.2.5.4 Comparing extraction of the subject with extraction of the object

A fifth model compared the extractions out of the subject and out of the object on their own (mean centered with subject coded negative and object coded positive). We included trial number as a covariate, and random slopes for all fixed effects grouped by participants and items. The results of the model are reported in Table 12.6. There is a significant effect of habituation, but no significant effect

of syntactic function. Extractions of the subject (12.4a) did not get significantly higher ratings than (12.4b).

Table 12.6: Results of the Cumulative Link Mixed Model (model n°5)

	Estimate	SE	$z$	$\Pr(>  z )$	Odd.ratio
syntactic function	-0.003	0.174	0	0.985011	1.00
trial	0.039	0.015	3	<0.01	1.04

### 12.2.6 Discussion

In this experiment, extraction out of the subject received significantly lower ratings than extraction out of the object (model n°1), but this did not lead to a significant interaction (comparison of AUCs). Extraction out of the subject was nevertheless significantly better than its ungrammatical control (model n°3).

The findings that extractions out of the subject have lower ratings than extractions out of the object, and also that there is a significant main effect in favor of objects contradict the expectations of processing accounts based on linear distance. On the other hand, the fact that extractions out of the subject were judged better than the ungrammatical controls contradicts the predictions of the syntactic account.

All other accounts predict a significant interaction effect. The results are contradictory: the interaction is significant with the less conservative method (model n°2), but not with the more conservative one (comparison of AUCs). We cautiously conclude that the null-hypothesis (i.e. that there is no interaction effect) is not falsified, and therefore that the study is inconclusive in this respect. Accounts that predict an interaction effect are not falsified, but it is noticeable that the degradation in extraction out of the subject is less strong in these *c'est-clefts* than in the interrogatives of the previous studies. Indeed, in the corpora, we found extractions out of the subject in *c'est-clefts* (especially an undeniable focalization with example (8.8a) page 126), while we did not find any in interrogatives.

We were not able to reproduce the findings of Destruel (2012) for extractions of the subject (model n°5). This is surprising, because the subject preference has been attested repeatedly for relative clauses. It may be an indication that our experiment is not very powerful (it may not have enough participants), or some unidentified factor affected our stimuli.

## 13 Experiments on infinitival subjects

The results of the previous corpus and experimental studies show that extractions out of subject NP are not islands. More precisely, the constraints we can observe are not specific to subjects or extractions out of subjects.

What about infinitival and sentential subjects? Ross's (1967) original definition of subject island only targeted extractions out of clauses, not out of NPs. Ross (1967) furthermore acknowledges that the subject island constraint may be English-specific, and that Japanese, for example, seems to allow extraction out of sentential subjects.

Sentential and infinitival subjects are hard to target by a corpus study, therefore this chapter presents two experiments on infinitival subjects, the last ones in this book. Both are acceptability judgment studies. The organization of the chapter is the following:

*Experiment 15:* In this acceptability judgment study, we crossed extraction type (extraction/non-extraction) with syntactic function (subject/object) and tested subextraction out of infinitivals. The extracted element was the locative complement of the verb of the embedded clause, the filler was *où*. Extractions out of infinitival subjects were significantly less acceptable than extractions out of infinitival objects (impersonal construction), but the factors did not interact.

*Experiment 16:* In this acceptability judgment study, we crossed extraction type (extraction/non-extraction) with syntactic function (subject/object) and test subextraction out of infinitivals. The extracted element was the direct object of the verb of the embedded clause, the filler was *que*. Extractions out of infinitival subjects received significantly lower mean acceptability ratings than extractions out of infinitival objects (impersonal construction), but this time there was also a significant interaction such that extractions out of the subject had lower ratings than all other conditions.

## 13.1 Experiment 15: Acceptability judgment study on subextraction from infinitivals with *où*

We chose to test infinitival clauses, because extraction out of sentential clauses poses additional problems, as noted by Kluender (2004). Godard (1988: 63) argues that extraction out of finite clauses may be ruled out in general. In their corpus study (see Section 8.1.2), Candito & Seddah (2012a) also find that extraction out of non-finite clauses is much more frequent than extraction out of finite clauses: “We noted that extraction out of finite verbal clause is totally absent from the corpora we’ve annotated (one case only for over 15000 sentences), but extraction out of infinitival clause accounts for one third of the occurrences of the relative pronoun *que*”.

Infinitival subjects are also somewhat more frequent, and therefore more familiar. In the French Treebank (Abeillé et al. 2019), there are only 24 sentential subjects, but 99 infinitival subjects. For comparison, there are 26000 nominal subjects in the same corpus.

### 13.1.1 Design and materials

The experiment used an acceptability judgment task with a 2\*2 design that I explain here in detail.

We based our design on felicitous examples from English, such as the following, which Chaves & Putnam (2020: 105) attribute to Grosu (1981: 72):

- (13.1) a. The ‘Hunan’ restaurant is a place [where]<sub>i</sub> [having dinner <sub>-i</sub>] promises to be most enjoyable.  
 b. The pre-midnight hours are the time [when]<sub>i</sub> [sleeping soundly <sub>-i</sub>] is most beneficial to one’s health.

For this reason, we used verbs that select a locative complement (e.g., *flâner* ‘wander’ or *habiter* ‘reside’) and extract this locative complement with *où* (‘where’). The verb appeared in an infinitival subject clause in the subject condition (8.20a), and in an impersonal construction in the object condition (8.20b).

- (13.2) a. Condition subject + *où* extracted:  
 Amsterdam est connue pour son centre-ville, où<sub>i</sub> [flâner <sub>-i</sub>]  
 Amsterdam is known for its city.center where wander.INF  
 est charmant lorsqu’ il fait beau.  
 is pleasant when it does nice  
 ‘Amsterdam is well-known for its city center, where to wander is pleasant when the weather is nice.’

- b. Condition object + *où* extracted:  
 Amsterdam est connue pour son centre-ville, où<sub>i</sub> il est  
 Amsterdam is known for its city.center where it is  
 charmant [de flâner <sub>-i</sub>] lorsqu' il fait beau.  
 pleasant of wander.INF when it does nice  
 'Amsterdam is well-known for its city center, where it is pleasant  
 to wander when the weather is nice.'

We constructed non-extraction controls by using coordination instead of extraction.

- (13.3) a. Condition subject + noextr:  
 Amsterdam est connue pour son centre-ville, et y  
 Amsterdam is known for its city.center and there  
 flâner est charmant lorsqu' il fait beau.  
 wander.INF is charming when it does nice  
 'Amsterdam is well-known for its city center, and to wander  
 there is charming when the weather is nice.'
- b. Condition object + noextr:  
 Amsterdam est connue pour son centre-ville, et il est charmant  
 Amsterdam is known for its city.center and it is charming  
 d' y flâner lorsqu' il fait beau.  
 of there wander.INF when it does nice  
 'Amsterdam is well-known for its city center, and it is charming  
 to wander there when the weather is nice.'

We created 12 items, each manipulated according to the four conditions just described. In addition, the experiment included 36 distractors. About a third of the experimental items and distractors were followed by a comprehension question. The item presented here as an example was followed by the comprehension question *Est-ce que j'aime me promener dans Amsterdam ?* ('Do I like to take a walk in Amsterdam?').

### 13.1.2 Predictions

The predictions for this experiment are similar to the predictions for relative clauses in general. They are summarized in Table 9.6, which is reproduced here as Table 13.1.

Table 13.1: Predictions of the different accounts for Experiments 15 and 16 (relative clauses). *Notes:* (a) Condition subject + subextraction (b) Condition object + subextraction (c) Condition subject + no extraction (d) Condition object + no extraction.

		Predictions	
		“subject island” accounts	no-island accounts
“traditional” syntactic account		processing account with surprisal due to subject complexity	BCI account (Goldberg 2006)
			account based on linear distance (DG, DLT)
extractions out of the subject vs. extractions out of the object	(a) <(b)	(a) <(b)	(a) >(b) (a) ≥ (b)
extractions vs. non-extractions	main effect of extraction + interaction effect such that (a) <(b,c,d)	main effect of extraction + interaction effect such that (a) <(b,c,d)	main effect of extraction + interaction effect such that (b) <(a,c,d) + no interaction

### 13.1.3 Procedure

We conducted the experiment on the Ibex platform (Drummond 2010). The procedure was similar to the previous acceptability judgment experiments (see Section 8.2.3). Participants rated the sentences on a Likert scale from 0 to 10, 0 being labeled as “bad” and 10 being labeled as “good”. They also answered comprehension questions after some of the sentences.

The experiment took approximately 20 minutes to complete.

### 13.1.4 Participants

The study was run between October 2018 and January 2019. Participants were recruited on the R.I.S.C. website (<http://experiences.risc.cnrs.fr/>) and through social media (e.g. Facebook). They received no financial compensation.

37 participants took part in the experiment. The analysis presented here is based on the data from the 27 participants who satisfied all criteria. They were aged 18 to 90 years. 15 of them self-identified as women and 11 as men. 10 of them (37.04%) indicated having an educational background related to language.

### 13.1.5 Results and analysis

Figure 13.1 shows the results of the acceptability judgment task. All experimental conditions received very high ratings. In the subextraction conditions, the extraction out of the subject (13.2a) had a mean rating of 7.58, lower than extraction out of the object (13.2b) with a mean rating of 8.33. The subject control condition (13.3a) has a mean rating of 8.12, the object control condition (13.3b) a mean rating of 8.41.

Unfortunately, these high ratings suggest that we may have ceiling effects in all conditions. Figure 13.2 suggests the same, even though the ceiling effects seem more substantial in the object conditions.

Another representation of the results is given by the ROC and zROC curves of the results in Figure 13.3. The ROC curves show that participants barely discriminated between the subextraction condition (grey baseline) and the non-extraction controls. The zROC curves are relatively straight, but the curve for subjects deviates from the baseline. Following Dillon & Wagers (2019), this can be a visual cue that there is more variance in one condition. This is in line with the box plots in Figure 13.1 that show more variability in the ratings for the subextraction from subject condition.

### 13 Experiments on infinitival subjects

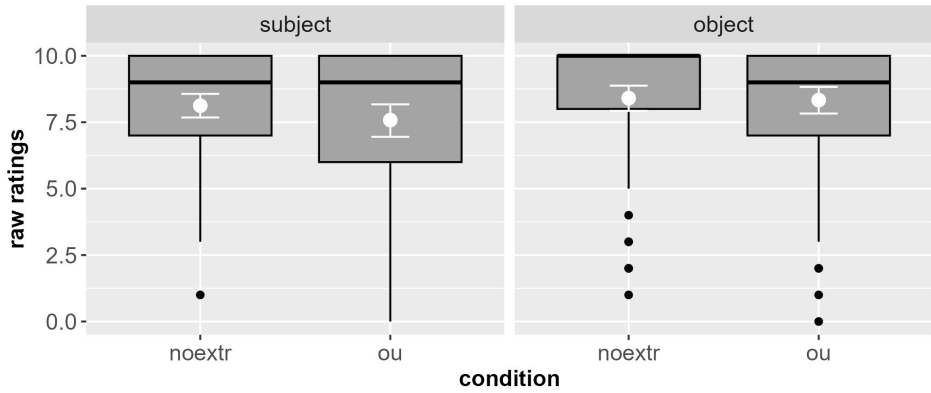

Figure 13.1: Acceptability judgments by condition in Experiment 15. The grey box plots indicate the median and quartiles of the results. Black points are outliers. Mean and confidence intervals are indicated in white.

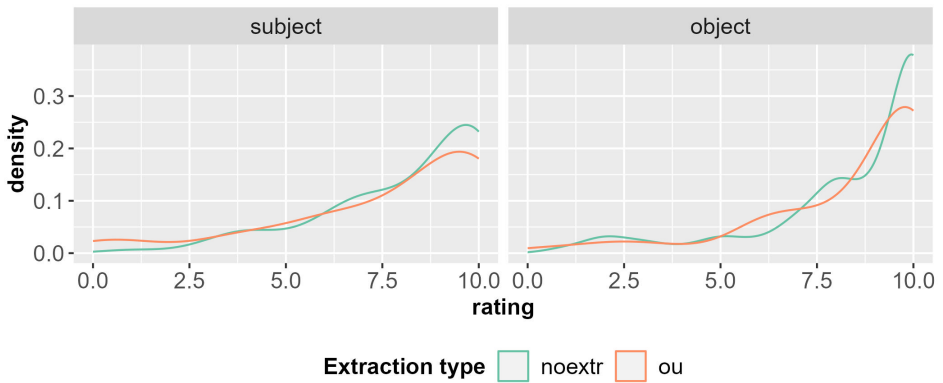

Figure 13.2: Density of the ratings across conditions for Experiment 15



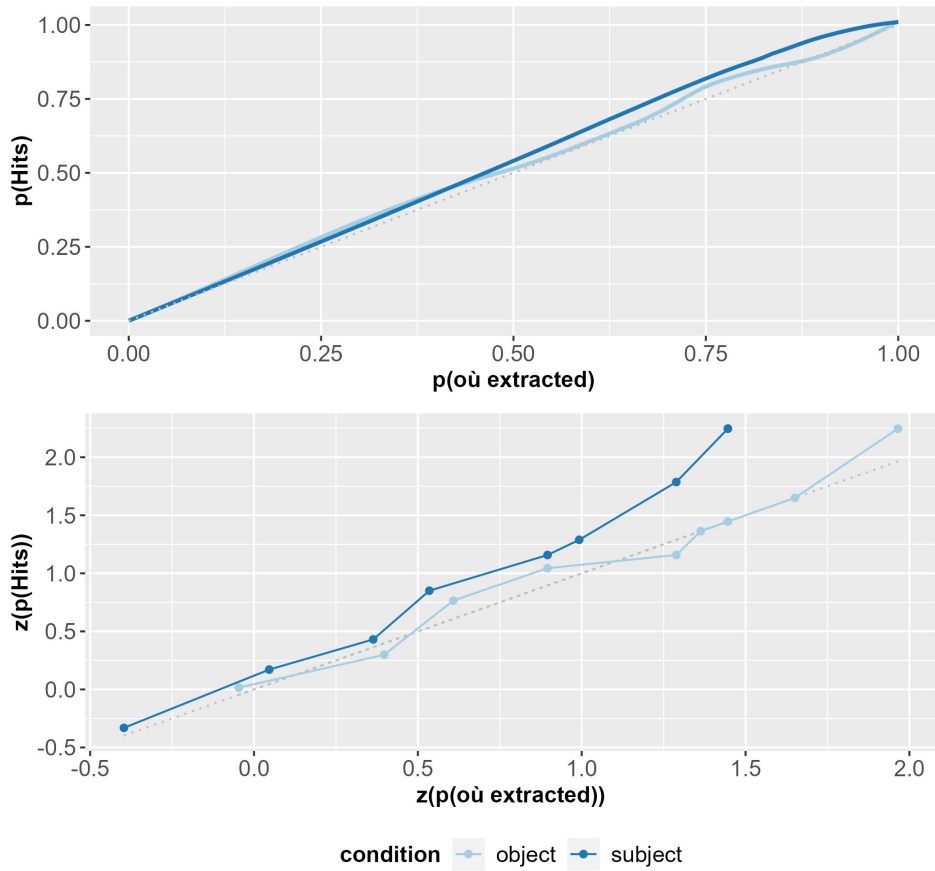

Figure 13.3: ROC curves (top) and zROC curves (bottom) of the non-extraction conditions compared to their respective subextraction conditions, represented by the dotted grey baseline (Dillon & Wagers 2019's method) in Experiment 15.

### 13 Experiments on infinitival subjects

The ROC and zROC curves in Figure 13.4 show the discrimination between the subject and object conditions. We see a weak preference for the two object conditions (curve above the baseline). The zROC curves are relatively straight and parallel to the baseline.

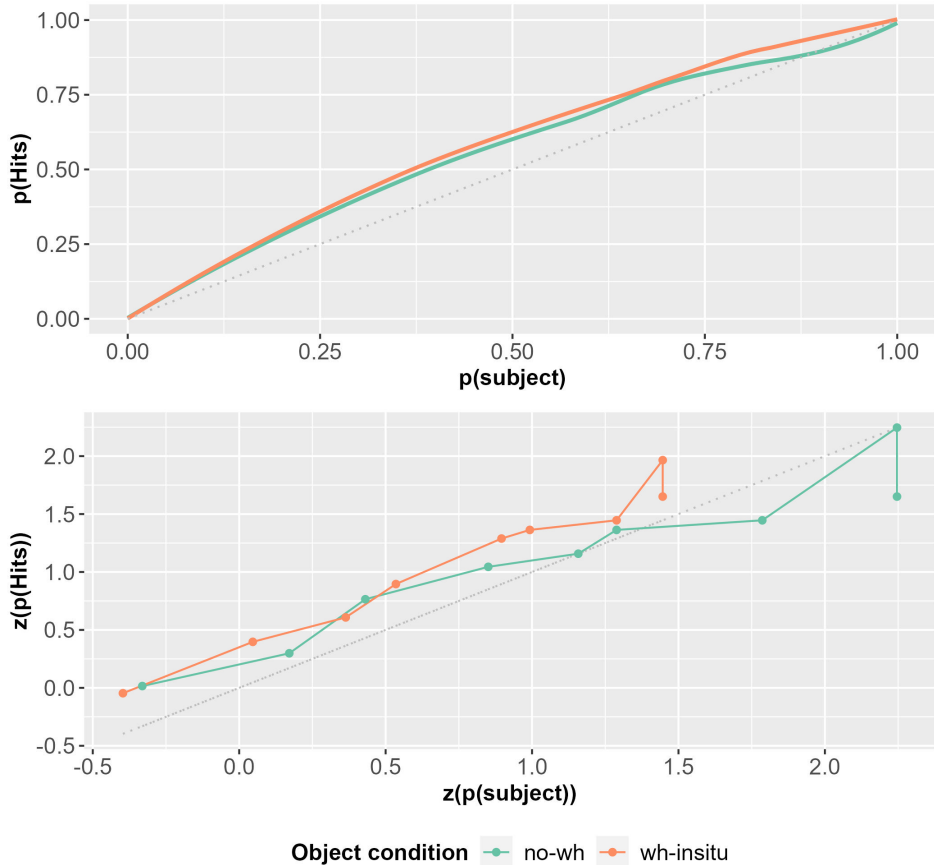

Figure 13.4: ROC curves (top) and zROC curves (bottom) of the object conditions compared to their respective subject conditions, represented by the dotted grey baseline (Dillon & Wagers 2019's method) in Experiment 15.

### 13.1.5.1 Habituation

The habituation effects in the course of the experiment are given in Figure 13.5 on page 359. All conditions except the subextraction from objects show some weak habituation.

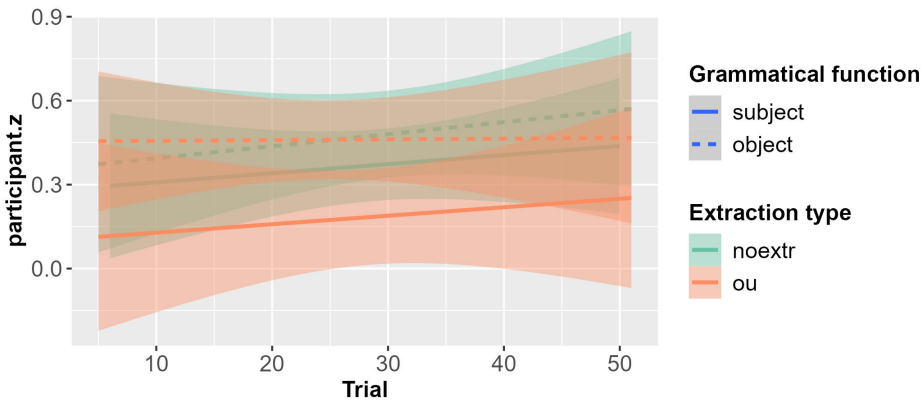

Figure 13.5: Changes in the mean acceptability ratings (z-scored by participant) by condition in the course of Experiment 15

### 13.1.5.2 Comparing subextraction from the subject with subextraction from the object

We fitted a first model to compare extraction out of the subject and out of the object on their own (mean centered with subject coded negative and object coded positive). We included trial number as a covariate, and random slopes for the fixed effect and covariates by participants and items. The results of the model are reported in Table 13.2. There is a significant main effect of the syntactic function, such that the object condition gets significantly higher ratings than the subject condition.

Table 13.2: Results of the Cumulative Link Mixed Model (model n°1)

	Estimate	SE	z	Pr(>  z )	OR
syntactic function	0.388	0.193	2	<0.05	1.47
trial	0.016	0.015	1	0.278	1.02

### 13 Experiments on infinitival subjects

In a second model, we compared subextraction with non-extraction. We fitted a model crossing syntactic function and extraction type (mean centered with extraction coded positive, non-extraction coded negative). We included trial number as a covariate, and random slopes for all fixed effects grouped by participants and items. The results of the model are reported in Table 13.3. The results corroborate the observation based on the zROC curves in Figure 13.4: there is a significant main effect of syntactic function (in favor of the object). However, there is no main effect of extraction type and no significant interaction, even though Figure 13.6 shows a weak tendency toward an interaction effect. If we compare the AUCs (green and red curves on Figure 13.4), the difference is not significant, either. Trial number is also not a significant factor, as Figure 13.5 shows.

Table 13.3: Results of the Cumulative Link Mixed Model (model n°2)

	Estimate	SE	$z$	$\Pr(>  z )$	OR
syntactic function	0.427	0.136	3	<0.005	1.53
extraction type	-0.015	0.163	0	0.9291	1.01
trial	0.016	0.009	2	0.0655	1.02
syntactic function:extraction type	0.093	0.160	1	0.562	1.10

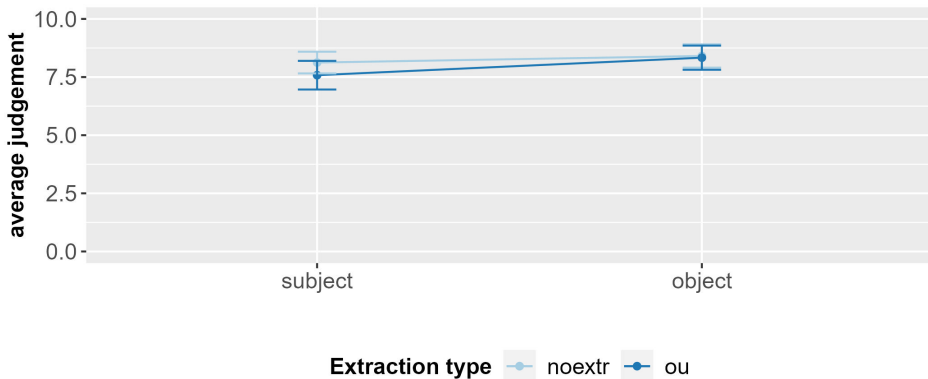

Figure 13.6: Interaction between syntactic function and extraction type in Experiment 15

### 13.1.6 Discussion

The results of the experiment on infinitival subjects show first of all that this kind of subextractions receives very high ratings.

In fact, these high ratings cause a problem in the statistical analysis: given all the ceiling effects we cannot be sure that they do not conceal other significant effects. The ratings for extractions out of the subject are significantly lower than those for extractions out of the object, but there is no detectable interaction effect. Quite possibly, adding more participants (the analysis was based on only 27 participants) or additional complexity to the sentences to reduce ceiling effects would make the interaction significant. This is indeed what we did in the following study (Section 13.2).

However, the mere fact that we are confronted with ceiling effects in extractions out of infinitival subjects is in my opinion strong evidence that the constraint, if there is one, has nothing to do with a syntactic island. There were no ungrammatical controls in this experiment, but there is no doubt that extraction out of the infinitival subject would have been rated higher than ungrammatical controls.<sup>1</sup>

## 13.2 Experiment 16: Acceptability judgment study on subextraction from infinitivals with *que*

Chaves (2013) reports numerous felicitous examples of extraction of the direct object from an infinitival subject:

- (13.4) a. (Huddleston & Pullum 2002: 1094, fn. 27)  
 The eight dancers and their caller, Laurie Schmidt, make up the Farmall Promenade of nearby Nemaha, a town<sub>i</sub> that [[to describe <sub>-i</sub> as tiny] would be to overstate its size].
- b. (Chaves 2013: 471)  
 In his bedroom, [which]<sub>i</sub> [to describe <sub>-i</sub> as small] would be a gross understatement, he has an audio studio setup.

According to corpus results by Candito & Seddah (2012a), it is very frequent to extract with *que* out of a non-finite clause in French. Our intuition, however, was

---

<sup>1</sup>For example, the “ungrammatical” distractors received a mean rating of 4.17. They are relatively acceptable, because they all involve structures with potential agreement attraction like ‘*Le commandant des armées ont attaqué la Biélorussie*. ‘The commander(.sg) of the troops(.pl) attacked(.pl) Belarus’.

### 13 Experiments on infinitival subjects

that sentences like (13.4) are less felicitous than the extraction of a PP tested in Experiment 15. This is why in Experiment 16 we investigated the extraction of an object NP, assuming that a potential contrast between extraction out of subjects vs. objects would be stronger.

#### 13.2.1 Design and materials

The experiment replicated the 2\*2 design of the previous experiment, but used verbs that select a direct object. Whenever possible, we tried to stay close to the items of Experiment 15, and described similar situations. For this reason, many direct objects also denote locations (e.g. *explorer une forêt* ‘explore a forest’).

Again, the subextraction took place from an infinitival subject in the subject condition (8.20a), and from the complement of an impersonal construction in the object condition (8.20b). Non-extraction controls (8.22a) and (8.22c) involved coordination.

- (13.5) a. Condition subject + *que* extracted:  
Amsterdam est connue pour ses péniches, qu<sub>i</sub>’ [observer -<sub>i</sub>] est  
Amsterdam is known for its barges that observe.INF is  
charmant lorsqu’ il fait beau.  
pleasant when it does nice  
‘Amsterdam is well-known for its barges, which to observe is  
pleasant when the weather is nice.’
- b. Condition object + *que* extracted:  
Amsterdam est connue pour ses péniches, qu<sub>i</sub>’ il est charmant  
Amsterdam is known for its barges that it is pleasant  
[d’ observer -<sub>i</sub>] lorsqu’ il fait beau.  
of observe.INF when it does nice  
‘Amsterdam is well-known for its barges, which it is pleasant to  
observe when the weather is nice.’
- c. Condition subject + noextr:  
Amsterdam est connue pour ses péniches, et les  
Amsterdam is known for its barges and them.ACC  
observer est charmant lorsqu’ il fait beau.  
observe.INF is pleasant when it does nice  
‘Amsterdam is well-known for its barges, and to observe them is  
pleasant when the weather is nice.’

- d. Condition object + noextr:  
 Amsterdam est connue pour ses péniches, et il est charmant de  
 Amsterdam is known for its barges and it is pleasant of  
 les observer lorsqu' il fait beau.  
 them.ACC observe.INF when it does nice  
 'Amsterdam is well-known for its barges, and it is pleasant to  
 observe them when the weather is nice.'

We constructed 12 items, based on the items in Experiment 15. Each item was manipulated according to the four conditions just described. In addition, the experiment included 36 distractors, some of which were ungrammatical. Around 40% of the experimental items and 70% of the distractors were followed by a comprehension question. The item presented here as an example was followed by the comprehension question *Il est question de Hambourg.* ('This is about Hamburg.').

### 13.2.2 Predictions

The predictions for this experiment are the same as the predictions for the previous experiment. These were summarized in Table 13.1 on page 354.

### 13.2.3 Procedure

We conducted the experiment on the Ibx platform (Drummond 2010). The procedure was similar to the one used in the previous acceptability judgment experiments (see Section 8.2.3). Participants rated the sentences on a Likert scale from 0 to 10, 0 being labeled as "bad" and 10 being labeled as "good". They also answered comprehension questions after some of the sentences.

The experiment took approximately 20 minutes to complete.

### 13.2.4 Participants

The study was run between May and August 2019. Participants were recruited on the R.I.S.C. website (<http://experiences.risc.cnrs.fr/>) and through social media (e.g. Facebook). They received no financial compensation.

29 participants took part in the experiment. The analysis presented here is based on the data from the 19 participants who satisfied all criteria. They were aged 19 to 76 years. 12 of them self-identified as women, and seven as men. Three of them (15.79%) indicated they had an educational background related to language.

### 13.2.5 Results and analysis

Figure 13.7 shows the results of the acceptability judgment task. In the subextraction conditions, the extraction out of the subject (13.5a) had an mean rating of 4.47, lower than the extraction out of the object (13.5b) which had a mean rating of 6.73. The non-extraction conditions received higher ratings: a mean rating of 8.00 in the the subject control condition (13.5c), and of 7.96 in the object control condition (13.5d).

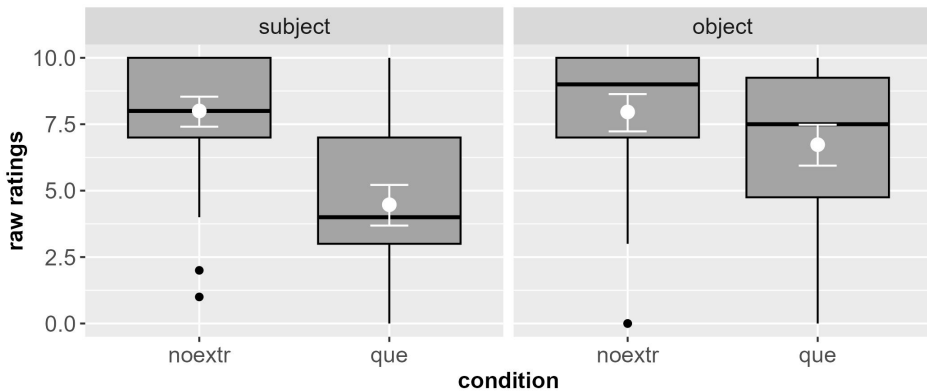

Figure 13.7: Acceptability judgments by condition in Experiment 16. The grey box plots indicate the median and quartiles of the results. Black points are outliers. Mean and confidence intervals are indicated in white.

Figure 13.7 suggests potential ceiling effects in the non-extraction conditions. However, the subextraction conditions seem distributed along the whole scale in this experiment. This is corroborated by Figure 13.8.

Another representation of the results is given by the ROC and zROC curves of the results in Figure 13.9 on page 366. The ROC curves show that participants discriminated between the subextraction conditions and the non-extraction controls. The zROC curve for the subject condition is convex.

The ROC and zROC curves in Figure 13.10 on page 367 show the discrimination between the subject and object conditions. We see that the discrimination is more pronounced for the subextraction than in the non-extraction controls. The zROC curve for the subextraction is slightly convex.

#### 13.2.5.1 Habituation

The habituation effects in the course of the experiment are given in Figure 13.11 on page 368. Habituation effects are absent (or very small) in the non-extraction



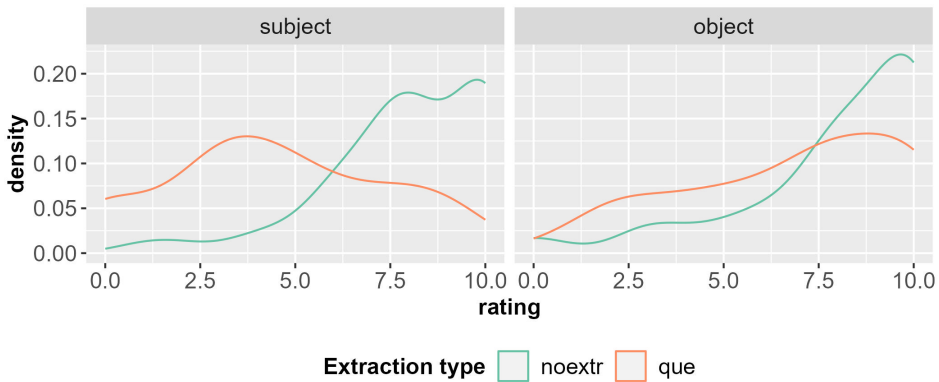

Figure 13.8: Density of the ratings across conditions for Experiment 16

conditions. But the subextraction conditions show a habituation effect, especially in extractions out of the object (although there is no interaction, see below).

### 13.2.5.2 Comparing subextraction from the subject with subextraction from the object

We fitted a first model to compare extractions out of the subject and out of the object on their own (mean centered with subject coded negative and object coded positive). We included trial number as a covariate, and random slopes for the fixed effect and covariates grouped by participants and items. The results of the model are reported in Table 13.4. There is a significant effect of the syntactic function, such that the object condition has significantly higher ratings than the subject condition. There is also a significant effect of trial (habituation).

Table 13.4: Results of the Cumulative Link Mixed Model (model n°1)

	Estimate	SE	$z$	$\text{Pr}(>  z )$	OR
syntactic function	1.328	0.488	3	<0.01	3.77
trial	0.069	0.023	3	<0.005	1.07

We fitted a second model to compare extractions out of the subject and out of the object on their own, and crossed this factor with trial number in order to see if they differ in terms of habituation. We included participants and items as random variables. The results of the model are reported in Table 13.5. The main

13 Experiments on infinitival subjects

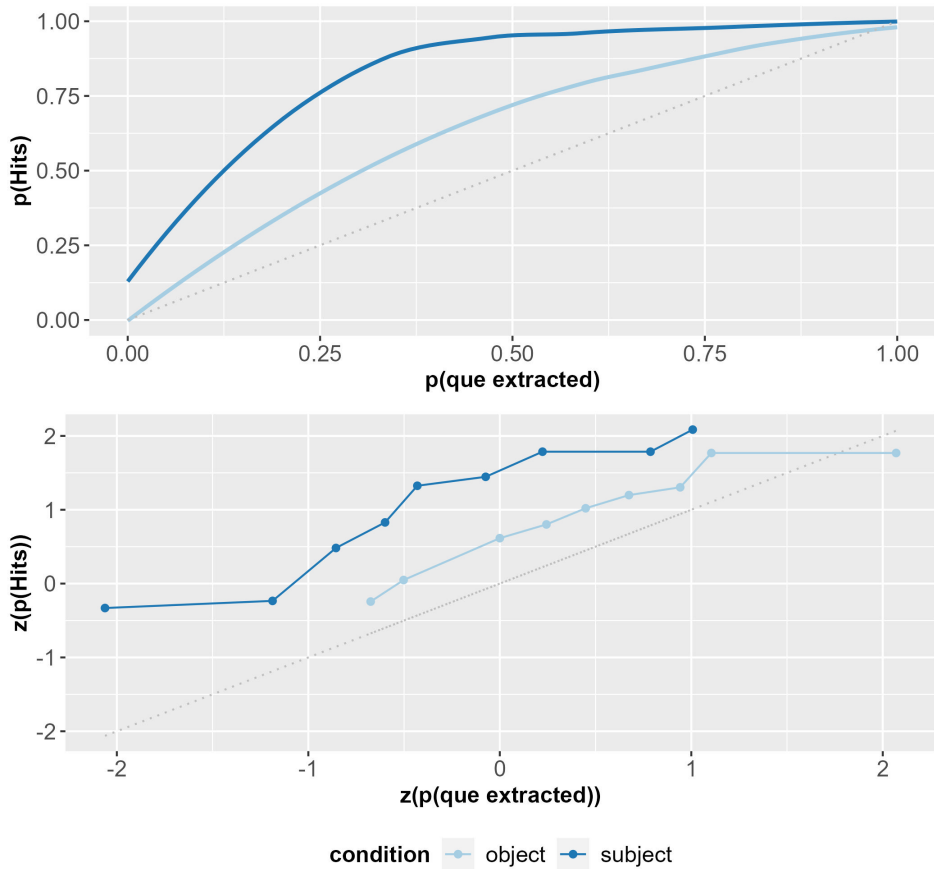

Figure 13.9: ROC curves (top) and zROC curves (bottom) of the non-extraction conditions compared to their respective subextraction conditions, represented by the dotted grey baseline (Dillon & Wagers 2019's method) in Experiment 16.

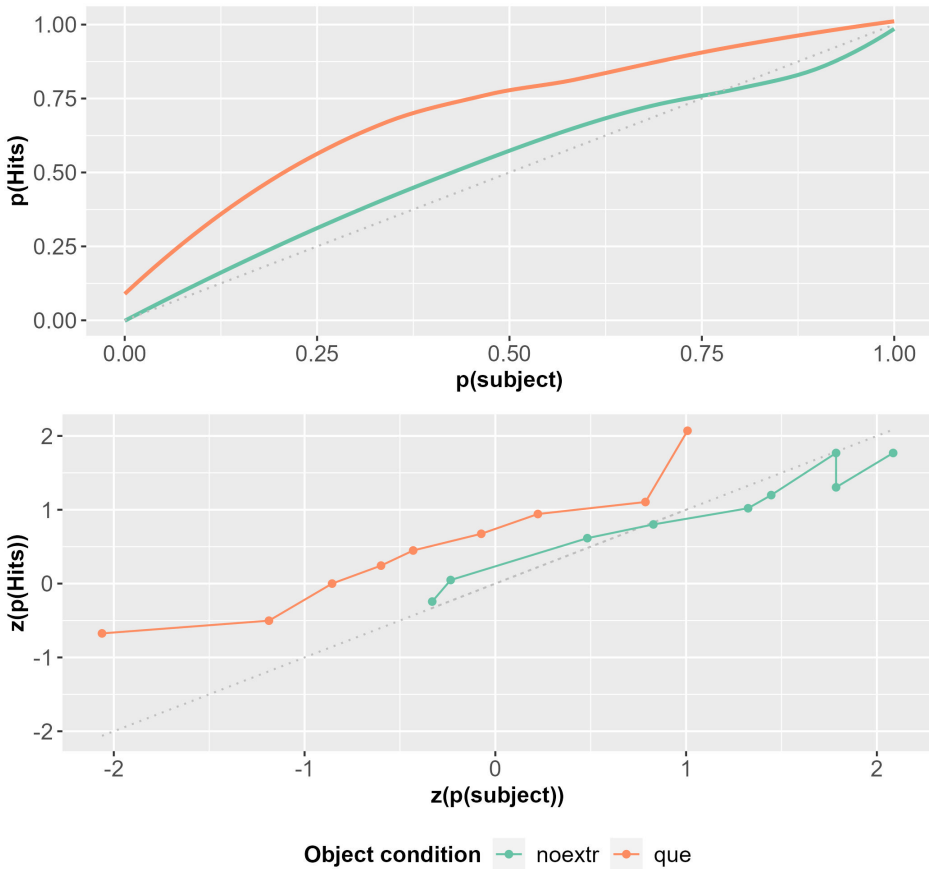

Figure 13.10: ROC curves (top) and zROC curves (bottom) of the object conditions compared to their respective subject conditions, represented by the dotted grey baseline (Dillon & Wagers 2019's method) in Experiment 16.

### 13 Experiments on infinitival subjects

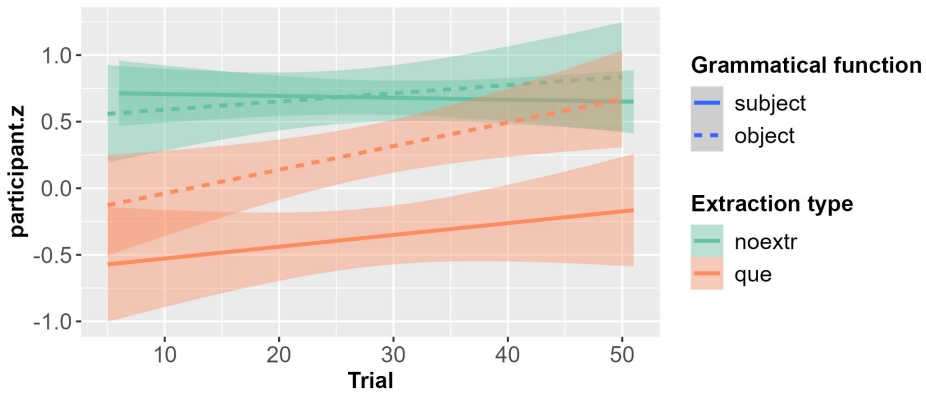

Figure 13.11: Changes in the mean acceptability ratings (z-scored by participant) by condition in the course of Experiment 16

effect of syntactic function which is seen in model n°1 disappears in this model. There is no significant interaction, contrary to the impression we may get based on Figure 13.11.

Table 13.5: Results of the Cumulative Link Mixed Model (model n°2)

	Est.	SE	$z$	$\Pr(>  z )$	OR
syntactic function	0.474	0.465	1	0.307	1.61
trial	0.034	0.014	2	<0.05	1.03
syntactic function:trial	0.014	0.015	1	0.342	1.01

In a third model, we compared the subextractions with the non-extractions. We fitted a model crossing syntactic function and extraction type (mean centered with extraction coded positive, non-extraction coded negative). We included trial number as a covariate, and random slopes for all fixed effects grouped by participants and items. The results of the model are reported in Table 13.6. There is a significant main effect of syntactic function (in favor of the object), a significant main effect of extraction type (non-extraction has higher ratings), and a significant main effect of trial (habituation). There is also a significant interaction effect. Figure 13.12 indeed shows a strong decrease in the ratings for the extraction out of subjects compared to the other conditions. The difference is also significant ( $p < 0.05$ ) if we compare the AUCs (green and red curves on Figure 13.10).

Table 13.6: Results of the Cumulative Link Mixed Model (model n°3)

	Estimate	SE	$z$	$\Pr(>  z )$	OR
syntactic function	0.704	0.285	2	<0.05	2.02
extraction type	-1.455	0.251	-6	<0.001	4.28
trial	0.043	0.012	3	<0.001	1.04
syntactic function:extraction type	0.585	0.229	3	<0.05	1.79

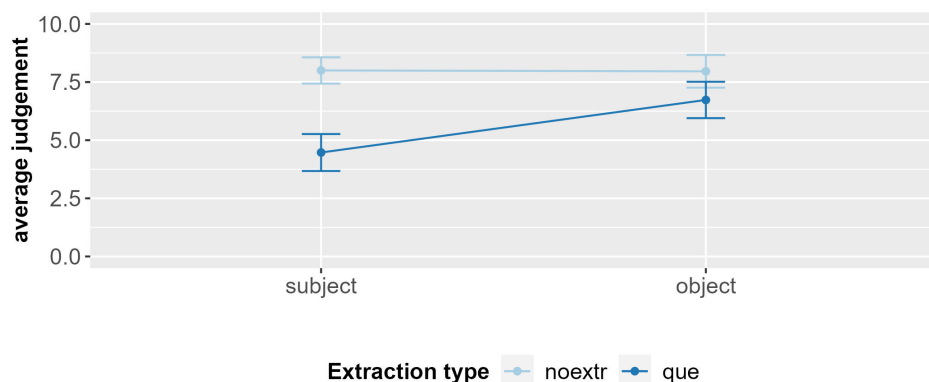

Figure 13.12: Interaction between syntactic function and extraction type in Experiment 16

### 13.2.6 Discussion

The contrast between extraction out of the subject and extraction out of the object is more noticeable in this experiment than in the previous one. In general, subextraction out of an infinitival complement seems more felicitous with *où* than with *que*, because in this experiment we see a main effect of extraction type (model n°3) that we did not observe in Experiment 15.

We see a “subject island effect”: The extraction out of the subject receives significantly lower ratings than the extraction out of the object (model n°1), and there is a significant interaction such that extractions out of the subject had lower ratings than all other conditions (model n°3). However, notice that the significant difference between extraction out of the subject and out of the object disappears if we cross this factor with trial number. Nevertheless, the interaction effect seems strong: it is also significant with the more conservative method of comparing the AUCs.

### *13 Experiments on infinitival subjects*

The ratings for extraction out of the infinitival subject are not very low: 4.47 on a scale of 1 to 10. For comparison, the ungrammatical distractors (wrong subject-verb agreement) received a mean rating of 1.72. Traditional syntactic accounts would not be able to explain such large difference between extraction out of the subject and ungrammatical controls.

## 14 Conclusions on the empirical data

Contrary to an idea strongly anchored in syntax, extraction out of the subject is possible in French. The empirical data in Part II show that extraction out of the subject can be found in the productions of native speakers, and that speakers do not reject it in acceptability judgment tasks.

I was not able to confirm experimentally the observation made by Chaves and his colleagues (Chaves & Dery 2014, 2019, Chaves & Putnam 2020) that extraction out of the subject undergoes strong habituation and that the ratings increase in the course of the experiment. But this is not very surprising, because the number of items in the present experiments is below the threshold considered by these authors as sufficient for observing habituation effects. In general, the habituation patterns seem to be relatively inconsistent, and this factor is rarely significant in my models.

### 14.1 Extraction out of the NP and extraction out of the subject

In general, what we can observe in production data is that extraction out of subjects is very frequent where extraction out of NPs is frequent. In written French, there is no fixed usage of *dont* or any other relative word for extracting the *de*-PP complement of the verb, unlike what Blanche-Benveniste (1990) observed for spoken French. By contrast, extraction of the *de*-complement of the noun out of NPs is frequent in relative clauses. However, in interrogatives, we see a different pattern, namely the *wh*-word is used almost exclusively to extract the complement of the verb and extraction out of NPs is rare. There is also no extraction out of the subject NP in interrogatives. I do not think that this is a coincidence. Indeed we see something similar when we look at *avec qui* relative clauses. On the one hand, almost all occurrences of *avec qui* relative clauses are extractions of the complement of the verb or adjuncts, and extraction out of NPs is very rare, while on the other hand we observe very few examples of extraction out of subjects.

This first observation is compatible with what Kluender (2004) says about extraction out of the subject: Whenever extracting out of an NP is not a frequent option, there seems to be an additional disadvantage for extracting out of the subject compared to extracting out of the object.

This may explain a difference between the results of Experiment 12 and those of Experiments 10, 13, and 14. In Experiments 10, 13, and 14, extraction out of the subject was rated higher than the ungrammatical controls, whereas in Experiment 12 it was not significant. There are several ways to interpret this result. Syntactic accounts would take this as evidence that they are ungrammatical. But the predictions of the syntactic accounts have been falsified on many other occasions in the other experiments. Another option is to appeal to specificity. Indeed, many studies on English so-called “*wh*-islands” show that *which* + N interrogatives are more acceptable than *who/what* interrogatives when the structure is complex. But I propose a different explanation: For some reason, *de qui* is not considered a suitable interrogative phrase for NP subextractions. The evidence for this is that we find almost no *de qui* interrogatives with an NP extraction in corpus studies.<sup>1</sup> Wherever extraction out of the NP is unacceptable, extraction out of the subject is even less acceptable.

But even if we take into account the frequency/acceptability of extraction out of the NP, there is definitely a difference between the constructions. *Avec qui* relatives and *de qui* interrogatives are both used rarely to extract out of the NP, but we find a few examples of extraction out of the subject with the former and none with the latter. This second observation shows that Kluender’s (2004) hypothesis is not sufficient to explain the data, because it does not predict a cross-construction difference. For this, we need the Focus-Background Conflict constraint.

## 14.2 Cross-construction difference

The results of the experiments and of the corpus studies show a clear contrast between non-focalization constructions (the relative clauses) and focalization constructions (interrogatives and *c’est*-clefts) as far as extraction out of a subject is concerned.<sup>2</sup> This contrast is expected according to the FBC constraint, but not expected under any other account that I am aware of. My conclusion is that the FBC

---

<sup>1</sup>Of course, it remains to be explained why *de qui* is not suitable to extract out of an NP, while *dont* is. I have no answer to this question at the moment.

<sup>2</sup>That the results of the experiments are perfectly compatible with the results of the corpus studies provides further support for Bosch et al.’s (2020) observations that the two methodologies yield similar results.



constraint predicts the results of these different experiments best, even though in itself it cannot account for all results.

### 14.2.1 Relative clauses

Production data from the French Treebank and Frantext show that speakers produce extraction out of the subject frequently. In *dont* and *de qui* relative clauses, extracting out of the subject is the most frequent usage of the relative word. In *duquel* relative clauses, it is used more frequently than extraction out of the object, even though it is not the most frequent usage overall. In the experiments, the ratings for extraction out of the subject were significantly higher than those for extraction out of the object in Experiments 1, 4, 7 and 8, with a significant interaction in Experiment 1. In all experiments that include ungrammatical controls (Experiments 4, 7 and 8), the subextraction from the subject was rated significantly higher than its ungrammatical counterpart. Also, reading patterns in Experiment 3 indicated a disadvantage for extraction out of the object, if anything. Overall, the empirical data corroborate Godard's (1988) claim about extraction out of subjects in relative clauses in French.

The lower ratings for extraction out of the subject observed in Experiment 5 are probably an artefact of the material, which had an animacy mismatch between subject and object. As we saw, the disadvantage disappeared when the animacy mismatch was removed in Experiment 7.

The significant interaction in Experiment 1 in favor of the subextraction from the subject should be considered with caution. As I pointed out in the discussions of the experiments, these effects may be an artefact of the stimuli (especially of the choice of coordination with an anaphoric possessive article for the control conditions), but also due to the ceiling effects observed almost systematically for *dont* relative clauses. The preference for extraction out of the subject is expected under accounts based on memory costs, because the filler-gap dependency is shorter in this case. It is not expected according to the FBC constraint. Of course, the two approaches are not incompatible, and my conviction is that a combination of the two predicts the data for relative clauses best. However, my studies do not provide enough evidence for me to conclude that processing accounts based on memory costs are confirmed by the data.

We conducted two corpus studies on Frantext 1900–1913 to see whether there had been a shift in usage over time, but this was not the case: Extraction out of the subject was also frequent at the beginning of the 20th century as well.

The corpus data therefore falsify accounts that predict any form of subject island effect. The experimental results are compatible with them, nevertheless I

want to underline once again that null effects can neither support nor falsify any theory or prediction. As a matter of fact, what we observe in the experiments on relative clauses are mostly null effects. These results are therefore only meaningful because they contrast so undeniably with the results of the experiments on other constructions. On the other hand, the fact that potential “subject island” effects (i.e. interactions between extraction type and extraction site) are systematically absent is a strong cue – even though it is not evidence – that syntactic accounts that expect extraction out of the subject to be completely ruled out by the grammar, cannot be on the right track.

### 14.2.2 Focalizations (interrogatives and *c’est*-clefts)

The results on the interrogatives and clefts are directly opposite to those on the relative clauses. In the corpus studies, we find no extraction out of subjects in interrogatives, and the examples of extraction out of subjects in clefts may be debatable. In the experiments, there is much evidence suggesting a disadvantage for extraction out of the subject. First, it received significantly lower ratings than extraction out of the object in interrogatives with a short-distance dependency (Experiments 10 and 12) and in the *c’est*-clefts (Experiment 14). Second, there is a significant interaction between extraction type and extraction site in interrogatives with a short-distance dependency. Whether there is also a significant interaction in the *c’est*-clefts is not clear: the result is significant in the Cumulative Link Mixed Model, but not when comparing the AUCs (the latter method being more conservative).

These results falsify an approach based on memory costs, which expects that extractions out of the subject should be rated better than extractions out of the object. Even though the other accounts expect a degradation when extracting out of the subject, no account except the FBC constraint can explain the contrast with relative clauses. Furthermore, the syntactic accounts are falsified, because extractions out of the subject should be ruled out by grammar and therefore be as unacceptable as ungrammatical controls. Yet, in Experiments 10, 13 and 14, extraction out of the subject was rated higher than the ungrammatical controls.

#### 14.2.2.1 Interrogatives worse than *c’est*-clefts

Interrogatives have their own pragmatic constraints. One of these constraints is that the presupposed part of the answers must be part of the Common Ground (Simonenko 2016). We can illustrate this requirement with example (14.1).

- (14.1) a. Question: Of which innovation does the uniqueness excite my colleagues for no reason?
- b. One answer alternative: [The uniqueness of the digital bracelet for social distancing]<sub>B</sub> excites my colleagues for no reason.

By default, the whole subject in (14.1b) is presupposed and backgrounded. The pragmatic constraint of questions thus states that the subject of (14.1b) must be part of the Common Ground in (14.1a). Then we are faced with a contradiction: the inquirer asks for information that is presupposed as being part of the Common Ground (a presupposition that they introduced themselves). Simonenko 2016 makes a similar argument about another kind of island. This mechanism may reinforce the FBC constraint and explain why the “island effect” is stronger in interrogatives than in *c’est*-clefts.

#### 14.2.2.2 Exceptions

The interaction showing a dispreference for extraction out of the subject was only found in interrogatives with a short-distance dependency. There are therefore two exceptions: interrogatives with the *wh*-phrase in situ (Experiment 11), and interrogatives with a long-distance dependency (Experiment 13).

In Experiment 11, no significant effect was found, except for a main effect of extraction type. We can conclude that in-situ interrogatives do not behave like interrogatives with extraction as far as the “subject island” is concerned. This is not expected under the FBC constraint, in which extraction plays no role. One way to deal with the issue would be to add extraction to the constraint as a necessary factor. On the other hand, I have shown in the discussion of this experiment that the functional status of in-situ questions is not clear. Possibly the structure is not focalization by default, so the FBC constraint is not violated in in situ questions in French. There is, for the time being, not enough strong evidence to decide between these two possibilities. Therefore, I leave this question open, and will assume the FBC constraint as defined in (4.31).

In Experiment 13, no significant difference was observed between extraction out of the subject and out of the object. This contrasts with Experiment 10 and directly contradicts syntax-based and processing-based accounts. Higher complexity and an increased length of the extraction in long-distance dependencies is predicted by these accounts to lead to a stronger “island effect” than in short-distance dependencies. Is the contrast between Experiment 10 and Experiment 13 problematic for the FBC constraint as well? I think not. First, Experiment 13 may not have been strong enough to reveal a discourse clash due to some factor that

we did not take into account. More importantly, I can easily imagine that the discourse clash becomes weaker, or even disappears in a long-distance dependency. We view information structure as a relation between a constituent and a clause (see Section 15.1). In (14.2), *of who* is by default focused with respect to the matrix clause. But it is not certain that it is focused with respect to the embedded clause.

(14.2) [Of who]<sub>i</sub> do you think [that [the daughter <sub>-i</sub>] plays the piano]?

If *of who* is not the focus of the embedded clause, then there is no discourse clash, and the FBC constraint is not violated. If *of who* is the focus of the embedded clause, then it is likely to be focused to a lesser degree, based on the common assumption that elements may be focused, topic, or backgrounded to a greater or lesser extent. I will come back to this question in Section 15.2.

### 14.2.3 Extraction out of a verbal subject

In Experiments 15 and 16, we looked at extraction out of infinitive subjects. Using *que*, in Experiment 16 we observed an interaction effect, but with *où* in Experiment 15 we did not. Yet these results are not necessarily in conflict. Experiment 15 appeared to have strong ceiling effects, which may mask a potential interaction.

Experiments 15 and 16 pose a problem with respect to the FBC constraint. They are relativizations, so no degradation is expected in the extraction out of the subject. Thus, it seems that the FBC constraint alone cannot explain the results we observe.

Let us consider the other approaches. Distance-based processing accounts do not predict the pattern we observe in Experiments 15 and 16 and can therefore be set aside. Overall, extraction out of the subject received high ratings, which is at odds with the ungrammaticality of these extractions assumed by syntactic accounts. They should therefore be set aside as well. Finally, functional accounts of the type “Backgrounded Constituents are Islands” are inconsistent with the other empirical results I have presented.

Kluender’s (2004) proposal that retrieving complex topics induces higher processing costs seems to account for the findings, and it can be combined with the FBC constraint. We can indeed assume that processing costs are higher when the subject is more complex. NPs including a *de*-PP in French seem relatively simple, NPs with another kind of PP are probably more complex. Verbal subjects are even more complex, but infinitival ones probably less so than sentential ones. This results in a hierarchy of complexity. The more complex the subject, the less expected it is, and the less likely that the addressee predicts a gap inside it. Unexpected gaps create stronger processing costs. As long as these processing costs

are below a certain threshold, they have virtually no effect on the addressee's perception (as in our experiments on relative clauses). In Experiment 16, where the relative word is less specific than in Experiment 15, the threshold is crossed, and we observe a significant interaction, probably caused by more difficulty in extracting out of the subject.

### 14.3 Discourse clash

We cannot reduce the difference between the constructions to an incompatibility in information structure between the extracted element and its head. Although it seems problematic to focalize out of a topic, topicalizing out of focus (or non-topic) is not a problem. This is attested by the examples of extraction out of postverbal subjects that we find in the corpus studies. Following Lahousse (2011), postverbal subjects are less topical than preverbal subjects. In the different corpus studies presented above, we find in total 12 cases of extraction out of a postverbal subject.<sup>3</sup> This means that topicalization out of a less topical element does not lead to a discourse clash. The reason why extraction out of a preverbal subject is much more frequent may be that speakers tend to minimize the distance between the filler and the gap.

### 14.4 Verb types

#### 14.4.1 Extraction out of the subject of transitive verbs

Chomsky (2008) and Polinsky et al. (2013), among other scholars, claim that extracting out of the subject of a transitive verb is degraded compared to extracting out of an “underlying object”, i.e. out of the subject of a passive or unaccusative

---

<sup>3</sup>Lahousse (2011: 261) notes that most of the examples of postverbal subjects in the literature on subject-verb inversions are restrictive. In my corpus studies, all but one cases of extraction out of a postverbal subject are non-restrictive (and the last one reported page 278, (10.13b) is ambiguous, even though it is annotated as restrictive – see our guidelines for annotation in Appendix A). Lahousse claims that inversion is always acceptable in restrictive relative clauses, but not in non-restrictive relative clauses. In a non-restrictive relative clause, she says, there must be a clear indication that the subject is non-topical (e.g., through the presence of a framing topic). I cannot confirm this assertion, and find no special indication that the subject is non-topical in these 12 relative clauses. In four of them, using a preverbal subject would have as a consequence that the verb would stand in the last position, and this is dispreferred in French (still following Lahousse 2011: 261).

verb. In the majority of the corpus studies, there is indeed a significant difference between extraction out of the subject on the one hand and the other relative clauses on the other hand: in extraction out of the subject transitive verbs are significantly less frequent. Although this could mean that extraction out of the subject of transitive verbs is degraded, I will argue that this is not the case, for several reasons. First, the number of transitive verbs found in extractions out of subject NPs is far from marginal. Second, as already mentioned, the results may be biased by the fact that, “other relative clauses” include extractions out of object NPs, which by definition only occur with transitive verbs. But a third argument should also be mentioned.

In Section 3.3.1, we mentioned several corpus studies on English, Italian and Japanese which show that speakers tend to produce fewer complex subjects when the sentence contains a direct object than when it does not. The general rule in production data seems to be: the longer the rest of the VP, the shorter the subject. If we assume that this holds for French as well, then transitive verbs will have more clitic subjects than the other verb types. As it is not possible to extract out of a clitic, it is not surprising that extraction out of subjects involves transitive verbs less often than other types of extractions. We used the corpus study on *duquel* in Frantext to reproduce on a small scale the corpus studies done in other languages. Figure 14.1 shows the distribution of the subject types for the different verb types: the results are given only for pied-piping structures (i.e., *duquel* is the complement of a preposition or the complement of a noun complement of a preposition). Except for a few cases, these pied-piping structures are extractions of the complement of a verb, or are extractions of an adjunct. We can clearly see that transitive verbs have a higher proportion of clitic subjects compared to the other kinds of verbs, as expected.

#### 14.4.2 A remark on psychological verbs

A common concern voiced by reviewers and conference audiences about the experiments presented in Part II has been our use of psychological verbs. The issue is that the subjects of some psych verbs are considered to be underlying objects in some theories. This idea, which only applies to experiencer-object psych verbs, goes back to Belletti & Rizzi (1988), and the various debates have been summarized by Landau (2010). The original claim made by Belletti & Rizzi (1988) was that these verbs are unaccusative, but Legendre (1989) and Herschensohn (1992) have brought some evidence against this for French, summarized as follows by Landau:

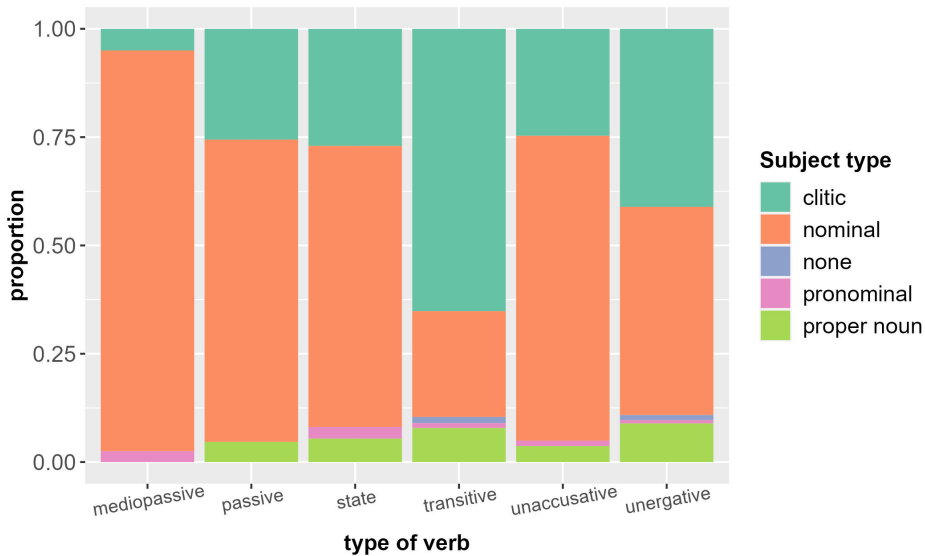

Figure 14.1: Subject type for every verb type in *duquel* relative clauses with a pied-piping structure in Frantext 2000–2013

“On too many points – for example, auxiliary selection, passivization, lexical operations referring to external arguments, compatibility with pure expletives (e.g. *il* vs. *cela* in French) – class II verbs do not pattern with unaccusatives, their subject (a causer rather than a theme) behaving like a normal external argument [...]” (Landau 2010: 38–39)

Nevertheless, Legendre (1989), Herschensohn (1992) and Landau (2010) assume that the stimulus argument of such verbs is a derived subject.

#### 14.4.2.1 Arguments in the literature

Landau (2010) mentions three core arguments in favor of the derived subject hypothesis: experiencer-object psych verbs do not reflexivize, cannot be embedded as infinitival complements of a causative verb, and do not passivize. A careful study of these arguments would go beyond the scope of this work, but here are a few remarks which lead us to think that psych verbs behave like transitives.<sup>4</sup>

Herschensohn (1992) offers the following example to illustrate the impossibility of reflexivizing experiencer-object psych verbs:

<sup>4</sup>Many thanks to Elisabeth Verhoeven for her input on this topic.

#### 14 Conclusions on the empirical data

- (14.3) a. Les enfants se lavent les uns les autres.  
the children REFL wash the ones the others  
'The children wash one another.'
- b. \* Les enfants se préoccupent les uns les autres.  
the children REFL worry the ones the others  
'The children worry one (about) another.'

But, as mentioned by Herschensohn (1992) herself, verbs of this class have pronominal variants. For example, *préoccuper* ('worry') has a ditransitive variant *se préoccuper* ('worry about') with an indirect object, so that there is a straightforward way to express (14.3b), namely (14.4):

- (14.4) Les enfants se préoccupent les uns des autres.  
the children REFL worry the ones of.the others  
'The children worry one about another.'

The second argument relies on causative constructions. The verb *faire* ('to do') can be used to form a causative construction in French, as illustrated by example (14.5). The referent of the causative adverbial in (14.5a) can be the subject of a *faire* + Vinf structure like (14.5b).

- (14.5) a. Jean porte un appareil auditif à cause de son grand âge.  
Jean wears a device hearing at reason of his old age  
'Jean wears a hearing device because of his advanced age.'
- b. Son grand âge fait porter à Jean un appareil auditif.  
his old age makes wear.INF at Jean a device hearing  
'His advanced age makes Jean wear a hearing device.'

The transposition from (14.5a) to (14.5b) is not possible for experiencer-object verbs:

- (14.6) a. La télévision dégoûte Jean à cause de son bruit déplaisant.  
the television disgusts Jean at reason of its noise annoying  
'The television disgusts Jean because of its annoying noise.'
- b. (Kayne 1975: 252)  
\* Son bruit déplaisant fait dégoûter Jean à la télévision.  
its noise annoying makes disgustINF Jean at the television.  
'Its annoying noise makes Jean disgusted by the television.'



According to Burzio (1986), causative constructions can be used as a test to see whether a subject is a derived one. Clauses with derived subjects cannot be embedded as infinitival complements of causative constructions. However, notice that this kind of embedding is infelicitous for any non-agentive subject of a transitive verb, as the following example shows:

- (14.7) a. La grange abrite Jean grâce à son toit solide.  
 the barn protects Jean thanks at its roof robust  
 ‘The barn protects Jean thanks to its robust roof.’
- b. \* Son toit solide fait abriter Jean à la grange.  
 its roof robust makes protect.INF Jean at the barn  
 ‘Its robust roof makes Jean protected by the barn.’

Kayne himself notes that this restriction is lifted in agentive contexts, as reported by Landau (2010: 38). Experiencer-object psych verbs are thus not different from any other non-agentive verbs in this respect. One may argue that all non-agentive subjects are internal arguments, but this goes beyond the analysis of Landau (2010) that we discuss here.<sup>5</sup>

The last claim, made by Legendre and reported by Landau, is that the passive of psych verbs is stative, i.e. that *choqué* in (14.8) is an adjective and not a real passive form.

- (14.8) Pierre est choqué par le film.  
 Pierre is shocked by the movie  
 ‘Pierre is shocked by the movie.’

Legendre’s demonstration relies on two arguments: (i) the impossibility of embedding psych verbs in a causative construction with *faire* and (ii) the impossibility of applying *re*-prefixation. I have just shown that (i) is not a good argument for French. Argument (ii) is the following: the prefix *re*- in French can be used productively to form new verbs, expressing the idea that the event has been repeated. According to Legendre, past participles of experiencer-object verbs cannot undergo *re*-prefixation, which shows that they are adjectives and not verbs. This is illustrated by the contrast between the “real” participle in (14.9a) and the alleged adjective in (14.9b) (the judgments on the examples are in concordance with Legendre’s account):

---

<sup>5</sup>For a discussion of this specific point, see Section 14.4.2.2 below.

## 14 Conclusions on the empirical data

- (14.9) a. Ce film a rechoqué Pierre.  
this movie has shocked.again Pierre  
'This movie shocked Pierre again.'
- b. \* Pierre a été rechoqué par ce film.  
Pierre has been shocked.again by this movie  
'Pierre has been shocked again by this movie.'

My intuition differs from Legendre's in this respect. Both (14.9a) and (14.9b) are relatively infelicitous for me, probably because of the neologism, but I do not have the impression of a strong contrast between the two. Furthermore, if the passive of psych verbs were stative, a construction with *en train de* (equivalent of V+ing in English) should be ruled out. My intuition is that (14.10) is strange, but possible:

- (14.10) ? Pierre est en train d' être choqué par ce film.  
Pierre is in pace of be.INF shocked by the movie  
'Pierre is being shocked by the movie.'

To conclude, the arguments brought in favor of analyzing the subjects of experiencer-object psych verbs as underlying objects are not sufficiently well-grounded. I acknowledge that dedicated work should be done on this topic, but this is not the aim of the present book.

### 14.4.2.2 Consequence for the experiments in this book

Even if the subjects of experiencer-object psych-verbs were not "real" subjects, this would not have a big impact on my experiments and would not account for the results.

In Experiments 1–6, 10, 11, 13 and 14 systematically involve extraction out of the stimulus argument. Therefore, extraction out of subjects in these experiments would be extraction out of underlying objects under the above hypothesis. This could account for the results of the relative clauses (i.e., that native speakers do not reject these sentences), but not for the interaction effects that I find in focalizing constructions (i.e., that extraction out of the subject is rated worse than extraction out of the object). If we inadvertently tested extraction out of objects in all conditions, where does the "subject island" effect come from?

In Experiments 7, 8, 9 and 11, some test sentences contained experiencer-object psych verbs, but they only represent around 1/3 of the items. The other items were extraction out of "real" subjects under Landau's (2010) analysis. Grouping

the results of Experiment 9 according to verb types did not reveal any obvious contrast between the experiencer-object verbs and the other verbs.<sup>6</sup>

## 14.5 A remark on hanging topics

Another recurrent concern about the interpretation of the experimental results is a certain suspicion that relative clauses (or at least some relative clauses) may not involve “real” extraction. This is the argumentation presented by Giorgi & Longobardi (1991: 82–85), and developed extensively by Jurka (2010: Section 5) and Uriagereka (2011: Section 2.3). In a nutshell, their claim is that extraction of a PP-complement out of a subject NP is a bad counterexample to the subject island constraint, because such PP-complements are possible hanging topics (or “aboutness proleptics” in Uriagereka’s (2011) terms). An example of fronted aboutness proleptics in Spanish is given in (14.11), the relevant elements appear in italics.

- (14.11) (Uriagereka 2011: 94)
- De los árboles frutales* me gusta el melocotón, y *de los*  
of the trees fruit-growing me pleases the peach and of the  
*reyes de España* Alphonso de Borbón.  
kings of Spain Alphonso de Borbón  
‘Concerning fruit trees, I like peaches ; and concerning the kings of  
Spain, I like Alphonso de Borbón.’

The English translation makes the aboutness relation of these proleptics transparent. Evidence that the fronted elements are not extracted out of the NPs *el melocotón* and *Alphonso de Borbón* is that neither [*el melocotón de los árboles*] nor [*Alphonso de Borbón de los reyes de España*] is a correct complete NP. Uriagereka and Jurka assume that all examples of felicitous extraction out of NPs in the literature can be considered to be only apparent extraction, and actually showing aboutness proleptics. Hence, following their argument, acceptable cases of pied-piped PPs in English, as in (14.12a), can also be analyzed by treating the fronted element (here *of which politician*) as a proleptic, similarly to what happens in (14.12b) which obviously does not involve extraction.<sup>7</sup>

<sup>6</sup>It would be possible to run additional experiments without any experiencer-object psych verbs. But there is a certain correlation between the type of psych verb (experiencer subject vs. object) and the implicit causativity of the verb. Counterbalancing this factor would be very complicated, as the list of common psych verbs is relatively short.

<sup>7</sup>For Uriagereka (2011), *a picture* in (14.12a) is an underlying subject. Example (14.12a) is therefore a potential English counter-example to the subject island constraint.

## 14 Conclusions on the empirical data

(14.12) (Uriagereka 2011: 95)

- a. Of which politician is there a picture on the wall?
- b. I often think of politicians that there is a picture of them on every wall.

Notice that Uriagereka's argument is not restricted to relative clauses, as example (14.12a) shows. His objection, then, does not hold for our studies, because we used similar materials across experiments, hence with the same potential of having proleptical topics, and nevertheless we found a contrast between relative clauses and interrogatives.

But the original remark in Giorgi & Longobardi concerns specifically relative clauses, and topicalizing constructions like relativization seem indeed more prone to be associated with aboutness proleptics or hanging topics. If so, this could explain the cross-construction difference that we observed in our experiments.

The possibility of analyzing relativization out of an NP as non-extraction has been discussed by Haegeman et al. (2014: 87–88). They argue that the relative phrases are not hanging topics based on the following evidence: (i) the head noun constrains the preposition of the relative phrase, and (ii) the relative phrase is sensitive to island constraints.

In this respect, we agree with Haegeman et al. Hanging topics in relatives are possible in French, though restricted to colloquial French. But they involve a gapless relative clause and are restricted to *que* relatives, hence to NPs.

(14.13) (Abeillé & Godard 2007: 42; attributed to Françoise Gadet)

- Vous avez une figure que vous devez avoir de la température.  
you have a face that you must have.INF of the temperature  
'You have a face that you must have fever.'

The complementizer *dont* cannot be used in such an aboutness relation. It can introduce gapless relative clauses, but must be coindexed with a resumptive pronoun.

(14.14) (Godard 1985: 21–22)

- a. un argument dont<sub>i</sub> on pense que personne ne l<sub>i</sub>' a  
an argument of.which one thinks that noone NEG it has  
utilisé  
used  
'an argument that we think that noone has used it'

- b. \* un argument dont on pense que personne n' a utilisé  
 an argument of.which one thinks that noone NEG has used  
 'an argument that we think that noone has used it'

This condition is not met in our experimental stimuli, in which there is no element that can serve as a resumptive pronoun in the relative. And yet, replacing *dont* by *que* in our relatives decreases the acceptability: it is the way we constructed our “ungrammatical” controls in the experiments on *dont* relative clauses. Even though, as just explained, the construction is only colloquial and not ruled out, these controls received very low acceptability ratings.<sup>8</sup>

The relative phrase *de qui* cannot introduce gapless relatives. Moreover, the head noun of the subject/object of the relative clause selects for the the preposition *de*. Omitting the preposition or replacing it with a different one would be ungrammatical. The ungrammatical controls in our experiments on *de qui* relative clauses were created by omitting the preposition, and these conditions received very low ratings.

I conclude that the relative clauses tested in our experiments (Experiment 1 to 9) are “real” instances of filler-gap dependencies. The relative phrases do not express loose relations, but are constrained by syntactic rules (e.g. argument selection).

## 14.6 A cross-linguistic perspective

As mentioned previously, the results of our experiments on French are compatible with the experiments by Sprouse et al. (2016) on Italian, even though they do not match exactly.

In Abeillé et al. (2020), we reproduced their results on English: there was a significant “island effect” (interaction) disfavoring extraction out of the subject with preposition stranding, both for interrogatives and relative clauses like (14.15).

- (14.15) The dealer sold a sportscar, which [the color of \_] delighted the baseball player because of its surprising luminance.

---

<sup>8</sup>English seems less strict as far as subextraction out of an NP is concerned, as shown by the following examples:

- (i) \* This is the city that I've always wanted to go.  
 (ii) This is the city that I've always wanted to visit the capital. (examples from Chaves & Putnam 2020: 59)

A contrast like the one between (i) and (ii) does not exist in French.

## 14 Conclusions on the empirical data

Our experimental items also contain extractions with the *of* preposition pied-piped, thus in a configuration more similar to French or Italian. In this case, a cross-construction difference emerges in that English does not behave differently than Italian or French. We therefore find a significant “island effect” in interrogatives, but not in relative clauses like (14.16).

- (14.16) The dealer sold a sportscar, of which [the color \_] delighted the baseball player because of its surprising luminance.

This is not surprising, because the cognitive principles responsible for the FBC constraint should be cross-linguistically valid.

The obvious question that arises is: Why did we observe an interaction effect in English relative clauses with preposition stranding? I am not able to give a satisfactory answer, at this time. Many questions remain open about preposition stranding in English that may help us to understand English extractions out of the subject.

There have been some corpus studies comparing the use of preposition stranding vs. pied-piping in English: Johansson & Geisler (1998) on the London-Lund Corpus (spoken British English), the Birmingham Corpus (spoken component), the British National Corpus (spoken component) and the London-Oslo/Bergen Corpus, Trotta (2000) on the Brown University Corpus (written American English), Gries (2002) on the British National Corpus, Hoffmann (2005, 2008, 2011) on the International Corpus of English (British English component) and Hoffmann (2011) on the International Corpus of English (Kenyan English component). Two main contrasts have been reported by many authors. (a) Spoken data contains more preposition stranding than written data (Johansson & Geisler 1998: 70; Gries 2002). Hoffmann (2005: 280–284) attributes this to a distinction in formality. Indeed, Haegeman et al. (2014: 88) claim that pied-piping constructions are “unnatural” in colloquial English. (b) A cross-construction difference is noticeable: there is a preference for preposition stranding in interrogatives, but a preference for pied-piping in (non-free) relative clauses (Johansson & Geisler (1998), Trotta 2000; Hoffmann 2005, 2011).

In the Brown Corpus, Trotta (2000: 57) finds that 63.7% of the interrogatives use preposition stranding instead of pied-piping. Hoffmann (2008) reports much higher proportions, with 96% of direct interrogatives and 92% of indirect interrogatives displaying preposition stranding. Hoffmann (2011: 148 Kenyan English) has similar figures: 81% of direct and 91.7% of indirect interrogatives show preposition stranding. Pied-piping is more present in formal contexts, but the effect of formality is minor (Hoffmann 2011: 152–155; see also Trotta 2000: 64–65).

In relative clauses, pied-piping is only possible with *wh*-words (*that* and null relativizers only allow for preposition stranding) and almost impossible in free relative clauses (Hoffmann 2005, 2008, 2011). However, preposition stranding is not an option in some circumstances: with certain antecedents like *way* or *extent*, or with prepositions like *beyond* or *during* (Johansson & Geisler 1998: 74–76). In the written modality, Trotta (2000) reports that 98.9% of *wh*-relative clauses had pied-piping; in *which* relative clauses, Johansson & Geisler (1998: 70) found 97% and Hoffmann (2005) found 92% of pied piping. In Hoffmann (2008)'s data, 69% of *wh*-relative clauses displayed pied-piping, but this proportion goes up to 91% when only the formal register is considered. Similarly, 86.4% of the relative clauses in Hoffmann's British English data, and 84.1% of the relative clauses in Hoffmann's Kenyan English data have pied-piping (Hoffmann 2011: 148).

Even in spoken data, Johansson & Geisler (1998) report that, depending on the corpus, 69%–86% of *which* relative clauses use pied-piping instead of preposition stranding. The proportion of pied-piping is higher in more formal settings. Here, the classification adopted by the scholars leads to different results. Johansson & Geisler (1998: 71) uses the classifications of their corpora. They report no less than 66% of pied-piping in *which* relative clauses in the category "Leisure-Dialogue" of the BNC. Hoffmann (2011) distinguished three levels of formality. He observes that the proportion of pied-piping increases strongly with the degree of formality. In the "informal" level, barely more than 20% of the *wh*-relative clauses show pied-piping.

Hoffmann (2011: 150) distinguishes relative clauses from clefts. In the other studies, the proportions given above for relative clauses probably include clefts as well. In British English, the distribution is similar in clefts and relative clauses, as 86.0% of the clefts use pied-piping instead of preposition stranding.<sup>9</sup>

Furthermore, all extractions out of NPs studied by Trotta (2000) are instances of pied-piping.<sup>10</sup> In Hoffmann's (2011) data, this proportion is 80.9% (75.6% in British English; 88.9% in Kenyan English). Interestingly, Hoffmann found 17 instances of extraction out of the subject in the British English component and 4 instances in the Kenyan English component, which are not included in his analysis, since "stranding is not an option in these cases" (Hoffmann 2011: 119;fn. 3).

The English relative clauses with preposition stranding tested by Abeillé et al. (2020) employed preposition stranding (i) in a relative clause, (ii) in a written and relatively formal context, and (iii) with extraction out of an NP. As we have

<sup>9</sup>In Kenyan English, we observe a preference for preposition stranding (only 40.0% of the clefts have pied-piping). However, this distribution is based on only 5 occurrences in total.

<sup>10</sup>One occurrence is a question (Trotta 2000: 61), 56 occurrences are relative clauses (Trotta 2000: 184).

just seen, such relative clauses are unlikely to occur in spontaneous production. This may not be sufficient to account for the interaction effect that was found disfavoring extraction out the subject by Abeillé et al., but it still shows that there are more factors at play than a subject/object distinction. As the corpus studies reported in this book show, there is a contrast between configurations in which extraction out of NPs is frequent and configurations in which it is rare: In the former case (e.g., *dont* or *de qu-* relative clauses), extraction out of the subject is the majority, in the latter case (e.g., *avec qu-* relative clauses, interrogatives), it is virtually absent in the corpora. This resembles the pattern that we observe here: extraction out of the subject is acceptable in *which* relative clauses with pied-piping (a frequent configuration for extraction out of NPs) and unacceptable in relative clauses with preposition stranding (in which extraction out of NPs is hardly attested).

Gries (2002) noticed that transitive verbs show a preference for pied-piping compared to other verb types. Since we used transitive verbs, this remark is interesting, but does not explain the contrast between subject and object. Gries thinks that this factor is actually correlated with another one, also significant in predicting the choice of the structure: the syllabic length of the material between the filler and the gap. He observes that the longer the distance, the more often the sentences show pied-piping. This observation conflicts with our results, because the distance between the filler and the gap is shorter in extraction out of the subject than in extraction out of the object. This indicates that the factor that causes the interaction effect in our results and in Sprouse et al.'s (2016) findings must be strong enough to override the attested preference for shorter distances.



## **Part III**

# **Formal analysis**



## 15 General discussion

The main finding of the corpus studies and experiments that I have presented in this book is that there is a cross-construction difference as far as extracting out of the subject is concerned, and that the constraints on locality known as “subject island” since the foundational work of Ross (1967) depend on discourse functions. The empirical data also show that extraction out of the subject depends on the type of subjects: sentential or infinitival subjects are not like NP subjects, and embedded subjects are not like subjects of the matrix clause. This was my motivation for proposing the Focus-Background Conflict constraint in order to account for this cross-construction difference. As I argued in part II, other processing factors are also useful for understanding the data, but the FBC constraint relies on information structure, at the interface between semantics and pragmatics, and is therefore part of the grammar. In this section, I will discuss the FBC constraint in more detail, leaving aside the other processing factors at play for extractions (e.g. surprisal caused by infrequent and complex structures). In the following sections, I will propose a formalisation of the FBC constraint in the framework of HPSG.

The FBC constraint in (4.31), reproduced here in (15.1) for convenience, states the following:

- (15.1) Focus-background conflict (FBC) constraint:  
A focused element should not be part of a backgrounded constituent.

### 15.1 Clarifying the FBC constraint

Intuitively, it seems reasonable to assume that something cannot simultaneously be backgrounded and in the foreground, presupposed and unknown, highlighted and able to be elided. Focus and background come in complementary distribution, and an element is either focused or belongs to the background.

The novelty of the FBC constraint is to state that a constituent cannot be partly focused if it is also backgrounded. Some assumptions are necessary in order to make the constraint work. First, the FBC does not specify what kind of focus is not allowed as part of a backgrounded constituent. So far, my main concern has

been informational focus, because that is the type involved in interrogatives and clefts. However, because focus and background are in complementary distribution, I will assume that all kinds of focus fall under the FBC.

Second, we assume that a constituent is backgrounded if its head is backgrounded. Otherwise relativizing out of an object NP (or any NP) that is part of the focus domain would violate the FBC constraint. In (15.2), the relative clause is restrictive and backgrounded, and thus the NP object of the matrix clause is partly backgrounded and partly focused, but we assume that the direct object is focused, because its head is focused. Hence, (15.2) does not violate the FBC constraint.

(15.2) I can't see [the man [you mentioned yesterday]<sub>BG</sub>]<sub>F</sub>.

Third, I assume with other scholars (a.o. Lahousse 2011, Song 2017) that embedded clauses have an internal information structure, independent of the information structure role the clause itself may play with respect to the matrix clause meaning. In the formalism that I adopt in the following sections, information structure is expressed as a binary relation between a constituent and a clause meaning. For example, a restrictive relative clause is generally considered as backgrounded with respect to the meaning of the clause that embeds it, but this does not mean that its antecedent cannot play the role of a topic with respect to the relative clause itself. In example (15.3), I use a graphical representation of information structure in which the binary relation is represented by an arrow starting from the constituent that bears the information structure role and pointing to the clause (represented by its verb) with respect to which the relation holds.

(15.3)

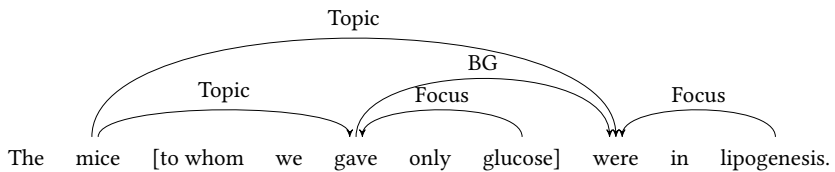

A possible context for (15.3) is that of an experiment in which one group of mice are fed glucose, and the other ones are fed glucose and fat. Given this context, *mice* is at the same time the default topic of the matrix clause (its subject)<sup>1</sup> and the default topic of the relative clause (its antecedent). The relative clause is

<sup>1</sup>In this particular context, it is probably best interpreted as a contrastive topic.

interpreted as a restrictive relative, and is therefore backgrounded with respect to the matrix clause meaning. However, the presence of the focus particle *only* signals that *glucose* bears a focus. The focused element [*only glucose*] is hence “part of” the backgrounded relative clause, but this does not violate the FBC constraint, because the former is focused with respect to the embedded clause meaning and the latter is backgrounded with respect to the matrix clause meaning. By contrast, (15.4) does violate the FBC constraint, because [*which car*] is focus with respect to the matrix clause meaning, and [*the driver of (the car)*] is topic with respect to the same clause meaning. The former is therefore both topic and focus of the clause meaning at the same time.

(15.4)

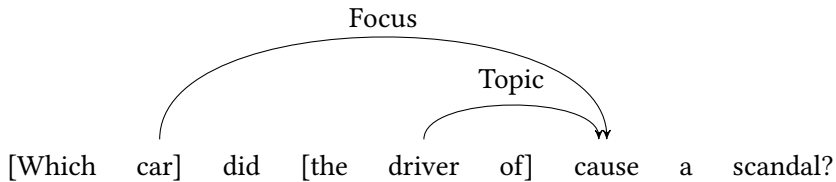

Fourth, S or VP are considered constituents only with respect to the clause that embeds them.<sup>2</sup> The FBC constraint does not apply to their internal structure. In example (15.5b), the V is backgrounded, but this does not mean that the NP object cannot be focus. Thus the VP is not backgrounded, even though its head is.

- (15.5) a. A: What did David read?  
 b. B: [David read]<sub>Bg</sub> [this book]<sub>F</sub>.

Similarly, the subject or an adverb can be the focus of the clause meaning even when the verb is backgrounded. On the other hand, if the meaning of the embedded clause is backgrounded with respect to the matrix clause meaning, as in (15.3), all elements in the embedded clause are backgrounded with respect to the matrix clause meaning.<sup>3</sup>

<sup>2</sup>Here and in the following, I am distinguishing between an S (or CP) like [*David read the book*] and a VP like [*read the book*].

<sup>3</sup>Relative clauses belong to the syntactic island defined by Ross (1967) as “Complex NP Constraint”.

(i) (Ross 1967: 119)

\* The man [who<sub>i</sub> I read a statement [which<sub>j</sub> <sub>-j</sub> was about <sub>-i</sub>]] is sick.

Goldberg (2013) argues that extracting out of relative clauses is ruled out because relative

Finally, an important aspect of the FBC constraint is that it assumes a gradience of discourse status: “The more focused an element, the more focused the constituent it is part of” (Abeillé et al. 2020: 21). The gradient nature of information structure is assumed by many scholars. Kuno (1987) defines focus as the “highly unpredictable” information in the sentence; since information can be more or less predictable, it follows that focalization is graded. Webelhuth (2007: 310–311) defines a “more thematic than” relation that holds between different arguments, such that some are topics (themes) to a greater or lesser degree than the others. Ambridge & Goldberg (2008: 369) assume that a constituent can be more or less backgrounded, and that this is the factor that explains the gradient acceptability of extractions out of backgrounded constituents.

## 15.2 The FBC in long-distance dependencies

In Section 14.2, I discussed the results of focalization out of backgrounded constructions in long-distance dependencies. In (15.6), the extraction gives rise to focalization of the *wh*-phrase. More precisely: The *wh*-phrase is focused with respect to the matrix clause meaning.

---

clauses are backgrounded (according to the BCI constraint, see Section 4.2.3). The FBC constraint predicts that focalization out of a relative clause should lead to a discourse clash, but it does not constrain relativizations (topicalization) out of a relative clause.

This seems at odds with examples like (i), but research on extraction out of relative clauses shows that acceptability increases drastically if the words in the matrix clause are semantically weakly defined, i.e. with indefinite antecedents (Kluender 1998) and main verbs almost devoid of meaning (Chaves & Putnam 2020: 91–92). Furthermore, Erteschik-Shir & Lappin (1979) have shown that extraction out of presentational relative clauses is acceptable. Notice that most of the time, the examples given in this literature are relativizations out of a relative clause.

Furthermore, there are languages that allow some extractions out of a relative clause (with or without resumptive pronouns, see Crysmann (2012) for a discussion and analysis). Example (ii) is an extraction out of a relative clause in Hausa, showing relativization.

(ii) (Tuller 1986: 84 cited by Crysmann 2012: 55)

?gà m̄atar [d̄a<sub>i</sub> ka b̄a ni littāfin [d̄a<sub>j</sub> m̄alāmai sukà san  
 here.is woman REL 2SG.MAS.CPL give me book REL teachers 3.PL.CPL know  
 m̄utūm̄in [d̄a<sub>k</sub> -<sub>i</sub> ta rub̄ut̄a w̄a -<sub>k</sub> -<sub>j</sub>]].

man REL 3.SG.FEM.CPL write for

‘Here is the woman that you gave me the book that the teachers know the man (she) wrote (it) for (him).’

This evidence challenges the idea that extraction out of relative clauses is altogether unacceptable. Therefore, the fact that relativizing out of a relative clause does not violate the FBC constraint makes correct predictions. But it still remains to be demonstrated that there is a cross-construction difference between relativizations and interrogatives.



## 15 General discussion

extraction out of the subject and extraction out of the object (i.e. the slope of the red line is significantly different from 0). However, we cannot tell whether the interaction effect would also appear with another grammatical baseline or is artificially produced by the subject relative clause preference.

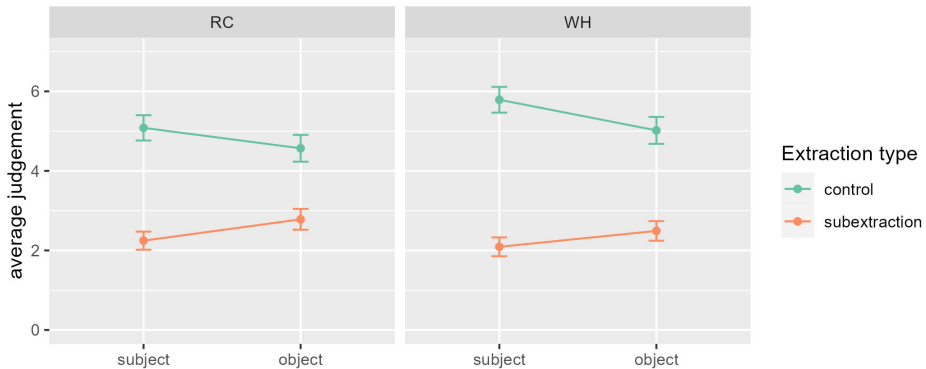

Figure 15.1: Interaction plot of Sprouse et al.'s (2016) experiments on subject island in English

I conclude that there is enough evidence concerning long-distance dependencies to affirm that the focused element is focus also with respect to the meaning of the embedded clauses. There is certainly a persistent tendency for long-distance *wh*-questions pointing to this, and it is also supported by the intuitions of many scholars. But further research is needed.

### 15.3 The puzzle of *it*-clefts

In this section, I will concentrate on *it*-clefts (or *c'est*-clefts for French) with narrow focus, i.e. with focus on the pivot. As explained in Section 12.1, all-focus *c'est*-clefts are possible and common in French (Lambrecht 1994, Doetjes et al. 2004), but they differ in prosody (Doetjes et al. 2004: 541–549) and therefore should be analyzed differently.

#### 15.3.1 The information structure of the *that*-clause

The information structure of the pivot was discussed previously in Section 12.1, but we have not considered the information structure of the *that*-clause (or *que*-clause in French). The approach that seems to predominate in the literature is



Prince's (1978). Prince describes the content of the *that*-clause in English *it*-clefts as being presupposed and containing "known", but not necessarily "given" information (her terminology). Actually, in some variants of *it*-clefts "frequent in historical naratives", the speaker assumes the information to be unknown to the hearer (hence not given in discourse) but known in general terms as an indisputable (for example historical) fact. One example is given in (15.7).

(15.7) (Prince 1978: 900)

It was in this year that Yekuno Amlak, a local chieftain in the Amba-Sel area, acceded to the so-called Solomonic Throne.

In the other and most common variant of *it*-clefts, the information is presupposed to be known by both speaker and hearer, thus the information in the *that*-clause does not play an important role in the development of the discourse. Sometimes this information may even be given. For this reason, this part may easily be omitted in most of the cases, as shown in (15.8).

(15.8) (Prince 1978: 897)

Who made this mold? Was it the teachers?

That the *that*-clause is presupposed (and therefore backgrounded) can be shown using the negation test: whereas (15.9a) and (15.9b) convey the same information, the negation in (15.9d) only targets the pivot, whereas John having lost something remains true. This is not the case in (15.9c), where the scope of the negation is ambiguous.

(15.9) a. John lost his keys.

b. It was his keys that John lost.

c. John didn't lose his keys.

d. (Prince 1978: 884)

It wasn't his keys that John lost.

The proposition expressed by the *that*-clause in (15.9b), namely that *John lost x*, is still true in (15.9d). What is negated is identity *x* with the entity *his keys*. This seems to indicate that the content of the *that*-clause is backgrounded.

There are, however, alternative views. According to Gussenhoven (2007: 96), the *that*-clause in *it*-clefts can contain reactivated information, i.e. old information that bears focus. This would be incompatible with the idea that everything in the *that*-clause is backgrounded. Song (2017) concludes that there is not enough evidence for considering *that*-clauses in *it*-clefts as backgrounded and decides not to constrain their information structure in his own analysis.



15.3.3 Other extractions out of the *that*-clause

We may add that *wh*-questions with extraction out of the *que*-clause in French seem relatively acceptable:

- (15.13) [De qui]<sub>i</sub> est - ce que [c' est toi]<sub>j</sub> qui -<sub>j</sub> dois tenir [la main -<sub>i</sub>]]?  
 of who is it that it is you who must hold the hand  
 'Of whom are you the one who must hold the hand?'

In example (15.13), the object complement *de qui* is necessarily focus, since it is the *wh*-element of the *wh*-question. It is also part of the *que*-clause of the embedded *c'est*-cleft, and therefore backgrounded according to Prince (1978).

Yet, it would be necessary to confirm this intuition with empirical data, because it has been claimed that such examples are ungrammatical. For example, Godard (1988) says that extraction out of the *que*-clause in general – e.g. (15.14) – is only possible with a resumptive pronoun.

- (15.14) (Godard 1988: 44)  
 \* Les enfants, [qu]<sub>i</sub>' il était convenu que [c' était le père de Paul  
 the children that it was agreed that it was the father of Paul  
 qui -<sub>j</sub> devait raccompagner -<sub>i</sub>]], ont décidé de rentrer  
 who must.PAST take.back have decided of come.back  
 seuls.  
 alone  
 'The children, that it was agreed that it was Paul's father who was  
 supposed to bring (them) back, have decided to come back on their  
 own.'

If Godard's intuition concerning (15.14) was true, then this case would challenge the FBC constraint, because relativization should be acceptable regardless of the discourse status of the *que*-clause. But examples with a similar structure and unquestionable focalization of the pivot such as (15.15) can be found online.<sup>7</sup> Hence more work is needed in order to resolve this issue.

- (15.15) des périodes de crise prolongées[,] [[d]ont]<sub>i</sub> [c' est toujours l'  
 DET times of crisis protracted of.which it is always the  
 économie et le social qui -<sub>j</sub> pâtissent -<sub>i</sub>]]  
 economy and the social who suffer  
 'times of long-term crisis, from which it's always the economy and  
 the social affairs that suffer' (i.e. the economy and the social affairs  
 suffer from times of long-term crisis)

<sup>7</sup>Example (15.15) from [https://www.lorientlejour.com/article/699098/Un\\_systeme\\_tampon,\\_en\\_attendant\\_un\\_nouveau\\_pacte\\_constitutionnel.html](https://www.lorientlejour.com/article/699098/Un_systeme_tampon,_en_attendant_un_nouveau_pacte_constitutionnel.html), last access 19/06/2023

Examples like (15.13) and (15.15) seem to indicate either that the FBC constraint is incorrect, or that we have to abandon the assumption that the *que*-clause is backgrounded in French.

#### 15.3.4 Assumptions in this book

In an experiment to be published elsewhere (Winckel et al. in preparation), we have tested sentences like (15.9d), which serves as the basis for the assumption that the content of the *that*-clause is presupposed. The empirical evidence suggests that the elements in the *that*-clause are not backgrounded to the same degree. I will therefore follow Song (2017) and assume in my analysis that the elements in the *que*-clause may have any discourse status. This also allows me to not take into account the distinction between all-focus and narrow-focus *it*-clefts or *c'est*-clefts. However, an empirically grounded investigation of the information structure of *it*-clefts would be very beneficial to our understanding of focalization.

## 16 A French HPSG fragment

In this work I adopt the HPSG framework, based mostly on the general principles laid out in Pollard & Sag (1994), and updated more recently in Müller, Abeillé, Borsley & Koenig (2021). This framework allows for a precise formal representation of all aspects of linguistic utterances (morphology, syntax, semantics and information structure) and provides a construction-based approach to extraction constructions (Sag 1997, 2010, Ginzburg & Sag 2000). There is already considerable work on French in HPSG, which allowed me to build on a large body of detailed analyses for French syntax and semantics.<sup>1</sup> Abeillé (2007) gives an overview of an HPSG grammar for French which I partially adopt here, though with a binary branching approach.<sup>2</sup> The formalism that I adopt for semantics is the Minimal Recursion Semantics (MRS, Copestake et al. 2005) and the formalism for the information structure is based on Song's (2017) proposal.

---

<sup>1</sup>I.e. Miller & Sag (1997) and Abeillé & Godard (2002) on clitics and auxiliaries, Abeillé et al. (2004) and Abeillé, Bonami, et al. (2006) on *de* and *à* prepositions, Sag & Godard (1994) and Godard & Sag (1996) on dependents of nouns, Abeillé & Godard (2003) and Abeillé, Borsley & Espinal (2006) for extraction out of specifiers (with degree adverbs and comparative correlatives, respectively), Abeillé & Godard (1997) and Kim & Sag (2002) on negation, as well as Abeillé et al. (2008) and Marandin (2011) on information structure in French.

<sup>2</sup>HPSG implementations, such as the CoreGram Project (Müller 2015) and the DELPH-IN (DEep Linguistic Processing with HPSG) consortium (<http://www.delph-in.net>) use binary branching. However, many HPSG accounts do not, including several I use as the basis of my own analysis here (a.o. Sag 1997, Ginzburg & Sag 2000). Traditionally, researchers working on French in HPSG assume a flat structure (a.o., Abeillé & Godard 2002 for tense auxiliaries), but this has recently faced some criticism by Aguila-Multner & Crysmann (2020) who argue in favor of a binary analysis of VPs in French in order to better account for modification and coordination. I consider that the debate about the appropriate branching in French is still an open one, and choose binary branching as a default that would allow straightforward implementation (e.g. the French fragment of the CoreGram project). On the other hand, this choice has, to my knowledge, no major implication for my analysis, especially because I only consider headed structures. A conversion of the present analysis into flat structures is possible: Instead of applying to the object in the non-head daughters, the rules would merely have to apply to all objects in the list of non-head daughters.

## 16.1 General principles of an HPSG grammar

In HPSG, linguistic entities are modeled by feature structures that are described by feature descriptions (or attribute-value matrices, AVMs). Feature structures are of a certain type, and this type defines which features the sign has and what type of values its features have. Types are ordered in a type hierarchy and every type inherits the properties of its supertype. Values are themselves of a certain type, which is also contained in the type hierarchy of the grammar. A value is either a feature-value description if it is complex, or an atomic value.

A simplified hierarchy of French signs is given in Figure 16.1, from Ginzburg & Sag (2000: 19). For example, the subtype *word* inherits the characteristics from the type *lexical-sign* (e.g. having a feature ARG-ST, see below).

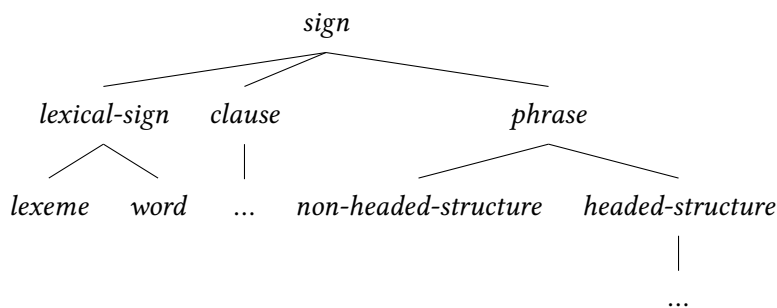

Figure 16.1: Type hierarchy of *sign*

The lexicon of a given language consists of lexical items. Lexical entries are signs of type *lexeme*. Words are derived from these lexemes through lexical rules (unitary branching structures). Phrases are derived through schemata. Not only lexical entries, but also constraints and lexical rules are formalized using AVMs. Constraints define the characteristics of the different types and the conditions the linguistic objects have to satisfy in order to be valid in the given language. Lexical rules define how a lexical item licenses another lexical item.

A sign has at least two main features: PHONOLOGY (PHON) and SYNTAX-SEMANTICS (SYNSEM). The value of PHON is a list of phonemes.<sup>3</sup> The value of SYNSEM is a feature structure of type *synsem*.

<sup>3</sup>For the sake of simplicity, I will follow common practice in HPSG and give as value of the feature PHON the orthographic representation of the sign, not its phonetic transcription. Some researchers encode more information under PHON than its mere phonetic transcription. PHON may for example contain information about accents and prosody (Engdahl & Vallduví 1996: 11, De Kuthy 2002: 166, Bonami & Delais-Roussarie 2006, Bildhauer 2008: Chapter 3). Even though prosody plays an important role in information structure, I have little to say about it with respect to the topic of this work. For this reason, I assume a minimal structure for PHON.

(16.1) Definition of *sign*:

$$\left[ \begin{array}{l} \textit{sign} \\ \text{PHON} \quad \textit{list of phonemes} \\ \text{SYNSEM} \quad \textit{synsem} \end{array} \right]$$

From the syntactic point of view, in the present work I will mostly consider headed structures, i.e. structures in which the mother node structure-shares its *pos* value with one of its daughters. An example of a non-headed structure is coordination (at least in most of the recent HPSG analyses, see Abeillé & Chaves 2020). Signs of the type *headed-structure* have as additional features HEAD-DAUGHTER (HEAD-DTR) and NON-HEAD-DAUGHTERS (NHEAD-DTRS).<sup>4</sup> The feature HEAD-DTR contains the AVM of type *sign* of the head. The feature NHEAD-DTRS contains a list of feature structures of the type *sign*. For example, in a headed structure, and assuming a binary analysis, this list constrains only one element, i.e. the non-head element (specifier, complement, modifier or filler).

(16.2) Head Feature Principle from Pollard & Sag (1994: 34):

$$\textit{headed-structure} \Rightarrow \left[ \begin{array}{l} \text{SYNSEM|LOC|CAT|HEAD} \quad \boxed{1} \\ \text{HEAD-DTR} \quad \left[ \text{SYNSEM|LOC|CAT|HEAD} \quad \boxed{1} \right] \end{array} \right]$$

$$\left[ \begin{array}{l} \textit{synsem} \\ \text{LOC} \quad \left[ \begin{array}{l} \textit{loc} \\ \text{CAT} \quad \textit{cat} \\ \text{CONT} \quad \textit{cont} \end{array} \right] \\ \text{NONLOC} \quad \textit{nonloc} \end{array} \right]$$

Figure 16.2: Definition of *synsem* and *loc*

The feature SYNSEM encodes every piece of information concerning syntax and semantics, see Figure 16.2. Features that concern local dependencies are encoded under the feature LOCAL (LOC), in an AVM of type *loc*. Features that concern non-local dependencies are encoded under NONLOCAL (NONLOC), in an AVM of type *nonloc*. I describe the feature NONLOC in Section 16.2, where I present the details of an HPSG analysis of extractions. Under LOC, the features related to semantics (but also pragmatics, as we will see) are encoded under the feature CONTENT (CONT). The feature CATEGORY (CAT) contains the features related to (local) syntax.<sup>5</sup>

<sup>4</sup>I adopt the terminology from Sag (1997). Other HPSG accounts may use another terminology (e.g., DAUGHTERS in Ginzburg & Sag 2000: Section 2.5).

<sup>5</sup>Most HPSG versions assume a third local feature CONTEXT (a.o. Pollard & Sag 1994: 16–21), where information related to the pragmatics of the sign is encoded. The features of *context* objects are for example C-INDICES (e.g. who is the addressor, who is the addressee) and BACKGROUND (related to what is usually called Common Ground, see Chapter 4). In my fragment of French, pragmatics is part of CONTENT, as assumed by Song (2016, 2017).

I will now define how syntax and semantics work on the local level. This includes the encoding of information structure, which is part of *CONTENT* in my formalization. In Section 16.2, I will then turn to non-local dependencies.

### 16.1.1 Syntax

The value of *CAT* is an AVM of the type *cat*. It contains a feature *HEAD*, whose value is an AVM of the type *part-of-speech* (*pos*). The fragment developed in this book uses seven parts of speech: *noun*, *verb*, *determiner* (*det*), *adjective* (*adj*), *adverb* (*adv*), *preposition* (*prep*) and *complementizer* (*comp*). The hierarchy of *pos* is given in Figure 16.3. The structure of *HEAD* varies depending on the part of speech. For example, verbs have a verb form (*VFORM*), while other parts of speech do not.

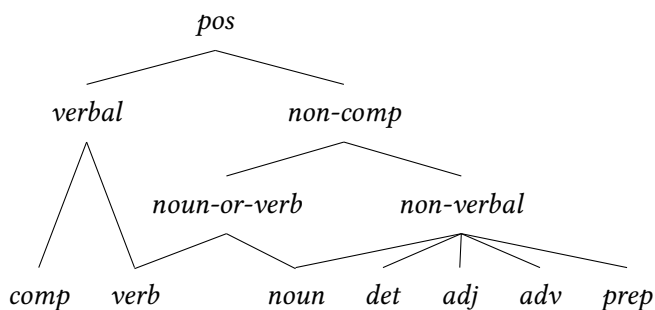

Figure 16.3: Type hierarchy of *pos*

Arguments can be realized or non-realized (e.g. *I cooked./I cooked lasagne.*). In French, realized arguments or adjuncts can be realized as XPs (e.g. NPs, PPs) or as clitics. Following Miller & Sag (1997), Abeillé & Godard (2002) and Aguila-Multner & Crysmann (2020), I assume that pronominal clitics in a non-subject function are affixes that attach to the verb. Lastly, arguments and adjuncts may be realized non-locally: this is what I have called “extraction” throughout this book. All these possibilities give rise to different subtypes of *synsem*, i.e. *canonical*, *pro* (non-realized), *affix* (realized as clitic) and *gap* (non-locally realized). I adopt the hierarchy in Figure 16.4, adapted from Abeillé et al. (1998) and already presented in Winckel & Abeillé (2020: 104).

#### 16.1.1.1 Valence

Signs of the type *word* have a main feature *ARG-ST* that has as value a list of *synsem*. This list is traditionally the list of the different arguments dependent on



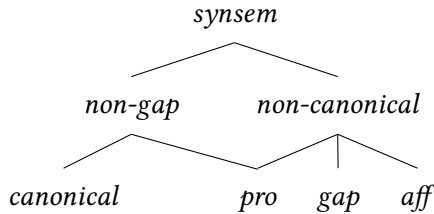

Figure 16.4: Type hierarchy of *synsem*

the lexeme. In addition, the word selects its canonically realized complements ( $[SYNSEM\ canonical]$ ) via the feature *COMPS*, its subject via the feature *SUBJ* and its specifier via the feature *SPR*. This is captured in the Argument Realization Principle, see Figure 16.6. Non-realized arguments ( $[SYNSEM\ pro]$ ) are present in *ARG-ST*, and can for example serve as semantic arguments, while no syntactic information is needed about them on the phrasal level. Clitic arguments ( $[SYNSEM\ aff]$ ) are realized morphologically through lexical rules, as just stated. Gaps ( $[SYNSEM\ gap]$ ) are realized through lexical rules and non-local dependencies; this will be explained in Section 16.2.

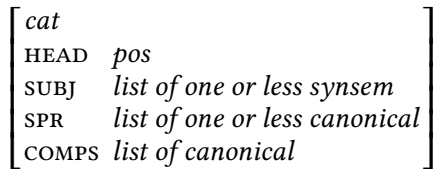

Figure 16.5: Definition of *cat*

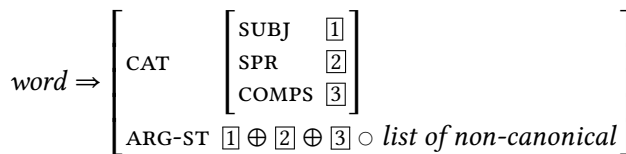

Figure 16.6: Argument Realization Principle (adapted from Ginzburg & Sag 2000: 171)

The value of *COMPS* is a list of *synsem* objects (only canonical ones), which is a sublist of the *ARG-ST* list. The value of *SPR* is a list of *canonical* objects as well, but this list contains at most one element. Subjects need to be in *SUBJ* even if they are extracted, in order to account for the so-called *que-qui* rule in French, see below. The value of *SUBJ* is a list of *synsem* objects with one or no element. Figure 16.5 summarizes how *cat* is defined.

The example in Figure 16.7 illustrates how verbs state their arguments using the transitive verb *enthousiasme* ('inspires') from example (16.3), where both subject and direct object are realized canonically.

- (16.3) L' originalité de l' innovation enthousiasme mes collègues.  
 the uniqueness of the innovation excites my colleagues  
 'The uniqueness of the innovation excites my colleagues.'

word									
PHON	$\langle \textit{enthousiasme} \rangle$								
SYNSEM LOC CAT	<table style="border-collapse: collapse; margin-left: 20px;"> <tr> <td style="border-right: 1px solid black; padding: 2px 5px;">HEAD</td> <td style="padding: 2px 5px;"><i>verb</i></td> </tr> <tr> <td style="border-right: 1px solid black; padding: 2px 5px;">SUBJ</td> <td style="padding: 2px 5px;"><math>\langle \underline{1} [\text{LOC CAT HEAD } \textit{noun}] \rangle</math></td> </tr> <tr> <td style="border-right: 1px solid black; padding: 2px 5px;">SPR</td> <td style="padding: 2px 5px;"><math>\langle \rangle</math></td> </tr> <tr> <td style="border-right: 1px solid black; padding: 2px 5px;">COMPS</td> <td style="padding: 2px 5px;"><math>\langle \underline{2} [\text{LOC CAT HEAD } \textit{noun}] \rangle</math></td> </tr> </table>	HEAD	<i>verb</i>	SUBJ	$\langle \underline{1} [\text{LOC CAT HEAD } \textit{noun}] \rangle$	SPR	$\langle \rangle$	COMPS	$\langle \underline{2} [\text{LOC CAT HEAD } \textit{noun}] \rangle$
HEAD	<i>verb</i>								
SUBJ	$\langle \underline{1} [\text{LOC CAT HEAD } \textit{noun}] \rangle$								
SPR	$\langle \rangle$								
COMPS	$\langle \underline{2} [\text{LOC CAT HEAD } \textit{noun}] \rangle$								
ARG-ST	$\langle \underline{1}, \underline{2} \rangle$								

Figure 16.7: *enthousiasme* ('inspires') in (16.3)

### 16.1.1.2 Syntactic composition

After the selection mechanism, I will now present the mechanism in charge of the syntactic composition. For this, I assume the type hierarchy for *headed-structure* presented in Figure 16.8, which enhances Figure 16.1.

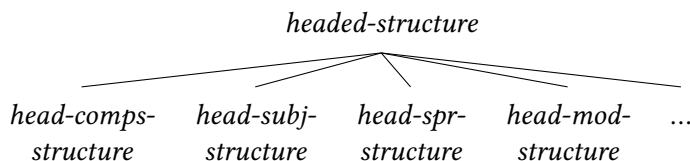

Figure 16.8: Type hierarchy of *headed-structure* (incomplete)

Ginzburg & Sag (2000: 33) a.o. define a Generalized Head Feature Principle (GHFP): by default, a headed-phrase's SYNSEM features are the SYNSEM features of its head daughter.<sup>6</sup> This alternative analysis accounts, for example, for the fact that by default valence features remain unchanged from head daughter to mother.

<sup>6</sup>The Head Feature Principle (16.2) already specifies that a headed phrase's HEAD features are the HEAD features of its head daughter. Unlike the GHFP however, the Head Feature Principle is not a default principle.

- (16.4) Generalized Head Feature Principle (GHFP, adapted from Ginzburg & Sag 2000: 33)

$$\textit{headed-structure} \Rightarrow \left[ \begin{array}{l} \text{SYNSEM} \quad / \boxed{1} \\ \text{HEAD-DTR} \quad [ \text{SYNSEM} \quad / \boxed{1} ] \end{array} \right]$$

We define a default value (represented with the sign /) as follows: the default value (as well as all values that are subsumed by it) can only be overwritten by more specific subtypes (Lascarides & Copestake 1999: 85). For the GHFP in (16.4), this means that the values of all SYNSEM features are by default the values of the SYNSEM features of the head daughter, except if they are overwritten by some definition of subtypes of *headed-structure*. This is the case for the definitions of *head-comps-structure*, *head-subj-structure*, *head-spr-structure* and *head-mod-structure*. I will now define each of these subtypes.

In structures that are not a combination of a head with one of its complements, the GHFP (16.4) guarantees that the value of the feature COMPS remains constant from daughter to mother. Structures that combine a head with one of its complements are of the type *head-comps-structure*, defined in (16.5). The value of the complement is “subtracted” from the COMPS list of the daughter.<sup>7</sup> Because French complements appear in free order, the “subtracted” element can be situated anywhere in the list (hence the shuffle  $\circ$  symbol). The AVM in Figure 16.9 illustrates the case where *enthousiasme* combines with the NP *mes collègues* in (16.3).

$$(16.5) \quad \textit{head-comps-structure} \Rightarrow \left[ \begin{array}{l} \text{COMPS} \quad \boxed{1} \\ \text{HEAD-DTR} \quad [ \text{COMPS} \quad \boxed{1} \circ \langle \boxed{2} \rangle ] \\ \text{NHEAD-DTRS} \quad \langle [ \text{SYNSEM} \quad \boxed{2} ] \rangle \end{array} \right]$$

Notice that in (16.5) and Figure 16.9 I am using shortcuts in my nomenclature: e.g. HEAD stands for SYNSEM|LOC|CAT|HEAD, NP stands for a linguistics object with all the characteristics of an NP (HEAD value is *noun*, empty COMPS and SPR lists). I will use this kind of shortcut throughout Part III.

The mechanism is the same when the head combines with its subject. The sign is then of the type *head-subj-structure* (16.6) and the value of the subject is “subtracted” from the SUBJ list of the head, leaving an empty SUBJ list for the mother. For all other headed structures the value of SUBJ remains constant from head-daughter to mother, as stated by the GHFP (16.4). This is illustrated in Figure 16.10 where the verb of (16.3) combines with its subject.

<sup>7</sup>Analyses not assuming binary branching do not need to use *head-comps-structure* recursively until the COMPS list is empty, since all complements can be listed in NHEAD-DTRS. As mentioned above, a non-binary analysis would not affect the central aspects of my analysis.

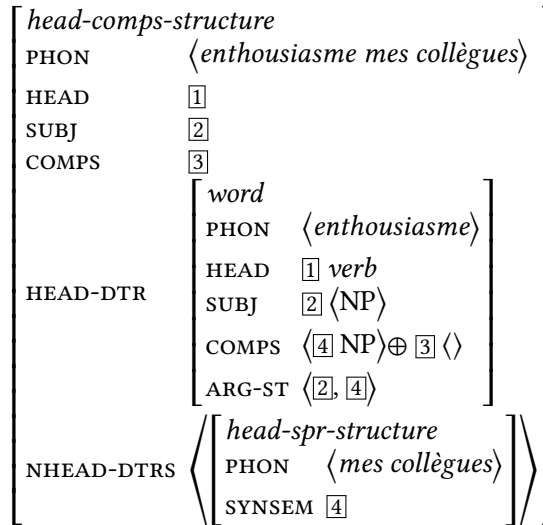

Figure 16.9: Illustration of a *head-comps-structure*, following example (16.3)

$$(16.6) \quad \textit{head-subj-structure} \Rightarrow \left[ \begin{array}{l} \text{SUBJ} \quad \langle \rangle \\ \text{HEAD-DTR} \quad \left[ \text{SUBJ} \quad \langle \boxed{1} \rangle \right] \\ \text{NHEAD-DTRS} \quad \langle \left[ \text{SYNSEM} \quad \boxed{1} \right] \rangle \end{array} \right]$$

*head-spr-structure* (16.7) defines the combination of the head with its specifier and follows the same mechanism, while the definition of the GHFP (16.4) states that the value of *SPR* is identical from head daughters to mother for the other headed structures.

$$(16.7) \quad \textit{head-spr-structure} \Rightarrow \left[ \begin{array}{l} \text{SPR} \quad \langle \rangle \\ \text{HEAD-DTR} \quad \left[ \text{SPR} \quad \langle \boxed{1} \rangle \right] \\ \text{NHEAD-DTRS} \quad \langle \left[ \text{SYNSEM} \quad \boxed{1} \right] \rangle \end{array} \right]$$

A complete syntactic analysis for (16.3) can be seen in Figure 16.11.

Adjuncts select the element they modify through a head feature *MOD* defined for adjectives, adverbs, and verbs. The value of *MOD* is an AVM of type *none-or-synsem*, a supertype of *synsem* (see Figure 16.4) and of *none* (whenever the linguistic object is not an adjunct). The head and its adjunct combine via the *head-mod-structure*. The element selected by the modifier can have an empty or a non-empty *COMPS* list (it is underspecified in this respect). Consequently, modifiers may appear either after (empty *COMPS*) or before (non-empty *COMPS* list) the complements of the element they modify. This is illustrated by (16.8) for adjectives and (16.9) for adverbs.

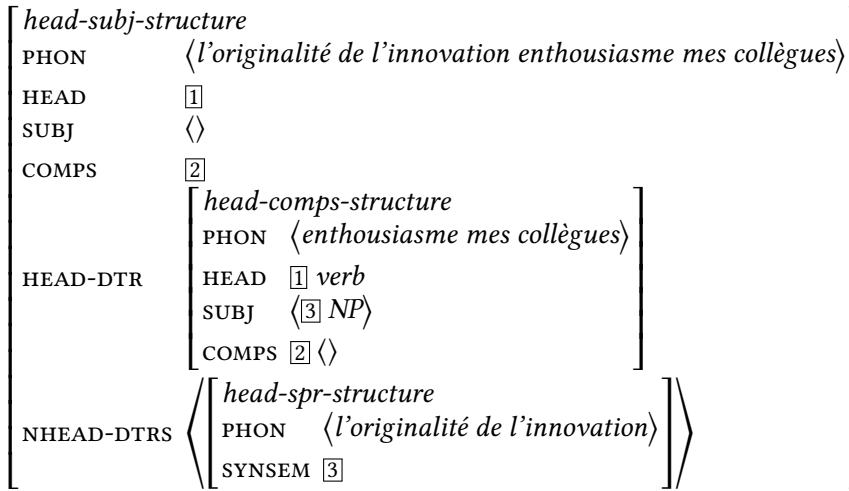

Figure 16.10: Illustration of a *head-subj-structure*, following example (16.3)

- (16.8) a. un livre sur les indiens intéressant  
a book on the Indians interesting  
‘a book about Indians interesting’  
b. un livre intéressant sur les indiens  
a book interesting on the Indians  
‘an interesting book about Indians’
- (16.9) a. Ils sont enthousiastes souvent.  
they are thrilled often  
‘They are often thrilled.’  
b. Ils sont souvent enthousiastes.  
they are often thrilled  
‘They are often thrilled.’

Figure 16.12 shows the combination of a noun and an adjective.

- (16.10) [l' [innovation formidable]<sub>N'</sub>]<sub>NP</sub>  
the innovation amazing  
‘the amazing innovation’

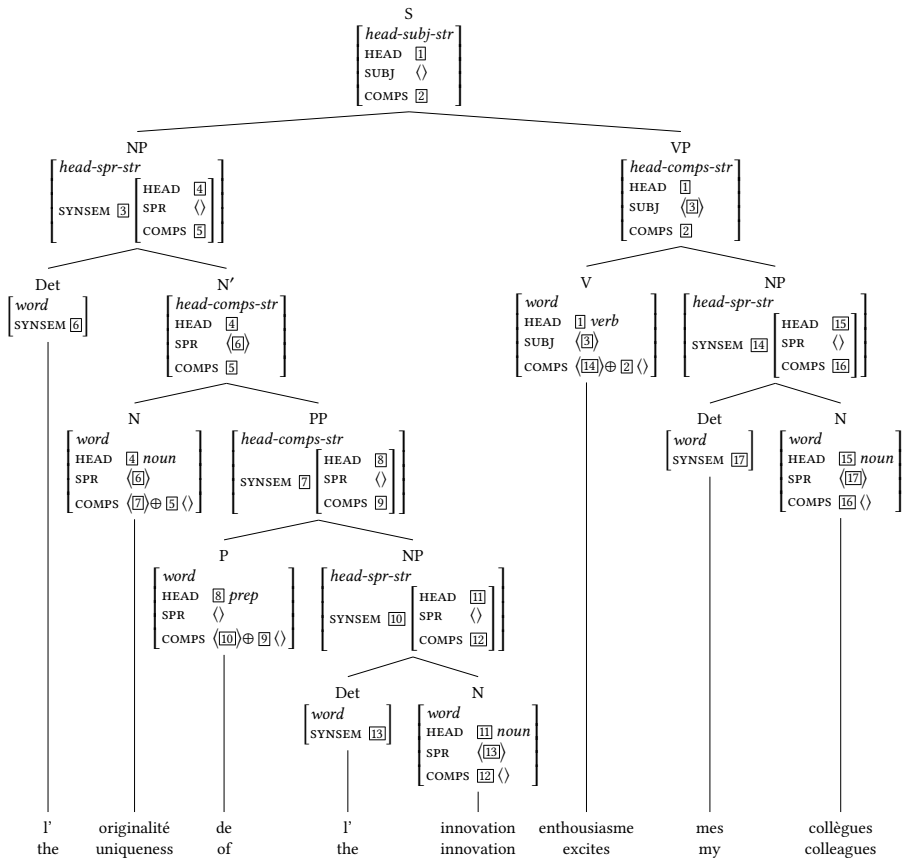

Figure 16.11: Syntactic representation for “L’originalité de l’innovation enthousiasme mes collègues.” (‘The uniqueness of the innovation excites my colleagues.’)



on semantic factors. The analysis of adverbs follows roughly the same principles. Relative clauses are always [WEIGHT *nonlite*], i.e. postnominal (Abeillé & Godard 1999a: 343). I will come back to the analysis of relative clauses in Section 16.2.

The different linearization rules are summarized in (16.11).

(16.11) Linearizations rules:

- a. *head-spr-structure*  $\Rightarrow$  NHEAD-DTR < HEAD-DTR
- b. *head-comps-structure*  $\Rightarrow$  HEAD-DTR < NHEAD-DTR
- c. *head-subj-structure*  $\Rightarrow$  HEAD-DTR [INV +] < NHEAD-DTRS
- d. *head-subj-structure*  $\Rightarrow$  NHEAD-DTR < HEAD-DTR [INV -]
- e. *head-mod-structure*  $\Rightarrow$  NHEAD-DTR [WEIGHT *lite*] < HEAD-DTR
- f. *head-mod-structure*  $\Rightarrow$  HEAD-DTR < NHEAD-DTR [WEIGHT *nonlite*]

### 16.1.2 Semantics

I adopt the Minimal Recursion Semantics (MRS) semantic representation as developed by Copestake et al. (2005). This representation is often used in HPSG implementations, e.g. the CoreGram Project (Müller 2015). Semantics is represented in an AVM of type *mrs*. Copestake et al. (2005) define three features for the *mrs* objects: HOOK, RELATIONS (RELS) and HANDLE-CONSTRAINTS (HCONS).<sup>8</sup> Song (2017) adds an additional feature to encode information about the discourse status of the different parts in an utterance: ICONS.

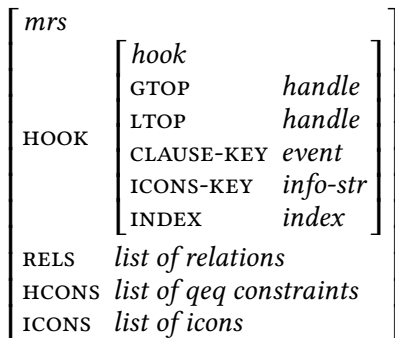

Figure 16.13: Definition of *mrs*

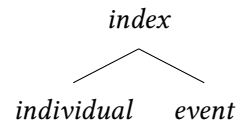

Figure 16.14: Type hierarchy of *index*

<sup>8</sup>Copestake et al. (2005) define the value of RELS and HCONS as a “bag” rather than a list, but they represent them as lists.



In this section, I describe how MRS works, leaving the ICONS features aside. In section 16.1.3 dedicated to information structure in HPSG, I will come back to ICONS and the way information structure is encoded in my fragment of French.

The reference marking feature INDEX, embedded under CONT|HOOK in MRS, can also be found in other semantic representations in HPSG (see Pollard & Sag 1994: 24–26). The value of INDEX is an AVM of type *index* that has different subtypes in accordance with the type of referent concerned (individual or event).

Each lexeme with a semantic content introduces an “Elementary Predication” (EP) in the discourse. In the MRS representation, this is reflected by the fact that every lexeme has (at least) one object of type *relation* in its RELS list. Conventionally, the nomenclature for the different types of relations is *lexeme\_rel*. For example, the lexical entry for *collègue* (‘colleague’) contains in its RELS list an object of type *colleague\_rel*. The handle is the label of the EP. It is encoded under a feature LBL with a value of type *handle* (conventionally labeled *h1*, *h2*, *h3*, etc.). The first argument of an EP is a variable (conventionally labeled *i*, *j*, *k*, etc. for individuals and *e1*, *e2*, *e3*, etc. for events), and is encoded under a feature ARG0 with a value of type *index*. On the level of the lexeme, the value of ARG0 is coindexed with the value of INDEX. The other arguments, if any, are handles, which are encoded under features ARG1, ARG2, etc. with values of type *index*.<sup>9</sup> Copestake et al. (2005) also define other possible features (e.g. RESTR, BODY) for scopal relations, which we do not need in this fragment.

The (simplified) semantic representation for *collègue* (‘colleague’) is given in Figure 16.15. Being a noun, *collègue* has an INDEX of type *individual*. Because *collègue* is a relational noun, *colleague\_rel* has a feature ARG1. In ARG-ST, the value of ARG1 is identified with the index of the complement.

The value of the feature HANDLE-CONSTRAINTS (HCONS) is a list of AVMs of the type *equality modulo quantifiers (eqq)*. They link the arguments with each other, especially for scope resolution. It is not absolutely necessary to take it into account for my analysis, so I will leave aside the feature HCONS in this work.

The feature HOOK has a value of type *hook* that contains five features: GTOP, LTOP, CLAUSE-KEY, ICONS-KEY and INDEX. CLAUSE-KEY is related to information structure and I will describe it in the next section. GTOP states the global top handle: this is the EP in the sentence whose ARG0 value is not bound by any other EP. LTOP states the local top handle, i.e. the EP of the head in headed structures. On the level of the lexeme, the value of LTOP is identified with the value of the LBL, see Figure 16.15.

<sup>9</sup>The order of the arguments follows the obliqueness of the arguments (Keenan & Comrie 1977): less oblique < more oblique (Copestake et al. 2005: 287).

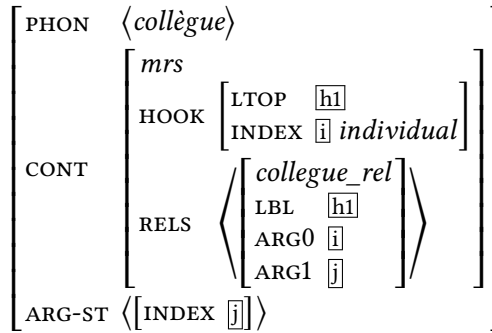

Figure 16.15: Lexical entry for *collègue* ('colleague') – semantics

In headed structures, the value of *GTOP* is the same for the mother and its daughters. The mother inherits the value of the whole *HOOK* of the head daughter.

In structures with simple semantic composition, the value of the *RELS* list of the mother is a concatenation of the lists of the daughters. In some structures however, the semantic contribution of the structure is more than the sum of the contributions of the daughters. Therefore, phrases have an additional *loc* feature *c-CONT* in which the contribution of the structure can be encoded. Like *CONT*, *c-CONT* takes as value an *mrs* object. The value of the *CONT|RELS* (and *HCONS*) list of the mother is an amalgamation of the lists of both daughters and of its own *c-CONT|RELS* (and *HCONS*) list in structures with simple semantic composition. Headed structures are thus defined as in Figure 16.16.

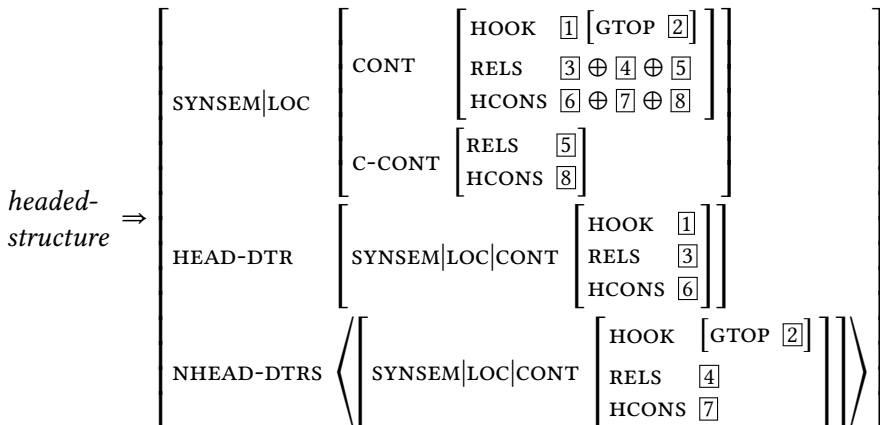

Figure 16.16: Semantic composition

A sentence is well-formed if all *index* variables are bound, except for one. For the sake of simplicity, I assume that the *handle* corresponding to this unbound variable is then unified with the value of *GTOP*. At the sentence level, the value of *GTOP* must be equal to the value of *LTOP*.

*CLAUSE-KEY* is a feature introduced by Song (2017). Its value is structure-shared with the *INDEX* value of the semantic head of the clause (usually the main verb). Only finite clauses are considered “clauses” for *CLAUSE-KEY*. For example, in (16.12), the value of *CLAUSE-KEY* is *e2* for *Sherry wants Minnie to bring her dog* and all its subtrees, because *bring* is non-finite.

- (16.12) [Maria wonders<sub>e1</sub> [why Sherry wants<sub>e2</sub> Minnie to bring<sub>e3</sub> her dog],  
[whereas Erica is<sub>e4</sub> allergic to them]].

The lexical entry for a verb constrains the NPs and non-finite VPs in its *ARG-ST* list to structure-share the value of their *CLAUSE-KEY* feature with the value of its own *CLAUSE-KEY*. This ensures that all elements in a clause share the same *CLAUSE-KEY* value – except the finite sentential arguments, as I will explain in Section 16.2.5.<sup>10</sup> On the clausal level, a constraint ensures that the *CLAUSE-KEY* value of the clause is structure-shared with the *INDEX* value of the semantic head of the clause. Below I will describe the different clause types and the way the constraint is formalized.

Figure 16.17 gives a concrete example of how MRS’s representation of semantics works for a whole sentence. I do not elaborate on the semantics of quantifiers, developed at length by Copestake et al. (2005), since they are not central to the topic of this book. Suffice it to say that I assume the distinction between definite articles (with a relation *def\_rel*), indefinite articles (with a relation *indef\_rel*) and possessives (with a relation *poss\_rel*).

### 16.1.3 Information structure

The issue of an adequate representation of information structure in HPSG has not been settled yet, and before I present the representation I adopted in this work, I briefly discuss the other proposals in the literature. Song (2017) seems best suited for my aims, and I chose his proposal despite some minor problems and open questions that I leave for future work to resolve.

---

<sup>10</sup>The mechanism is somewhat more sophisticated in Song (2017), but this should not affect the analysis.



## 16.1.3.1 Different representations of information structure in HPSG

As yet, there is no broad consensus on the way information structure should be represented and implemented in HPSG. The different proposals make different choices relative to: (i) how many and what discourse statuses they assume, (ii) on which level they encode information structure (e.g. main feature of *sign*, *CONTENT* feature), (iii) what type of object is taken as value by the feature expressing discourse status (e.g. *sign*, *mrs*) and (iv) whether or not they allow for embedded clauses to have their own internal information structure. See Bildhauer (2008: 113–122) and De Kuthy (2021) for an overview of the HPSG literature on information structure.

The first solid attempt to develop an information structure representation was made by Engdahl & Vallduví (1996), based on Vallduví’s (1992) theory of information structure. Instead of the double binary distinction Topic/Comment and Focus/Background that was presented in Section 4.1, Vallduví’s (1992) analysis relies on a binary distinction Focus/Background, in which the latter entails a binary distinction Link/Tail. The concept of Link is roughly equivalent to what I defined as Topic, and the concept of Tail applies to the elements in the utterance that are neither Link (Topic) nor Focus. Engdahl & Vallduví (1996) represent information structure under *CONTEXT*. They propose a *CONTEXT* feature *INFO-STRUC* that has as value an AVM with three features: *LINK*, *FOCUS* and *TAIL* (Engdahl & Vallduví 1996: 11). They all take as value an object of type *sign* even though Engdahl assumes a value of type *content* in her later accounts (Engdahl 1999). In addition, Engdahl & Vallduví account for the interface between prosody and information structure, but I leave this aspect of their analysis aside.

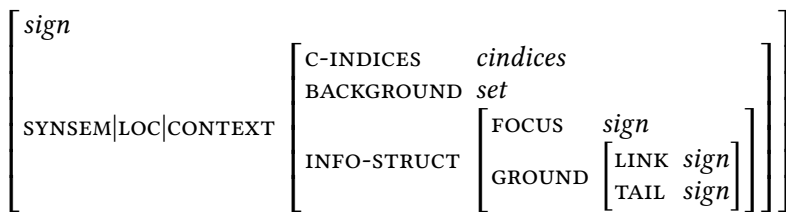

Figure 16.18: Encoding of information structure in Engdahl & Vallduví (1996: 11), adapted to a modern representation

De Kuthy (2002) makes a different proposal: she encodes information structure under a main feature of *sign* *INFO-STRUC*, which takes as value a feature structure of type *info-struc* with only two features: *FOCUS* and *TOPIC* (De Kuthy 2002: 161–165). Each of these features has as value a list of *meaningful expression* objects (a semantic representation proposed by Richter (2000) that is closer to

Montague Semantics (Dowty et al. 1981) than MRS). There is therefore no encoding of backgroundedness, even though it would be relatively easy to introduce it in her model if needed. Having a list as value enables her analysis to distinguish utterances with multiple foci or topics from utterances with one focus or topic. De Kuthy accounts for the interface between prosody and information structure along the same lines as Engdahl & Vallduví (1996).

$$\left[ \begin{array}{l} \textit{sign} \\ \text{PHON} \quad \textit{list} \\ \text{SYNSEM} \quad \textit{synsem} \\ \text{INFO-STRUC} \quad \left[ \begin{array}{l} \textit{info-struc} \\ \text{FOCUS} \quad \textit{list of meaningful expressions} \\ \text{TOPIC} \quad \textit{list of meaningful expressions} \end{array} \right] \end{array} \right]$$

Figure 16.19: Encoding of information structure in De Kuthy (2002: 161–165) (summary)

Bildhauer’s (2008) proposal is relatively similar to De Kuthy (2002). Information structure is encoded under the feature IS, a main feature of *sign* that takes as value an AVM object with the two features FOCUS and TOPIC. The value of these two features is a list of lists of EPs (i.e. of objects of the type *relation* as defined in MRS, see above). Here again, backgroundedness is not explicitly encoded, but it remains relatively easy to identify.<sup>11</sup> Having as value a list of lists enables the analysis to identify multiple foci or topics, similarly to De Kuthy. Bildhauer also develops a very elaborate representation of accents and tonality that can be mapped onto the information structure.

$$\left[ \begin{array}{l} \textit{sign} \\ \text{PHON} \quad \textit{list} \\ \text{SYNSEM} \quad \textit{synsem} \\ \text{IS} \quad \left[ \begin{array}{l} \text{FOC} \quad \textit{list} \\ \text{TOPIC} \quad \textit{list} \end{array} \right] \end{array} \right]$$

Figure 16.20: Encoding of information structure in Bildhauer (2008: 147)

$$\left[ \begin{array}{l} \textit{sign} \\ \text{LOC} \quad \textit{local} \\ \text{NONLOC} \quad \textit{nonloc} \\ \text{SYNSEM} \quad \left[ \begin{array}{l} \text{IS} \quad \left[ \begin{array}{l} \textit{is} \\ \text{TOPIC} \quad \textit{list} \\ \text{FOCUS} \quad \textit{list} \end{array} \right] \end{array} \right] \end{array} \right]$$

Figure 16.21: Encoding of information structure in Bildhauer & Cook (2010: 74)

<sup>11</sup>As pointed out by Bildhauer, “it will correspond to those EPs that are present on the RELS list, but absent from the FOC and TOPIC list” (Bildhauer 2008: 147). My definition of background would rather correspond to the EPs that are present on the RELS list, but absent from the FOC list.

Bildhauer & Cook (2010) and Müller, Bildhauer & Cook (2020) use a slightly different variant of Bildhauer’s (2008) proposal, where the feature *is* is a feature in *synsem*.

Webelhuth’s (2007) proposal differs in many respects from other proposals in the literature. He represents information structure under *CONTENT*. The value of *CONTENT* is an AVM of type *content* with two features, *BACKGROUND* (*BG*) and *FOCUS* (*FOC*). The value of *FOCUS* is a list of *meaningful expression* objects (Richter 2000). The value of *BG* is an AVM with two features: *FOCUS VARIABLES* (*FVARS*) which takes a list of variables (based on Krifka (1992) in order to account for multiple foci or topics); and *CORE*, which takes an object of the type *meaningful expression* and encodes the meaning of the sign. Furthermore, Webelhuth (2007: 310) makes a distinction between Focus/Topic/Background, which are mapped to prosody; and Theme, which is mapped to syntax. His concept of Theme is similar to what I defined as “aboutness topic”, with an important aspect of gradience (one constituent being more or less thematic than another one). Thematicity is encoded in a meaningful expression.

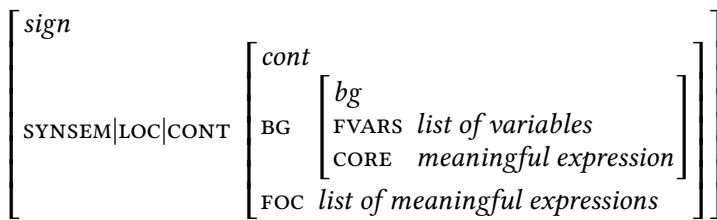

Figure 16.22: Encoding of information structure in Webelhuth (2007: 312)

Song (2017) encodes information structure inside *mrs* objects, thus under *CONTENT*, with a feature called *ICONS*. The mechanism of *ICONS* mimics the mechanism of *RELS*. The value is a list of objects of type *info-struct*, and each word that introduces an EP also introduces such an object. The type hierarchy of *info-struct* is fine-grained and contains subtypes like *focus*, *topic* and *bg* (background). *info-struct* objects have two features, *TARGET* and *CLAUSE*, that make it possible to map the semantic variable bearing the discourse function to the clause with respect to which it has this discourse function. Embedded clauses can then have their own internal information structure independently of the main clause (e.g. a relative clause may be backgrounded with respect to the meaning of the main clause, but have its own topic or focus domain). I present Song’s (2017) proposal in more detail below.

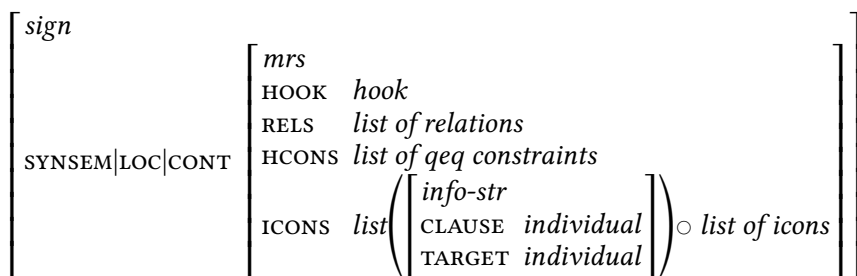

Figure 16.23: Encoding of information structure in Song (2017: 116) (simplified)

### 16.1.3.2 Desiderata for a representation of information structure

As shown by the variety of proposals, there is disagreement on many points, but especially on where the features for information structure should be embedded. Some define them at the level of the *sign* (De Kuthy 2002, Bildhauer 2008), however, Müller, Bildhauer & Cook (2020: 145) point out that discourse status must be accessible in *synsem* objects because some elements, like focus particles (e.g. *only*), are sensitive to information structure, and must be able to select via the valence features an element with the appropriate information structure. De Kuthy (2002: 160–161) argues that INFO-STRUC should not be part of a *local* object, otherwise this has undesirable consequences for focus projection in her analysis. Focus projection is a property of the interface between prosody and information structure: the word(s) bearing the main stress in the sentence may project this focus status to domains wider than where the stress falls. Focus projection is therefore the reason why the German sentence in (16.13) can have an all-focus reading (e.g. as an answer to the question *What happened?*), while the main stress is on *Auto*.

(16.13) all-focus reading (De Kuthy 2002: 160)

Hans hat ein AUTO gewonnen.

Hans has a car won

‘Hans won a car.’

If the word that receives the main stress appears in the prefield (before the finite verb), focus projection is blocked: (16.14) cannot have an all-focus reading.

(16.14) all-focus reading (De Kuthy 2002: 160)

# Ein AUTO hat Hans *t* gewonnen.

a car has Hans won

‘Hans won a car.’



But De Kuthy analyses the prefield position as a filler-gap dependency with a trace (*t*) at the canonical position in the middlefield, and traces as empty categories that structure-share their *loc* value with their filler. This is the reason why De Kuthy argues against encoding information structure in *loc* objects: otherwise, the information structure of (16.13) is indistinguishable from the information structure of (16.14), and the difference in available readings between the two sentences remains unexplained.

For the formalization of the FBC constraint, however, it is crucial that the focus interpretation received by the extracted element be structure-shared with the noun that subcategorizes for this element. Hence, contra De Kuthy (2002), I argue that information structure has to be encoded in *loc* objects. I avoid the problem pointed out by De Kuthy (2002) because I adopt a traceless account of extraction along the lines of Bouma et al. (2001).<sup>12</sup> Traceless analyses have been supported by Sag & Fodor (1994, 1996) on grounds, among others, that they are more compatible with an incremental processing model (Pickering & Barry 1991, Tanenhaus et al. 2000).<sup>13</sup>

Different accounts use different terminologies with respect to information structure, and this is especially true for “background”, which may or may not include the topic, depending on the model. In Engdahl & Vallduví’s (1996) analysis, LINK (Topic) is included in (BACK)GROUND, whereas for De Kuthy (2002), Bildhauer (2008) and Song (2017), Background, Topic and Focus are in complementary distribution, i.e. Background is what is neither Topic nor Focus. The FBC constraint in (15.1) presupposes direct access to a list of the focused elements on the one hand, and to the “backgrounded” (i.e. non-focus) ones on the other hand. This is possible in all accounts that I have mentioned, though more straightforwardly so in Engdahl & Vallduví’s (1996) model and in Song’s (2017) model (which defines a supertype *non-focus* for *background* and *topic*).

However, Song’s (2017) proposal is the only one that offers the possibility to model different layers of information structure for each clause in an utterance, thanks to the pair of features CLAUSE/TARGET. This means that any element in an embedded clause can be presupposed with respect to the main clause (e.g. if the whole clause is backgrounded, as in restrictive relative clauses) and still be the topic with respect to the embedded clause (e.g. the extracted element in a

---

<sup>12</sup>De Kuthy (2002) refers to it as a possible way to avoid focus projection in (16.14), but says that it is otherwise incompatible with her own analysis of German.

<sup>13</sup>On the other hand, traceless analyses may also have some drawbacks: as explained by Müller (2016: 570–574), more rules have to be added to the grammar, and especially the German V2 position seems to be hard to analyze without the use of a trace.

relative clause<sup>14</sup>). This advantage is fundamental for my purposes, and the main reason for choosing his model.

For consistency, I follow Song’s (2017) representation whenever possible, even though it has some weaknesses. For example, this model does not distinguish between a clause with multiple foci or topics and one with a single focus or topic (an aspect addressed by De Kuthy (2002), Webelhuth (2007), Bildhauer (2008), and Müller, Bildhauer & Cook (2020)). It is beyond the scope of this work to define a new and more optimal representation of information structure in HPSG that incorporates all relevant aspects. In general, I am also confident that my analysis is compatible with any well thought-out representation of information structure.

### 16.1.3.3 The representation of information structure adopted in this work

In this work, information structure is encoded under the *mrs* feature INDIVIDUAL CONSTRAINTS (ICONS). The definition of *mrs* presented in Figure 16.13 is reproduced in Figure 16.24.

<i>mrs</i>													
HOOK	<table style="border-collapse: collapse;"> <tr> <td style="border-right: 1px solid black; padding: 2px 5px;"><i>hook</i></td> <td style="padding: 2px 5px;"></td> </tr> <tr> <td style="border-right: 1px solid black; padding: 2px 5px;">GTOP</td> <td style="padding: 2px 5px;"><i>handle</i></td> </tr> <tr> <td style="border-right: 1px solid black; padding: 2px 5px;">LTOP</td> <td style="padding: 2px 5px;"><i>handle</i></td> </tr> <tr> <td style="border-right: 1px solid black; padding: 2px 5px;">CLAUSE-KEY</td> <td style="padding: 2px 5px;"><i>event</i></td> </tr> <tr> <td style="border-right: 1px solid black; padding: 2px 5px;">ICONS-KEY</td> <td style="padding: 2px 5px;"><i>info-str-or-none</i></td> </tr> <tr> <td style="border-right: 1px solid black; padding: 2px 5px;">INDEX</td> <td style="padding: 2px 5px;"><i>index</i></td> </tr> </table>	<i>hook</i>		GTOP	<i>handle</i>	LTOP	<i>handle</i>	CLAUSE-KEY	<i>event</i>	ICONS-KEY	<i>info-str-or-none</i>	INDEX	<i>index</i>
<i>hook</i>													
GTOP	<i>handle</i>												
LTOP	<i>handle</i>												
CLAUSE-KEY	<i>event</i>												
ICONS-KEY	<i>info-str-or-none</i>												
INDEX	<i>index</i>												
RELS	<i>list of relations</i>												
HCONS	<i>list of qeq constraints</i>												
ICONS	<i>list of icons</i>												

Figure 16.24: Definition of *mrs*

The feature ICONS “incorporate[s] discourse-related phenomena into semantic representations of sentences” (Song 2016: 31).<sup>15</sup> The feature CONT thus encodes not only the semantics but also the pragmatics of the sign. This is the reason why Song (2016, 2017) does not define any CONTEXT feature for *local* objects.

The value of ICONS is a list of *icons* objects. All ICONS objects express a binary relation between *index* variables. For example, they express anaphora resolution

<sup>14</sup>On the basis of the pervasive parallelism between topicalization and relativization, I proposed that in Japanese what is relativized is the theme of the relative clause.” (Kuno 1987: 15)

<sup>15</sup>Song & Bender (2012) credit Dan Flickinger and Ann Copestake with first suggesting the ICONS feature.

either as an identity relation (“eq”) or a non-identity relation (“neq”) between two variables.

- (16.15) (Song 2016: 31)
- a. John<sub>i</sub> likes himself<sub>j</sub>. [*i eq j*]
  - b. John<sub>i</sub> likes him<sub>j</sub>. [*i neq j*]

Honorific relations are also encoded by means of *icons* object, namely *rank* objects, as a binary relation between the addressor and the addressee. Information structure is encoded in *info-str* objects, in accordance with the hierarchy of *icons* objects in Figure 16.25, adapted from Song (2016: 36, 2017: 114).

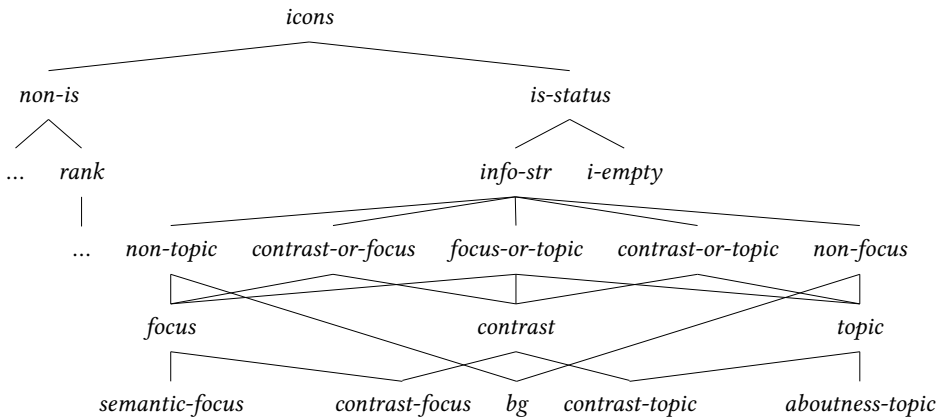

Figure 16.25: Type hierarchy of *icons*

Objects of the type *info-str* express a binary relation between a clause (an *event* variable) and some element in the sentence (through its *index* variable). Accordingly, they have two features, *CLAUSE* and *TARGET*. Every word that introduces an EP in the semantic representation also introduces an *info-str* object.<sup>16</sup> The value of *TARGET* is structure-shared with the value of the *INDEX* of the word. The value

<sup>16</sup>The corollary of this rule is that semantically empty words like expletives or copulas do not introduce any *info-str* object. Song (2017: 112) also assumes that syncategorematic items, e.g. relative pronouns, are “informatively empty” and do not introduce any *info-str* objects. He does not explain in detail how such words are analyzed in his model, and especially what the value of *ICONS-KEY* is. I add the possibility of a value *i-empty* to his hierarchy of *icons*, and assume that semantically and informatively empty words are [*ICONS-KEY i-empty*]. This is not very elegant because all *icons* objects are supposed to introduce a binary relation. Furthermore, an unfortunate consequence is that the *ICONS* list of a sign may contain *i-empty* elements. This could probably be avoided, but I leave the task of resolving this challenge for future work.

of *CLAUSE* is structure-shared with the value of *CLAUSE-KEY*, which itself is the current clause’s event variable.

(16.16) Definition of *info-str*:

$$\left[ \begin{array}{l} \textit{info-str} \\ \text{CLAUSE } \textit{event} \\ \text{TARGET } \textit{index} \end{array} \right]$$

Figure 16.26 illustrates how words in the lexicon introduce an underspecified object of type *info-str*. Figure 16.27 is the AVM for *collègues* (‘colleagues’) in (16.17) where the direct object bears the informational focus of the utterance.

(16.17) [L’ originalité de l’ innovation]<sub>T</sub> enthousiasme [mes collègues]<sub>F</sub>.  
 the uniqueness of the innovation excites my colleagues  
 ‘The uniqueness of the innovation excites my colleagues.’

$$\left[ \begin{array}{l} \text{PHON} \\ \text{CONT|HOOK} \end{array} \left[ \begin{array}{l} \langle \textit{collègue} \rangle \\ \text{INDEX } \boxed{\textit{i}} \textit{ individual} \\ \text{CLAUSE-KEY } \boxed{\textit{e}} \textit{ event} \\ \text{ICONS-KEY } \left[ \begin{array}{l} \textit{info-str} \\ \text{CLAUSE } \boxed{\textit{e}} \\ \text{TARGET } \boxed{\textit{i}} \end{array} \right] \end{array} \right] \right]$$

Figure 16.26: Lexical entry for *collègue* (‘colleague’) – information structure

$$\left[ \begin{array}{l} \text{PHON} \\ \text{CONT|HOOK} \end{array} \left[ \begin{array}{l} \langle \textit{collègues} \rangle \\ \text{INDEX } \boxed{\textit{i}} \textit{ individual} \\ \text{CLAUSE-KEY } \boxed{\textit{e}} \textit{ event} \\ \text{ICONS-KEY } \left[ \begin{array}{l} \textit{semantic-focus} \\ \text{CLAUSE } \boxed{\textit{e}} \\ \text{TARGET } \boxed{\textit{i}} \end{array} \right] \end{array} \right] \right]$$

Figure 16.27: Lexical entry for *collègue* (‘colleague’) in example (16.17) – focussed

The feature *ICONS-KEY* encodes the “main” information structure of the head. The other *icons* objects (the information structure for the rest of the phrase, or other pragmatic relations) are part of the *ICONS* list. There can be only one object for each *TARGET-CLAUSE* pair in the *ICONS* list, i.e. an element may have different discourse statuses for different clauses but not different discourse statuses for one single clause.

- (16.18) Discourse-clash Avoidance Principle:  
 The ICONS list can contain only one *info-str* element for each  
 TARGET-CLAUSE pair.

As long as the word is the head of the structure, the values of ICONS-KEY and CLAUSE-KEY remain the same, as they are part of HOOK. In a headed structure, the ICONS-KEY of the non-head daughter is incorporated into the ICONS list of the mother node. The mother node also inherits the ICONS lists of its daughters and its own C-CONT.<sup>17</sup>

$$\textit{headed-structure} \rightarrow \left[ \begin{array}{l} \text{CONT|ICONS } \boxed{1} \oplus \langle \boxed{2} \rangle \oplus \boxed{3} \oplus \boxed{4} \\ \text{C-CONT } \left[ \text{ICONS } \boxed{4} \right] \\ \text{HEAD-DTR } \left[ \text{CONT|ICONS } \boxed{1} \right] \\ \text{NHEAD-DTRS } \left\langle \left[ \text{CONT } \left[ \begin{array}{l} \text{HOOK|ICONS-KEY } \boxed{2} \\ \text{ICONS } \boxed{3} \end{array} \right] \right] \right\rangle \end{array} \right]$$

Figure 16.28: ICONS Accumulation

## 16.2 Extraction in HPSG

The *synsem* feature NONLOC encodes features that are used for non-local dependencies. I take as a starting point the definition of NONLOC adopted in Borsley & Crysmann (2021). They follow a lexicalist approach to extractions and long-distance dependencies – strongly inspired by Bouma et al. (2001) and Ginzburg & Sag (2000) – in which (i) no empty categories are needed; and (ii) constructions involving non-local dependencies receive different analyses via different non-local features. Sag (2010) provides a detailed overview of the different extractions in English and shows that they are heterogeneous. With that in mind, I propose a way to account for the different extraction constructions discussed in this work: relative clauses (based on the analysis of Abeillé & Godard (2007)), interrogatives and *c'est*-clefts (based on the analysis of Winkel & Abeillé (2020)). My goal is to show how syntax and information structure interact in these constructions.

<sup>17</sup>Song (2017) uses some mechanisms of the LKB grammars (e.g. difference lists) to formulate his constraint. I am using a more traditional approach and thus translate Song's idea into the constraint in (16.28).

## 16.2.1 A traceless analysis

Objects of the type *nonloc* have three features, SLASH, REL and QUE. They all take as value a set: a set of *loc* objects for SLASH, a set of *index* objects for REL and a set of *relations* (EPs) objects for QUE. A non-empty SLASH set denotes the presence of a “missing” element, i.e. an object of type *gap*. HPSG analyses generally assume a set value for the SLASH feature (instead of a list), because this allows two gaps to combine into a single gap (Pollard & Moshier 1990). This property accounts for cases like (16.19), where two gaps are linked to the same filler.<sup>18</sup>

(16.19) [Which document]<sub>i</sub> did you sign <sub>-i</sub> [without reading <sub>-i</sub>]?

Cases like (16.19) are challenging under a movement-based approach, which is why these accounts treat one of the gaps as “parasitic” (see Section 2.4.2 for a discussion of parasitic gaps and arguments against them).

(16.20) Definition of *nonloc*:

$$\left[ \begin{array}{ll} \textit{nonloc} & \\ \text{SLASH} & \textit{set of loc} \\ \text{REL} & \textit{set of index} \\ \text{QUE} & \textit{set of relations} \end{array} \right]$$

In Section 16.1.1 I described the way arguments in the ARG-ST list are selected for canonical or non-canonical realization, based on the type hierarchy of *synsem* in Figure 16.4. Dependents of the type *gap* are defined as follows:<sup>19</sup>

(16.21) Definition of *gap*:

$$\left[ \begin{array}{ll} \textit{gap} & \\ \text{LOC} & \boxed{1} \\ \text{NONLOC|SLASH} & \{\boxed{1}\} \end{array} \right]$$

<sup>18</sup>Chaves & Putnam (2020) propose that the value of SLASH (GAP in their terminology) is a list. Instead of the SLASH Amalgamation Principle (16.22) below, they assume a function of list joining (Chaves & Putnam 2020: 248). Their proposal has the advantage of licensing not only cases like (16.19), but also cases in which two gaps combine into a single gap while keeping distinct indices, as in (i): while in (16.19) the document signed is the same as the document read, in (i) what is eaten can hardly be the same as what is drunk.

(i) What<sub>i+j</sub> do you think [Ed ate <sub>-i</sub> and drank <sub>-j</sub> at the party]? (Chaves & Putnam 2020: 246)

For the sake of simplicity, I adopt the analysis of extractions in Borsley & Crysmann (2021), which is sophisticated enough to formalize the FBC constraint. But my analysis is also compatible with Chaves & Putnam’s proposal.

<sup>19</sup>The original definition is in Pollard & Sag (1994: 160).

A word “gathers” the elements of its arguments’ SLASH set into its own SLASH set. Because *gap* objects have a non-empty SLASH set, their LOC value is also stored in the SLASH set of the word that subcategorized for them. If the NP argument of a verb is realized canonically but has an element in its SLASH set, as is the case in subextractions from subjects or objects, this gap element recursively ends up in the SLASH set of the verb.

(16.22) SLASH Amalgamation Principle adapted from Ginzburg & Sag (2000: 169)

$$word \rightarrow \left[ \begin{array}{l} \text{SLASH} \ / \langle \underline{1} \cup \dots \cup \underline{n} \rangle \\ \text{ARG-ST} \ \langle [ \text{SLASH} \ / \underline{1} ] \dots [ \text{SLASH} \ / \underline{n} ] \rangle \end{array} \right]$$

This SLASH Amalgamation Principle is a default constraint. Some kinds of words, like the copula in *c’est*-clefts (see below) or adjectives that allow so-called “*tough* constructions” (Pollard & Sag 1994, Ginzburg & Sag 2000), select a complement with a non-empty SLASH set and do not contain the slashed element in their own SLASH list.

The same mechanism applies to the other NONLOC features REL and QUE. The SLASH Amalgamation Principle (16.22) can therefore have as a corollary a (default) QUE Amalgamation Principle and a (default) REL Amalgamation Principle. Alternatively, we may adopt the general NONLOC Amalgamation Principle in (16.23).

(16.23) NONLOC Amalgamation Principle

For every NONLOC feature F:

$$word \rightarrow \left[ \begin{array}{l} F \ / \langle \underline{1} \cup \dots \cup \underline{n} \rangle \\ \text{ARG-ST} \ \langle [ F \ / \underline{1} ], \dots, [ F \ / \underline{n} ] \rangle \end{array} \right]$$

The Argument Realization Principle (16.6) and the NONLOC Amalgamation Principle (16.23) are sufficient to account for non-local dependencies in this work, which only deals with the extraction of arguments in headed structures. Specific requirements would be necessary to account for extractions of adjuncts, out of adjuncts and out of non-headed structures.<sup>20</sup> I leave this question open.

Let us go through the argument realization in a prototypical sentence in a bottom-up fashion: The COMPS list of the verb is first worked off as the verb combines with its complement(s) through *head-comps-structure*; then the SUBJ list

<sup>20</sup>For adjuncts, some HPSG analyses posit a supplementary valence feature in CAT which appends the elements of ARG-ST and the modifiers (e.g. the feature DEPS in Bouma et al. 2001). Others assume that extracted modifiers are also part of the ARG-ST list (similar to the proposal in Abeillé & Godard 1997: 17), and extraction of or out of adjuncts is treated using the same rules as in extraction of and out of arguments. Yet others such as Przepiórkowski (2016) cast doubt on the relevance of the argument/adjunct distinction and see “argumenthood” as a continuum.

is worked off as the verb combines with its subject through *head-subj-structure*; and finally, the SLASH set of the verb is worked off as the verb combines with the filler(s) through *head-filler-structure*. Figure 16.29 shows the type hierarchy in Figure 16.8 completed with *head-filler-structure*.

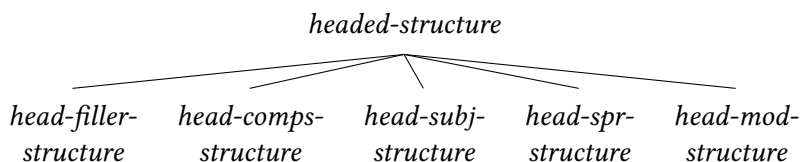

Figure 16.29: Type hierarchy of *headed-structure*

The formal definition of linguistic objects of the type *head-filler-structure* is given in Figure 16.30. They have a non-head daughter with a LOC value that is structure-shared with one element of the head daughter's SLASH set. This same element is missing from the mother node's SLASH set. The type *head-filler-structure* is used to account for interrogatives and relative clauses with a relative pronoun, but *c'est*-clefts and relative clauses with a complementizer are analyzed differently, as I will show below.

$$\text{head-filler-structure} \rightarrow \left[ \begin{array}{l} \text{SLASH} \quad \boxed{1} \\ \text{HEAD-DTR} \quad \left[ \begin{array}{l} \textit{phrase} \\ \text{SLASH} \{ \boxed{2} \} \cup \boxed{1} \end{array} \right] \\ \text{NHEAD-DTRS} \quad \langle \text{LOCAL } \boxed{2} \rangle \end{array} \right]$$

Figure 16.30: Definition of *head-filler-structure*

The GHFP (16.4) guarantees that the mother inherits the SLASH-set from the head daughter in the other headed structures. Consequently, all heads along an extraction path have the property [SLASH *non-empty set*]. Extraction path effects are indeed attested cross-linguistically: there are phonological or morphosyntactic alternations depending on this factor, one form being used outside the extraction path, another one along the extraction path (Zaenen 1983, Hukari & Levine 1995; Bouma et al. 2001: Section 3.2).

Figure 16.31 is the representation of the *wh*-question (16.24), in which the direct object undergoes simple extraction.

- (16.24) Qui l' innovation enthousiasme-t-elle?  
 who the innovation[F] excites-0-3SG.F.SBJ  
 'Who does the innovation excite?'



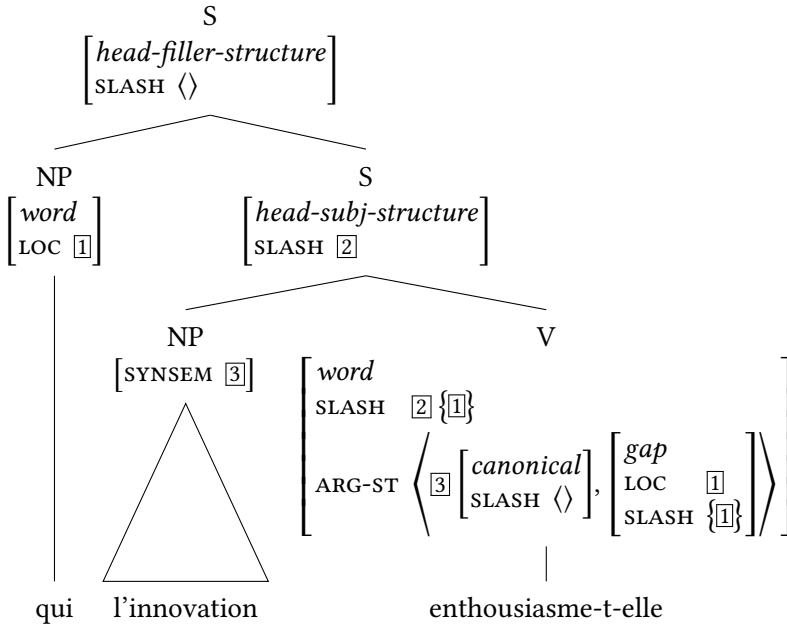

Figure 16.31: Simple extraction

Ginzburg & Sag (2000: 7) define a variety of different constructions to account for interrogatives and relative clauses in English. For example, *wh-int-cl* (*wh*-questions with extraction), *polar-int-cl* (polar questions) and *in-situ-int-cl* (question without extraction) all have certain semantic properties in common (they denote a question) and are therefore all subtypes of *inter-cl*. But only *wh-int-cl* is also a subtype of *head-filler-structure*.<sup>21</sup>

I adopt a similar analysis, but with the type hierarchy of *clause* from Winckel & Abeillé (2020), adapted from Abeillé & Godard (2007: 48). The hierarchy is given in Figure 16.32 on page 430. This hierarchy differs from Ginzburg & Sag (2000: 7), because in their proposal relative clauses are all headed by a filler, and hence a subtype of *head-filler-structure*.<sup>22</sup> I have argued above that *que*, *qui* and *dont* in French are complementizers and not fillers (Section 2.3.1). As a consequence, only some relative clauses are a subtype of *head-filler-structure*. Furthermore, some proposals treat clefts as a special type of clause or construction (a.o. Kim 2012), but in my analysis *c'est*-clefts result from a special lexical entry of *être* ('be').

<sup>21</sup>*hd-fill-ph* in their terminology.

<sup>22</sup>This is the case for *that* relative clauses, even though in many analyses *that* is not treated as a filler.

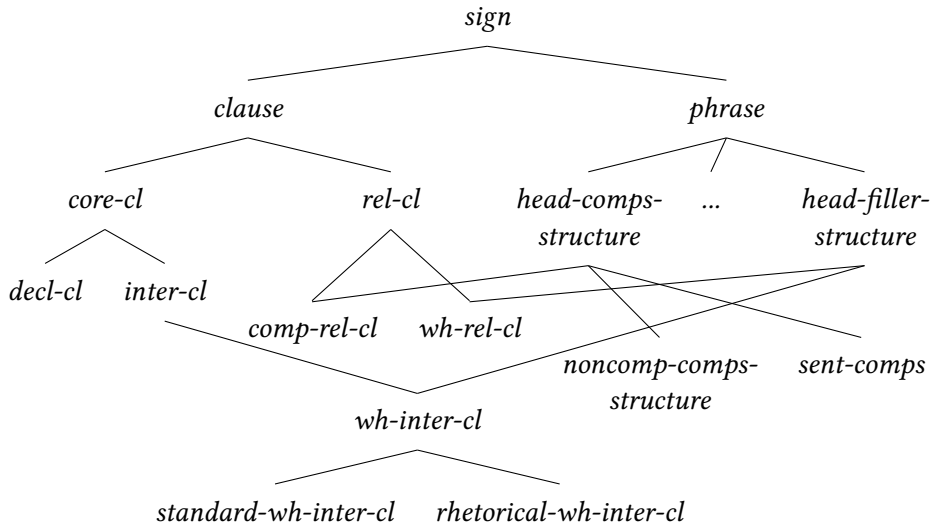

Figure 16.32: Cross-classification of *clause* and *phrase*

### 16.2.2 *Wh*-questions

I will first discuss interrogatives before turning to the other extractions. I only present *wh*-questions (with a *wh*-word), but refer the interested reader to Ginzburg & Sag (2000: 218–222) for an analysis of polar questions.

There are different question types in French, and some of them have special pragmatic properties (see a corpus study in Abeillé et al. 2012). Three of them involve extraction of the *wh*-word: SVO-questions (16.25a), questions with suffixed subjects (16.25b), and *est-ce que* questions (16.25c).<sup>23</sup> There is a fourth type: in-situ questions, with no extraction of the *wh*-word (16.25d).

- (16.25) a. Qui<sub>i</sub> l' innovation enthousiasme <sub>-i</sub>?  
 who the innovation excites  
 'Who does the innovation excite?'  
 b. Qui<sub>i</sub> (l' innovation) enthousiasme-t-elle <sub>-i</sub>?  
 who the innovation[F] excites-0-3SG.F.SBJ  
 'Who does it excite?'

<sup>23</sup> Another interrogative form is possible, but it involves *c'est*-clefting and will be addressed in Section 16.2.4.

- c. Qui<sub>i</sub> est - ce que l' innovation enthousiasme <sub>-i</sub>?  
 who is it that the innovation excites  
 'Who does the innovation excite?'
- d. L' innovation enthousiasme qui?  
 the innovation excites who  
 'The innovation excites who?'

Embedded questions must be formed via extraction, and cannot involve a suffixed subject.

- (16.26) a. Je me demande qui<sub>i</sub> l' innovation enthousiasme <sub>-i</sub>.  
 I REFL ask who the innovation excites  
 'I wonder who the innovation excites.'
- b. ?? Je me demande qui<sub>i</sub> (l' innovation) enthousiasme-t-elle <sub>-i</sub>.  
 I REFL ask who the innovation[F] excites-0-3SG.F.SBJ  
 'I wonder who the innovation excites.'
- c. Je me demande qui<sub>i</sub> est - ce que l' innovation  
 I REFL ask who is it that the innovation  
 enthousiasme <sub>-i</sub>.  
 excites  
 'I wonder who the innovation excites.'
- d. \* Je me demande l' innovation enthousiasme qui.  
 I REFL ask the innovation excites who  
 'I wonder who the innovation excites.'

The feature MAIN CLAUSE (MC) is a head feature of verbs, and has a value of type *bool* (+/-), positive for the main clause and negative for embedded clauses. Direct questions are [MC +] and embedded questions [MC -].<sup>24</sup>

To account for the different question types, I assume that subjects can be realized as clitics if the verb subcategorizes for an extracted interrogative phrase. Clitic doubling is also allowed, thus the subject may be realized as a clitic and as an NP like in (16.25b). However, subject suffixes are restricted to [MC +].

To my knowledge, there is no complete HPSG analysis of *est-ce que* questions in French. Abeillé et al. (2012: 70) treat *est-ce que* as a complementizer and assume

<sup>24</sup>The topic of subject-verb inversion in French is not completely orthogonal to our main concern, given that sentence-final subjects seem to bear focus (Lahousse 2011). In this respect, the FBC constraint certainly makes some prediction for subject-verb inversion, but there are no empirical data bearing on this issue yet so I leave it for future work.

a special subtype of interrogatives, *est-ce-que-cl*. If this is on the right track, the type *est-ce-que-cl* should have two subtypes, one inheriting from polar questions (*polar-int-cl*) and one inheriting from *wh*-questions with an extraction (*wh-inter-cl*). In polar *est-ce que* questions, the complementizer selects an S without subject-verb inversion and contributes the interrogative interpretation of the sentence. In a *wh*-question with *est-ce que*, the head daughter is [HEAD *comp*] and has a non-empty SLASH set. I leave a more detailed analysis of *est-ce que* questions for future work and, for the sake of simplicity, I do not include *est-ce-que-cl* and its subtypes in my hierarchy of clauses (Figure 16.32).

All interrogatives are instances of *inter-cl*. Ginzburg & Sag (2000: 42) assume that objects of the type *inter-cl* have some common semantic properties. They may also have some common pragmatic properties. In my fragment, the semantic content of questions is contributed on a lexical level by the *wh*-word with an appropriate EP. For example, the interrogative *qui* can either have an empty QUE set when it is in-situ or a non-empty QUE set when it is extracted. This is shown by the lexical entry in Figure 16.33, adapted from Ginzburg & Sag (2000: 185), with a simplified semantic representation like the one adopted in the LinGO English Resource Grammar for *wh*-words.

$$\left[ \begin{array}{l} \text{PHON} \quad \langle \text{qui} \rangle \\ \text{LOC} \quad \left[ \begin{array}{l} \text{CAT|HEAD} \quad \textit{noun} \\ \text{CONT|RELS} \quad \left\langle \left[ \begin{array}{l} \textit{person} \\ \text{ARG0} \quad \bar{i} \end{array} \right], \bar{i} \left[ \begin{array}{l} \textit{which\_q} \\ \text{ARG0} \quad \bar{i} \end{array} \right] \right\rangle \end{array} \right] \\ \text{NONLOC} \quad \left[ \begin{array}{l} \text{QUE} \quad \{\bar{i}\} \vee \{\} \\ \text{REL} \quad \{\} \end{array} \right] \\ \text{ARG-ST} \quad \langle \rangle \end{array} \right]$$

Figure 16.33: Lexical entry for interrogative *qui* ('who')

As far as information structure is concerned, I have also argued in Section 11.4 that in-situ questions may not always involve focalization. Therefore, I do not propose any constrain on the type *inter-cl*, but acknowledge that other semantic or pragmatic aspects may be involved.

### 16.2.2.1 Extracted *wh*-phrase

Objects of the type *wh-inter-cl* inherit the properties of *head-filler-structure*. The filler in *wh-inter-cl* must have a non-empty QUE value (see the Filler Inclusion Constraint in Ginzburg & Sag 2000: 228). As a consequence, in-situ interrogative

words are never used in *wh-inter-cl* structures. The element in the *QUE* set is saturated when the filler combines with the S on the clausal level. This is reflected by the definition of *wh-inter-cl* in (16.27).

$$(16.27) \quad wh\text{-inter-cl} \Rightarrow \left[ \begin{array}{l} \text{QUE} \quad \boxed{1} \\ \text{HEAD-DTR} \quad \left[ \text{QUE} \{ \boxed{2} \} \cup \boxed{1} \right] \\ \text{NHEAD-DTRS} \quad \langle \left[ \text{QUE} \{ \boxed{2} \} \right] \rangle \end{array} \right]$$

Figure 16.34 demonstrates the analysis of the *wh*-question in (16.25a). Through the *NONLOC* Amalgamation Principle (16.23), the value of *QUE* is structure-shared with the whole filler phrase. This is how pied-piping structures like (16.28) are accounted for as well, as illustrated by Figure 16.35 on page 435.

(16.28) [De l' anniversaire de qui]<sub>i</sub> tu parles <sub>-i</sub>?  
of the birthday of who you talk  
‘Whose birthday are you talking about?’

Furthermore, I assume cross-classifications of *clause* and *speech-act*. The type hierarchy of *speech-act* is given in Figure 16.36 on page 436. Speech acts refer to the act performed when expressing an utterance. Typically, we think of interrogatives as requests for information, and in our analysis this speech act is defined as *standard-question*. Interrogatives can, however, be non-standard, as is the case in rhetorical questions. Thus all *wh*-questions are not necessarily focalizations. I presented in Section 11.2 some examples with felicitous extraction out of the subject, such as (11.9) reproduced in (16.29). I argued that it is probably best analyzed as a rhetorical question, where the filler is a continuation topic in the context of the utterance. This explains why extraction out of the subject is felicitous. A rhetorical question is a “biased question whose answer is Common Ground and whose dialogue impact requires the activation of such a content” (Marandin 2008: 441).

(16.29) [De quel pays]<sub>i</sub> [la dépense militaire <sub>-i</sub>] dépasse annuellement  
of which country the budget military exceeds yearly  
mille milliards de dollars [...] ?  
thousand billion of dollars  
‘Of which country does the military budget exceed yearly 1000 B.  
dollars?’

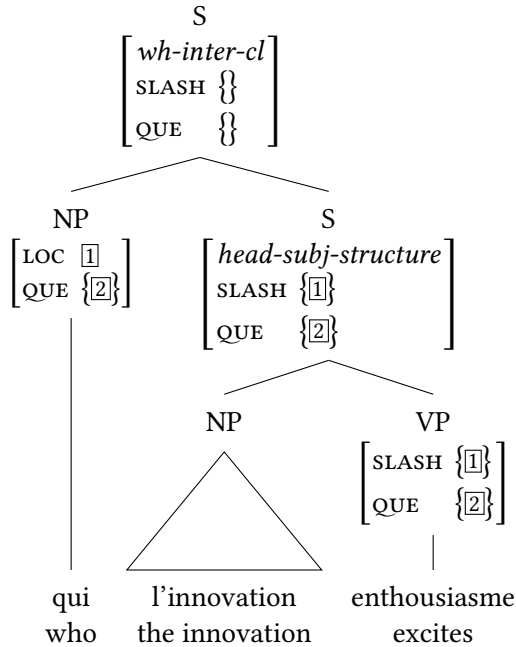

Figure 16.34: Simplified tree for “Qui<sub>i</sub> l’innovation enthousiasme <sub>-i</sub>?” (‘Who does the innovation excite?’)

I assume that all subtypes of *inter-cl* can inherit from either *standard-question* or *non-standard-question*. A linguistic object can therefore be *wh-inter-cl* and *standard-question*: these objects are *standard-wh-inter-cl*. A linguistic object can also be *wh-inter-cl* and *non-standard-question*: these objects are *non-standard-wh-inter-cl*.

I propose the constraint (16.30) on information structure for standard *wh*-questions, borrowed from Winckel & Abeillé (2020: 117)<sup>25</sup>:

(16.30) *standard-wh-inter-cl* →

$$\left[ \begin{array}{l} \text{HEAD-DTR} \quad \left[ \text{INDEX } \boxed{1} \right] \\ \text{NHEAD-DTRS} \quad \left\langle \begin{array}{l} \text{INDEX} \quad \boxed{2} \\ \text{ICONS-KEY} \quad \left[ \begin{array}{l} \textit{semantic-focus} \\ \text{TARGET } \boxed{2} \\ \text{CLAUSE } \boxed{1} \end{array} \right] \end{array} \right\rangle \end{array} \right]$$

<sup>25</sup>The main difference is that Winckel & Abeillé define this constraint on *wh-inter-cl*. The FBC constraint then excludes extraction of the complement of topic subjects, allowing only extraction out of non-topic subjects. I doubt that it is what is at stake in example (16.29) and therefore think that it is necessary to make a distinction between the speech acts involved.

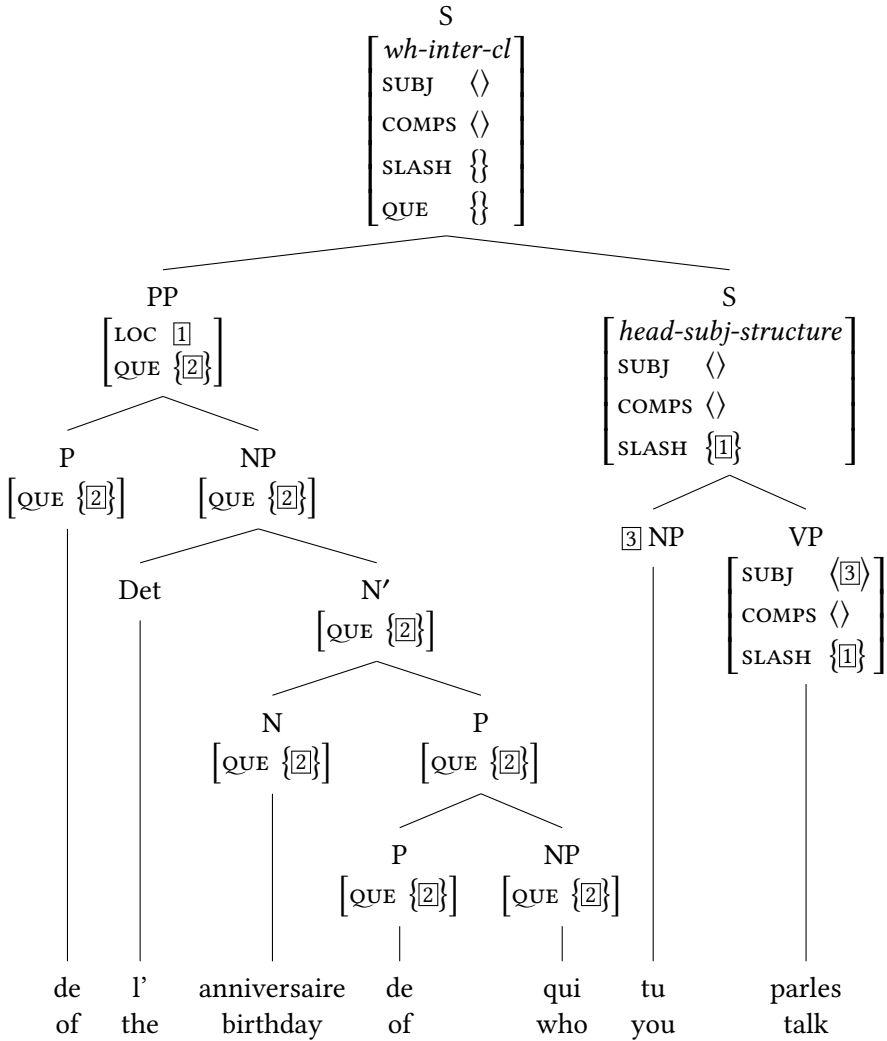
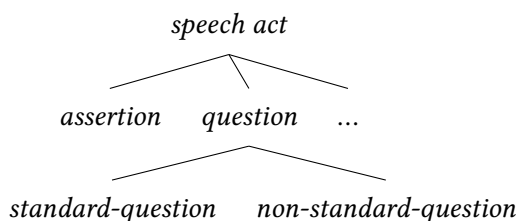

Figure 16.35: Simplified tree for *[De l'anniversaire de qui] tu parles -i?* ('Whose birthday are you talking about?')

Figure 16.36: Type hierarchy of *speech-act*

The exact information structure for non-standard questions would need further investigation. I assume for the time being that non-standard *wh*-questions imply a *non-focus* object in the *ICONS* list, though this is most probably an oversimplification.

$$(16.31) \quad \textit{non-standard-wh-inter-cl} \rightarrow \left[ \begin{array}{l} \text{HEAD-DTR} \left[ \text{INDEX } \boxed{1} \right] \\ \text{FILLER-DTR} \left[ \begin{array}{l} \text{INDEX } \boxed{2} \\ \text{ICONS-KEY} \left[ \begin{array}{l} \textit{non-focus} \\ \text{TARGET } \boxed{2} \\ \text{CLAUSE } \boxed{1} \end{array} \right] \end{array} \right] \end{array} \right]$$

### 16.2.2.2 *Wh*-phrase in situ

As stated previously, in-situ *wh*-words have an empty *QUE* set. The type *in-situ-int-cl* is constrained to be  $[MC +]$ , so that it cannot apply to embedded questions (Ginzburg & Sag 2000: 271). However, if there are several *wh*-words in an embedded question, only one has to be extracted, the other one(s) can remain in situ. Additional rules are necessary to account for superiority effects in questions (Ginzburg & Sag 2000: 247–254).

The discussion around the pragmatic status of in-situ questions was briefly touched upon in Section 12.2.6. At present there is not enough evidence concerning the real status of the *wh*-word in situ, but it would be possible, for example, to constrain *in-situ-int-cl* to be backgrounded or to be discourse-given.

### 16.2.3 Relative clauses

Just as extracted interrogative words have a non-empty *QUE* set, relative words have a non-empty *REL* set. A *wh*-word like *où* ('where') can be used as an interrogative word or as a relative word. Hence, it has the lexical entry in Figure 16.37.<sup>26</sup>

<sup>26</sup>French *où* can also have a temporal interpretation, but I disregard this detail as it is unrelated to my analysis.

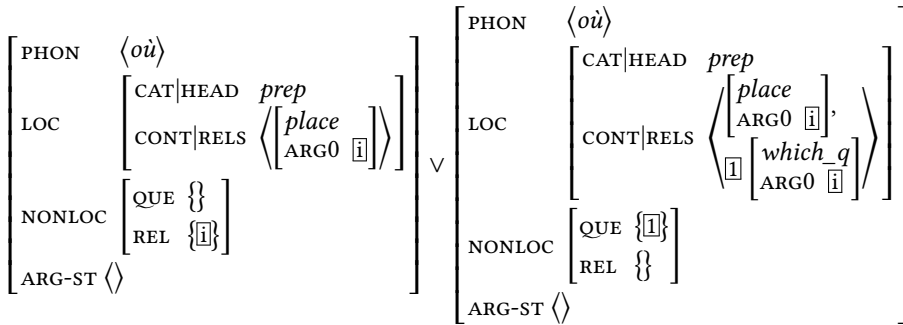

Figure 16.37: Lexical entry for the *wh*-word *où* ('where')

According to Godard (1988), relative words in French are either relative pronouns (e.g. *où* 'where', *lequel* 'which') or complementizers (e.g. *dont* 'of which').<sup>27</sup> Details of her arguments are presented in Section 2.3.1. I adopt Abeillé & Godard's (2007) cross-classification of relative clauses. I assume with them that only relative pronouns or PPs comprising relative pronouns can serve as fillers, and that complementizers are heads (see also Borsley & Crysmann 2021). Following the type hierarchy of *clause* presented in Figure 16.32, relative clauses (*rel-cl*) either inherit from *head-comps-structure* and are *comp-rel-cl* or they inherit from *head-filler-structure* and are *wh-rel-cl*.

Relative clauses are headed by a verbal category, i.e. either a *verb* or a *comp(lementizer)*, see Figure 16.3.<sup>28</sup> Relative clauses have an empty SLASH set, because extraction out of relative clauses is not allowed in French, and an empty REL set for the same reason.

$$(16.32) \quad \textit{rel-cl} \rightarrow \left[ \begin{array}{l} \text{HEAD} \left[ \begin{array}{l} \textit{verbal} \\ \text{MOD} \left[ \begin{array}{l} \text{HEAD } \textit{noun} \\ \text{SPR } \langle \rangle \end{array} \right] \end{array} \right] \\ \text{SLASH } \{ \} \\ \text{REL } \{ \} \end{array} \right]$$

<sup>27</sup>Contrary to Sag (1997), who analyses the relativizer *that* as a relative pronoun, homonymous with the complementizer *that*.

<sup>28</sup>I do not discuss here gapless and verbless relatives in French. See Bilbiie & Laurens (2010) for verbless relative clauses and Abeillé & Godard (2007) for HPSG analysis of gapless relative clauses.

Relative clauses modify NPs.<sup>29</sup> We also follow Kuno's (1976) claim that extraction in relative clauses is topicalization. In Song's (2017) model, relative pronouns and complementizers do not have an information structure status, thus the relative phrase is not the topic of the relative clause (contra Bresnan & Mchombo 1987 a.o.). Furthermore, not all languages have relative phrases to introduce relative clauses and bear the topic function. Rather, the antecedent serves as the topic of the relative clause. That the antecedent is a topic with respect to the relative clause is a semantic contribution of the relative clause (via C-CONT). The following constraint can then be added to the French fragment:<sup>30</sup>

$$(16.33) \quad rel-cl \rightarrow \left[ \begin{array}{l|l|l} \text{HEAD} & \text{MOD} & \text{INDEX} \quad \boxed{i} \\ \text{CONT} & \text{CLAUSE-KEY} & \boxed{e} \\ \text{C-CONT} & \text{ICONS} & \left\langle \left[ \begin{array}{l} \textit{topic} \\ \text{TARGET} \quad \boxed{i} \\ \text{CLAUSE} \quad \boxed{e} \end{array} \right] \right\rangle \end{array} \right]$$

### 16.2.3.1 *comp-rel-cl*

*Qui* ('who') relative clauses are extractions of the subject (regardless of animacy); *que* ('that') relative clauses are extractions of the object; and both *qui* and *que* are complementizers. Complementizers select an S complement. The complementizer *qui* is a variant of *que* used whenever the S complement has a gapped subject. It follows that, in long distance dependencies, *qui* is used to introduce the S containing the missing subject, and not as the head of the relative clause, see

<sup>29</sup>Jackendoff (1977) suggests that restrictive relative clauses attach to N' while non-restrictive relative clauses attach to NP. My analysis is compatible with this proposal, if the value of SPR is left unconstrained in (16.32). However, it would then be necessary to explain how restrictive relative clauses can attach to coordinated nouns (Kiss 2005: 293):

- (i) la femme et l' enfant [dont Nicole a parlé hier –]  
 the woman and the child of.which Nicole has talked yesterday  
 'the woman and the child that Nicole talked about yesterday'

<sup>30</sup>The constraint in (16.33) differs from a similar constraint proposed by Song (2017: 182) because he assumes that all relatives are *filler-head-str*. In (16.33), the antecedent, and not the filler, is the topic of the relative clause. (16.33) is also more compatible with the analysis of relative clauses without a gap in non-standard French, in which the antecedent is the topic (Abeillé & Godard 2007):

- (i) (Deulofeu 1981; cited by Abeillé & Godard 2007: 38)  
 Vous avez des feux [qu' il faut appeler les pompiers tout de suite].  
 you have some fires that it must call.INF the firemen all at now  
 'There are some fires that one needs to call the firemen immediately.'

example (16.34). This alternation is known as the *que-qui* rule (see a.o. Pesetsky 1982, Koopman & Sportiche 2014).

- (16.34) a. Je veux [que Daniel vienne]<sub>comp</sub>.  
 I want that<sub>que</sub> Daniel comes  
 ‘I want Daniel to come.’
- b. (Melis 1988: 194)  
 l’ homme [que je veux [qui – vienne]<sub>comp</sub>]<sub>RC</sub>  
 the man that<sub>que</sub> I want that<sub>qui</sub> comes  
 ‘the man who I want to come’ (i.e., I want that man to come)

The two lexical entries for *que* and complementizer *qui* in Figure 16.38 are directly borrowed from Abeillé & Godard (2007: 50). The complement S must be finite (see Section 2.3.1).

$$\left[ \begin{array}{l} \text{PHON } \langle que \rangle \\ \text{SYNSEM|LOC|CAT} \left[ \begin{array}{l} \text{HEAD } comp \\ \text{MARKING } que \\ \text{COMPS } \left\langle \left[ \begin{array}{l} \text{VFORM } finite \\ \text{SUBJ } \langle \rangle \end{array} \right] \right\rangle \end{array} \right] \end{array} \right]$$
(a) *que*

$$\left[ \begin{array}{l} \text{PHON } \langle qui \rangle \\ \text{SYNSEM|LOC|CAT} \left[ \begin{array}{l} \text{HEAD } comp \\ \text{MARKING } que \\ \text{COMPS } \left\langle \left[ \begin{array}{l} \text{VFORM } finite \\ \text{SUBJ } \langle [gap] \rangle \end{array} \right] \right\rangle \end{array} \right] \end{array} \right]$$
(b) Complementizer *qui*

Figure 16.38: Lexical entries for the French complementizers *que* and *qui*

Notice the presence of a syntactic feature MARKING, defined for complementizers and prepositions (also possibly nouns, see a.o. Sportiche 1998: 159; I will come back to this issue in Section 17.1). The value of MARKING is an object of type *marking*, whose hierarchy is given in Figure 16.39. Complementizers may have a MARKING *que* or *dont*. Prepositions have a MARKING value matching their form (e.g. *de*, *sur*).

The MARKING for PPs ensures that the right preposition is selected if the PP is a complement; ensures the use of the right clitic for à-PP (*lui* for dative, *y* for locative); and also ensures that *dont* is used to only relativize a *de*-PP. Hence, the lexical entry for *dont* is (16.35).

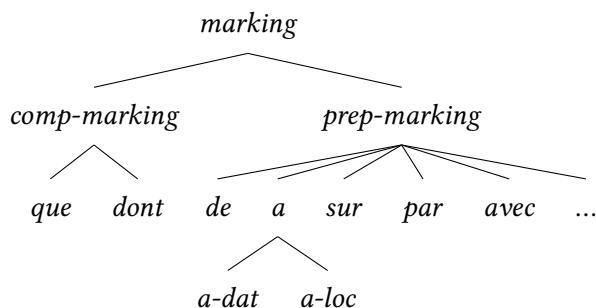
Figure 16.39: Type hierarchy of *marking*(16.35) Lexical entry for *dont*:

PHON	$\langle dont \rangle$						
SYNSEM LOC CAT	<table style="border-collapse: collapse;"> <tr> <td style="border-right: 1px solid black; padding: 5px;">HEAD</td> <td style="padding: 5px;"><i>comp</i></td> </tr> <tr> <td style="border-right: 1px solid black; padding: 5px;">MARKING</td> <td style="padding: 5px;"><i>dont</i></td> </tr> <tr> <td style="border-right: 1px solid black; padding: 5px;">COMPS</td> <td style="padding: 5px;"><math>\langle S [ \text{SLASH } \{ [ \text{MARKING } de ] \} ] \rangle</math></td> </tr> </table>	HEAD	<i>comp</i>	MARKING	<i>dont</i>	COMPS	$\langle S [ \text{SLASH } \{ [ \text{MARKING } de ] \} ] \rangle$
HEAD	<i>comp</i>						
MARKING	<i>dont</i>						
COMPS	$\langle S [ \text{SLASH } \{ [ \text{MARKING } de ] \} ] \rangle$						

In the standard relative clauses discussed so far, the complementizers take as complement an S with a non-empty SLASH set.<sup>31</sup> The gap is coindexed with the antecedent of the relative clause. The whole relative clause is monoclausal, the main event being the event of the main verb (hence of the non-head daughter). This leads to the definition of *comp-rel-cl* in (16.36). Notice that this constraint overwrites the default SLASH Amalgamation Principle (16.22), because the

<sup>31</sup>But notice that the lexical entries for *que/qui* in Figure 16.38 can take complements with empty SLASH sets. This is necessary for two reasons: (i) they can introduce a gapless clause as complement of a verb (e.g. *dire* 'say'); and (ii) in non-standard French, *que/qui* relative clauses can be gapless (see fn. 30). Furthermore, in non-standard French, the gap in the *que/qui* relative clause sometimes does not correspond to an NP:

- (i) J' ai besoin du livre.  
I have need of.the book  
'I need the book.'
- (ii) le livre dont j' ai besoin (standard French)  
the book of.which I have need  
'the book I need'
- (iii) le livre que j' ai besoin (non-standard French)  
the book that I have need  
'the book I need'

mother node does not inherit from the SLASH values of its daughters, even though *comp-rel-cl* is an instance of *head-comps-str*.<sup>32</sup> Furthermore, because *rel-cl* may not have an empty SLASH set in French, the constraint means that the S complement of the complementizer necessarily has only one element in its SLASH set in French.<sup>33</sup>

$$(16.36) \quad \textit{comp-rel-cl} \rightarrow \left[ \begin{array}{l} \text{CLAUSE-KEY} \quad \boxed{e} \\ \text{SLASH} \quad \boxed{1} \\ \text{HEAD-DTR} \quad \left[ \text{HEAD} \left[ \begin{array}{l} \textit{comp} \\ \text{MOD} \quad \boxed{1} \end{array} \right] \right] \\ \text{NHEAD-DTRS} \quad \left\langle \left[ \begin{array}{l} \text{LOC} | \text{CLAUSE-KEY} \quad \boxed{e} \\ \text{NON-LOC} | \text{SLASH} \quad \{ \boxed{1} \} \end{array} \right] \cup \boxed{1} \right\rangle \end{array} \right]$$

Figure 16.40 shows the relative clause introduced by a complementizer in (16.37).

- (16.37) mes collègues<sub>i</sub> [que l' innovation enthousiasme <sub>-i</sub>]  
 my colleagues that the innovation excites  
 'my colleagues that the innovation excites'

### 16.2.3.2 *wh-rel-cl*

I will assume that fillers in relative clauses must be PPs: subjects and objects are extracted with a complementizer, and pied-piping of an NP is not allowed in French, as illustrated in (16.38).<sup>34</sup>

<sup>32</sup>Other kinds of *head-comps-str* are *noncomp-comps-structure* and *sent-comps*. The type *noncomp-comps-structure* is defined as  $[\text{HEAD } \textit{non-comp}]$ . The type *sent-comps*, for sentential complements introduced by a complementizer, is defined as  $[\text{MOD } \textit{none}]$ .

<sup>33</sup>Abeillé & Godard (2007) assume that *dont* in standard French takes a finite complement, and that *comp-rel-cl* hence always implies a finite complement. But infinite *dont*-CPs seem at least marginally acceptable (see Section 2.3.1), so I see no need to rule them out.

The rule in (16.36) implies that the non-head daughter has a non-empty SLASH set. To account for non-standard relative clauses, a disjunction is probably necessary: either the non-head daughter has an empty SLASH set and has then  $[\text{MARKING } \textit{que}]$  (not compatible with *dont*), or (16.36) applies.

<sup>34</sup>But see a discussion of some exceptions in Section 11.1.

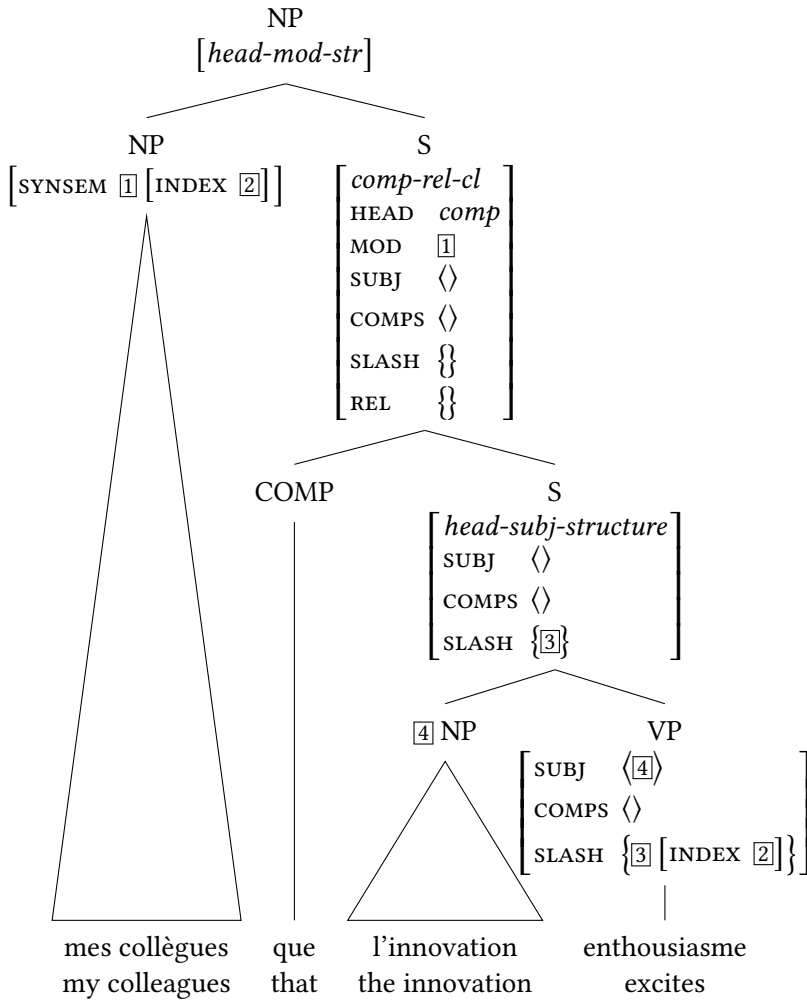

Figure 16.40: Simplified tree for *mes collègues [que, l'innovation enthousiasme -]* ('my colleagues that the innovation excites')

- (16.38) a. the people who live in Purus, [the majority of whom] are poor<sup>35</sup>  
 b. ?? les habitants de Purús, [la majorité desquels] sont  
 the inhabitants of Purus the majority of.the.which are  
 pauvres  
 poor

The definition of *wh-rel-cl* is given in Figure 16.41. The non-local feature REL of the filler is coindexed with the antecedent of the relative clause. The relative clause is headed by the verb.

$$wh\text{-rel-cl} \rightarrow \left[ \begin{array}{l} \text{HEAD-DTR} \left[ \begin{array}{l} \text{HEAD} \left[ \begin{array}{l} \textit{verb} \\ \text{MOD} \left[ \text{INDEX } \boxed{i} \right] \end{array} \right] \end{array} \right] \\ \text{FILLER-DTR} \left[ \begin{array}{l} \text{HEAD } \textit{prep} \\ \text{REL } \{ \boxed{i} \} \end{array} \right] \end{array} \right]$$

Figure 16.41: Definition of *wh-rel-cl*

Figure 16.42 shows the relative clause introduced by a filler in (16.28). Notice that *qui* ('who') here is not the complementizer but a relative pronoun that is used only as a complement to prepositions.<sup>36</sup> In accordance with the NONLOC Amalgamation Principle (16.23), the value of REL of the relative pronoun is percolated to the maximal projection of the filler.

- (16.39) Gaetan, [[de l' anniversaire de qui]<sub>i</sub> tu parles <sub>-i</sub>]  
 Gaetan of the birthday of who you talk  
 'Gaetan, whose birthday you are talking about'

### 16.2.4 *C'est*-clefts

In my analysis, I will distinguish two kinds of *c'est*-clefts, which both involve focalization of the pivot. I leave aside presentationals introduced by *c'est* or *il y a* (see Karssenbergh & Lahousse 2018). The first kind of *c'est*-cleft is the one usually discussed in the French literature (Doetjes et al. 2004). It has a *que*-clause, similar to the *that*-clause in English *it*-clefts. An analysis of these *c'est*-clefts was already published in Winckel & Abeillé (2020).

<sup>35</sup><https://www.theguardian.com/environment/andes-to-the-amazon/2013/may/24/peru-amazon-rainforest>, last access 25/07/2020

<sup>36</sup>There are hence four versions of *qui* ('who'): the interrogative *qui* extracted, the interrogative *qui* in situ (Figure 16.33), the complementizer *qui* (Figure 16.38b) and the relative pronoun *qui*.

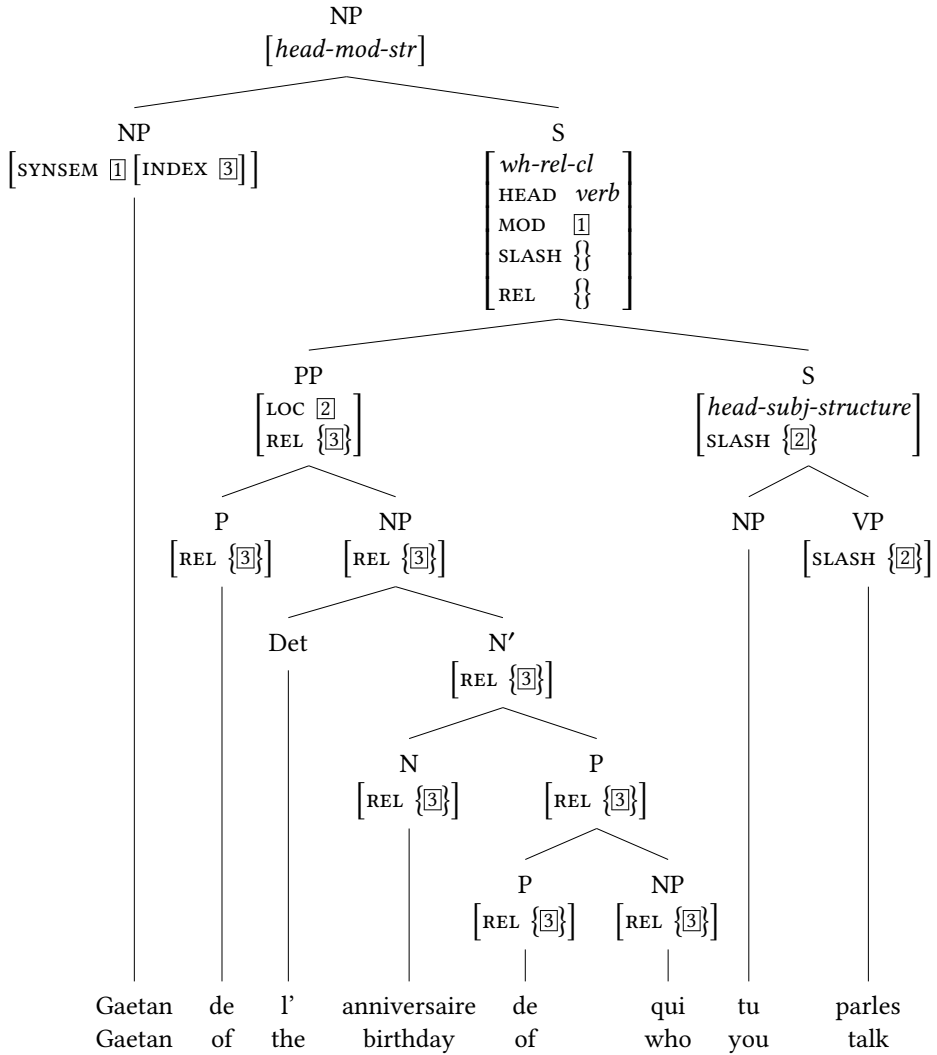
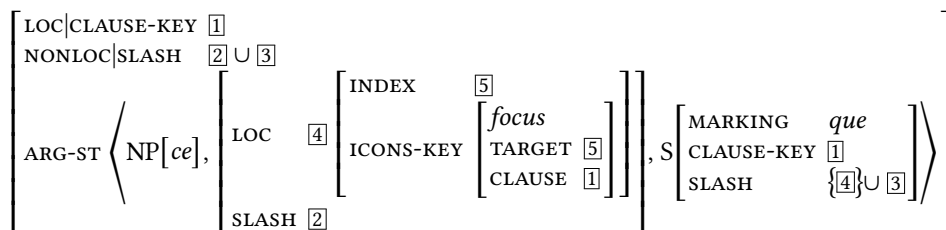

Figure 16.42: Simplified tree for *Gaetan*,  $[[de\ l'anniversaire\ de\ qui]_i\ tu\ parles\ -_i]$  ('Gaetan, whose birthday you are talking about')



I assume the entry for *être* in Figure 16.43, which takes (expletive) *ce* as a subject and two complements: the pivot, which can be of any category; and the *que*-clause with a gap coindexed with the pivot.<sup>37</sup> The pivot is interpreted as focus, and the whole *c'est*-cleft is treated as a single semantic clause (the main event is the event denoted by the finite verb of the *que*-clause).

Figure 16.43: *être*<sup>1</sup> in *c'est*-cleft

The lexical entry in Figure 16.43 overrides the default Slash Amalgamation Principle (16.22): the verb inherits the SLASH information of the pivot and the SLASH information of the *que*-clause that is not coindexed with the pivot. This enables extraction out of the *que*-clause (see the discussion in Section 15.3, and (15.15) for an attested example). Extraction out of the pivot is allowed as well:<sup>38</sup>

- (16.40) a. (Winckel & Abeillé 2020)
- un élève [dont<sub>i</sub> [c' est toujours [le père <sub>-i</sub>]<sub>j</sub> que je vois <sub>-j</sub>  
 a pupil of.which it is always the father that I see  
 aux réunions]]  
 at.the meetings  
 'a pupil of which it is always the father that I see at the meetings'

<sup>37</sup>It follows from Figure 16.43 that colloquial French should allow *que*-clauses in *c'est*-clefts like (ii) in which the gap does not correspond to an NP (see fn. 31 on page 440):

- (i) C' est ce livre dont j' ai besoin. (standard French)  
 it is the book of.which I have need  
 'It's the book that I need.'
- (ii) C' est ce livre que j' ai besoin. (non-standard French)  
 it is the book that I have need  
 'It's the book that I need.'

<sup>38</sup>Example (16.40b) from <http://mysticlolly.eklablog.com/la-maitresse-a-une-vie-a45200461>, last access 03/08/2020

- b. les enfants [dont<sub>i</sub> [c' est [les parents <sub>-i</sub>]<sub>j</sub> qui <sub>-j</sub> vous ont repérée]]  
 the children of.which it is the parents who you.ACC have spotted  
 'the children of whom it is the parents who spotted you' (i.e. the parents of this child spotted you)

Notice that the *que*-clause can be elided. Furthermore, at least in colloquial French, the whole pivot can be extracted, as in (16.41a). Bresnan & Mchombo (1987) also provide example (16.41b) for English that they judge acceptable.

- (16.41) a. (title of a song by Renaud, 1980)  
 Où<sub>i</sub> [c' est <sub>-i</sub> qu' j' ai mis mon flingue <sub>-i</sub>]?  
 where it is that I have put my gun  
 'Where did I leave my gun?'  
 b. (Bresnan & Mchombo 1987: 759)  
 Who<sub>i</sub> [it was <sub>-i</sub> that Marilyn suspected <sub>-i</sub>]?

Extraction in (16.41) is possible because the pivot and the interrogative filler are both focus. There is thus no discourse clash. However, relativization is not felicitous in this configuration. This contrast with interrogatives is also noted by Bresnan & Mchombo (1987: 759) for English.

- (16.42) a. (Bresnan & Mchombo 1987: 759)  
 \* the person who<sub>i</sub> [it was <sub>-i</sub> that Marilyn suspected <sub>-i</sub>]  
 b. \* Marine, dont [c' est <sub>-i</sub> que je me méfiais]  
 Marine of.which it was that I REFL distrusted  
 'Marine, who it was that I did not trust' (i.e. Marine, it was her that I did not trust)

The contrast can be straightforwardly accounted for in the analysis of relative clauses and *c'est*-clefts sketched above. The clefted pivot should be focus (constrained by the element in the SLASH list) with respect to the semantic head, or CLAUSE-KEY, of the clause (*suspected/méfiait*), but the antecedent of the relative clause is constrained to be topic with respect to the semantic head of the relative (which is again *suspected/méfiait*). This results in a discourse clash and the sentence is unacceptable.<sup>39</sup>

<sup>39</sup>This case is a further argument in favor of encoding information structure inside LOC, see Section 16.1.3.

The *que*-clause in Figure 16.43 is not a relative clause, but a sentential complement with a gap. Relative clauses have an empty SLASH set and therefore cannot match the description of the selected complement. The fact that the *que*-clause is a sentential complement could explain it allows extraction, in contrast to extraction out of relative clauses. Cross-linguistically, the sentential complement in *it*-clefts does not always have the same syntactic properties as relative clauses. For example, in Martinique Creole, relative clauses have an optional post-clausal article *a*, while sentential complements in *it*-clefts do not (Stéphane Térosier, p.c.):

- (16.43) (Stéphane Térosier, p.c.)
- a. jardinié a man wè (a)  
gardner DET 1SG see DET  
'the gardner that I saw'
  - b. Sé jardinié a man wè (\*a)  
FOC gardner DET 1SG see DET  
'It is the gardner that I saw.'

The pivot in Figure 16.43 can be of any category, for example a PP as in (16.44a). It may also be an interrogative phrase, at least in colloquial French, like in (16.44b). Figure 16.44 shows the structure of (16.44a).

- (16.44) a. C' est de Gaetan que je parle.  
it is of Gaetan that I talk  
'It's Gaetan that I'm talking about.'
- b. C' est [avec qui]<sub>i</sub> que tu parles <sub>-i</sub> ?  
it is with who that you talk  
'Who are you talking to?'

The second kind of *c'est*-cleft always has an NP pivot and the second complement closely resembles a relative clause. Compare (16.45) with (16.44a).

- (16.45) C' est Gaetan de qui je parle.  
it is Gaetan of who I talk  
'It's Gaetan that I'm talking about.'

These *c'est*-clefts have not received much attention, thus I have to make several assumptions, mostly relying on consistency within the analysis. Undoubtedly, more work needs to be done on this kind of *c'est*-clefts. First, I will assume that the second complement of such clefts is indeed a relative.



The pivot in this sentence seems to be contrastive.<sup>40</sup> For this reason, I assume that it is a contrastive topic. Because *contrast-topic* is a subtype of *topic*, this analysis is compatible with the information structure of relative clauses. And because contrastive topics are non-focus, the subextraction in (16.46) does not violate the FBC constraint.

Consequently, I assume the second entry for *être* in Figure 16.45, which takes (expletive) *ce* as a subject and two complements: an NP pivot and a relative clause that modifies an NP coindexed with the pivot. The pivot is interpreted as contrastive topic, and the whole *c'est*-cleft is considered a single clause, as in Figure 16.43.

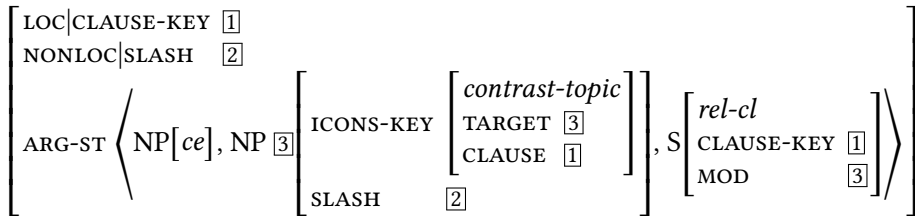

Figure 16.45: *être*<sup>2</sup> in *c'est*-cleft

The lexical entry in Figure 16.45 predicts that extraction out of the pivot is allowed, while extraction out of the relative clause is ruled out (the SLASH set of relative clauses is empty). These predictions need to be corroborated with empirical evidence, which I leave for future work. Figure 16.46 shows the structure of (16.45).

Notice that the *c'est*-cleft in (16.47) can be an instance of both kinds of clefts, and the *que*-clause can be either a sentential complement or a relative clause. This should not be a problem, because in the present analysis each possibility leads to a different information structure for the pivot.

- (16.47) C' est mes collègues que l' innovation enthousiasme.  
 it is my colleagues that the innovation excites  
 'It's my colleagues that the innovation excites.'

### 16.2.5 Long-distance dependencies

On the clausal level, the head's CLAUSE-KEY is identified with its INDEX (Song 2017: 120). This ensures that the whole clause shares the same CLAUSE-KEY down the tree.

<sup>40</sup>In the book, this scene, in which Jean-Christophe avoids Ana's gaze, is echoing a previous scene, in which Ana was avoiding Jean-Christophe's gaze.

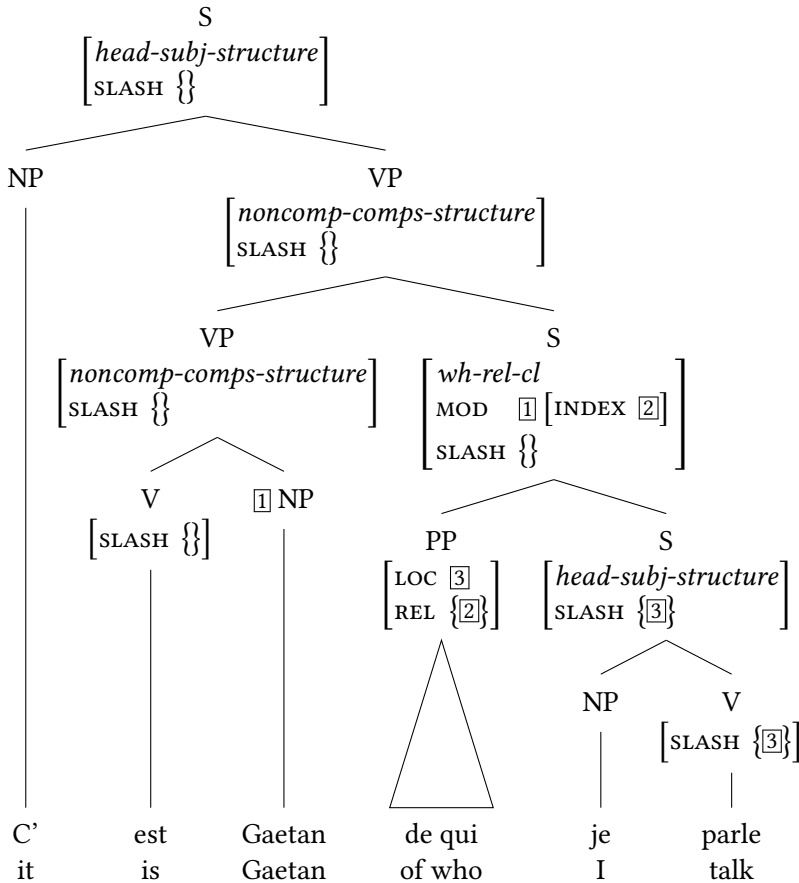

Figure 16.46: Simplified tree for *C'est Gaetan de qui je parle*. ('It's Gaetan that I'm talking about.')

(16.48) *clause* →

$$\left[ \text{HEAD-DTR} \left[ \text{HOOK} \left[ \begin{array}{l} \text{INDEX} \\ \text{CLAUSE-KEY} \end{array} \left[ \begin{array}{l} \text{c} \\ \text{c} \end{array} \right] \right] \right] \right]$$

To simplify, I will assume that sentential and infinitival subjects and complements are licensed for some verbs, and that this is part of their lexical entry.<sup>41</sup>

For example, the lexical entry for bridge verbs like *suppose* ('to suppose') subcategorizes for a sentential complement, and the lexical entry for experiencer object verbs like *agacer* ('annoy') subcategorizes for a sentential subject.

<sup>41</sup>This is subject to further restrictions that are not relevant to my analysis, see Pollard & Sag (1994: 151–156) and Webelhuth (2012) a.o. for more details.

- (16.49) a. I suppose [that you agree with me].  
 b. Je suppose [que tu es d'accord avec moi].  
 I suppose that you are of agreement with me  
 'I suppose that you agree with me.'
- (16.50) a. [That Kim was late] annoyed Lee.  
 b. [Que Kim soit en retard] agaçait terriblement Lee.  
 that Kim be.SUBJ in late annoyed awfully Lee  
 'That Kim was late annoyed Lee awfully.'

When sentential complements and sentential subjects are finite, the lexical entry additionally specifies the discourse relation between the embedded clause and the embedding clause via an *info-str* object in ICONS. The information structure may be underspecified. The *CLAUSE-KEY* of the embedded clause and the *CLAUSE-KEY* of the embedding verb are not structure-shared: this results in two different clauses.<sup>42</sup>

See as an example the lexical entry for *supposer* ('to suppose') in Figure 16.47 that licenses (16.49b). From now on, I use the shortcut *lnis* for *list of non-is* (cf. Figure 16.25).

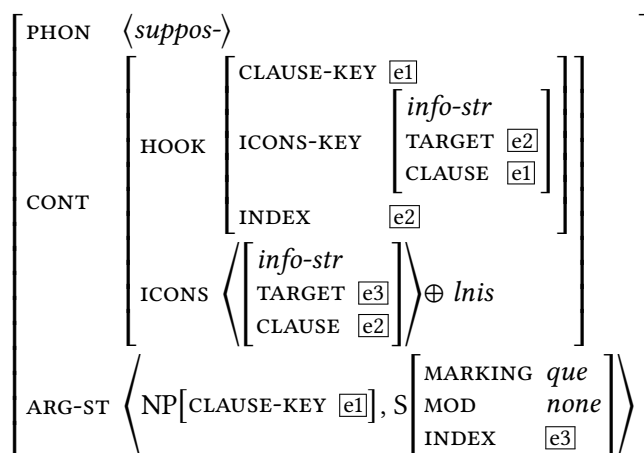

Figure 16.47: Lexical entry for *supposer* ('to suppose')

Notice that the verb in Figure 16.47 selects for a *que*-clause (therefore finite) that is not a modifier (and can thus not be a relative clause).

<sup>42</sup>Except for raising and control verbs, which co-index their *CLAUSE-KEY* with the *INDEX* (or *CLAUSE-KEY*) of the embedded clause, see Song (2017: 141). The *être* in *c'est*-clefts does the same, as discussed previously.

In general, any NP, PP, infinitival complement or infinitival subject is defined by the lexical entry of the verb that selects for it as sharing its `CLAUSE-KEY` value with its own.

Extractions out of sentential and infinitival complements are handled straightforwardly by the same mechanisms that account for extraction in general. The content of the `SLASH` set of the sentential or infinitival complement is inherited through `ARG-ST` by the embedding verb. It can then lead to interrogatives, relative clauses or *it*-clefts.



# 17 Extraction out of subject NPs

## 17.1 Noun dependents in French

So far, we have treated all *de*-dependents as *de*-PPs, but there is a long tradition in French linguistics of distinguishing between a preposition *de* that heads *de*-PPs and a weak head *de* in genitive *de*-NPs. This mostly stems from the distinction between extractable *de*-dependents and non-extractable *de*-dependents of nouns. Sportiche (1981) shows that *de*-PPs that denote a local origin cannot be extracted out of an NP, see (17.1a). Furthermore, the presence of a second *de*-dependent may block the extraction of a *de*-dependent that is otherwise acceptable, see (17.1b).

- (17.1) a. (adapted from Sportiche 1981: 225)  
\* la prison, de laquelle le transfert s' effectua avec  
the jail of which the transportation REFL performed with  
du retard  
some delay  
'the jail, from which the transportation has been performed with  
some delay'
- b. (Godard & Sag 1996: 63)  
La jeune femme dont le portrait (\*de Corot) est à la  
the young woman of.which the portrait of Corot is at the  
fondation Barnes est inconnue.  
foundation Barnes is unknown  
'The young woman whose portrait (by Corot) is at the Barnes  
foundation is unknown.'

This latter problem with multiple *de*-dependents has been analyzed either in terms of a hierarchy of semantic roles (Sag & Godard 1994, Godard & Sag 1996), or as a contrast between individual and property denoting interpretations (Kolliakou 1999, Mensching et al. 2018). It has also been explained syntactically as a distinction between extractable argument *de*-NPs and non-extractable adjunct *de*-PPs (Kolliakou 1999). I have previously argued that the problem of multiple *de*-dependents of nouns should be analyzed in semantic rather than syntactic terms (Machicao y Priemer & Winckel 2015).

Consequently, I continue to consider all *de* as prepositions and all *de*-dependents of nouns as PPs with [MARKING *de*], as also suggested by Milner (1978: 246–251) and Abeillé, Bonami, et al. (2006). I also assume that these *de*-dependents are all complements (or at least elements of the ARG-ST list of nouns), even though the distinction between arguments and adjuncts is even more blurry for dependents of nouns than for dependents of verbs.

Prepositions in French (and all Romance languages) cannot be stranded, see (17.2a). Extraction out of the *de*-PP is possible, see (17.2b), but extraction out of other PPs seems very marginal (but compare example (17.2c)). The NP complement of some prepositions can be left out (17.2d). The NP complement of other prepositions cannot: this is the case for *de*, as illustrated by (17.2e).

- (17.2) a. \*Qui<sub>i</sub> as - tu parlé avec / de -<sub>i</sub>?  
 who have you spoken with of  
 ‘Who did you speak with / about?’
- b. (Chateaubriand, Mémoires d’outre-tombe, 1ère partie, livre 4, 1848)  
 cette déclaration, dont<sub>i</sub> je me suis assuré [de la vérité -<sub>i</sub>]  
 this statement of.which I REFL have ensured of the truth  
 ‘this statement, whose truth I verified’
- c. ?l’ eau d’ irrigation dont<sub>i</sub> il plaide [pour la  
 the water of irrigation of.which he argues for the  
 rationalisation [de l’ usage -<sub>i</sub>]]<sup>1</sup>  
 rationalization of the use  
 ‘the irrigation water, whose usage he argues for the  
 rationalization of’
- d. L’ ampli de guitare fait des grésillements quand je joue  
 the amp of guitar makes some crackles when I play  
 avec.  
 with  
 ‘The guitar amp crackles when I play with (it).’
- e. \*J’ éteinds la musique quand j’ ai pas envie de.  
 I switch.off the music when I have not desire of  
 ‘I switch off the music when I don’t fancy (it).’

Therefore, the ARG-ST list of prepositions is constrained to only contain objects of type *non-gap* (see Figure 16.4). But *de* itself has only *canonical* objects in its

<sup>1</sup>Source: <https://www.djazairress.com/fr/lesoirdalgerie/208772>, last access 05/08/2020.

ARG-ST and its SLASH set is not constrained (it may be non-empty). The other prepositions are defined as having an empty SLASH set.<sup>2</sup>

To account for the semantics of prepositions, we distinguish meaningful prepositions like (17.3a) from meaningless prepositions like (17.3b). We assume that many prepositions can be either meaningful or meaningless and have then two different lexical entries (or equivalently, have a lexical entry with a disjunction).

- (17.3) a. Susanne travaille sur son balcon.  
 Susanne works on her balcony  
 ‘Susanne is working on her balcony.’
- b. Susanne travaille sur un nouveau projet.  
 Susanne works on a new project  
 ‘Susanne is working on a new project.’

The lexical entry of meaningful prepositions has a non-empty RELS list, while the lexical entry of meaningless prepositions does not introduce any EP in the RELS list.

Meaningful prepositions have their own INDEX value (probably an event) and their own ICONS-KEY, like any word that introduces an EP.

Meaningless prepositions structure-share their INDEX value with the INDEX value of the NP they subcategorize for. I also assume that all meaningless prepositions that take a complement structure-share their ICONS-KEY value with the ICONS-KEY value of their complement. This latter point conflicts somewhat with the underlying idea that semantically empty elements do not introduce an object of type *info-str* into the ICONS list of the utterance. But, because prepositions have the same INDEX value as their complement, and by virtue of the Discourse-clash Avoidance Principle (16.18) on page 425, they must have the same ICONS-KEY value. Consequently, prepositions do not introduce a new element into the ICONS list of the utterance, but merely treat the NP as the semantic head of the PP.

I assume that *de* is a meaningless preposition with the lexical entry in Figure 17.1.<sup>3</sup>

<sup>2</sup>In order for the grammar to account for marginal cases like (17.2c), the SLASH set of all prepositions could be left unconstrained.

<sup>3</sup>It could be useful to posit a separate lexical entry for *de* expressing possessive or origin, and consider it as meaningful. But this has no impact on the formalization of the FBC constraint I propose. For the sake of simplicity, I assume only one lexical entry for *de*.

Furthermore, Abeillé, Bonami, et al. (2006) define two usages of the preposition *de*, one in which it is the head, and one in which it is a marker (i.e. in *beaucoup de*, ‘many’). Here, I only consider the former, which is the use I investigated in the empirical parts.

$$\left[ \begin{array}{l} \text{PHON} \langle de \rangle \\ \text{CAT} \left[ \begin{array}{l} \text{HEAD} \textit{prep} \\ \text{MARKING} \textit{de} \end{array} \right] \\ \text{CONT} \left[ \begin{array}{l} \text{INDEX} \boxed{i} \\ \text{ICONS-KEY} \boxed{1} \\ \text{RELS} \langle \rangle \end{array} \right] \\ \text{ARG-ST} \left\langle \left[ \begin{array}{l} \textit{canonical} \\ \text{INDEX} \boxed{i} \\ \text{ICONS-KEY} \boxed{1} \end{array} \right] \right\rangle \end{array} \right]$$

Figure 17.1: Lexical entry for *de* ('of')

For a preposition like *sur* ('on') that can be used either as a meaningful preposition like in (17.3a) or as a meaningless preposition like in (17.3b), we can define the lexical entries in Figures 17.2 and 17.3, which summarizes the assumptions made so far.

$$\left[ \begin{array}{l} \text{PHON} \langle sur \rangle \\ \text{CAT} \left[ \text{HEAD} \textit{prep} \right] \\ \text{CONT} \left[ \begin{array}{l} \text{HOOK} \left[ \begin{array}{l} \text{INDEX} \textit{index} \\ \text{ICONS-KEY} \textit{info-str} \end{array} \right] \\ \text{RELS} \left\langle \left[ \begin{array}{l} \textit{ON\_REL} \\ \text{ARG0} \boxed{i} \end{array} \right] \right\rangle \end{array} \right] \\ \text{SLASH} \{ \} \\ \text{ARG-ST} \left\langle \left[ \begin{array}{l} \textit{non-gap} \\ \text{INDEX} \boxed{i} \\ \text{ICONS-KEY} \textit{info-str} \end{array} \right] \right\rangle \end{array} \right]$$

Figure 17.2: Lexical entry for meaningful *sur* ('on')

$$\left[ \begin{array}{l} \text{PHON} \langle sur \rangle \\ \text{CAT} \left[ \text{HEAD} \textit{prep} \right] \\ \text{CONT} \left[ \begin{array}{l} \text{HOOK} \left[ \begin{array}{l} \text{INDEX} \boxed{i} \\ \text{ICONS-KEY} \boxed{1} \end{array} \right] \\ \text{RELS} \langle \rangle \end{array} \right] \\ \text{SLASH} \{ \} \\ \text{ARG-ST} \left\langle \left[ \begin{array}{l} \textit{non-gap} \\ \text{INDEX} \boxed{i} \\ \text{ICONS-KEY} \boxed{1} \end{array} \right] \right\rangle \end{array} \right]$$

Figure 17.3: Lexical entry for meaningless *sur* ('on')

The extraction of the PP-dependent of a noun out of NPs takes place in a straightforward manner via the mechanisms of extraction explained earlier. Under the NONLOC Amalgamation Principle (16.23), the verb that selects an NP with a SLASH element inherits this element. There is no difference between extraction of a PP-dependent of a verb and subextraction of a PP-dependent of a noun out of an NP.

## 17.2 The subject as Designated Topic

One of the central claims in this book is that the phenomenon usually called “subject island” is actually the result of a discourse clash: Typically, the subject is the topic of the clause, and focalizing part of the subject leads to a contradiction in that the subject NP is simultaneously treated as part of the Common Ground and as the main information of the sentence (contra Grice’s maxim that a sentence should be informative) or even as unknown information (internal contradiction).

The fact that the subject is the preferred topic of the clause has been captured in several HPSG proposals. Webelhuth (2007) has a function “more thematic than” that yields a hierarchy of thematicity (subject > direct object > oblique object). I adopt here Bildhauer & Cook’s (2010) notion “Designated Topic”, which is based on the verb’s preference for a certain argument to be the topic (see also Müller, Bildhauer & Cook 2020: Section 5.3.3.2). For example, German *herrschen* (‘to reign’) in its existential meaning preferably has the locative as its topic.

(17.4) (Bildhauer & Cook 2010: 72)

Weiterhin Hochbetrieb herrscht am Innsbrucker Eisoval.  
 further high.traffic reigns at.the Innsbruck icerink  
 ‘It’s still all go at the Innsbruck icerink.’

In Bildhauer & Cook’s proposal,  $D(ESIGNATED)T(OPIC)$  is a head feature of verbs with a list as value, either empty or containing at most one *synsem* object. This object is structure-shared with one element of the ARG-ST list. For verbs with the subject as default topic, the lexical entry is then the following:

(17.5) Lexical entry for a verb with a subject default Topic:

$$\left[ \begin{array}{l} \text{SYNSEM|LOC|CAT} \\ \text{ARG-ST} \end{array} \left[ \begin{array}{l} \text{HEAD|DT} \langle \mathbb{I} \rangle \\ \text{SUBJ} \langle \mathbb{I} \rangle \\ \langle \mathbb{I} \rangle \oplus \textit{list} \end{array} \right] \right]$$

The Designated Topic is realized as topic in sentences that “involv[e] a Topic-Comment structure plus an assessment of the extent to which the Comment holds of the Topic” (Bildhauer & Cook 2010: 73). In their model, these sentences are labeled as *a(ssessment)-topic-comment*, which is itself a subtype of *topic-comment*. Song’s (2017) model also provides a hierarchy of the information structure form of sentences. Its supertype is called *sform* (*sentential form*) and the hierarchy is reproduced in Figure 17.4. Phrases inherit from both the appropriate *headed-structure* and the appropriate *sform*.<sup>4</sup>

<sup>4</sup>Separate features ensure that the whole clause keeps the same *sform*. These features are not relevant for my analysis, but see Song (2017: Chapter 7) for a detailed explanation.

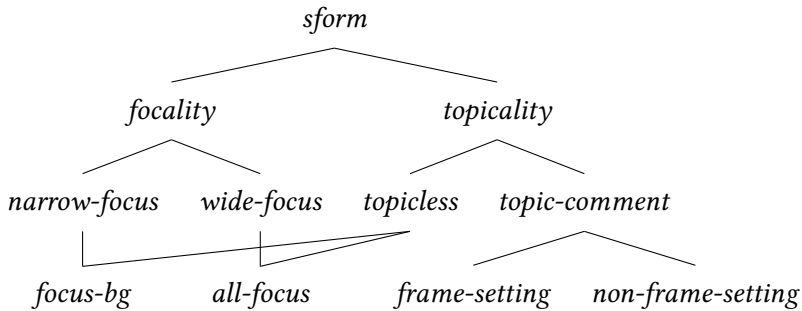
Figure 17.4: Type hierarchy of *sform* (Song 2017: 125)

I assume that Bildhauer & Cook’s (2010) *a-topic-comment* can be directly translated into Song’s (2017) *non-frame-setting*, and propose the following constraint:

$$(17.6) \quad \left[ \begin{array}{l} \textit{non-frame-setting} \\ \text{CAT|HEAD|DT} \langle [\text{INDEX } \bar{i}] \rangle \\ \text{CONT|HOOK} \quad [\text{CLAUSE-KEY } \bar{e}] \end{array} \right] \Rightarrow \left[ \text{C-CONT|ICONS} \left\langle \left[ \begin{array}{l} \textit{aboutness-topic} \\ \text{TARGET } \bar{i} \\ \text{CLAUSE } \bar{e} \end{array} \right] \right\rangle \right]$$

The implication in (17.6) is that if an AVM has the type *non-frame-setting*, then the Designated Topic is the topic of the clause (i.e. an appropriate TARGET-CLAUSE pair with the status *aboutness-topic* is introduced in the construction).<sup>5</sup>

### 17.3 Formalization of the Focus-Background Conflict constraint in HPSG

Recall that in Song’s terminology, “background” applies to the elements in the utterance that are neither topic nor focus (Figure 16.25). In my terminology so far, and in the formulation of the FBC constraint in particular, I assumed that the topic belongs to the background (Section 4.1). In order to match Song’s terminology, the constraint (15.1) can be reformulated as: “A focused element should not be part of a non-focus constituent.”

Another way to formulate this is to say that all dependents of a non-focus word should be non-focus as well, which is exactly the meaning of the (simplified) formalization in Figure 17.5.

<sup>5</sup>Recall that the Discourse-clash Avoidance Principle (16.18) ensures that an element can have only one discourse status with respect to a clause. It follows that *info-str* element introduced by the Designated Topic must match the one introduced by the construction *non-frame-setting*, except if the element has a discourse status with respect to two or more different clauses.

$$\begin{aligned} & \left[ \begin{array}{l} \text{word} \\ \text{SYNSEM|LOC} \left[ \begin{array}{l} \text{CAT|HEAD} \quad \text{non-verbal} \\ \text{CONT|HOOK} \left[ \begin{array}{l} \text{ICONS-KEY} \quad \text{non-focus} \\ \text{CLAUSE-KEY} \quad \boxed{e} \end{array} \right] \end{array} \right] \end{array} \right] \right] \\ \Rightarrow & \left[ \text{ARG-STR} \left\langle \dots \left[ \begin{array}{l} \text{non-focus} \\ \text{CLAUSE KEY} \quad \boxed{e} \end{array} \right] \dots \right\rangle \right] \end{aligned}$$

Figure 17.5: Focus-Background Conflict constraint (simplified)

The implication in Figure 17.5 should be understood as follows: a non-verbal word that has non-focus status with respect to a certain clause can only subcategorize for elements that are also non-focus with respect to the same clause.

This applies to all parts of speech except *verbal*: As discussed in Chapter 15, a verbal element can have non-focus status without constraining its arguments to have non-focus status as well. Complementizers, on the other hand, are semantically empty, and are therefore not affected by the FBC constraint.

A non-focus noun, for example a topic subject NP as in (17.7), can only have non-focus complements, otherwise it would violate the Focus-Background Conflict constraint (Figure 17.5). This is illustrated by Figure 17.6.

- (17.7) # [l' originalité [de cette innovation]<sub>F</sub>]<sub>T</sub>  
the uniqueness of this innovation  
‘the uniqueness of this innovation’

### 17.3.1 Implementing the FBC constraint

The formalization in Figure 17.5 is sufficient for my demonstration, but it would be insufficient for a direct implementation. Technically, we need to make sure that the ARG-STR list only contains *info-str* elements that are non-focus with respect to the clause  $\boxed{e}$ , while allowing any other *icons* element that is not of the type *info-str*, and also potentially allowing *info-str* elements that are non-focus with respect to another clause. This point is crudely represented by the dots in Figure 17.5.

For the reader interested in the technical details of implementing the constraint, here is a method in two steps. First, we can define a function `non-focus()` that takes as arguments an event and a list of objects of the type *info-str*:

(17.8) `non-focus( $\boxed{1}$ ,  $\boxed{2}$  [ info-str | Rest ] : -`  
`[ CLAUSE  $\boxed{3}$  ]`

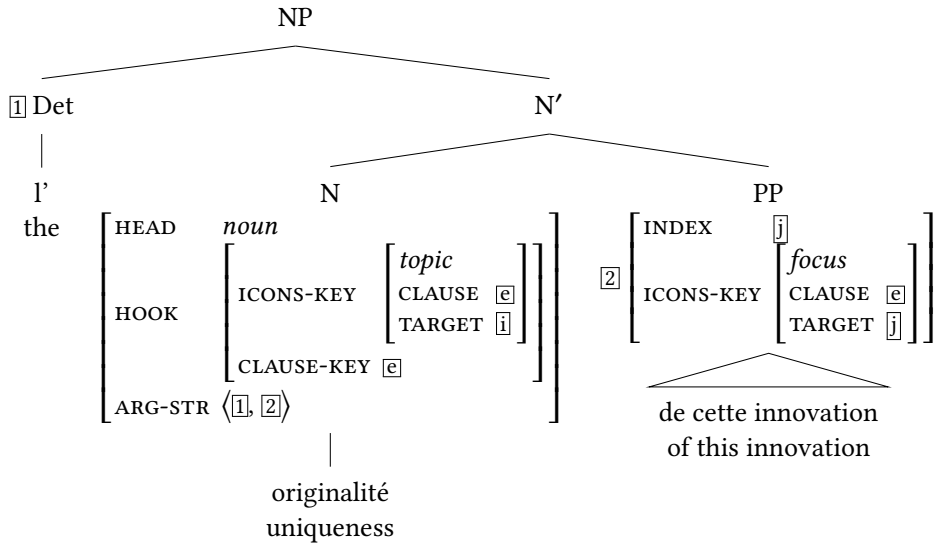

Figure 17.6: Simplified tree for the infelicitous NP “l’ originalité [de cette innovation]<sub>F</sub>]<sub>T</sub>” (‘the uniqueness of this innovation’)

if  $\boxed{1} == \boxed{3}$ , then  $\boxed{2}$ [*non-focus*] and *non-focus*( $\boxed{1}$ , Rest) .  
*non-focus*( $\boxed{1}$ ,  $\langle \rangle$ ) .

The function *non-focus*() checks whether the *CLAUSE* value of the first *info-str* object of its second argument is identical with its first argument, and if so, constrains the *info-str* object to be *non-focus*. It then recursively checks each element of the list until the end in the same way.

Second, we may reformulate Figure 17.5 as Figure 17.7.

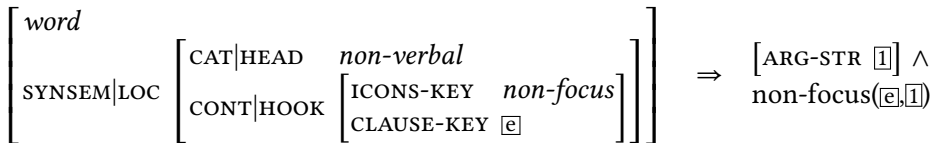

Figure 17.7: Focus-Background Conflict constraint

I will now consider how the FBC constraint interacts with each of the following constructions: interrogatives, *c’est*-clefts and relative clauses.



### 17.3.2 The FBC constraint in interrogatives

In standard interrogatives with extraction of the *wh*-word (*standard-wh-inter-cl*), the filler receives a *semantic-focus* interpretation, see (16.30). For a sentence like (17.9), with extraction out of the subject, the consequence is that the Designated Topic cannot be the topic of the utterance as defined in (17.6), because then it would violate the rule in Figure 17.5.

- (17.9) [De quelle innovation]<sub>i</sub> [l' originalité <sub>-i</sub>] enthousiasme-t-elle mes  
of which innovation the uniqueness excites-0-3SG.SBJ.FEM my  
collègues?  
colleagues  
‘Of which innovation does the uniqueness excite my colleagues?’

In extraction out of the subject in an interrogative, the subject cannot be topic, i.e. either another element is topic (*frame-setting-topic*) or the clause is *topic-less*. For example, Chaves shows that example (17.10) is acceptable in English. In Abeillé et al. (2020), we use a test for topicality in order to show that the clause has an all-focus interpretation, see (17.11).

- (17.10) (Chaves 2013: 313)  
Which problem will [the solution to <sub>-</sub>] never be found?
- (17.11) a. A solution to this problem will never be found.  
b. # Speaking of a solution to this problem, it will never be found.

Figure 17.8 shows the analysis of such a case. In this example, the sentence in (17.9) is all-focus, as in (17.10).

On the other hand, if the filler is not focused, as in rhetorical questions, then the extraction is felicitous, as in example (11.9) reproduced in (17.12).

- (17.12) [De quel pays]<sub>i</sub> [la dépense militaire <sub>-i</sub>] dépasse annuellement  
of which country the budget military exceeds yearly  
mille milliards de dollars [...] ?  
thousand billion of dollars  
‘Of which country does the military budget exceed yearly 1000 B.  
dollars?’

Notice that the constraint predicts that in languages in which postverbal subjects are focused, interrogatives with extraction out of postverbal subjects should

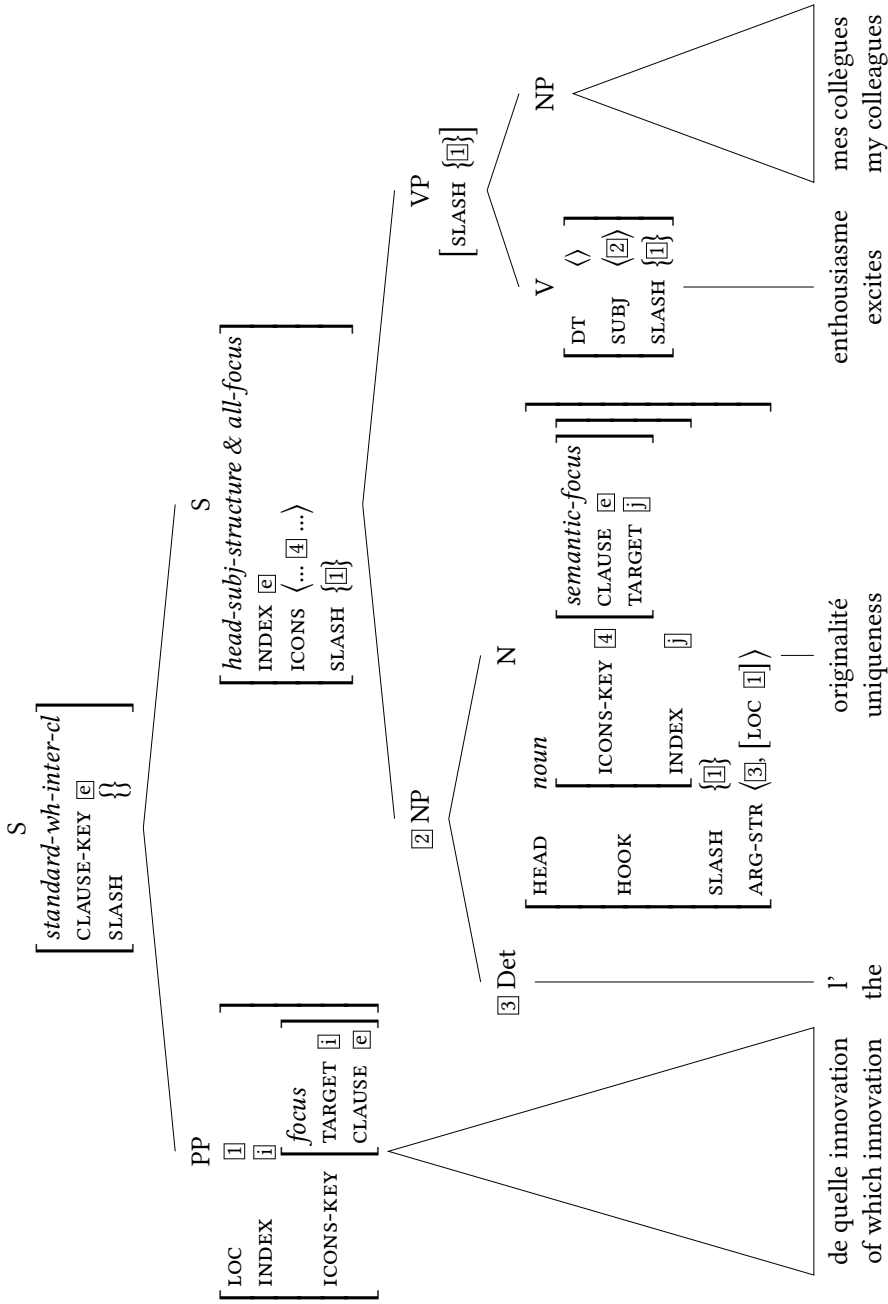

Figure 17.8: Simplified tree for [De quelle innovation]<sub>i</sub> [l'originalité -i] enthousiasme-t-elle mes collègues? ('Of which innovation does the uniqueness excite my colleagues?')

be more felicitous than extraction out of preverbal subjects. Spanish, for example, is such a language.

As such, the constraint in Figure 17.5 predicts that an interrogative with extraction out of the subject in a long-distance dependency is felicitous. A *standard-wh-cl* constrains the filler from bearing focus with respect to the main clause (the HEAD-DTR), see (16.30). In this case, the value of the embedded subject's ICONS-KEY|CLAUSE does not match the value of the filler's ICONS-KEY|CLAUSE, and Figure 17.5 is not violated. And indeed, I argued in Section 15.2 that I do not have evidence that focalization involving a long-distance dependency violates the FBC constraint.

Figure 17.9 illustrates the HPSG analysis for an interrogative with long-distance dependency in which the filler is focus and the subject of the embedded clause topic. There is no violation of Figure 17.5.

- (17.13) [De quelle innovation]<sub>i</sub> suppose-t-il [que [l' of which innovation supposes-0-3SG.SBJ.MASC that the originalité <sub>-i</sub>] enthousiasme mes collègues] ?  
 uniqueness excites my colleagues  
 'Of which innovation does he suppose that the uniqueness excites my colleagues?'

### 17.3.3 The FBC constraint in *c'est*-clefts

The FBC constraint makes the same predictions for *it*-clefts as for interrogatives involving focalization. Figure 17.10 shows a case of *c'est*-clefts with extraction out of a subject. Even though it is extraction out of a sentential complement, the structure is monoclausal and the subject cannot be topic, otherwise Figure 17.5 would be violated.

- (17.14) C' est [de cette innovation]<sub>i</sub> [que [l' originalité <sub>-i</sub>] enthousiasme  
 it is of this innovation that the uniqueness excites  
 mes collègues].  
 my colleagues  
 'It's of this innovation that the uniqueness excites my colleagues.'

Notice that an interrogative with extraction out of the pivot is expected to be felicitous under the FBC constraint: the pivot is focused and so is the *wh*-phrase, therefore there is no discourse clash.

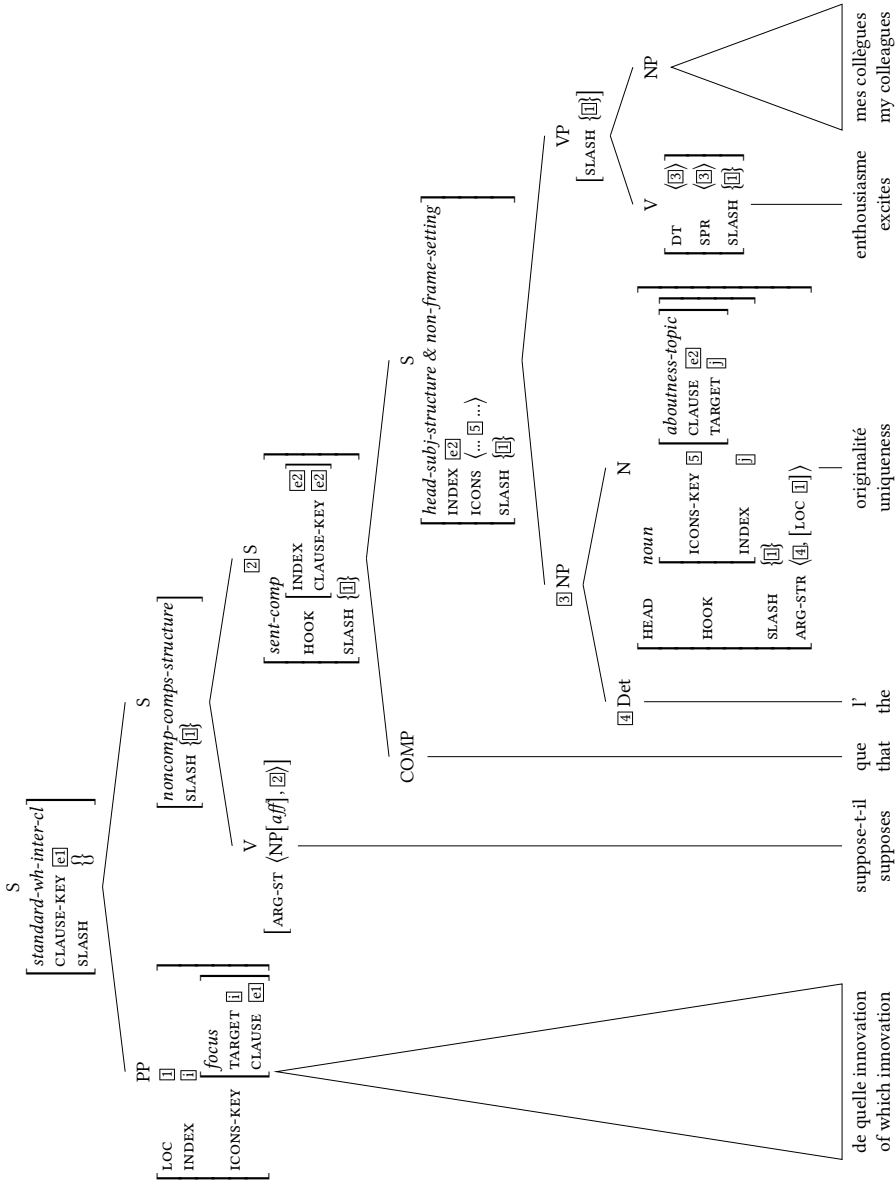

Figure 17.9: Simplified tree for [De quelle innovation]<sub>i</sub> suppose-t-il [que [l'originalité -<sub>i</sub>] enthousiasme mes collègues]? ('Of which innovation does he suppose that the uniqueness excites my colleagues?')



- (17.15) a. [Which car]<sub>i</sub> is it [the color of <sub>-i</sub>]<sub>j</sub> that you loved <sub>-j</sub> most?  
 b. [De quelle innovation]<sub>i</sub> est - ce [l' originalité <sub>-i</sub>]<sub>j</sub> que mes  
 of which innovation is it the uniqueness that my  
 collègues apprécient <sub>-j</sub> ?  
 colleagues appreciate  
 'Of which innovation is it the uniqueness that my colleagues  
 appreciate?'

Extraction out of the *que*-clause falls under the same constraints as any extraction in a long-distance dependency. An interrogative involving extraction out of the subject would not violate Figure 17.5. Relativization out of the *que*-clause is also expected to be felicitous.

### 17.3.4 The FBC constraint in relatives

Finally, the FBC constraint has no impact on relative clauses. Figure 17.11 on page 467 illustrates relativization out of a topic subject in a *comp-rel-cl* (with a complementizer). In this case, the slashed element is never realized; its INDEX value is only structure-shared with the INDEX value of the noun modified by the relative clause. The implication in Figure 17.5 constrains the ICONS-KEY value of the slashed element to be *non-focus*, but it is completely underspecified in other respects.

- (17.16) une innovation [dont<sub>i</sub> [l' originalité <sub>-i</sub>] enthousiasme mes  
 an innovation of.which the uniqueness excites my  
 collègues]  
 colleagues  
 'an innovation of which the uniqueness excites my colleagues'

Figure 17.12 on page 468 illustrates extraction out of the topic subject of a *wh-rel-cl* (with pronominal filler). In this particular example, given in (17.17), the filler is [P + pronoun]. The FBC constraint does not constrain the elements of the ARG-ST list, because relative pronouns are informatively empty (Song 2017: 112) and therefore their ICONS-KEY value is *i-empty*.

- (17.17) un avocat [[de qui]<sub>i</sub> [l' associé <sub>-i</sub>] aide mon cousin]  
 a lawyer of who the associate helps my cousin  
 'a lawyer of whom the associate helps my cousin'



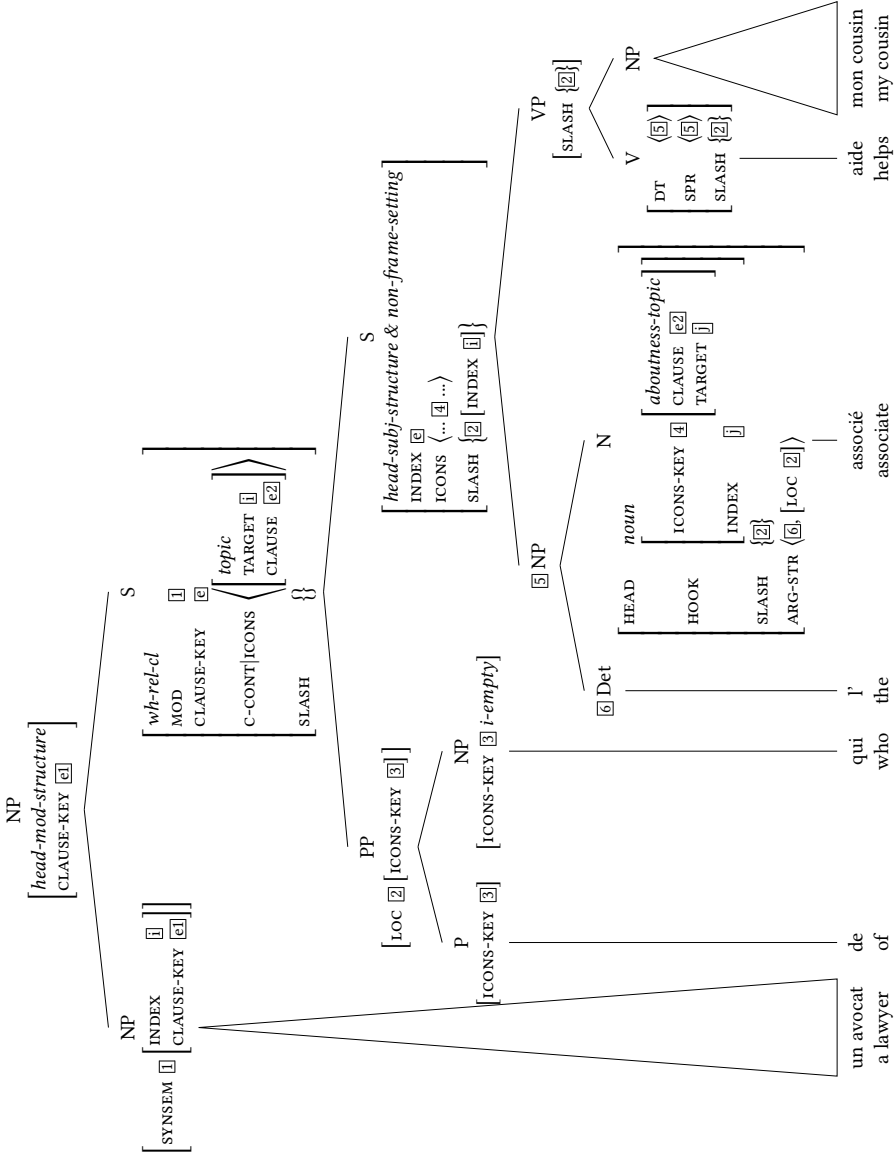

Figure 17.12: Simplified tree for *un avocat* [[*de qui*]<sub>i</sub> [*l'associé* →<sub>j</sub>] *aide mon cousin*] ('a lawyer of who the associate helps my cousin')



### 17.3 Formalization of the Focus-Background Conflict constraint in HPSG

Another case of extraction out of the topic subject of a *wh-rel-cl* is illustrated by Figure 17.13 on page 470. Here, the relative pronoun is embedded in an NP, and the *ICONS-KEY* value of the filler is constrained by the implication in Figure 17.5 to be *non-focus*. It is otherwise underspecified.

- (17.18) Christelle, [[de la soeur de qui]<sub>i</sub> [l' arrogance <sub>-i</sub>] rebute mes  
Christelle of the sister of who the arrogance repels my  
collègues]  
colleagues  
'Christelle, whose sister's arrogance repels my colleagues'

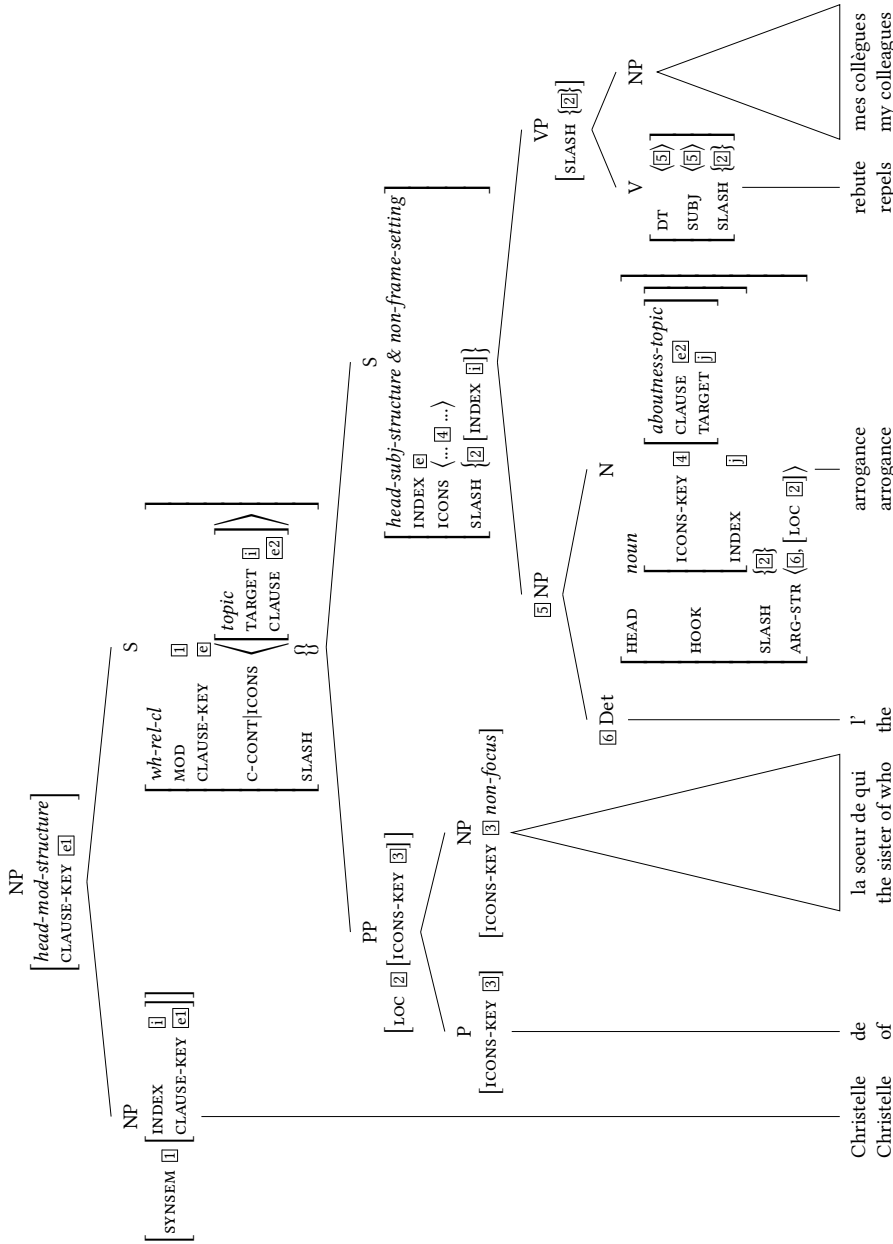

Figure 17.13: Simplified tree for *Christelle*, [[*de la soeur de qui*]<sub>i</sub> [*l'arrogance -i*] *rebute mes collègues*] ('Christelle, whose sister's arrogance repels my colleagues')

## 18 Extraction out of infinitival and sentential subjects

Infinitival and sentential subjects receive a simple analysis in HPSG, and there is not much HPSG literature about them. Their impersonal variants like (18.1) have attracted more attention.

(18.1) (example from COCA cited by Lee 2018: 72)

It was assumed [that the teachers answered all written and oral questions honestly].

As previously said in Section 16.2.5, I assume that sentential and infinitival subjects are licensed for some verbs, similarly to sentential and infinitival complements, as is commonly assumed in HPSG. A lexical rule allows NP elements in ARG-ST to be an S or a VP when the element may refer to a situation or an event. The subject of *bark*, for example, cannot be sentential nor infinitival, but the subject of *annoy* can. Sentential subjects are finite (S [MARKING *que*]) and infinitival subjects are non-finite (VP [VFORM *infinitive*]).

In Section 14.2.3, I have argued – based on the results of Experiments 15 and 16 and following Kluender’s (2004) proposal – that the effects observed in relativizing out of infinitival subjects may be best explained by processing factors. Overall, the experiments show that native speakers do not strongly reject these relativizations. The specificity of the filler, the complexity of the subject and probably many other intervening factors play a role in the finding that some extractions out of verbal subjects are very unnatural, and therefore received degraded acceptability judgments. Sentential subjects and infinitival subjects are not common: in French, they are very rare in the corpora (Abeillé et al. (2019) found only 24 sentential subjects and 99 infinitival subjects in the French Treebank; Berard (2012: 153) found in her corpora only complex NPs and no sentential or infinitival subject). Sentential subjects are harder to process than sentential complements (Frazier et al. 1988) and seem to require pragmatic licensing (according to Miller (2001: 685), English sentential subjects are only felicitous if their content is “discourse-old or inferrable”). My HPSG proposal does not account for these effects and licenses extraction out of sentential subjects. Hence, there is no constraint on the SLASH set of sentential and infinitival subjects.

## 18.1 Sentential subjects

Erteschik-Shir (1973) has shown that sentential subjects are backgrounded – i.e. *non-focus* – with respect to the main clause (see also later Goldberg 2006). Similarly, Lee (2018) claims that the way to focalize the sentential subject in English is to turn it into a sentential complement in an impersonal construction like (18.1).

Hence, the lexical rule which allows NP elements in ARG-ST to be an S [MARKING *que*] also assigns a *non-focus* value to the embedded clause with respect to the embedding clause whenever it is the subject. This rule may lead to Figure 18.1 for the verb *agacer* (‘to annoy’).

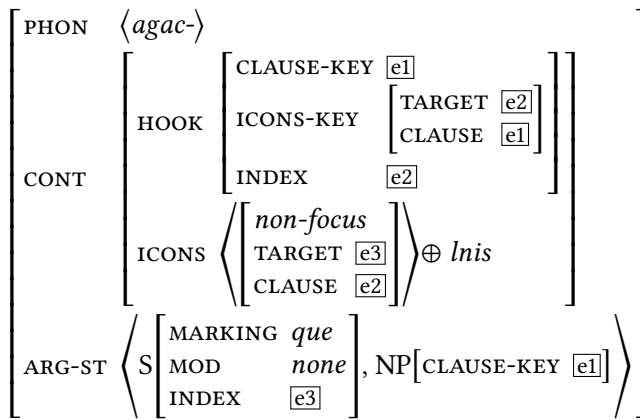

Figure 18.1: Lexical item for *agacer* (‘to annoy’) with sentential subject

The FBC constraint in Figure 17.5 makes no particular prediction with respect to sentential subjects, because it does not apply to *verbal* heads. Still, extraction out of the sentential subject seems less felicitous in interrogatives and *it*-clefts than in relative clauses. Example (18.2b) is an interrogative with extraction out of the sentential subject of (18.2a).

- (18.2) a. [Que Kim parle à Frank] agaçait Lee.  
           that Kim talked.SUBJ at Frank annoyed Lee  
           ‘That Kim talked to Frank annoyed Lee.’
- b. \* À qui [que Kim parle \_] agaçait Lee?  
       at who that Kim talked.SUBJ annoyed Lee  
       ‘Who did that Kim talked to annoy Lee?’ (intended: Who did it  
       annoy Lee that Kim talked to?)

The reason why (18.2b) is degraded has probably nothing to do with the FBC constraint. Davies & Dubinsky (2009) argue that such extractions may be difficult because they are a case of center-embedding. Center-embedded structures, albeit grammatical, are very difficult to parse. Fodor et al. (2017) observe that typical center-embedded sentences become more acceptable with the right prosody, as in (18.3a) where || indicates that a pause is inserted. It would be interesting to see if similar results can be achieved on sentences like (18.2b). Chaves (2012) shows that it is at least the case for extractions out of subject NPs.

- (18.3) a. (Fodor et al. 2017: ex. 11)  
 The elegant woman || that the man I love met || moved to  
 Barcelona.
- b. (Chaves 2012: ex. 56a)  
 Which book || did a review of || appear in the Times?

Example (18.4) is a *c'est*-cleft with extraction out of the sentential subject of (18.2a). It is also unacceptable.

- (18.4) \* *C' est à Frank [que [que Kim parle \_] agaçait Lee].*  
 it is at Frank that that Kim talked.SUBJ annoyed Lee  
 'It's Frank that that Kim talked to annoyed Lee.' (intended: It's Frank  
 that it annoyed Lee that Kim talked to.)

In this case, the reason is probably a general ban on repeating the complementizer, which is probably ruled out for processing reasons as well. For example, a sentential subject cannot contain a sentential subject, as in (18.5).

- (18.5) a. \* [That [that Kim was late] annoyed Lee] is not a secret.
- b. \* [Que [Que Kim parle à Frank] agaçait Lee] était connu  
 that that Kim talked.SUBJ at Frank annoyed Lee was known  
 de tous.  
 of all  
 'That that Kim talked to Frank annoyed Lee was known by all.'  
 (intended: It was know by all that it annoyed Lee that Kim talked  
 to Frank)

Therefore, this problem has nothing to do with extraction. It is also not restricted to sentential subjects, as shown by (18.6).

- (18.6) ?? I understood [that [that Kim was late] annoyed Lee].

## 18.2 Infinitival subject

Infinitival arguments are defined as VP, hence they are not independent clauses as far as information structure is concerned. As explained earlier, they share the value of their `CLAUSE-KEY` feature with the value of the `CLAUSE-KEY` feature of the embedding verb, like NP arguments (in contrast to sentential complements, which form a clause and whose `CLAUSE-KEY` value is not structure-shared with the one of the embedding verb). Compare the lexical entry in Figure 18.1 with the lexical entry in Figure 18.2.

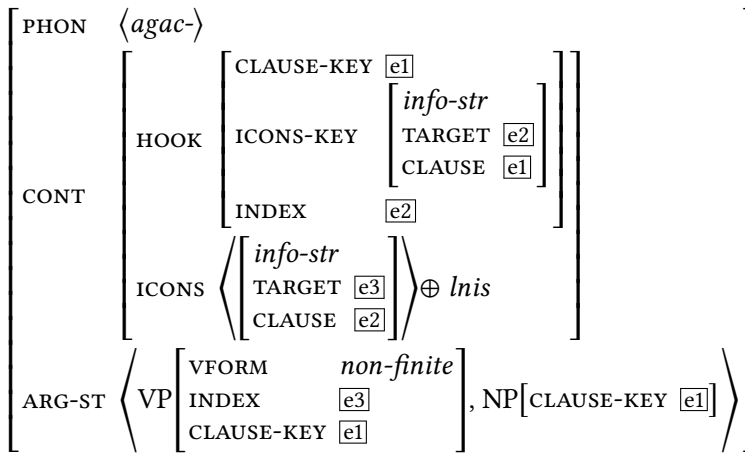

Figure 18.2: Lexical entry for *agacer* ('to annoy') with infinitival subject

Figure 18.3 illustrates the HPSG analysis of a relative clause with a relative pronoun that contains extraction out of the infinitival subject. An interrogative would be similar, except for the information structure of the filler, which would be *focus*. Focalizing part of a *non-focus* infinitival subject is not restricted by the FBC constraint, because the infinitival subject has the feature  $[\text{HEAD } \textit{verb}]$ . Figure 18.4 on page 476 shows the HPSG analysis of a relative clause with a complementizer that contains extraction out of an infinitival subject.

- (18.7) a. Amsterdam, [où<sub>i</sub> [flâner -<sub>i</sub>] est charmant]  
 Amsterdam where wander.INF is charming  
 'Amsterdam, where wandering is charming'
- b. Amsterdam, [qu<sub>i</sub>' [observer -<sub>i</sub>] est charmant]  
 Amsterdam that observe.INF is charming  
 'Amsterdam, observing which is charming'

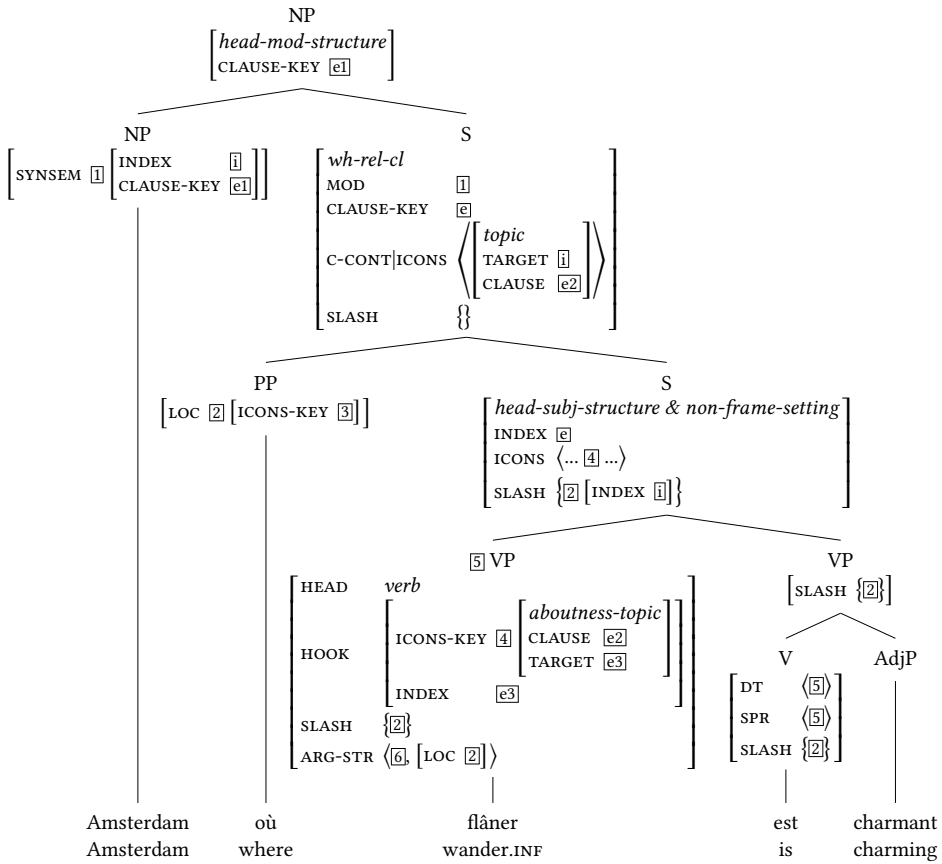

Figure 18.3: Simplified tree for *Amsterdam*, [*où<sub>i</sub> [flâner<sub>-i</sub>] est charmant*] ('Amsterdam, where wandering is charming')

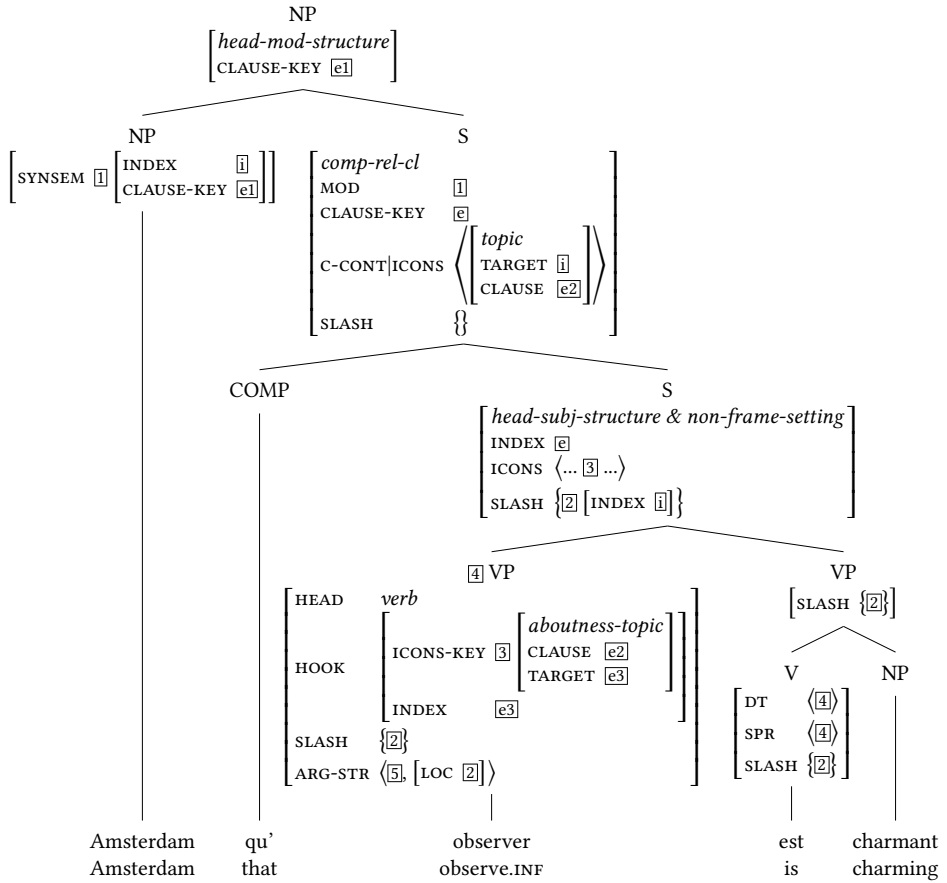

Figure 18.4: Simplified tree for *Amsterdam, [qu<sub>i</sub>'[observer -<sub>i</sub>] est charmant]* ('Amsterdam, that observing is charming')



## 19 Conclusion

In this last part, I discussed in more detail the FBC constraint and its implications, and proposed a formal analysis in HPSG. In the process, I sketched a substantial fragment of a French grammar in HPSG. I showed a cross-classification of interrogatives (inspired by Ginzburg & Sag 2000) and of relative clauses (based on Abeillé & Godard 2007), while *c'est*-clefts are formed by specific lexical entries of *être* ('be') (Winckel & Abeillé 2020). I explained how information structure interacts with syntax in these short- and long-distance dependencies. The impression of a “subject island” in focalizing constructions arises from the fact that subjects are preferred topics for the majority of verbs. I modeled this preference by treating subjects of such verbs as the DESIGNATED TOPIC, following a proposal by Bildhauer & Cook (2010). This allowed me to then propose a formalization of the FBC constraint (17.5).

When reflecting on all this evidence showing the non-existence of subject islands, one cannot help but ask why so many linguists have postulated a subject island constraint. I suppose it is possible to see this as a consequence of the fact that most of the examples on which the discussion was based were interrogatives, as were most of the previous experiments.

One major element is missing in my HPSG analysis. In Section 15.1, I emphasized that the FBC constraint presupposes gradient information structure. Besides Webelhuth's (2007) “more thematic than” function (which, I think, is not compatible with Song's (2017) representation of information structure), there has been no attempt in HPSG to capture this gradience. As the goal of the present work was not to determine how and why an element is more or less focus, topic or backgrounded, it can therefore not contribute much to constructing such a model. However, presumably several factors contribute to making an element more or less focused, topicalized or backgrounded. For example, the topic of an embedded clause may be less topical than the topic of the embedding clause. It would then follow that the FBC constraint applies less strongly to elements that are less backgrounded, and this could explain why we do not see superadditive effects in the interrogatives with long-distance dependencies. For the time being, this is unfortunately only speculation. Once the factors have been identified, it should be possible to treat them as weighted constraints and attempt to model

## 19 Conclusion

the gradience of information structure. Some proposals have been made to introduce weighted constraints in HPSG (in the *Verbmobil* project (Müller & Kasper 2000), in Brew (1995), in Guzmán Naranjo (2015), or in An (2020), see Müller (2017: 164)), but their aim was to compute probabilistic models of sentence processing (production and comprehension) – for example the probability of using one or the other dative construction for ditransitive verbs in English (*give Sandra the book / give the book to Sandra*). Any effort to adapt these methods and propose a new way to treat information structure as a gradient feature instead of a categorical feature on lexical signs would contribute greatly to the scientific debate. However, such an attempt goes far beyond the scope of this work.

## **Part IV**

# **Concluding remarks**



## 20 Concluding remarks

The present work aimed to contribute to the current debate on subextraction from subjects in French. Subjects have often been considered to be “island” environments, so in the first part of the book I discussed ways to define islands and the classification of sentential subjects and subjects in general as islands. I also presented a state of the art identifying three main directions in accounting for the phenomenon: syntax-based approaches (often defended by Minimalists, but also by researchers working in other frameworks, as well as in the early HPSG analyses), processing-based approaches and discourse-based approaches. The focus of this book is on a discourse-based hypothesis that I presented with some colleagues in Abeillé et al. (2020) and called the Focus-Background Conflict (FBC) constraint. The FBC constraint states that part of a background cannot be focused.

I have shown that there is disagreement on the data where subextraction out of the subject is concerned: Is it ungrammatical or only degraded? Are the constraints cross-linguistically valid? Do they apply in all constructions? Are all subjects affected by the same constraints? Working on French, where the data have been particularly debated (a.o. Godard 1988, Tellier 1991, Heck 2009), I gathered empirical evidence that enabled me to answer these questions at least partially.

In the second part of this work, I presented the results of eight corpus studies and 16 experiments.

The corpus studies show that extraction out of the subject is very common in relative clauses. In fact it is the most common usage with the complementizer *dont* (‘of which’). Long-distance dependencies are attested as well, which shows that *dont* relative clauses involve extraction, contrary to a proposal made by Heck (2009). Relativization out of the subject with *de qui* (‘of who’) is common, contrary to Tellier’s (1991) claims, and so is relativization out of the subject with *duquel* (‘of the which’). Relativization out of the subject with *avec qu-* (‘with *wh-*’) is not very common, but attested. The important finding of my corpus studies is that there is no attested extraction out of the subject in interrogatives. Because interrogatives, unlike relative clauses, are focusing constructions, I argue that these findings are in line with the FBC constraint, while the cross-construction difference is unexpected under the other hypotheses.

The experiments tested extraction out of the subject on different constructions (relative clauses, interrogatives, *it*-clefts), and compared it with extraction out of the direct object. All experiments on relative clauses show that extraction out of the subject is not degraded compared to extraction out of the object: it receives similar or even higher acceptability ratings and does not cause a slow-down during reading. In interrogatives with short-distance dependencies, ratings for extraction out of the subject are lower than for extraction out of the object, but only in *wh*-questions and not in questions with *wh* in situ. Furthermore, extraction out of the subject in long-distance dependencies does not show a significant decrease of acceptability. In *it*-clefts, there is a tendency such that extraction out of the subject receives lower ratings than extraction out of the object. Since interrogatives and *it*-clefts are focalizing constructions, unlike relative clauses, the FBC constraint seems to capture the results quite well.

Finally, I presented a formalization of the FBC constraint. I clarified some details about the FBC constraint, especially the way it applies to long-distance dependencies and *it*-clefts. Then I proposed a formalization of the FBC constraint in HPSG. For this, I sketched the basis for a French HPSG fragment in which I adopt Song's (2017) representation of information structure in MRS objects (Copestake et al. 2005). The FBC constraint states that parts of a non-focus element (elements in its ARG-STR list) must be non-focus as well. Extraction out of the subject in interrogatives and clefts is therefore not ruled out, but must have a specific interpretation. Extraction out of the subject in relative clauses is not constrained by the FBC, because the extracted element is non-focus.

Throughout the present work, while emphasizing the impact of the FBC constraint, I also said that many factors are at play in extraction, and that non-discourse factors such as the complexity of the subject, the length of the dependency, the number of gaps or the familiarity with the structure (habituation) are all important. Therefore, I am not claiming that the FBC constraint by itself completely accounts for what is called the "subject island". On the other hand, the formulation of the constraint clearly implies that it is not restricted to extraction (let alone to subextraction from the subject). It may, therefore, offer explanatory potential far beyond the scope I identified in this book.

I leave for future research the task to see in which respect the FBC constraint is able to account for other structures identified as "islands" in the literature. For example, restrictive relative clauses are presupposed and as such fall under by the FBC constraint. Relative clauses are claimed to be islands to extraction, but there has been no report of a difference between relative clauses and interrogatives. Similarly, complements of factive verbs are claimed to be islands to extraction.

Ambridge & Goldberg (2008) explain the contrast between bridge verbs and factive verbs through backgroundedness. Example (20.1) shows that extraction out of the complement of bridge verbs (20.1a) is more acceptable than extraction out of the complement of factive verbs (20.1b).

- (20.1) a. (Ambridge & Goldberg 2008: 371)  
What did Jess think that Dan liked?  
b. ? What did Jess know that Dan liked?

According to Liu et al. (2019), the acceptability of subextraction from a sentential complement is better explained by the frequency of the introducing verb than by the propositional status of the sentential complement, but they tested only interrogatives. In these two cases alone, the FBC constraint could be shown by future research to explain previously ill-understood problems in linguistics.

Even though my focus in this book was on French, there are strong reasons to expect that the FBC constraint applies cross-linguistically. If we assume that it is a reflection in the language of a more general principle of cognitive attention, then it should have an impact in any language. However, languages seem to differ in their sensitivity to the constraint as far as extraction out of the subject is concerned. In French interrogatives, subextraction from the subject is rated clearly higher than ungrammatical controls. In parallel experiments on English, however, extraction out of the subject receives ratings that are not significantly higher than ungrammatical controls (Abeillé et al. 2020: third experiment). By contrast, subextraction from the subject in Japanese is claimed to be acceptable in all constructions (a.o. Ross 1967, Kuno 1972, Kayne 1983, Stepanov 2007).<sup>1</sup> More research is needed in order to see what may cause these cross-linguistic differences, and why languages seem to be more or less constrained by the FBC. This may be related to how information structure manifests itself in these languages.

From a methodological point of view, the present work has shown that linguistic research can greatly profit from carefully conducted corpus studies and experiments. This is not to say that intuitive judgments are necessarily unworthy. In fact, on many occasions I was able to confirm or explain linguists' intuitions. The problem comes from a misinterpretation of these intuitions. Some contrasts

---

<sup>1</sup>Notice that extraction out of relatives is supposed to be acceptable in Japanese as well.

(i) (Kuno 1987: 15)

Kore wa [[\_ kawaiatte ita] neko ga sinde simatta] kawaiiso na kodomo desu.  
this loved cat died poor child is  
'This is a poor child who the cat that (he) loved died.'

may not receive the attention they deserve, as for example the contrast between extraction out of the subject in interrogatives and in relative clauses, which was mentioned in early works (Chomsky 1973: 32) but hardly ever addressed afterwards. On the other hand, some contrasts may be considered by scholars to be more important than they actually are, and we can often observe a tendency to overgenerate an observation. For example, the contrast between extraction out of the subject with *dont* vs. *de qui* in French asserted by Tellier (1991) has some grounds, but it seems to come from a general preference for subextraction out of NPs with *dont* and not from a problem specific to subextraction from subjects. A preference for extraction out of subjects of passives over extraction out of subjects of transitives can also be explained by the fact that transitive verbs tend to have less complex subjects, but this does not mean that subjects of passives are special as far as extraction is concerned. Looking carefully at the corpora and testing different extraction types with the appropriate controls allowed me to clarify some inadequate intuitions while partially explaining where they come from.



## Part V

# Appendices



# Appendix A: Corpus annotation guidelines

In annotating the corpus results presented in Part II of this work, we followed the guidelines below:

- Verb types:
  - *state*: exclusively for the verb *être* ('be')
  - *transitive*: for any verb with a realized direct object, also including transitive verbs whose direct object is realized as a reflexive pronoun (sometimes called 'true reflexives')
  - *mediopassive*: verb with a reflexive; its prototypical form is transitive, but here the prototypical object is the grammatical subject of the verb
  - *passive*
  - *unaccusative*: verb without a realized direct object and building its *participe passé* (past participle) with the auxiliary *être* ('be'); this category also includes verbs with a reflexive that are neither true reflexives nor mediopassive and have a non-agentive subject
  - *unergative*: verb without a realized direct object and building its *participe passé* (past participle) with the auxiliary *avoir* ('have'); this category also includes verbs with a reflexive that are neither true reflexives nor mediopassive and have an agentive subject

For the sake of simplicity, we use the auxiliary to distinguish between unaccusative and unergative verbs (Labelle 1992), except for reflexives (Legendre & Sorace 2003: 206–208). Notice that with this method, the number of unergative verbs may be overestimated (Legendre & Sorace 2003).

- Restrictiveness: Whether a relative clause is restrictive or non-restrictive. We used the following criterion: the relative clause is considered appositive (restrictive = no) if the antecedent is a proper noun or if the relative clause is enclosed between commas; otherwise, it is considered restrictive

## *A Corpus annotation guidelines*

(restrictive = yes). This annotation rule has obvious drawbacks, because the use of commas around a non-restrictive relative clause is not mandatory, but it enabled us to stay as objective as possible while annotating.

## Appendix B: Semantic relations in relative clauses (corpus studies)

In addition to the factors already mentioned in Part II, we annotated the type of semantic relationship between the extracted element and its head. We performed this annotation both for extraction out of the subject and out of the direct object for comparison.

We identified seven different kinds of relations:

- (i) agent or cause, where the extracted element fulfills any kind of proto-agentive role with respect to the (often deverbal) head noun
- (ii) part of whole, the whole being expressed by the head noun
- (iii) patient, where the extracted element fulfills any kind of proto-patient role<sup>1</sup> with respect to the (often deverbal) head noun
- (iv) possession
- (v) quality, where the head noun denotes a quality of the extracted element
- (vi) quantifier, where the extracted element is quantificational with scope over the head noun
- (vii) relational, where the (mostly animate) head noun denotes a social or family relation with respect to the extracted element

The following examples, taken from the corpus studies mentioned above, are examples of extraction out of the subject illustrating these semantic relations.

---

<sup>1</sup>Experiencers are annotated as ‘patient’ (*l’angoisse de Grégoire*, ‘Grégoire’s anxiety’) and so are topics in depicted-topic relations (*la peinture de la Vierge*, ‘the painting of the Virgin Mary’) and information (*la biographie de Françoise Sagan*, ‘the biography of Françoise Sagan’).

*B Semantic relations in relative clauses (corpus studies)*

(B.1) agent/cause:

- a. (FTB - flmf7ah2ep-760)  
l' Afghanistan, dont [la participation \_] avait été  
the Afghanistan of.which the participation had been  
suspendue à la suite de l' invasion soviétique  
suspended at the result of the invasion Soviet  
'Afghanistan, whose participation had been suspended after the  
Soviet invasion'
- b. (Pense à demain, Anne-Marie Garat, 2010)  
un blondinet boutonneux, de qui [le geste \_] l' électrisa  
a blond boy pimply of who the gesture her.ACC electrified  
'the pimply blonde boy, whose gesture electrified her'
- c. (Jean Barois, Roger Martin Du Gard, 1913)  
ceux, du moins, de qui [le jugement \_] garde une activité  
these of least of who the judgment retains an activity  
propre  
own  
'these, at least, whose judgment retains an activity of its own

(B.2) part-whole:

- a. (FTB - flmf7af2ep-559)  
un groupe dont [les unités \_] sont très autonomes  
a group of.which the units are very autonomous  
'a group whose units are very independent'
- b. (Mécanique, François Bon, 2001)  
l' ordinateur de plastique tout neuf, duquel il vous avait  
the computer of plastic all new of.which he you.ACC had  
demandé à quoi servaient [les prises de branchement \_]  
asked at what used the plugs of connection  
'the new plastic computer, of which he had asked you what the  
plugs were for'
- c. (Partage de midi [1re version], Paul Claudel, 1906)  
une danseuse écoutante, dont [les petits pieds jubilants \_]  
a dancer.FEM listening of.which the little feet jubilant  
sont cueillis par la mesure irrésistible !  
are caught by the beat irresistible  
'a listening dancer, whose jubilant little feet are caught by the  
irresistible beat!'

(B.3) patient:

- a. (FTB - flmf3\_03500\_03999ep-3699)  
cette arme dont [la gestion \_] relève du ministère  
this weapon of.which the management belongs of.the Ministry  
de la défense  
of the Defense  
'this weapon whose management belongs to the Ministry of  
Defense'
- b. (Pense à demain, Anne-Marie Garat, 2010)  
Viviane, de qui [l' euphorie \_] augmentait sa tristesse  
Viviane of who the euphoria increased her sadness  
'Vivian, whose euphoria increased her sadness'
- c. (Dans la main du diable, Anne-Marie Garat, 2006)  
Millie, dont grandissait [l' angoisse \_]  
Millie of.which grew the anxiety  
'Millie, whose anxiety was growing'

(B.4) possession:

- a. (FTB - flmf3\_11000\_11499ep-11199)  
American et United, dont [les flottes \_] dépassent les cinq  
American and United of.which the fleets surpass the five  
cents avions  
hundred aircraft  
'American and United, whose fleets contain more than five  
hundred aircrafts'
- b. (L'Île des pingouins, Anatole France, 1908)  
un vieux compagnon d' armes dont [les états de service \_]  
an old comrade of arms of.which the states of service  
étaient superbes  
were superb  
'an old comrade-in-arms whose service record was superb'

(B.5) quality:

- a. (FTB - flmf7am2ep-661)  
l' économie américaine, dont [le poids \_] est lourd  
the economy american of.which the weight is heavy  
'the American economy, whose weight is high'

*B Semantic relations in relative clauses (corpus studies)*

- b. (Le Voyage de Sparte, Maurice Barrès, 1906)  
ce fameux sire de Caritena, de qui [le courage \_], [la  
this famous sire of Caritena of who the courage the  
courtoisie envers les dames \_] et [l' absurde frivolité \_]  
courtesy towards the ladies and the absurd frivolity  
éclatent dans le livre de la conquête publié par Buchon.  
burst in the book of the conquête published by Buchon  
'this famous sire of Caritena whose courage, courtesy towards the  
ladies and absurd frivolity shine through in the book of the  
conquête published by Buchon.'

(B.6) quantifier:

- a. (FTB - flmf7ao1ep-492)  
des journalistes dont [certains \_] ont connu le  
some journalists of.which several have known the  
chômage  
unemployment  
'journalists among which several have experienced  
unemployment'
- b. (Jean-Christophe : La Foire sur la place, Romain Rolland, 1908)  
ses vingt et un enfants, dont [treize \_] moururent avant lui  
his twenty-one children of.which thirteen died before him  
'his twenty-one children, out of which thirteen died before him'

(B.7) relational:

- a. (FTB - flmf7ai2ep-886)  
Banexi und partner, [...] dont bon nombre [de clients \_] sont  
Banexi und partner of.which good amount of clients are  
des petits patrons  
DET small bosses  
'Banexi und partner, of which a good number of the clients own  
small businesses'
- b. (L'enfant des ténèbres, Anne-Marie Garat, 2008)  
Un modeste papetier de qui [l' épouse \_] [...] avait  
a modest papermaker of who the wife had  
constitué le premier rayon d' ouvrages pour dames  
established the first section of books for ladies  
'the modest papermaker, whose wife had set up the first section  
for ladies' books'



- c. (Le corps incertain, Vanessa Gault, 2006)  
 quelqu'un dont [la fille \_] a une copine de classe qui  
 someone of.which the daughter has a friend of class who  
 a une sclérose en plaques  
 has a multiple sclerosis  
 'someone whose daughter has a classmate who has multiple  
 sclerosis'

## B.1 *Dont* relatives in the French Treebank

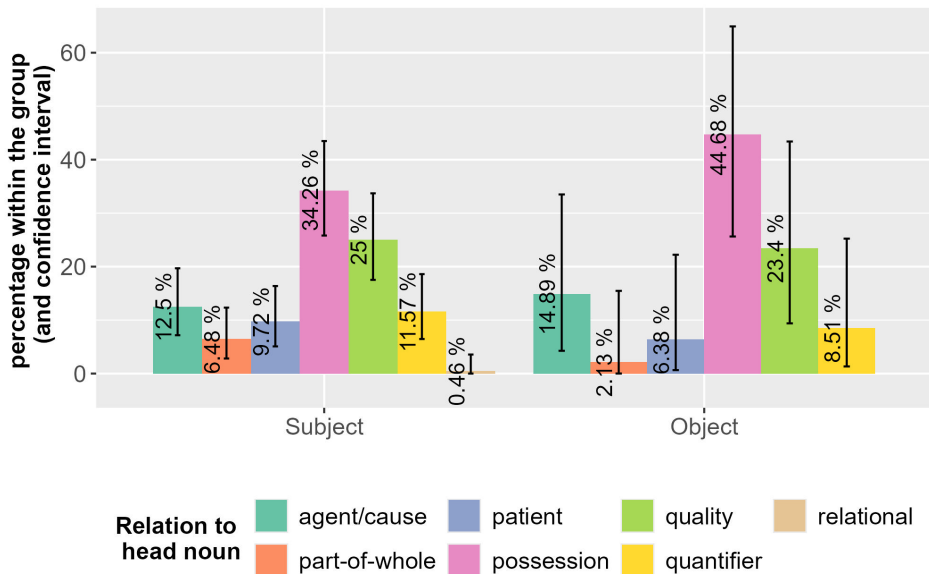

Figure B.1: Semantic relations in *dont* relative clauses in the French Treebank (subject vs. object subextractions). See page 129 for the confidence intervals (here seven comparisons for subject and six for object). The percentage is given for each group (extraction out of the subject vs. extraction out of the object).

Figure B.1 gives the proportion of every category in extraction out of subjects in the FTB, comparing it to extraction out of direct objects as a baseline. The most common kind are *de*-PPs denoting possession in both kinds of extraction. We find almost no relationals (given the confidence intervals, their number is not significantly higher than zero).

## B Semantic relations in relative clauses (corpus studies)

We fitted a logistic regression model predicting the source of extraction (subject = 1; object = 0) for the kind of relation, and we performed a residual diagnostic to test the predictions of the model. The detailed results of the model are given in Table B.1.<sup>2</sup> No category of relation is a good predictor for the variable to be explained, which corroborates what we can see in Figure B.1 (confidence intervals overlap pairwise).

Table B.1: Results of the logistic regression

	Estimate	SE	<i>z</i>	<i>p</i>	Odd.ratio
(Intercept)	1.350	0.424	3.1827	0.0015	3.86
part-whole	1.289	1.119	1.1524	0.2491	3.63
patient	0.596	0.749	0.7958	0.4261	1.81
possession	-0.090	0.491	-0.1841	0.8539	1.09
quality	0.241	0.538	0.4484	0.6539	1.27
quantifier	0.483	0.685	0.7041	0.4814	1.62
relational	13.216	882.744	0.0150	0.9881	549135.22

We can therefore say that in this corpus, no semantic relation type seems to increase or decrease the ability to form an extraction out of the subject. But some semantic relation types are more common than others (although we cannot say whether this is due to the extraction).

## B.2 *Dont* relatives in Frantext 2000–2013

Figure B.2 gives the proportion of every category in extraction out of subjects in Frantext 2000–2013, comparing it to extraction out of direct objects as a baseline. Part-whole is the most common relation in extraction out of the subject, agent and patient are equally the most common in extraction out of the object. While there is almost no relational in the FTB (see above), 10% of the extractions out of the subject are relational subject nouns in Frantext 2000–2013. In extraction out of the subject, the frequency of the categories patient and quantifier is not significantly different from zero. In extraction out of the object, there are no

<sup>2</sup>Validation of the model: The regression model is valid iff the number of data points is at least equal to 5 times the number of explanatory variables. Here, it must be at least equal to 35, and there are 263 data points. Furthermore, the residual diagnostics are compelling. The model is therefore valid.

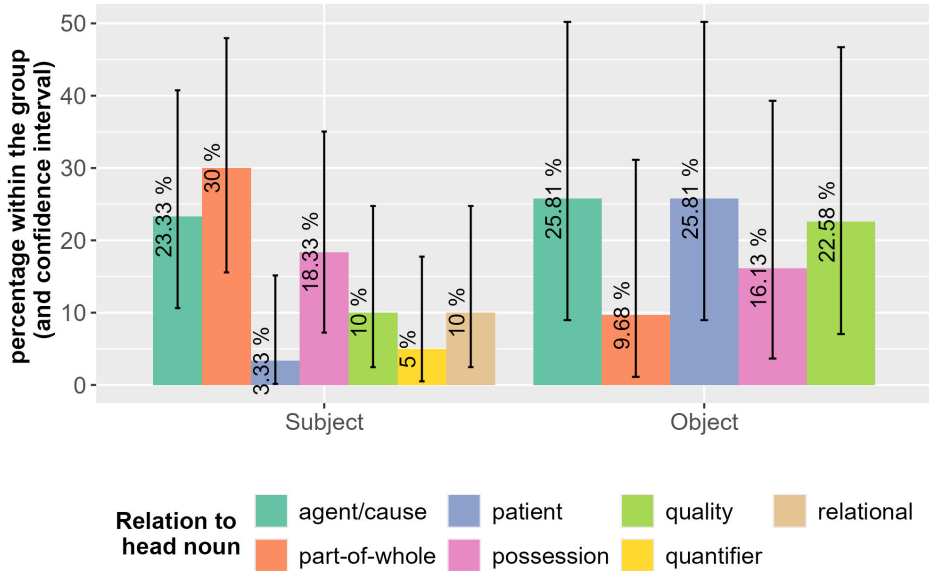

Figure B.2: Semantic relations in Frantext 2000 *dont* relative clauses (subject vs. object subextractions) See page 129 for the confidence intervals (here seven comparisons for subject and five for object). The percentage is given for each group (extraction out of the subject vs. extraction out of the object).

instances of the categories quantifier and relational, and the frequency of the category part-whole is not significantly different from zero.

We fitted a logistic regression model predicting the source of extraction (subject = 1; object = 0) for the kind of relation, and we performed a residual diagnostic to test the predictions of the model. The detailed results of the model are given in Table B.2.<sup>3</sup>

No category of relation is a good predictor for the variable to be explained, but if we drop all possible single terms (the different relations),<sup>4</sup> the effect of the variable relation in predicting the source of the extraction becomes significant ( $p < 0.005$ ). Overall, there is a difference with respect to the kind of relation between *dont* and its head noun in extraction out of the subject compared to extraction out of the object.

<sup>3</sup>Validation of the model: The regression model is valid iff the number of data points is at least equal to 5 times the number of explanatory variables. Here, it must be at least equal to 35, and there are 91 data points. Furthermore, the residual diagnostics are compelling. The model is therefore valid.

<sup>4</sup>In order to do this, I used the function `drop1()` from the R package *stats* (R Core Team 2018).

Table B.2: Results of the logistic regression

	Estimate	SE	<i>z</i>	<i>p</i>	Odd.ratio
(Intercept)	0.560	0.443	1.2627	0.2067	1.75
part-whole	1.232	0.765	1.6105	0.1073	3.43
patient	-1.946	0.906	-2.1470	0.0318	7.00
possession	0.229	0.698	0.3278	0.7431	1.26
quality	-0.714	0.711	-1.0035	0.3156	2.04
quantifier	17.006	2284.102	0.0074	0.9941	24312471.33
relational	17.006	1615.104	0.0105	0.9916	24312471.33

There is thus a difference between FTB and Frantext, which is probably due to both the corpora and to our searches. On the one hand, the corpora diverge in the kind of texts they contain. Newspaper articles have a large number of quantifiers because their texts often aim to provide objective descriptions of a situation (numbers being considered objective facts), and often deal with economics. Frantext, by contrast, contains a lot of autobiographical texts, with an introspective dimension. On the other hand, because we only looked at relatives with an animate antecedent, there are many social or family relations (brother, mother, uncle, etc.) and many body parts (part-whole) in our results for Frantext. In that corpus we observe an asymmetry in the subextractions. Part-whole and relational are rare (or completely absent) in extraction out of objects.

### B.3 *Dont* relatives in Frantext 1900–1913

Figure B.3 gives the proportion of every kind of relation between *dont* and its head noun in extraction out of subjects in Frantext 1900–1913, comparing it to extraction out of direct objects as a baseline. The results corroborate to a certain extent what we see in Frantext 2000–2013. Part-whole is the most common relation in extraction out of the subject (similar in Frantext 2000–2013) and agent/cause and quality are similarly the most common relations in extraction out of the object (in Frantext 2000–2013, agent/cause and patient were the most common relations). In extraction out of the subject, the frequency of the category relational is not significantly above zero. In extraction out of the object, the categories relational, quantifier and possession have frequencies not significantly different from zero.

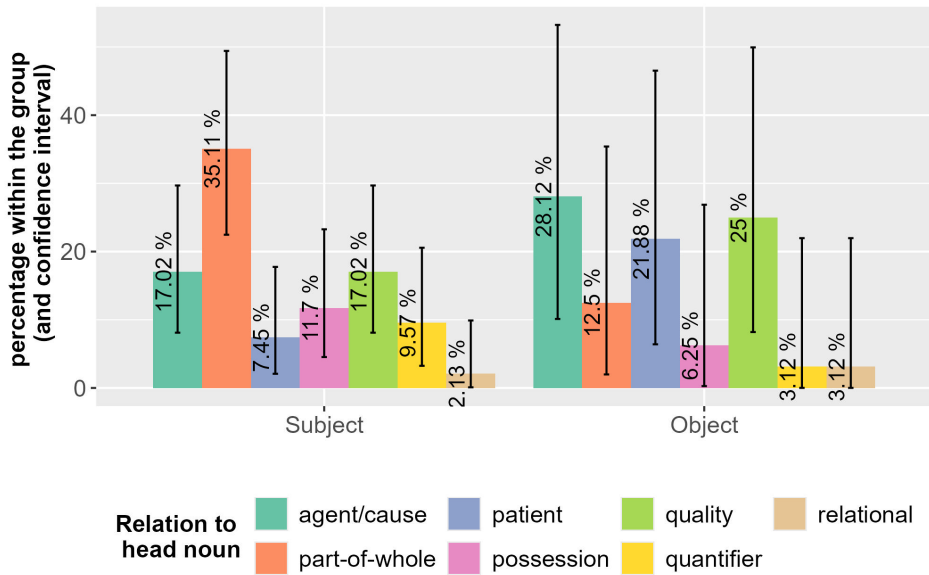

Figure B.3: Semantics relations in Frantext 1900 *dont* relative clauses (subject vs. object subextractions). See page 129 for the confidence intervals (here seven comparisons for subject and five for object). The percentage is given for each group (extraction out of the subject vs. extraction out of the object).

We fitted a logistic regression model predicting the source of extraction (subject = 1; object = 0) for the kind of relation, and we performed a residual diagnostic to test the predictions of the model. The detailed results of the model are given in Table B.3.<sup>5</sup>

In this model, part-whole is close to the threshold for being a good predictor for the variable to be explained (but still  $p > 0.05$ ). If we drop all possible single terms in the model, the effect of the variable relation in explaining the source of the extraction becomes significant ( $p < 0.05$ ). Overall, there is a difference with respect to the kind of relation between *dont* and its head noun in extraction out of the subject compared to extraction out of the object.

*Dont* relative clauses are similar in Frantext in the periods 2000–2013 and 1900–1913. Generally speaking, the relation between the head subject noun and the

<sup>5</sup>Validation of the model: The regression model is valid iff the number of data points is at least equal to 5 times the number of explanatory variables. Here, it must be at least equal to 35, and there are 134 data points. Furthermore, the residual diagnostics are compelling. The model is therefore valid.

## B Semantic relations in relative clauses (corpus studies)

Table B.3: Results of the logistic regression

	Estimate	SE	<i>z</i>	<i>p</i>	Odd.ratio
(Intercept)	0.693	0.408	1.6979	0.0895	2.00
part-whole	1.224	0.629	1.9445	0.0518	3.40
patient	-0.827	0.659	-1.2541	0.2098	2.29
possession	1.012	0.870	1.1622	0.2451	2.75
quality	0.000	0.577	0.0000	1.0000	1.00
quantifier	1.504	1.130	1.3307	0.1833	4.50
relational	0.000	1.291	0.0000	1.0000	1.00

extracted *dont* is often a part-whole relation, whereas the one between the head object noun and *dont* is often a patient-event relation.

### B.4 *De qui* relatives in Frantext 2000–2013

Figure B.4 illustrates the different semantic relations between the filler *de qui* and the head noun. The most frequent relation for both subject and object is agent/cause. We found no instances of the quantifier relation for subjects and the number of instances with quantifier and relational for objects is not significantly above zero.

We fitted a logistic regression model predicting the source of extraction (subject = 1; object = 0) for the kind of relation, and we performed a residual diagnostic to test the predictions of the model. The detailed results of the model are given in Table B.4.<sup>6</sup>

No single category is a significant predictor for the source of the extraction. If we drop all possible single terms in the model, the effect of the variable relation in explaining the source of the extraction becomes significant ( $p < 0.05$ ).

In Frantext 2000–2013, we do not observe any difference between the use of *dont* and the use of *de qui*.<sup>7</sup>

<sup>6</sup>Validation of the model: The regression model is valid iff the number of data points is at least equal to 5 times the number of explanatory variables. Here, it must be at least equal to 35, and there are 83 data points. Furthermore, the residual diagnostics are compelling. The model is therefore valid.

<sup>7</sup>An additional model (crossing the semantic relation with the distinction between subject and object) with data from both *dont* and *de qui* in Frantext 2000–2013 shows that the semantic relation is not a good predictor of the choice for one relative phrase over the other ( $p = 0.37889$ ),

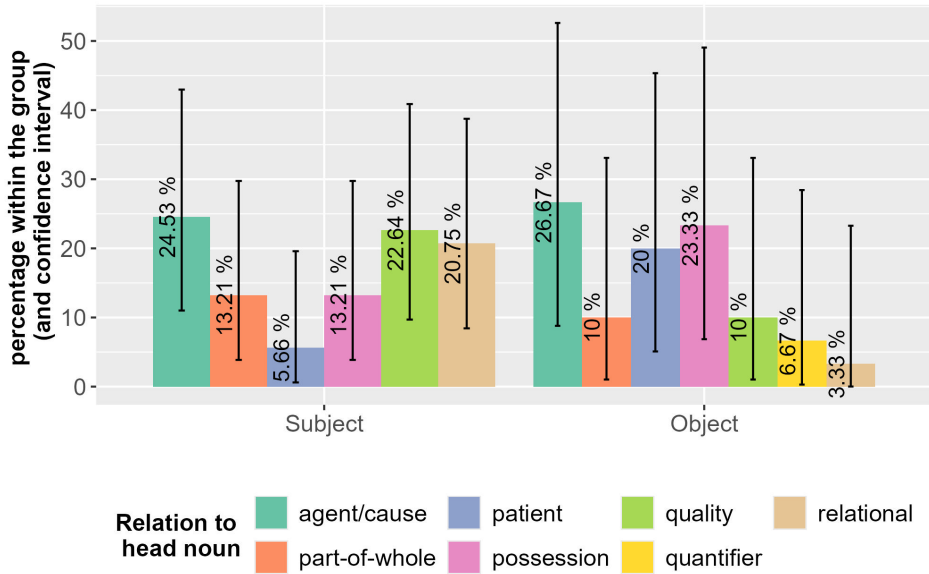

Figure B.4: Semantics relations in Frantext 2000 *de qui* relative clauses (subject vs. object subextractions). See page 129 for the confidence intervals (here seven comparisons). The percentage is given for each group (extraction out of the subject vs. other extraction).

Table B.4: Results of the logistic regression

	Estimate	SE	<i>z</i>	<i>p</i>	Odd.ratio
(Intercept)	0.4855	0.4494	1.0804	0.2799	1.63
part-whole	0.3618	0.8235	0.4393	0.6604	1.44
patient	-1.1787	0.8378	-1.4068	0.1595	3.25
possession	-0.4855	0.6983	-0.6953	0.4869	1.63
quality	0.9008	0.7865	1.1453	0.2521	2.46
quantifier	-17.052	1696.734	-0.0100	0.9920	25434065.63
relational	1.9124	1.1370	1.6819	0.0926	6.77

## B.5 *De qui* relatives in Frantext 1900–1913

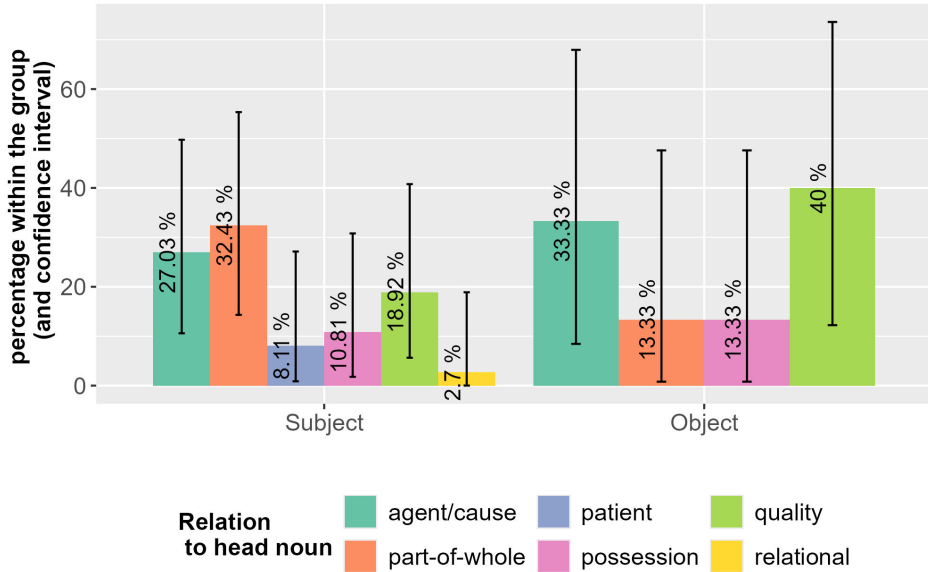

Figure B.5: Semantic relations in Frantext 1900 *de qui* relative clauses (subject vs. object subextractions). See page 129 for the confidence intervals (here six comparisons for subjects and four comparisons for objects). The percentage is given for each group (extraction out of the subject vs. other extraction).

Figure B.5 illustrates the different semantic relations between the filler and the head noun, and their proportions, comparing extraction out of the subject and out of the object. Just as in *dont* relative clauses in Frantext 1900–1913, part-whole is the most common relation in extraction out of the subject and agent/cause and quality are the most common in extraction out of the object. There are no relationals with objects and not significantly more than zero with subjects. Moreover, there are no instances of the patient relation for extraction out of object, which is probably the most striking difference with respect to *dont* relative clauses (compare with Figure B.3).

We fitted a logistic regression model predicting the source of extraction (subject = 1; object = 0) for the kind of relation, and we performed a residual diagnostic

---

though there is a significant interaction of semantic role with subject vs. object ( $p = 0.03278$ ). This interaction is difficult to interpret. The diagnostics for this model are not good, therefore this result should be observed with caution.



to test the predictions of the model. The detailed results of the model are given in Table B.5.<sup>8</sup>

Table B.5: Results of the logistic regression

	Estimate	SE	<i>z</i>	<i>p</i>	Odd.ratio
(Intercept)	0.788	0.539	1.4618	0.1438	2.20
part-whole	1.003	0.935	1.0730	0.2833	2.73
patient	16.778	2284.102	0.0073	0.9941	19338335.90
possession	−0.095	1.020	−0.0934	0.9256	1.10
quality	−0.634	0.775	−0.8186	0.4130	1.89
relational	16.778	3956.180	0.0042	0.9966	19338335.90

No category of relation is a good predictor for the variable to be explained, even if we drop all possible single terms in the model. The semantic relations are therefore not a good predictor for the extraction site.

The main difference between these corpus results and the previous ones from Frantext has to do with the relation patient: it is absent in this corpus, whereas it is the most typical semantic relation in the other three case. We cannot generalize it to all extractions out of the object with *de qui*, given the results for Frantext 2000–2013. We notice a tendency when comparing Frantext 2000 and Frantext 1900, namely that there are few relationals in Frantext 1900 (and many relationals in extraction out of the subject in Frantext 2000), and this without distinction between *dont* and *de qui*.

## B.6 Duquel relatives in Frantext 2000–2013

Figure B.6 illustrates the different semantic relations between the filler and the head noun, and their proportions, comparing extraction out of the subject and out of the object. There are not enough occurrences to run a meaningful regression model (hence the very large confidence intervals in the Figure). Still, the observations we made previously for Frantext hold: there are many part-whole relations in extraction out of the subject and many patient relations in extraction out of the object.

<sup>8</sup>Validation of the model: The regression model is valid iff the number of data points is at least equal to 5 times the number of explanatory variables. Here, it must be at least equal to 35, and there are 53 data points. Furthermore, the residual diagnostics are compelling. The model is therefore valid.

## B Semantic relations in relative clauses (corpus studies)

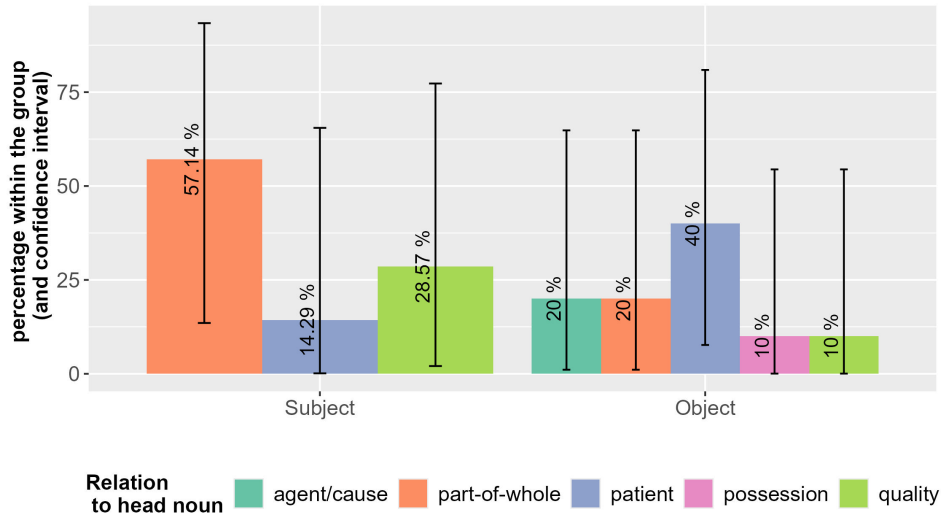

Figure B.6: Semantic relations in Frantext 2000 *duquel* relative clauses (subject vs. object subextractions). See page 129 for the confidence intervals (here three comparisons for subjects and five comparisons for objects). The percentage is given for each group (extraction out of the subject vs. other extraction).

## B.7 Conclusion

As far as semantic relations are concerned, the results for FTB and Frantext are very different. In FTB, there is a predominance of possessive relations, which is not found in Frantext. I would imagine that the genre of the texts that the respective corpora are built on plays a major role in this distinction.

If we look only at the Frantext results, we can see a difference between subject and object. In extraction out of the subject we find many part-whole and relational relations (the latter only in Frantext 2000). In extraction out of the object we mainly find patient, quality and agent relations. In general, however, the filler itself does not seem to be a factor.

I do not know what is responsible for the diachronic difference between Frantext 2000–2013 and Frantext 1900–1913 (the latter having almost no relationals). As for the difference between subjects and objects, I suspect that it can be linked to the type of nouns that are most often used as subject or as object: Are relationals such as *father*, *sister* more often used as subjects/agent while events such as *management*, *death* and qualities such as *beauty*, *colour* are more often used as objects? The scope of these corpus studies does not allow me to answer this question.

## Appendix C: Number, definiteness and restrictiveness in relative clauses (corpus studies)

In the corpus studies described in this book, I have annotated several properties of the relative clauses that are not reported in Part II of the book, since these factors do not provide any conclusive explanation. The results are, however, worth mentioning, if only because they show that the factors in question do not play a dominant role.

I annotated two factors regarding the antecedent of the relative clauses: whether the antecedent was singular or plural, and definite or indefinite. Figure C.1 illustrates the results for the number of the antecedent, while Figure C.2 on page 505 shows the results for definiteness of the antecedent. Antecedents are often singular and often definite. Extraction type seems to be irrelevant, so extraction out of the subject does not stand out.

Finally, I annotated the restrictiveness of the relative clauses, following the guidelines explained above (Appendix A). The results of this annotation are displayed in Figure C.3.

In general, we can say that the corpus contains about as many restrictive as non-restrictive relative clauses. Extraction of the complement of the verb stands out in that there seem to be a particularly high number of restrictive occurrences (also in extractions of the complement of the adjective, but the observation is based on few occurrences, thus it is not very reliable).

Following Song (2017), the extracted element in a non-restrictive relative clause is necessarily a topic, but not in a restrictive relative clause. For this reason, we expected to find more non-restrictive relative clauses in extraction out of the subject than in the other kinds of extraction. The data show that relativization out of the subject is quite often non-restrictive, but not necessarily more than relativization out of other kinds of NPs. Relativization out of the subject with *duquel* appears to be an outlier with very few restrictive relative clauses.

Table C.1 compares extraction out of subjects with extraction out of objects and extraction of the complement of the verb, because these types of extraction

C Number, definiteness and restrictiveness in relative clauses (corpus studies)

always have a frequency significantly above zero. The + sign indicates that there are more non-restrictive relative clauses in extraction out of a subject, and the – sign indicates that there are fewer. A doubled sign signals that the difference is large.

We can see a clear tendency that confirms our expectations. However, the difference with extraction out of the object is not as strong as expected. Notice, however, that our annotation criteria for restrictiveness were somewhat rudimentary, and that it would be desirable to take into account the whole context in determining the value of the restrictiveness. The internal information structure of restrictive and non-restrictive relative clauses is not well understood in general and should be studied on its own.

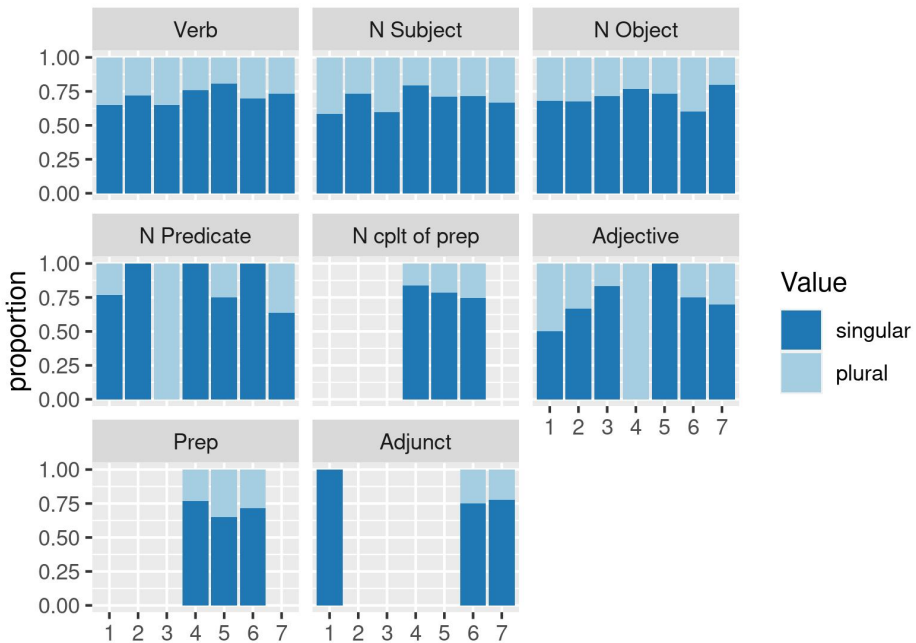

1 = FTB dont ; 2 = Frantext 2000 dont ; 3 = Frantext 1900 dont ;  
 4 = Frantext 2000 de qui ; 5 = Frantext 1900 ;  
 6 = Frantext duquel ; 7 = Frantext avec qu-

Figure C.1: Number of the antecedent for all relative clauses in the corpus studies

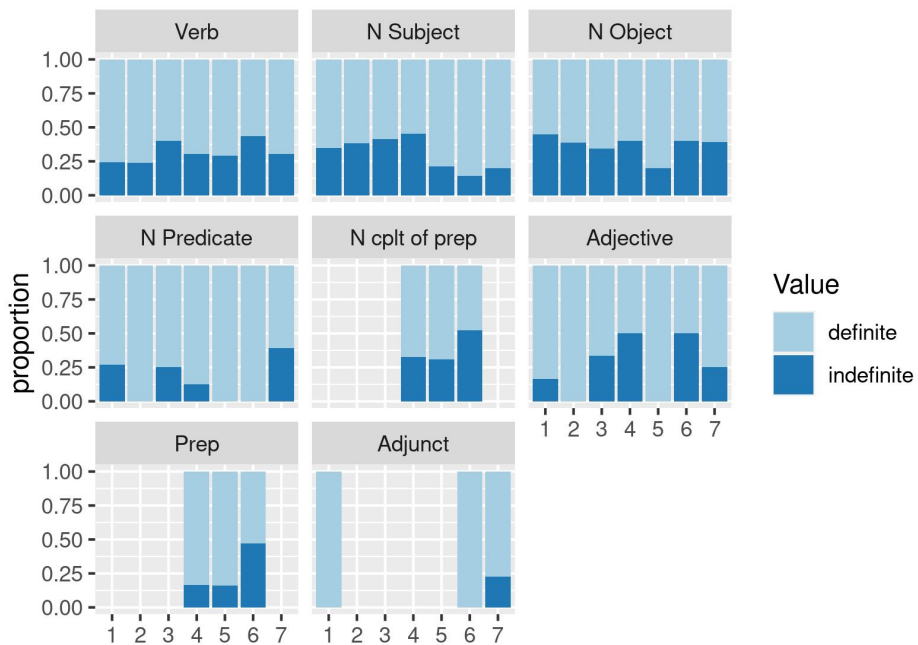

1 = FTB dont ; 2 = Frantext 2000 dont ; 3 = Frantext 1900 dont ;  
 4 = Frantext 2000 de qui ; 5 = Frantext 1900 ;  
 6 = Frantext duquel ; 7 = Frantext avec qu-

Figure C.2: Definiteness of the antecedent for all relative clauses in the corpus studies

C Number, definiteness and restrictiveness in relative clauses (corpus studies)

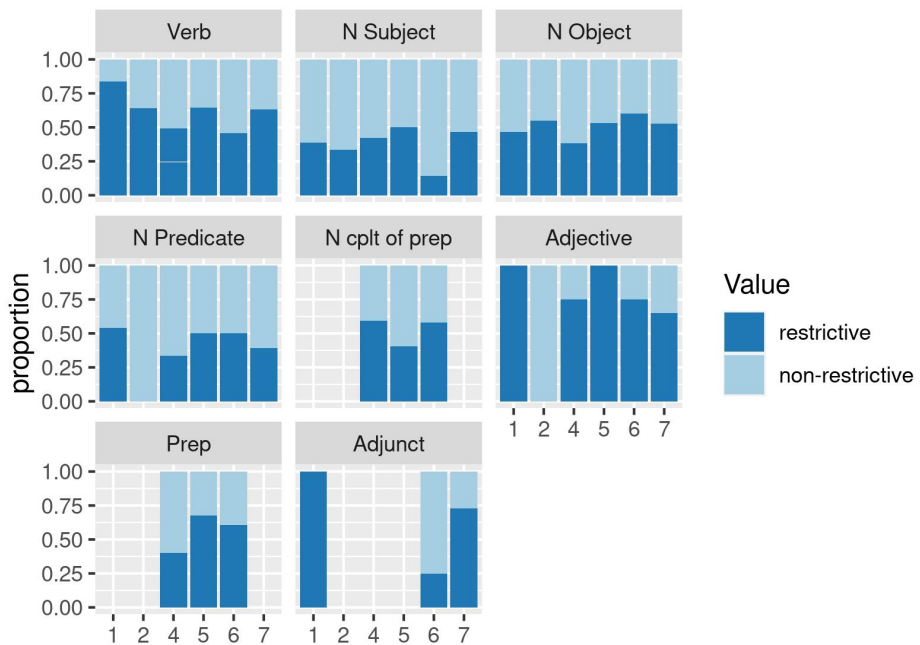

1 = FTB dont ; 2 = Frantext 2000 dont ; 3 = Frantext 1900 dont ;  
 4 = Frantext 2000 de qui ; 5 = Frantext 1900 ;  
 6 = Frantext duquel ; 7 = Frantext avec qu-

Figure C.3: Restrictiveness of all relative clauses from the corpus studies

Table C.1: Comparison of the amount of non-restrictive relative clauses in the different corpus studies

	More non-restrictive relative clauses in extractions out of the subject than in extractions...	
	...of the comple- ment of the verb	...out of the object
<i>dont</i> in FTB	++	+
<i>dont</i> in Frantext 2000–2013	++	++
<i>dont</i> in Frantext 1900–1913	+	+
<i>de qui</i> in Frantext 2000–2013	+	--
<i>de qui</i> in Frantext 1900–1913	++	+
<i>duquel</i> in Frantext 2000–2013	+	++
<i>avec + wh</i> in Frantext 2000–2013	++	+





## Appendix D: Exclusion criteria for participants' data

The decision on whether or not to include a participant's response in the statistical analysis was made by applying the same criteria for all experiments.

1. The responses of the participants that did not complete the entire experiment were deleted altogether, as were the data from participants who did not give their explicit consent.
2. For legal reasons, I only kept the data from participants over 18 (age of legal majority in France).
3. I only kept data from native monolingual speakers of French. Participants were asked to name their native language, but also to mention the other languages they speak and their level of proficiency on a scale of 1 to 10. I considered as non-native speakers participants who indicated a language other than French as their native language, did not answer the question, or gave an unrelated answer. I considered as bilingual or potentially bilingual participants who either indicated two languages as their native languages or indicated an L2 with a proficiency of 10. The data from non-native speakers, bilinguals and potential bilinguals are excluded from the statistical analysis.
4. I only kept only data from participants who grew up in a French-speaking country. I considered as francophone country any country in which French is one of the official languages, as well as Algeria and Morocco. The data from participants who did not grow up in a francophone country according to this criterion are excluded from the statistical analysis. Overall, most likely due to the way the participants were recruited for internet experiments (over social media per snowballing effects), or to the fact that the experiments run in the lab were conducted at the Université Paris Cité, the great majority of participants grew up in Metropolitan France.

#### *D Exclusion criteria for participants' data*

5. Based on the answers to comprehension questions (if there were any), I computed each participant's accuracy. For this, the answers to the comprehension questions related to practice items and ungrammatical controls were not taken into account. If I noticed that a condition or a particular set of distractors received an unusually high number of incorrect answers overall, then these answers were also excluded from computing the participants' accuracy rate. I mention these details in the relevant sections. Data from participants with an accuracy rate below 75% were excluded from the statistical analysis.
6. Finally, I sometimes had to exclude participants that did not discriminate between conditions in my test items, and always gave the same rating (or almost always with one or two outliers). I mention these cases in the relevant sections.

# Appendix E: Experiment 3, detailed results and analysis

I report here the detailed steps of the statistical analysis for the eye tracking study described in Section 8.4 (Experiment 3). Note that I only report results from statistical models that satisfied the validity criteria and whose residual analysis was compelling (see on page 175).

Reaction times typically have a non-normal distribution with a very long tail for longer reaction times. For this reason, following the usual methodology in reading time studies, the results presented here are based on log-transformed reading times, whose distribution is closer to normal.

I suppressed data for skipped regions, i.e. regions for which there was no fixation at all.

## E.1 Total reading times

In order to look at total reading times, I built a subset of the data in which I suppressed outliers, i.e. total reading time measurements that were more than 3 standard deviations away from each participant's mean reading time (each region in each condition considered separately).

Figure E.1 shows the total reading times for the experimental items and Figure E.2 shows in more detail the distribution of the reading times for regions 3+4+5<sup>1</sup>. A visual inspection of the graph does not reveal strong increase of reading times for the subextraction from subject or the subextraction from object. Only the medium condition with a clitic subject is read faster, which is not surprising.

We fitted a first linear mixed model to predict log-transformed total reading times on the three regions by comparing extraction out of the subject and out of the object with nominal subject (mean centered with subject coded positive and object coded negative) crossed with extraction type (mean centered with no extraction coded negative and subextraction coded positive). We included the

---

<sup>1</sup>Note that skipped regions are then necessarily counted as having a reading time of 0.

E Experiment 3, detailed results and analysis

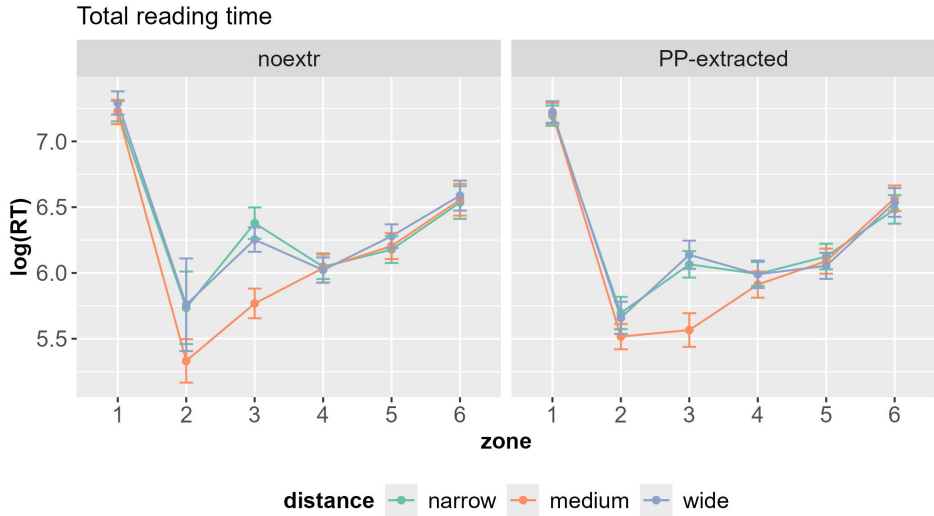

Figure E.1: Region means and 95% confidence intervals for the log-transformed total reading times of all conditions in Experiment 3

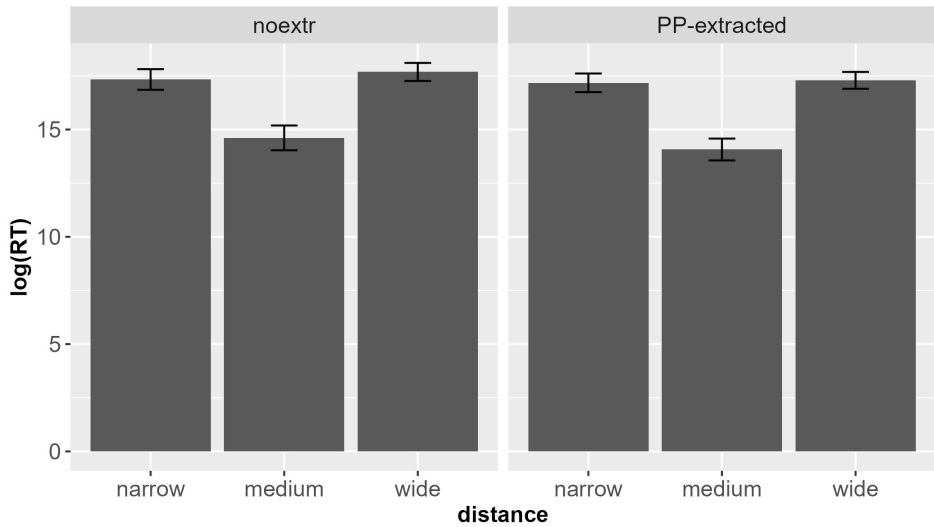

Figure E.2: Sum of the mean log-transformed total reading times for the regions 3, 4 and 5 for each condition of Experiment 3 with 95% confidence intervals.

length of the region (number of characters) as covariate<sup>2</sup>, and random slopes for all fixed effects grouped by participants and items. The results of the model are reported in Table E.1. There is a significant effect of extraction type such that coordination controls were read more slowly than the extraction conditions, but there is no significant interaction.

Thus the data do not confirm any of the predictions. Extraction out of the subject does not lead to increased total reading times, and nor does extraction out of the object. Surprisingly, total reading times are even shorter in extraction than in non-extraction.

Table E.1: Results of the Linear Mixed Model (model n°1)

	Estimate	SE	df	<i>t</i>	Pr(>   <i>t</i>  )	OR
(Intercept)	0.856	0.577	152.52	1	0.1403	2.35
extraction type	-0.131	0.061	23.29	-2	<0.05	1.14
distance	0.169	0.105	25.66	2	0.1213	1.18
length	0.557	0.014	521.85	39	<0.001	1.74
extraction type:distance	-0.042	0.073	29.31	-1	0.5741	1.04

## E.2 Regressions in region 3 (subject)

I built a different subset of the data in which I suppressed outliers, i.e. regression path duration measurements that were more than 3 standard deviations away from each participant's mean reading time (each region in each condition considered separately). Figure E.3 shows the regression path durations for the experimental items.

Figure E.4 displays in more detail the distribution of the regression path durations for regions 3.

We fitted a second linear mixed model to predict log-transformed regression path duration by comparing extraction out of the subject and out of the object with nominal subject (mean centered with subject coded positive and object coded negative) crossed with extraction type (mean centered with no extraction coded negative and subextraction coded positive). We included the length of the region (number of characters) and the frequency of the lemma as covariates, and

<sup>2</sup>Frequency is not an appropriate covariate, because we are looking at several regions at the same time.

E Experiment 3, detailed results and analysis

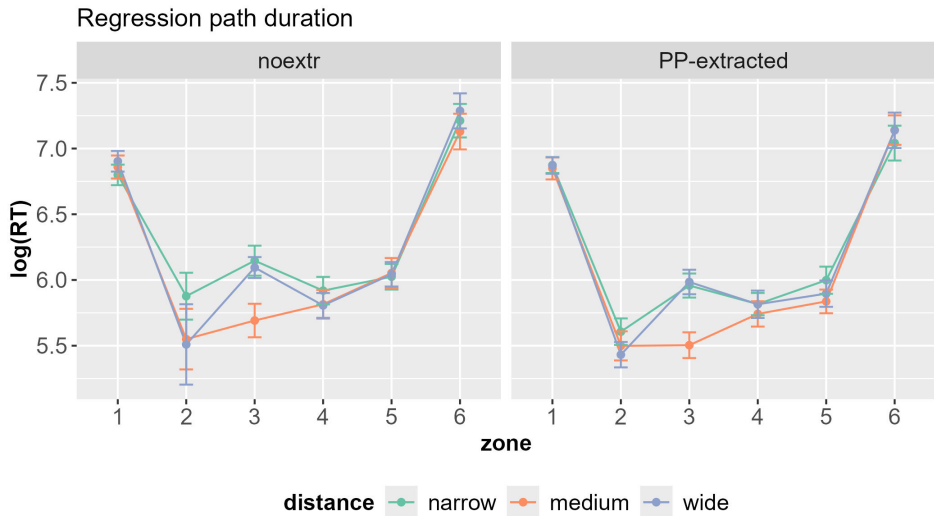

Figure E.3: Region means and 95% confidence intervals for the log-transformed regression path durations of all conditions in Experiment 3

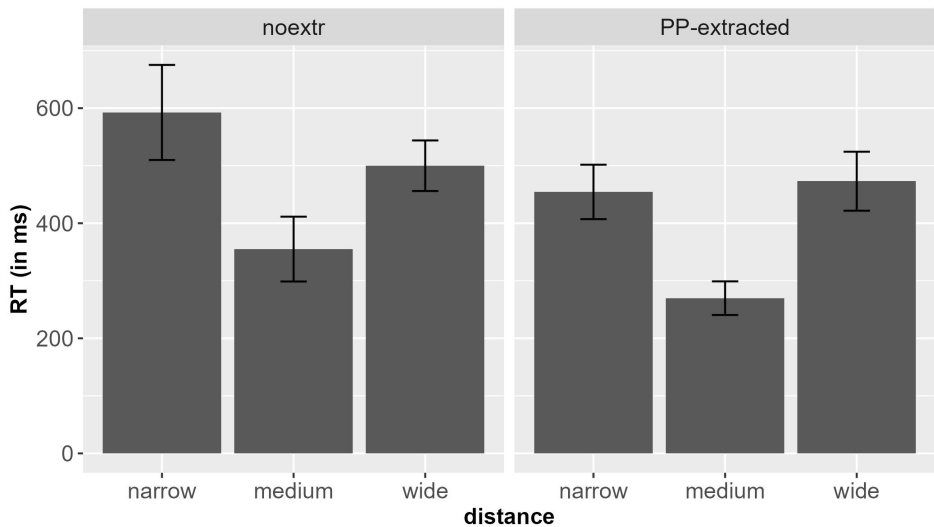

Figure E.4: Regression path durations for region 3 for each condition of Experiment 3 with 95% confidence intervals.

*E.2 Regressions in region 3 (subject)*

random slopes for all fixed effects grouped by participants and items. The results of the model are reported in Table E.2. There is a significant effect of extraction type: coordination controls were read more slowly than the extraction conditions, but there is no significant interaction.

Table E.2: Results of the Linear Mixed Model (model n°2)

	Estimate	SE	df	<i>t</i>	Pr(>   <i>t</i>  )	OR
(Intercept)	5.578	0.149	158.43	37	<0.001	264.55
extraction type	-0.074	0.026	30.28	-3	<0.01	1.08
distance	0.002	0.025	29.04	0	0.9238	1.00
length	0.040	0.012	137.54	3	<0.005	1.04
frequency	0.000	0.000	92.50	0	0.8217	1.00
extraction type:distance	-0.020	0.026	27.04	-1	0.4538	1.02

Figure E.5 shows the rate and number of regressions out from the subject.

We fitted a third binominal regression model to predict regressions out (yes coded 1, no coded 0). The explanatory variables were distance (mean centered with narrow distance coded positive and wide distance coded negative) crossed with extraction type (mean centered with no extraction coded negative, subextraction coded positive). We included the length of the region (number of characters) and the frequency of the lemme as covariates, and participants and items as random factors. The results of the model are reported in Table E.3. Only length is a significant predictor.

Table E.3: Results of the Regression Mixed Model (model n°3)

	Estimate	SE	<i>z</i>	Pr(>   <i>z</i>  )	OR
(Intercept)	-3.3413	0.7353	-4.5439	<0.001	28.26
extraction type	0.0394	0.104	0.3785	0.7051	1.04
distance	0.0013	0.1068	0.0118	0.9906	1.00
length	0.1714	0.0583	2.9403	<0.005	1.19
frequency	0.0018	0.0014	1.3136	0.189	1.00
extraction type:distance	0.1435	0.1039	1.3809	0.1673	1.15

E Experiment 3, detailed results and analysis

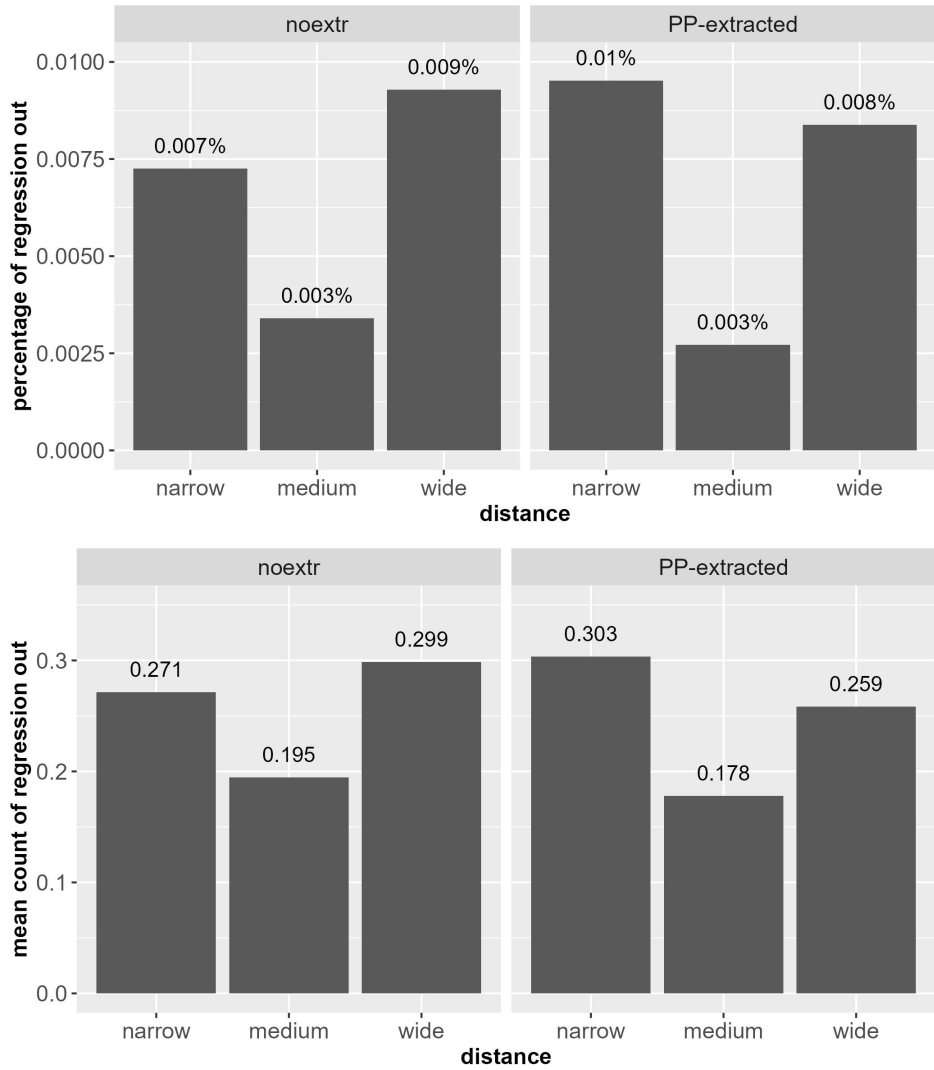

Figure E.5: Rate (top) and mean number (bottom) of regressions out in Region 3 in Experiment 3



We fitted a fourth poisson regression model to predict the number of regressions out. The explanatory variables were distance (mean centered with narrow distance coded positive and wide distance coded negative) crossed with extraction type (mean centered with no extraction coded negative and subextraction coded positive). We included the length of the region (number of characters) as a covariate<sup>3</sup>, and participants and items as random factors. The results of the model are reported in Table E.4 and are similar to model n°3.

Table E.4: Results of the Regression Mixed Model (model n°4)

	Estimate	SE	z	Pr(>  z )	OR
(Intercept)	-2.832	0.5322	-5.3215	<0.001	16.98
extraction type	-0.0004	0.0774	-0.005	0.996	1.00
distance	0.0154	0.0769	0.2005	0.8411	1.02
length	0.114	0.0427	2.6712	<0.01	1.12
extraction type:distance	0.064	0.0771	0.8305	0.4062	1.07

Figure E.6 shows the rate and number of regressions in to the subject. We observe that there are fewer regressions in with extraction out of the subject than in both the coordination controls and in extraction out of the object.

We fitted a fifth binominal regression model to predict regressions in (yes coded 1, no coded 0). The explanatory variables were distance (mean centered with narrow distance coded positive and wide distance coded negative) crossed with extraction type (mean centered with no extraction coded negative and subextraction coded positive). We included the length of the region (number of characters) as a covariate, and participants and items as random factors. The results of the model are reported in Table E.5. There is a significant main effect of extraction type, such that regressions in back to the subject are more frequent in the non-extraction conditions. There is also a significant interaction, such that the subject non-extraction condition has more regressions in.

We fitted a sixth poisson regression model to predict the number of regressions in. The explanatory variables were distance (mean centered with narrow distance coded positive and wide distance coded negative) crossed with extraction type (mean centered with no extraction coded negative and subextraction coded positive). We included the length of the region (number of characters) as a covariate, and participants and items as random factors. The results of the model are reported in Table E.6 and corroborate the results of model n°5.

<sup>3</sup>In this and some following models, I did not add the frequency of the lemma as a covariate, because it makes the model fail to converge.

E Experiment 3, detailed results and analysis

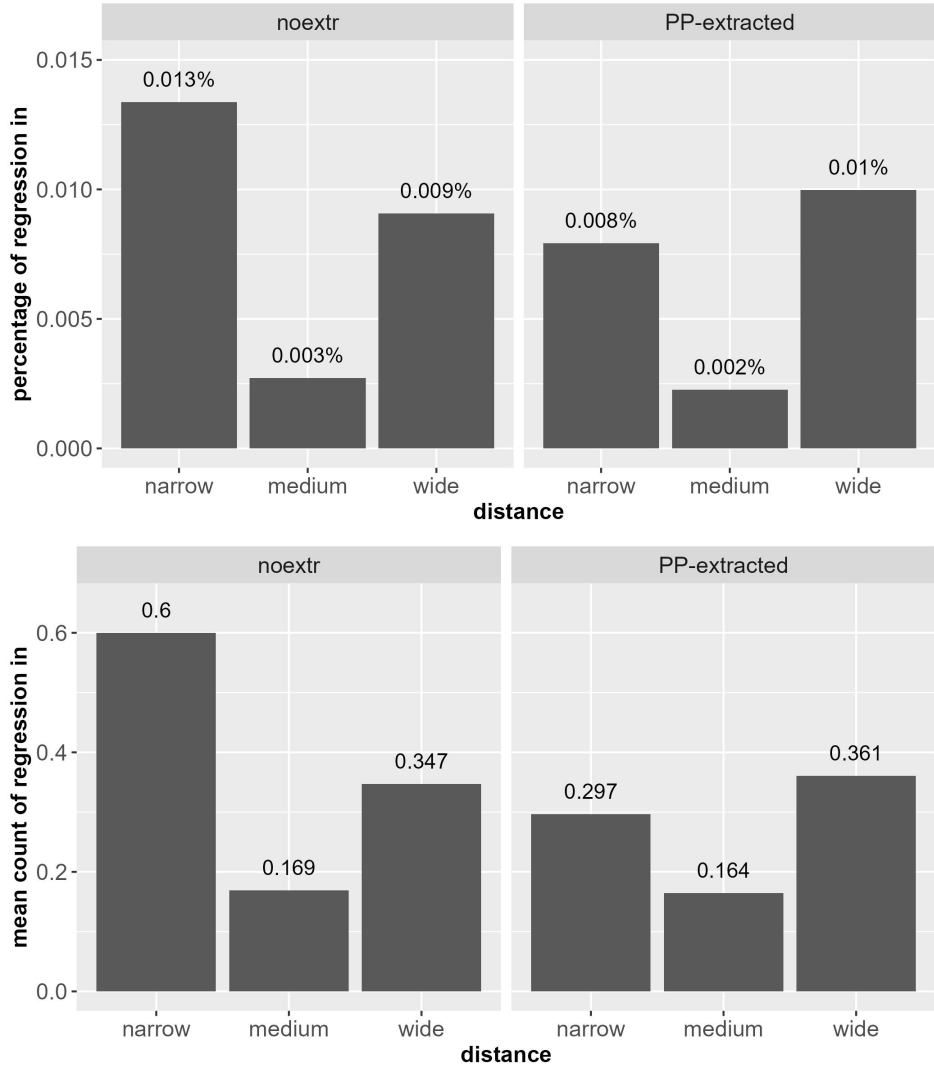

Figure E.6: Rate (top) and mean number (bottom) of regressions in in Region 3 in Experiment 3

### E.3 First fixations and regression path durations in region 4 (verb)

Table E.5: Results of the Regression Mixed Model (model n°5)

	Estimate	SE	$z$	Pr(>   $z$  )	OR
(Intercept)	-1.2344	0.7187	-1.7176	0.0859	3.44
extraction type	-0.229	0.102	-2.2444	<0.05	1.26
distance	0.1072	0.1019	1.0519	0.2928	1.11
length	0.0193	0.0592	0.3258	0.7446	1.02
extraction type:distance	-0.3126	0.1024	-3.0536	<0.005	1.37

Table E.6: Results of the Regression Mixed Model (model n°6)

	Estimate	SE	$z$	Pr(>   $z$  )	OR
(Intercept)	-1.5653	0.4991	-3.1362	<0.005	4.78
extraction type	-0.1756	0.0673	-2.6073	<0.01	1.19
distance	0.0849	0.067	1.2673	0.2051	1.09
length	0.0273	0.0408	0.6683	0.504	1.03
extraction type:distance	-0.197	0.0678	-2.907	<0.005	1.22

There is therefore no evidence in the data that extraction out of the subject leads to longer regression path duration, or to more regressions. Actually, there are more regressions in back to the subject when extraction is out of the object than when it is out of the subject.

### E.3 First fixations and regression path durations in region 4 (verb)

Figure E.7 shows the distribution of the first fixations and regression path durations for region 4. For first fixation durations, I built a different subset of the data in which I suppressed outliers, i.e. first fixation duration measurements that were more than 3 standard deviations away from each participant's mean reading time (each region in each condition considered separately).

We fitted a seventh linear mixed model to predict log-transformed first fixation durations by comparing extraction out of the subject and out of the object with nominal subject (mean centered with subject coded positive and object coded negative) crossed with extraction type (mean centered with no extraction coded

E Experiment 3, detailed results and analysis

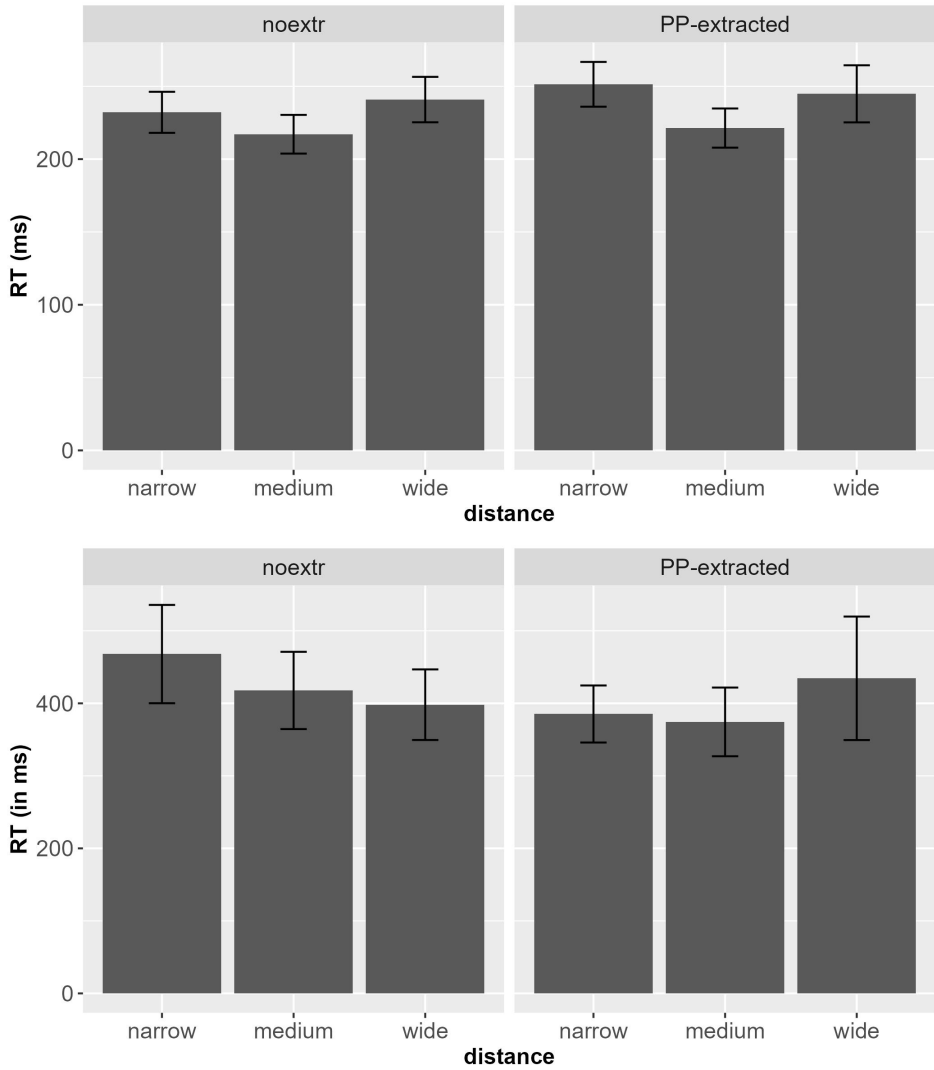

Figure E.7: First fixation durations (top) and regression path durations (bottom) in region 4 for each condition of Experiment 3 with 95% confidence intervals.

negative and subextraction coded positive). We included the length of the region (number of characters) and the frequency of the lemma as covariates, and participants and items as random variables. The results of the model are reported in Table E.7. There is a significant main effect of extraction type: the coordination controls were read more slowly than the extraction conditions, but there is no significant interaction.

Table E.7: Results of the Linear Mixed Model (model n°7)

	Estimate	SE	df	<i>t</i>	Pr(>   <i>t</i>  )	OR
(Intercept)	5.468	0.086	403.36	64	<0.001	236.91
extraction type	0.012	0.017	515.96	1	0.4713	1.01
distance	-0.014	0.018	514.96	-1	0.4151	1.01
length	-0.006	0.009	520.02	-1	0.5205	1.01
frequency	0.000	0.000	522.58	-1	0.1397	1.00
extr. type:distance	0.018	0.017	515.64	1	0.2937	1.02

We fitted an eighth linear mixed model to predict log-transformed regression path durations by comparing extraction out of the subject and out of the object with nominal subject (mean centered with subject coded positive and object coded negative) crossed with extraction type (mean centered with no extraction coded negative and subextraction coded positive). We included the length of the region (number of characters) and the frequency of the lemma as covariates, and participants and items as random variables. The results of the model are reported in Table E.8. There is no significant factor in the model, even though there is a small hint of an interaction effect (marginally significant), which we can also identify in Figure E.7: this effect rather disfavors extraction out of the object, where the verb is read slightly more slowly, especially compared to the non-extraction control.

There is therefore no evidence in the data for region 4 that extraction out of the subject leads to longer reading times. If anything, there is a reverse tendency, possibly indicating a small spillover effect on the verb for extractions out of the object.

## E.4 Regressions in region 5 (object)

Figure E.8 shows in more detail the distribution of the regression path durations for region 5, and Figure E.9 shows the rate and number of regressions out from

E Experiment 3, detailed results and analysis

Table E.8: Results of the Linear Mixed Model (model n°8)

	Estimate	SE	df	<i>t</i>	Pr(>   <i>t</i>  )	OR
(Intercept)	5.748	0.125	82.27	46	<0.001	313.66
extraction type	-0.031	0.022	493.48	-1	0.1545	1.03
distance	0.024	0.023	513.06	1	0.3118	1.02
length	0.014	0.013	60.08	1	0.2921	1.01
frequency	-0.001	0.000	155.47	-2	0.1356	1.00
extr. type:distance	-0.042	0.022	494.78	-2	0.0585	1.04

the object.

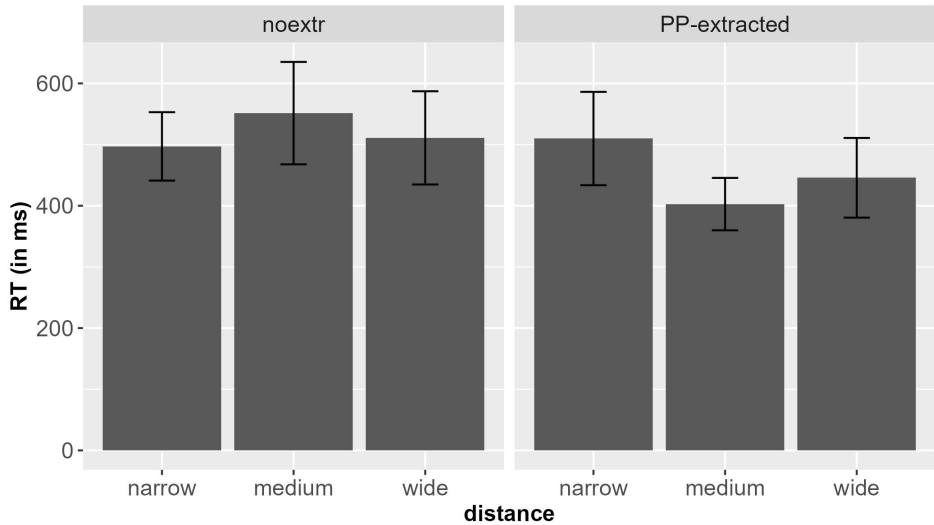

Figure E.8: Regression path durations for region 5 for each condition of Experiment 3 with 95% confidence intervals.

I will first compare the narrow vs. wide distance conditions, then the medium vs. wide distance conditions.

We fitted a ninth linear mixed model to predict log-transformed regression path durations by comparing extraction out of the subject and out of the object with nominal subject (mean centered with subject coded positive and object coded negative) crossed with extraction type (mean centered with no extraction coded negative and subextraction coded positive). We included the length of the

E.4 Regressions in region 5 (object)

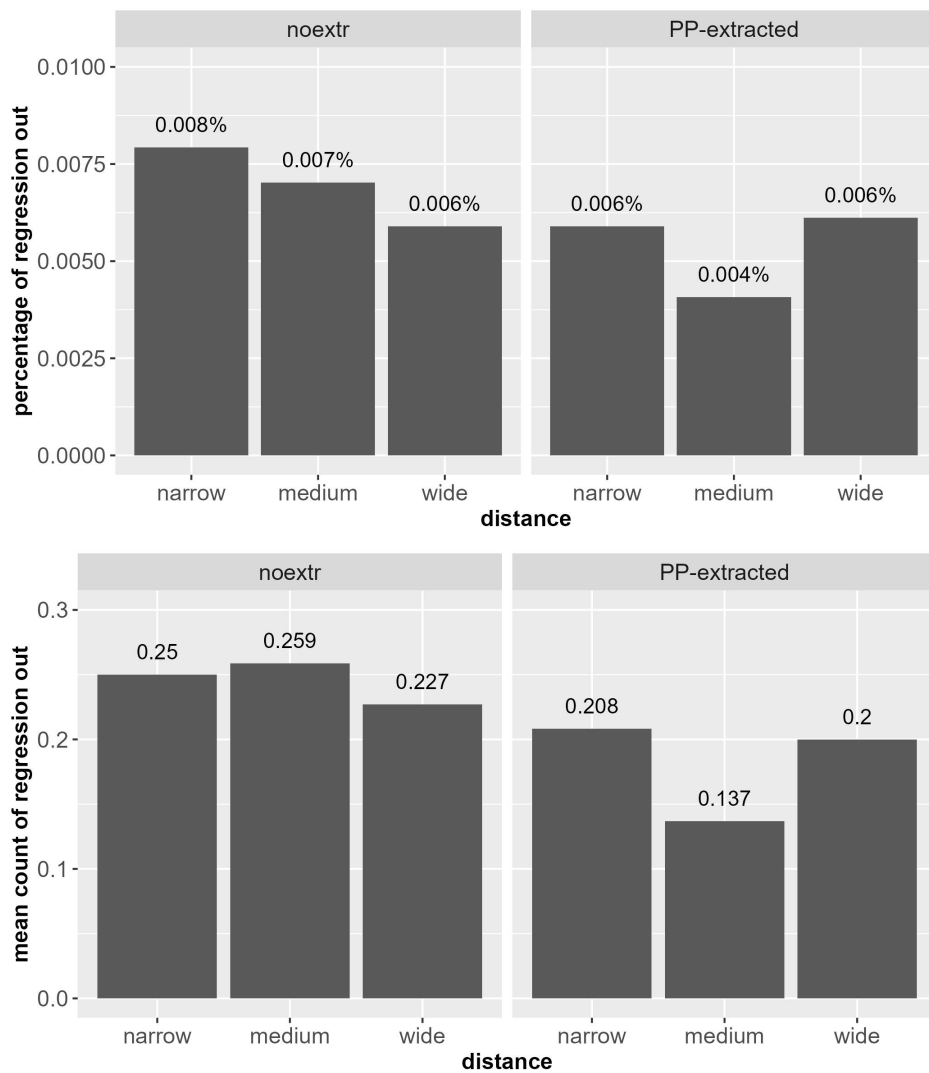

Figure E.9: Rate (top) and mean number (bottom) of regressions out in Region 5 in Experiment 3

*E Experiment 3, detailed results and analysis*

region (number of characters) and the frequency of the lemma as covariates, and participants and items as random variables. The results of the model are reported in Table E.9. There is no significant effect in the model.

Table E.9: Results of the Linear Mixed Model (model n°9)

	Estimate	SE	df	<i>t</i>	Pr(>   <i>t</i>  )	OR
(Intercept)	5.590	0.197	38.29	28	<0.001	267.78
extraction type	-0.037	0.022	509.65	-2	0.1038	1.04
distance	0.034	0.023	534.32	1	0.1482	1.03
length	0.033	0.016	33.51	2	0.0536	1.03
frequency	0.001	0.000	175.50	1	0.2014	1.00
extr. type:distance	0.017	0.022	510.91	1	0.4454	1.02

We fitted a tenth binominal regression model to predict regressions out (yes coded 1, no coded 0). The explanatory variables were distance (mean centered with narrow distance coded positive and wide distance coded negative) crossed with extraction type (mean centered with no extraction coded negative and subextraction coded positive). We included the length of the region (number of characters) as a covariate, and participants and items as random factors. The results of the model are reported in Table E.10. Once again, there is no significant effect.

Table E.10: Results of the Regression Mixed Model (model n°10)

	Estimate	SE	<i>z</i>	Pr(>   <i>z</i>  )	OR
(Intercept)	-2.1957	1.0002	-2.1951	<0.05	8.99
extraction type	-0.082	0.111	-0.7388	0.46	1.09
distance	0.0799	0.1112	0.7186	0.4724	1.08
length	0.0481	0.0848	0.5675	0.5704	1.05
extraction type:distance	-0.1322	0.1111	-1.1891	0.2344	1.14

We fitted an eleventh poisson regression model to predict the number of regressions out. The explanatory variables were distance (mean centered with narrow distance coded positive and wide distance coded negative) crossed with extraction type (mean centered with no extraction coded negative and subextraction coded positive). We included the length of the region (number of characters) as a



covariate, and participants and items as random factors. The results of the model are reported in Table E.11 and there is again no significant effect.

Table E.11: Results of the Regression Mixed Model (model n°11)

	Estimate	SE	$z$	$\text{Pr}( >  z  )$	OR
(Intercept)	-2.6385	0.7112	-3.71	<0.001	13.99
extraction type	-0.0626	0.0901	-0.6942	0.4875	1.06
distance	0.0366	0.0903	0.4052	0.6853	1.04
length	0.0799	0.0596	1.3393	0.1805	1.08
extraction type:distance	-0.0271	0.0904	-0.2995	0.7646	1.03

There is therefore no evidence in the data that extraction out of the subject leads to longer regression path durations, or to more regressions, and also no evidence to the contrary. I now compare the medium and wide conditions, where the DLT expects a processing difference.

We fitted a twelfth linear mixed model to predict log-transformed regression path durations by comparing extraction out of the object with clitic subject and with nominal subject (mean centered with clitic subject coded positive and nominal subject coded negative) crossed with extraction type (mean centered with no extraction coded negative and subextraction coded positive). We included the length of the region (number of characters) and the frequency of the lemma as covariates, and participants and items as random variables. The results of the model are reported in Table E.12. There is a main effect of extraction type, such that the extraction conditions have shorter regression path durations than the control conditions. There is no interaction effect.

Table E.12: Results of the Linear Mixed Model (model n°12)

	Estimate	SE	df	$t$	$\text{Pr}( >  t  )$	OR
(Intercept)	5.431	0.190	41.56	29	<0.001	228.28
extraction type	-0.061	0.023	520.45	-3	<0.01	1.06
distance	-0.040	0.024	541.89	-2	0.0934	1.04
length	0.047	0.016	34.74	3	<0.01	1.05
frequency	0.000	0.000	142.43	0	0.8521	1.00
extr. type:distance	-0.042	0.023	522.26	-2	0.0677	1.04

## E Experiment 3, detailed results and analysis

We fitted a thirteenth binominal regression model to predict regressions out (yes coded 1, no coded 0). The explanatory variables were distance (mean centered with medium distance coded positive and wide distance coded negative) crossed with extraction type (mean centered with no extraction coded negative and subextraction coded positive). We included the length of the region (number of characters) as a covariate, and participants and items as random factors. The results of the model are reported in Table E.13. In line with model n°12, there is a main effect of extraction type, such that there are more regressions out in the control conditions than the subextraction conditions.

Table E.13: Results of the Regression Mixed Model (model n°13)

	Estimate	SE	$z$	Pr(>   $z$  )	OR
(Intercept)	-2.8826	0.8373	-3.4426	<0.001	17.86
extraction type	-0.2885	0.1139	-2.5326	<0.05	1.33
distance	-0.1803	0.1143	-1.5775	0.1147	1.20
length	0.1031	0.0698	1.4773	0.1396	1.11
extraction type:distance	-0.0822	0.1139	-0.7221	0.4702	1.09

A fourteenth poisson regression model trying to predict the number of regressions out failed to converge.

There is therefore no evidence in the data that extraction out of the object with a nominal subject leads to longer regression path durations, or to more regressions, than extraction out of the object with a clitic subject.

### E.5 Regressions at the extraction site (subject/object)

Figure E.10 shows the regression path durations at the extraction site, i.e. in region 3 for the subject conditions and in region 5 for the object conditions (here we only consider the cases with a nominal subject).

We fitted a fifteenth linear mixed model to predict log-transformed regression path durations by comparing extraction out of the subject and extraction out of the object with nominal subject (mean centered with subject coded positive and object coded negative) crossed with extraction type (mean centered with no extraction coded negative and subextraction coded positive). We included the length of the region (number of characters) and the frequency of the lemma as covariates, and participants and items as random variables. The results of the

E.5 Regressions at the extraction site (subject/object)

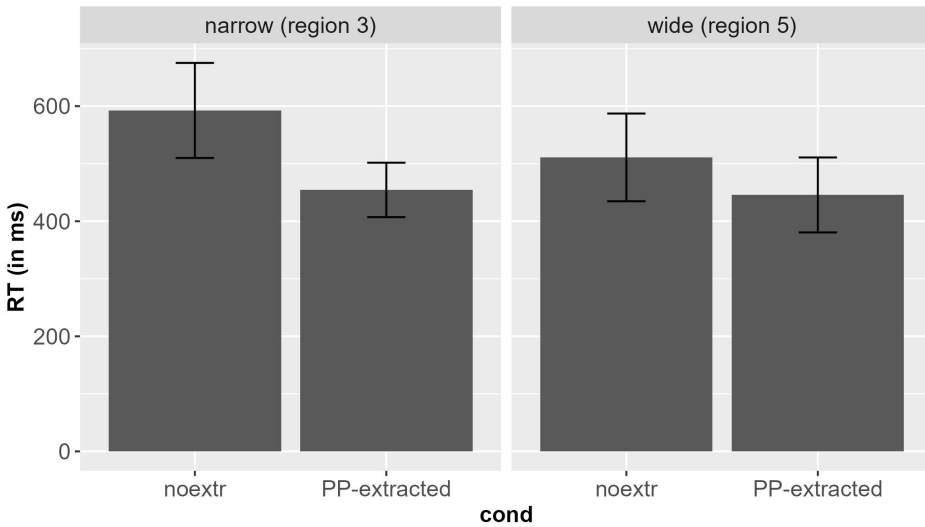

Figure E.10: Regression path durations for region 3 on the one hand (subject) and region 5 on the other hand (object) of Experiment 3 with 95% confidence intervals.

model are reported in Table E.14. There is a main effect of extraction type, such that the extraction conditions have shorter regression path durations than the control conditions. There is also a main effect of distance, such that the subject conditions have longer regression path durations. However, there is no significant interaction effect.

Table E.14: Results of the Linear Mixed Model (model n°15)

	Estimate	SE	df	<i>t</i>	Pr(>   <i>t</i>  )	OR
(Intercept)	5.424	0.170	31.62	32	<0.001	226.87
extraction type	-0.076	0.023	516.04	-3	<0.005	1.08
distance	0.054	0.024	531.36	2	<0.05	1.05
length	0.048	0.014	26.63	3	<0.005	1.05
frequency	0.001	0.000	119.86	2	<0.05	1.00
extr. type:distance	-0.024	0.023	508.31	-1	0.3036	1.02

Hence, when we compare extraction sites, there is no evidence that extraction out of the subject leads to longer regression path durations.

## E.6 Regressions in region 2 (relative word)

I will first look at the rate of regressions in, comparing the three distance conditions in pairs, and then turn to the amount of regressions in.

Figure E.11 shows the rate of regressions in to the relative word or coordination word. There are hardly any regressions in in the coordinations, therefore the following three models only compare the extraction conditions. We observe an increase of regressions in as the distance increases.

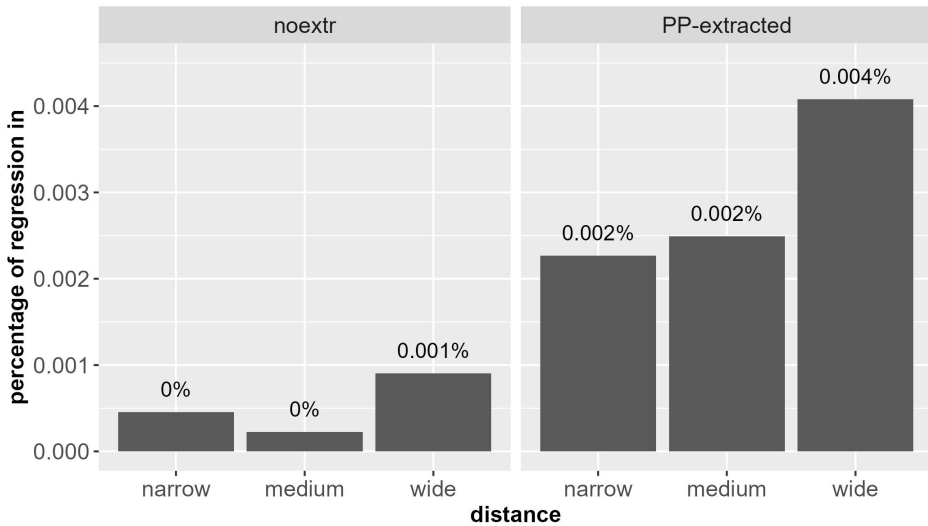

Figure E.11: Rate of regressions in in Region 2 of Experiment 3

I first compared the narrow vs. medium distance. We fitted a sixteenth binomial regression model to predict regressions in (yes coded 1, no coded 0). The explanatory variable was the distance (mean centered with narrow distance coded positive and medium distance coded negative). We included the frequency of the lemma as a covariate<sup>4</sup>, and participants and items as random factors. The results of the model are reported in Table E.15. There is no significant effect in the model.

I then compared the narrow vs. wide distance. We fitted a seventeenth binomial regression model to predict regressions in (yes coded 1, no coded 0). The explanatory variable was the distance (mean centered with narrow distance coded positive and wide distance coded negative). We included the frequency of the lemma as a covariate, and participants and items as random factors. The results of the model are reported in Table E.16. There is no significant effect in the model.

<sup>4</sup>In models 16–19, I did not add the length of the region as a covariate, because it makes the model fail to converge.

E.6 Regressions in region 2 (relative word)

Table E.15: Results of the Regression Mixed Model (model n°16)

	Estimate	SE	$z$	Pr(>   $z$  )	OR
(Intercept)	-1.6939	0.2925	-5.7917	<0.001	5.44
distance	0.0789	0.2478	0.3184	0.7502	1.08
frequency	-0.001	0.0033	-0.2966	0.7668	1.00

Table E.16: Results of the Regression Mixed Model (model n°17)

	Estimate	SE	$z$	Pr(>   $z$  )	OR
(Intercept)	-2.7473	1.0553	-2.6034	<0.01	15.60
distance	0.3616	0.7011	0.5157	0.6061	1.44
frequency	0.0087	0.0072	1.2047	0.2283	1.01

Finally, I compared the medium vs. wide distance. We fitted an eighteenth binominal regression model to predict regressions in (yes coded 1, no coded 0). The explanatory variable was the distance (mean centered with the medium distance coded positive and the wide distance coded negative). We included the frequency of the lemma as a covariate, and participants and items as random factors. The results of the model are reported in Table E.17. There is no significant effect in the model, but a slight tendency such that extraction out of the object with clitic subject shows fewer regressions in back to the relative word.

Table E.17: Results of the Regression Mixed Model (model n°18)

	Estimate	SE	$z$	Pr(>   $z$  )	OR
(Intercept)	-1.8922	0.45	-4.2053	<0.001	6.63
distance	-0.4382	0.2403	-1.8234	0.0682	1.55
frequency	0.0012	0.0028	0.4218	0.6732	1.00

Figure E.12 shows the amount of regression in to the relative word or coordination word. What is striking here is the higher number of regressions in for coordinations, given that there were only very few occurrences (Figure E.11). This is especially true for the wide distance condition.

I first compared the narrow vs. medium distance. We fitted a nineteenth poisson regression model to predict the number of regressions in. The explanatory

E Experiment 3, detailed results and analysis

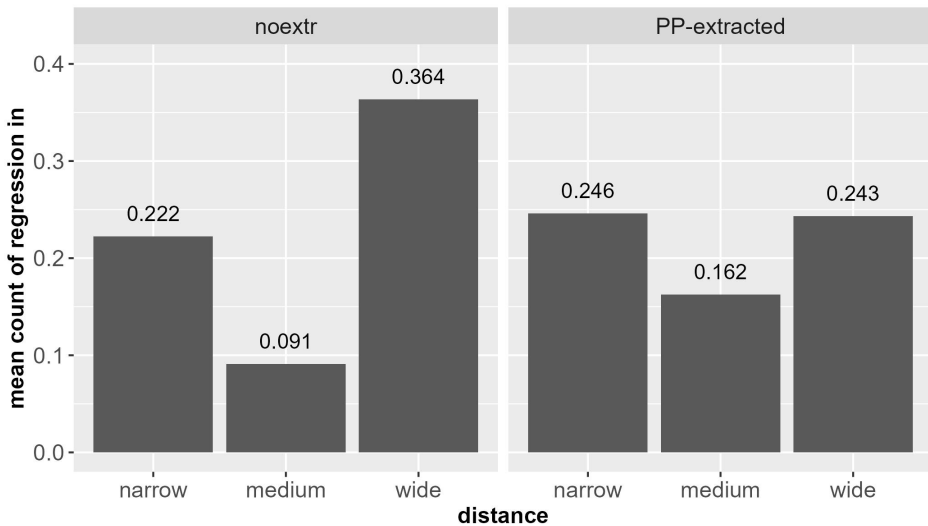

Figure E.12: Mean number of regressions in in Region 2 of Experiment 3

variables were distance (mean centered with narrow distance coded positive, medium coded negative) crossed with extraction type (mean centered with no extraction coded negative and subextraction coded positive). We included the frequency of the lemma as a covariate, and participants and items as random factors. The results of the model are reported in Table E.18. There is no significant effect in the model.

Table E.18: Results of the Regression Mixed Model (model n°19)

	Estimate	SE	z	Pr(>  z )	OR
(Intercept)	-1.7567	0.2936	-5.9841	<0.001	5.79
extraction type	0.1731	0.2365	0.7321	0.4641	1.19
distance	0.1922	0.2005	0.9587	0.3377	1.21
frequency	-0.0012	0.0029	-0.4327	0.6652	1.00
extraction type:distance	-0.074	0.215	-0.3441	0.7308	1.08

I then compared the narrow vs. wide distance. We fitted a twentieth poisson regression model to predict the number of regressions in. The explanatory variables were distance (mean centered with narrow distance coded positive and

E.6 Regressions in region 2 (relative word)

wide distance coded negative) crossed with extraction type (mean centered with no extraction coded negative and subextraction coded positive). We included the frequency of the lemma and the length of the region (number of characters) as covariates, and random slopes for all fixed effects grouped by participants and items. The results of the model are reported in Table E.19. There is no significant effect in the model.

Table E.19: Results of the Regression Mixed Model (model n°20)

	Estimate	SE	<i>z</i>	Pr(>   <i>z</i>  )	OR
(Intercept)	-3.521	2.880	-1.2224	0.2216	33.81
extraction type	-0.240	0.661	-0.3629	0.7167	1.27
distance	-0.149	0.371	-0.4005	0.6888	1.16
frequency	0.003	0.003	1.1416	0.2536	1.00
length	0.393	0.758	0.5181	0.6044	1.48
extraction type:distance	0.233	0.508	0.4586	0.6466	1.26

Finally I compared the medium vs. wide distance. We fitted a twenty-first poisson regression model to predict the number of regressions in. The explanatory variables were distance (mean centered with the medium distance coded positive and the wide distance coded negative) crossed with extraction type (mean centered with no extraction coded negative and subextraction coded positive). We included the length of the region (number of characters) as a covariate, and participants and items as random factors. The results of the model are reported in Table E.20. There is no significant effect in this model, either.

Table E.20: Results of the Regression Mixed Model (model n°21)

	Estimate	SE	<i>z</i>	Pr(>   <i>z</i>  )	OR
(Intercept)	-3.938	2.399	-1.6416	0.1007	51.29
extraction type	-0.321	0.424	-0.7560	0.4496	1.38
distance	-0.273	0.180	-1.5187	0.1288	1.31
length	0.573	0.633	0.9059	0.3650	1.77
extraction type:distance	0.157	0.208	0.7540	0.4508	1.17

Therefore, apart from a very small tendency with a marginally significant effect of distance in model n°18, there is no evidence that distance has an impact on regressions back to the relative word.





# References

- Abeillé, Anne. 2007. *Les grammaires d'unification*. Paris: Hermes Science publications.
- Abeillé, Anne, Olivier Bonami, Danièle Godard & Jesse Tseng. 2004. The syntax of French N' phrases. In Stefan Müller (ed.), *Proceedings of the 11th International Conference on Head-Driven Phrase Structure Grammar, Center for Computational Linguistics, Katholieke Universiteit Leuven*, 6–26. Stanford: CSLI Publications. DOI: 10.21248/hpsg.2004.1.
- Abeillé, Anne, Olivier Bonami, Danièle Godard & Jesse Tseng. 2006. The syntax of French *à* and *de*: An HPSG analysis. In Patrick Saint-Dizier (ed.), *Syntax and semantics of prepositions* (Text, Speech and Language Technology 29), 147–162. Dordrecht: Springer. DOI: DOI:10.1007/1-4020-3873-9\_10.
- Abeillé, Anne & Robert D. Borsley. 2008. Comparative correlatives and parameters. *Lingua* 118(8). 1139–1157. DOI: 10.1016/j.lingua.2008.02.001.
- Abeillé, Anne, Robert D. Borsley & Maria-Teresa Espinal. 2006. The syntax of comparative correlatives in French and Spanish. In Stefan Müller (ed.), *Proceedings of the 13th International Conference on Head-Driven Phrase Structure Grammar, Varna*, 6–26. Stanford: CSLI Publications. DOI: 10.21248/hpsg.2006.1.
- Abeillé, Anne & Rui P. Chaves. 2020. Coordination. In Stefan Müller, Anne Abeillé, Robert D. Borsley & Jean-Pierre Koenig (eds.), *Head-Driven Phrase Structure Grammar: The handbook* (Empirically Oriented Theoretical Morphology and Syntax), 725–776. Berlin: Language Science Press. DOI: 10.5281/zenodo.5599848.
- Abeillé, Anne, Lionel Clément & Loïc Liégeois. 2019. Un corpus arboré pour le français : le French Treebank. *TAL Traitement Automatique des Langues* 60(2). 19–43.
- Abeillé, Anne, Lionel Clément & François Toussanel. 2003. Building a treebank for French. In Anne Abeillé (ed.), *Treebanks*. Dordrecht: Kluwer.
- Abeillé, Anne, Benoît Crabbé, Jean-Marie Marandin & Danièle Godard. 2012. French questioning declaratives: A corpus study. In *Proceedings of the 16th Workshop on the Semantics and Pragmatics of Dialogue – Full Papers*, 70–79. Paris: SEMDIAL. <http://semdial.org/anthology/papers/Z/Z12/Z12-3011/>.

## References

- Abeillé, Anne & Danièle Godard. 1997. The syntax of French negative adverbs. In Danielle Forget, Paul Hirschbuhler, France Martineau & Maria Luisa Rivero (eds.), *Negation and polarity*, 11–13. Amsterdam & Philadelphia: John Benjamins. DOI: 10.1075/cilt.155.02abe.
- Abeillé, Anne & Danièle Godard. 1999a. French word order and lexical weight. In Robert D. Borsley (ed.), *Nature and function of syntactic categories*, 325–360. Bradford: Emerald Group.
- Abeillé, Anne & Danièle Godard. 1999b. La position de l'adjectif épithète en français : le poids des mots. *Recherches Linguistiques de Vincennes* 28. 9–32.
- Abeillé, Anne & Danièle Godard. 2002. The syntactic structures of French auxiliaries. *Language* 78. 404–452.
- Abeillé, Anne & Danièle Godard. 2003. The syntactic flexibility of adverbs: French degree adverbs. In Stefan Müller (ed.), *Proceedings of the 10th International Conference on Head-Driven Phrase Structure Grammar, Michigan State University*, 26–46. Stanford: CSLI Publications. DOI: 10.21248/hpsg.2003.2.
- Abeillé, Anne & Danièle Godard. 2007. Les relatives sans pronom relatif. In Michaël Abecassis, Laure Ayosso & Elodie Vialleton (eds.), *Le français parlé au 21ème siècle: Normes et variations dans les discours et en interaction*, vol. 2, 37–60. Paris: L'Harmattan. <https://halshs.archives-ouvertes.fr/halshs-00748342>.
- Abeillé, Anne, Danièle Godard & Frédéric Sabio. 2008. Two types of NP preposing in French. In Stefan Müller (ed.), *Proceedings of the 15th International Conference on Head-Driven Phrase Structure Grammar, National Institute of Information and Communications Technology, Keihanna*, 306–324. Stanford, CA: CSLI Publications. DOI: 10.21248/hpsg.2008.18.
- Abeillé, Anne, Danièle Godard & Ivan A. Sag. 1998. *French relative clauses*. manuscript.
- Abeillé, Anne, Barbara Hemforth & Elodie Winckel. 2016. Les relatives en *dont* du français : études empiriques. In Franck Neveu, Gabriel Bergounioux, Marie-Hélène Côté, Jean-Michel Fournier & Linda Hriba et Sophie Prévost (eds.), *5e Congrès Mondial de Linguistique Française* (SHS Web of Conferences 27). DOI: 10.1051/shsconf/20162714011.
- Abeillé, Anne, Barbara Hemforth, Elodie Winckel & Edward Gibson. 2020. Extraction from subjects: Differences in acceptability depend on the discourse function of the construction. *Cognition* 204. Article 104293. DOI: 10.1016/j.cognition.2020.104293.
- Abeillé, Anne & Elodie Winckel. 2019. Extracting out of the subject in French: Experimental evidence. In *Proceedings of the first workshop on Quantitative Syntax (Quasy, SyntaxFest 2019, Paris)*, 68–74. Stroudsburg, PA: Association for Computational Linguistics. DOI: 10.18653/v1/W19-7908.

- Abeillé, Anne & Elodie Winckel. 2020. French subject island? Empirical studies of *dont* and *de qui*. *Journal of French Language Studies* 30. 275–300. DOI: 10.1017/S0959269520000137.
- Adli, Aria. 2006. French wh-in-situ questions and syntactic optionality: Evidence from three data types. *Zeitschrift für Sprachwissenschaft* 25(2). 163–203. DOI: 10.1515/ZFS.2006.007.
- Aguila-Multner, Gabriel & Berthold Crysmann. 2020. French clitic climbing as periphrasis. *Linguisticæ Investigationes* 43(1). 23–61.
- Alexiadou, Artemis, Elena Anagnostopoulou & Florian Schäfer. 2015. *External arguments in transitivity alternations: A layering approach*. Oxford: Oxford University Press. DOI: 10.1093/acprof:oso/9780199571949.001.0001.
- Almeida, Diego. 2014. Subliminal wh-islands in Brazilian Portuguese and the consequences for syntactic theory. *Revista da ABRALIN* 13(2). DOI: 10.5380/rabl.v13i2.39611.
- Ambar, Manuela. 2002. Wh-questions and Wh-exclamatives: Unifying mirror effects. In Claire Beyssade, Reineke Bok-Bennema, Frank Drijkoningen & Paola Monachesi (eds.), *Romance languages and linguistic theory 2000: Selected papers from Going Romance 2000, Utrecht, 30 November–2 December* (Current Issues in Linguistic Theory 232), 15–40. Amsterdam: John Benjamins Publishing Company. DOI: 10.1075/cilt.232.03amb.
- Ambridge, Ben & Adele E. Goldberg. 2008. The island status of clausal complements: Evidence in favor of an information structure explanation. *Cognitive Linguistics* 19(3). 349–381.
- An, Aixiu. 2020. *Theoretical, empirical and computational approaches to agreement with coordination structures*. Paris: Université Paris Cité. (Ph.D. Thesis).
- Aoun, Joseph & Yen-hui Audrey Li. 1993. Wh-elements in situ: Syntax or LF? *Linguistic Inquiry* 24(2). 199–238. <https://www.jstor.org/stable/4178811>.
- Ariel, Mira. 1988. Referring and accessibility. *Journal of Linguistics* 24. 65–87.
- Armstrong, Nigel. 2001. *Social and stylistic variation in spoken French: A comparative approach* (Studies in Language, Culture and Society 8). Amsterdam & Philadelphia: John Benjamins.
- ATILF, CNRS & Université de Lorraine. 2016. *Base textuelle FRANTEXT*. Version décembre 2016. <http://www.frantext.fr>.
- Austen, Jane. 1981. *The complete novels*. New York: Gramercy.
- Bach, Emmon & George Horn. 1976. Remarks on “Conditions on Transformations”. *Linguistic Inquiry* 7(2). 265–299. <https://www.jstor.org/stable/4177922>.
- Bader, Markus & Jana Häussler. 2010. Toward a model of grammaticality judgments. *Journal of Linguistics* 46(2). 273–330. DOI: 10.1017/S0022226709990260.

## References

- Baroni, Marco, Silvia Bernardini, Adriano Ferraresi & Eros Zanchetta. 2009. The WaCky wide web: A collection of very large linguistically processed web-crawled corpora. *Language Resources and Evaluation* 43(3). 209–226. DOI: DOI: 10.1007/s10579-009-9081-4.
- Barr, Dale J., Roger Levy, Christoph Scheepers & Harry J. Tily. 2013. Random effects structure for confirmatory hypothesis testing: Keep it maximal. *Journal of Memory and Language* 68(3). 255–278.
- Belletti, Adriana & Luigi Rizzi. 1988. Psych-verbs and  $\theta$ -theory. *Natural Language & Linguistic Theory* 6(3). 291–352. <http://www.jstor.com/stable/4047649>.
- Berard, Lolita. 2012. *Dépendances à distance en français contemporain : étude sur corpus "c'est ce qu'on pense qui devrait être fait"*. Université de Lorraine. (Ph.D. Thesis). <http://www.theses.fr/2012LORR0321/document>.
- Beysade, Claire. 2006. La structure de l'information dans les questions : quelques remarques sur la diversité des formes interrogatives en français. *Linx* 55. 173–193. DOI: 10.4000/linx.470.
- Bianchi, Valentina & Cristiano Chesi. 2014. Subject islands, reconstruction, and the flow of the computation. *Linguistic Inquiry* 45(4). 525–569.
- Bianchi, Valentina & Cristiano Chesi. 2015. On a PP/DP asymmetry in extraction. In Elisa Di Domenico, Cornelia Hamann & Simona Matteini (eds.), *Structures, strategies and beyond: Studies in honour of Adriana Belletti* (Linguistik Aktuell/Linguistics Today 223), 47–66. Amsterdam & Philadelphia: John Benjamins. DOI: 10.1075/la.223.03bia.
- Bilbiie, Gabriela & Frédéric Laurens. 2010. Towards a non-elliptical analysis of verbless relative adjuncts. *Bucharest Working Papers in Linguistics* 1. 51–67.
- Bildhauer, Felix. 2008. *Representing information structure in an HPSG grammar of Spanish*. Universität Bremen. (Ph.D. Thesis).
- Bildhauer, Felix & Philippa Cook. 2010. German multiple fronting and expected topic-hood. In Stefan Müller (ed.), *Proceedings of the 17th International Conference on Head-Driven Phrase Structure Grammar, Université Paris Diderot, Paris 7, France*, 68–79. Stanford: CSLI Publications. DOI: 10.21248/hpsg.2010.4.
- Blanche-Benveniste, Claire. 1990. Usages normatifs et non normatifs dans des relatives en français, espagnol, portugais. In Johannes Bechert, Giuliano Bernini & Claude Buridant (eds.), *Towards a typology of European languages*, 317–333. Berlin: Mouton de Gruyter.
- Blaszczak, Joanna, Stefanie Dipper, Gisbert Fanselow, Shinishiro Ishihara, Svetlana Petrova, Stavros Skopeteas, Thomas Weskott & Malte Zimmermann. 2007. Morphology. In Stefanie Dipper, Stavros Skopeteas & Michael Goetze (eds.), *Information structure in cross-linguistic corpora* (Interdisciplinary Studies on

- Information Structure 7), 55–94. Potsdam: Universitätsverlag Potsdam. <https://nbn-resolving.org/urn:nbn:de:kobv:517-opus-14199>.
- Bloom, Paul. 1990. Subjectless sentences in child language. *Linguistic Inquiry* 21(4). 491–504. <http://www.jstor.org/stable/4178692>.
- Bloom, Paul. 1993. Grammatical continuity in language development: The case of subjectless sentences. *Linguistic Inquiry* 24(4). 721–734. <http://www.jstor.org/stable/4178837>.
- Boeckx, Cedric. 1999. Decomposing French questions. *University of Pennsylvania Working Papers in Linguistics* 6(1). 69–80.
- Boeckx, Cedric. 2003. *Islands and chains: Resumption as stranding* (Linguistik Aktuell/Linguistics Today 63). Amsterdam & Philadelphia: John Benjamins.
- Boland, Julie E., Michael K. Tanenhaus, Susan M. Garnsey & Greg N. Carlson. 1995. Verb argument structure in parsing and interpretation: Evidence from wh-questions. *Journal of Memory and Language* 43. 413–432.
- Bolinger, Dwight. 1978. Asking more than one thing at a time. In Henry Hiz (ed.), *Questions* (Synthese Language Library 1), 107–150. Dordrecht: D. Reidel. DOI: 10.1007/978-94-009-9509-3.
- Bonami, Olivier & Elisabeth Delais-Roussarie. 2006. Metrical phonology in HPSG. In Stefan Müller (ed.), *Proceedings of the 13th International Conference on Head-Driven Phrase Structure Grammar, Varna*, 39–59. Stanford: CSLI Publications. DOI: 10.21248/hpsg.2006.3.
- Bonami, Olivier & Danièle Godard. 2001. Inversion du sujet: constituance et ordre des mots. In Jean-Marie Marandin (ed.), *Cahier Jean-Claude Milner*, 117–174. Lagrasse (Aude): Verdier.
- Bonami, Olivier, Danièle Godard & Jean-Marie Marandin. 1998. French subject inversion in extraction contexts. In Gosse Bouma, Geert-Jan Kruijff & Richard T. Oehrle (eds.), *Proceedings Joint Conference on Formal Grammar, Head-Driven Phrase Structure Grammar, and Categorical Grammar*, 101–112.
- Borsley, Robert D. & Berthold Crysmann. 2021. Chapter 13: Unbounded dependencies. In Stefan Müller, Anne Abeillé, Robert D. Borsley & Jean-Pierre Koenig (eds.), *Head-Driven Phrase Structure Grammar: The handbook* (Empirically Oriented Theoretical Morphology and Syntax), 537–594. Berlin: Language Science Press. DOI: 10.5281/zenodo.5599842.
- Bosch, Sina, Iliana De Cesare, Claudia Felser & Ulrike Demske. 2020. *A multi-methodological approach to word order variation in German infinitival complementation*. Talk at Linguistic Evidence 2020. Tübingen. <https://uni-tuebingen.de/en/research/core-research/collaborative-research-centers/crc-833/linguistic-evidence-2020/le-2020-programme> (23 July, 2020).

## References

- Bošković, Željko. 1998. LF movement and the Minimalist Program. In *Proceedings of the North East Linguistic Society*, vol. 28, 43–57. Amherst, MA: GLSA (Graduate Linguistic Student Association).
- Bouma, Gosse, Robert Malouf & Ivan A. Sag. 2001. Satisfying constraints on extraction and adjunction. *Natural Language & Linguistic Theory* 19(1). 1–65. DOI: 10.1023/A:1006473306778.
- Bresnan, Joan & Sam A. Mchombo. 1987. Topic, pronoun, and agreement in Chicheŵa. *Language* 63(4). 741–782. DOI: 10.2307/415717.
- Brew, Chris. 1995. Stochastic HPSG. In Steven P. Abney & Erhard W. Hinrichs (eds.), *Proceedings of the 7th Conference of the EACL*. Dublin: Association for Computational Linguistics. <https://aclanthology.org/E95-1012>.
- Bröker, Norbert. 1999. *Eine Dependenzgrammatik zur Kopplung heterogener Wissensquellen* (Linguistische Arbeiten 405). Tübingen: Max Niemeyer Verlag.
- Burzio, Luigi. 1986. *Italian syntax: A government-binding approach* (Studies in Natural Language and Linguistic Theory 1). Dordrecht: D. Reidel.
- Candito, Marie & Djamé Seddah. 2012a. Effectively long-distance dependencies in French: Annotation and parsing evaluation. In *TLT 11: The 11th international workshop on Treebanks and Linguistic Theories*. Lisbon. <https://hal.archives-ouvertes.fr/hal-00769625>.
- Candito, Marie & Djamé Seddah. 2012b. Le corpus sequoia : Annotation syntaxique et exploitation pour l’adaptation d’analyseur par pont lexical. In *Proceedings of TALN 2012 (in French)*. Grenoble.
- Carroll, John M. 1979. Complex compounds: Phrasal embedding in lexical structures. *Linguistics* 17. 863–877.
- Cattell, Ray. 1976. Constraints on movement rules. *Language* 52(1). 18–50.
- Chafe, Wallace L. 1976. Givenness, contrastiveness, definiteness, subjects, topics and point of view. In Charles N. Li (ed.), *Subject and topic*, 27–55. New York: Academic Press.
- Chaves, Rui P. 2012. On the grammar of extraction and coordination. *Natural Language & Linguistic Theory* 2(30). 465–512.
- Chaves, Rui P. 2013. An expectation-based account of subject islands and parasitism. *Journal of Linguistics* 49(2). 297–344.
- Chaves, Rui P. & Jeruen E. Dery. 2014. Which subject islands will the acceptability of improve with repeated exposure? In Robert E. Sanatana-LaBarge (ed.), *31st West Coast Conference on Formal Linguistics*, 96–106. Somerville: Cascadilla Proceedings Project.
- Chaves, Rui P. & Jeruen E. Dery. 2019. Frequency effects in subject islands. *Journal of Linguistics* 55(3). 475–521. DOI: 10.1017/S0022226718000294.



- Chaves, Rui P. & Michael T. Putnam. 2020. *Unbounded dependency constructions: Theoretical and experimental perspectives*. Oxford: Oxford University Press.
- Cheng, Lisa Lai Shen. 1991. *On the typology of wh-questions*. Massachusetts Institute of Technology. (Ph.D. Thesis). <https://dspace.mit.edu/handle/1721.1/13938> (22 July, 2020).
- Cheng, Lisa Lai Shen & Johan Rooryck. 2000. Licensing Wh-in-situ. *Syntax* 3(1). 1–19. DOI: 10.1111/1467-9612.00022.
- Chomsky, Noam. 1964. Current issues in linguistic theory. In Jerry A. Fodor & Jerrold J. Katz (eds.), *The structure of language: Readings in the philosophy of language*, 50–118. Englewood Cliffs, NJ: Prentice Hall.
- Chomsky, Noam. 1965. *Aspects of the theory of syntax*. Cambridge, MA: MIT Press.
- Chomsky, Noam. 1973. Conditions on transformations. In Steven Anderson & Paul Kiparsky (eds.), *A festschrift for Morris Halle*, 232–285. New York: Winston.
- Chomsky, Noam. 1981. *Lectures on government and binding*. Berlin & New York: Mouton de Gruyter.
- Chomsky, Noam. 1986. *Barriers* (Linguistic Inquiry Monographs 13). Cambridge, MA: MIT Press.
- Chomsky, Noam. 1995. *The Minimalist program* (Current Studies in Linguistics 28). Cambridge, MA: MIT Press.
- Chomsky, Noam. 2001. Derivation by phase. In Michael Kenstowicz (ed.), *Ken Hale: A life in language* (Current Studies in Linguistics 36), 1–52. Cambridge, MA: MIT Press. DOI: 10.7551/mitpress/4056.001.0001.
- Chomsky, Noam. 2005. On phases. Manuscript. [http://www.fossil.in/Chomsky%5C\\_Phases.pdf](http://www.fossil.in/Chomsky%5C_Phases.pdf).
- Chomsky, Noam. 2008. On phases. In Robert Freidin, David Michaels, Carlos P. Otero & Maria Luisa Zubizarreta (eds.), *Foundational issues in linguistic theory: Essays in honor of Jean-Roger Vergnaud*, 133–165. Cambridge, MA: MIT Press.
- Christensen, Rune H. B. 2019. *Ordinal: Regression models for ordinal data*. R package version 2019.12-10. <https://CRAN.R-project.org/package=ordinal>.
- Cinque, Guglielmo. 1990. *Types of  $\bar{A}$ -dependencies* (Linguistic Inquiry Monographs 17). Cambridge, MA: MIT Press.
- Clark, Herbert H. & Thomas Wasow. 1998. Repeating words in spontaneous speech. *Cognitive Psychology* 37(3). 201–242. DOI: 10.1006/cogp.1998.0693.
- Clifton, Charles & Lyn Frazier. 1989. Comprehending sentences with long distance dependencies. In Gregory N. Carlson & Michael K. Tannenhaus (eds.), *Linguistic structure in language processing*, 272–317. Dordrecht: Kluwer.

## References

- Clifton, Charles, Adrian Staub & Keith Rayner. 2007. Eye movements in reading words and sentences. In Roger P.G. Van Gompel, Martin H. Fischer, Wayne S. Murray & Robin L. Hill (eds.), *Eye Movements*, 341–371. Oxford, UK: Elsevier Science Ltd. DOI: 10.1016/B978-008044980-7/50017-3.
- Clopper, C. J. & E. S. Pearson. 1934. The use of confidence or fiducial limits illustrated in the case of the binomial. *Biometrika* 26(4). 404–413. DOI: 10.1093/biomet/26.4.404.
- Comorovski, Ileana. 1996. *Interrogative phrases and the syntax-semantics interface* (Studies in Linguistics and Philosophy 59). Dordrecht: Kluwer. DOI: 10.1007/978-94-015-8688-7.
- Comrie, Bernard & Tania Kuteva. 2013. Relativization strategies (v2020.3). In Matthew S. Dryer & Martin Haspelmath (eds.), *The world atlas of language structures online*. <https://wals.info/chapter/s8>.
- Conklin, Kathryn, Ana Pellicer-Sanchez & Gareth Carrol. 2018. *Eye-tracking: A guide for applied linguistics research*. Cambridge, UK: Cambridge University Press.
- Copetake, Ann, Dan Flickinger, Carl Pollard & Ivan A. Sag. 2005. Minimal Recursion Semantics. *Research on Language and Computation* 3. 281–332.
- Corver, Norbert. 2006. Freezing effects. In Martin Everaert & Henk C. van Riemsdijk (eds.), *The Blackwell companion to syntax*, 383–406. Oxford, UK: Blackwell.
- Coveney, Aidan B. 1996. *Variability in spoken French: A sociolinguistic study of interrogation and negation*. Exeter: Elm Bank.
- Crysmann, Berthold. 2012. Resumption and island-hood in Hausa. In Philippe de Groote & Mark-Jan Nederhof (eds.), *Formal grammar. 15th and 16th International Conferences. FG 2010, Copenhagen, Denmark, August 2010. FG 2011, Ljubljana, Slovenia, August 2011* (Lecture Notes in Computer Science 7395), 50–65. Berlin: Springer. DOI: 10.1007/978-3-642-32024-8\_4.
- Culicover, Peter W. & Ray Jackendoff. 2005. *Simpler syntax*. Oxford, UK & New York: Oxford University Press.
- Culicover, Peter W. & Kenneth Wexler. 1977. Some syntactic implications of a theory of language learnability. In Peter W. Culicover, Thomas Wasow & Adrian Akmajian (eds.), *Formal syntax*. New York: Academic Press.
- Cuneo, Nicole & Adele E. Goldberg. 2023. The discourse functions of grammatical constructions explain an enduring syntactic puzzle. *Cognition* 240. 105563. DOI: 10.1016/j.cognition.2023.105563.
- Davies, William D. & Stanley Dubinsky. 2009. On the existence (and distribution) of sentential subjects. In Donna B. Gerds, John C. Moore & Maria Polinsky (eds.), *Hypothesis A/hypothesis B: Linguistic explorations in honor of David M.*



- Perlmutter*, 111–128. Cambridge, MA: MIT Press. DOI: 10.7551/mitpress/7670.003.0009.
- De Kuthy, Kordula. 2002. *Discontinuous NPs in German* (Series in Constraint-Based Lexicalism 14). Stanford, CA: CSLI Publications.
- De Kuthy, Kordula. 2021. Information structure. In Stefan Müller, Anne Abeillé, Robert D. Borsley & Jean-Pierre Koenig (eds.), *Head-Driven Phrase Structure Grammar: The handbook* (Empirically Oriented Theoretical Morphology and Syntax 9), 1043–1078. Berlin: Language Science Press. DOI: 10.5281/zenodo.5599864.
- Deane, Paul. 1991. Limits to attention: A cognitive theory of island phenomena. *Cognitive Linguistics* 2(1). 1–63.
- Destruel, Emilie. 2012. The French *c'est*-cleft: An empirical study on its meaning and use. In Christopher Piñon (ed.), *Empirical issues in syntax and semantics 9* (*Selected papers from CSSP 2011*), 95–112. Paris: CSSP. <http://www.cssp.cnrs.fr/eiss9/>.
- Destruel, Emilie, David I. Beaver & Elizabeth Coppock. 2019. It's not what you expected! The surprising nature of cleft alternatives in French and English. *Frontiers in Psychology* 10. 1400. DOI: 10.3389/fpsyg.2019.01400.
- Deulofeu, José. 1981. Perspective linguistique et sociolinguistique dans l'étude des relatives en français. *Recherches sur le français parlé* 3. 135–193.
- de Vries, Mark. 2002. *The syntax of relativization*. LOT dissertation series 53. Amsterdam: University of Amsterdam. (Ph.D. Thesis).
- Dillon, Brian & Matthew Wagers. 2019. *Approaching gradience in acceptability with the tools of signal detection theory*. OSF Preprints. DOI: 10.31219/osf.io/apxru.
- Do, Monica L. & Elsi Kaiser. 2017. The relationship between syntactic satiation and syntactic priming: A first look. *Frontiers in Psychology* 8. 1851. DOI: 10.3389/fpsyg.2017.01851.
- Doetjes, Jenny, Georges Rebuschi & Annie Rialland. 2004. Cleft sentences. In Francis Corblin & Henriëtte de Swart (eds.), *Handbook of French semantics* (CSLI Lecture Notes 170), 529–552. Stanford, CA: CSLI Publications.
- Dong, Zhiyin, Ryan Rhodes & Arild Hestvik. 2021. Active gap filling and island constraint in processing the Mandarin “gap-type” topic structure. *Frontiers in Communication* 6. 650659. DOI: 10.3389/fcomm.2021.650659.
- Downing, Bruce. 1978. Some universals of relative clause structure. In Joseph H. Greenberg (ed.), *Universals of human language*, vol. 4, 375–418. Stanford, CA: Stanford University Press.
- Dowty, David R., Robert Eugene Wall & Stanley Peters. 1981. *Introduction to Montague semantics* (Synthese Language Library 11). Dordrecht: D. Reidel.

## References

- Drummond, Alex. 2010. *Internet Based EXperiments (IBEX)*. <http://spellout.net/ibexfarm>.
- Edwards, Allen L. 1957. *The social desirability variable in personality assessment and research*. New York: Dryden.
- Ehrlich, Susan F. & Keith Rayner. 1981. Contextual effects on word perception and eye movements during reading. *Journal of Verbal Learning and Verbal Behavior* 20(6). 641–655. DOI: 10.1016/S0022-5371(81)90220-6.
- Engdahl, Elisabeth. 1999. Integrating pragmatics into the grammar. In Lunella Mereu (ed.), *Boundaries of morphology and syntax*, 175–194. Amsterdam & Philadelphia: John Benjamins.
- Engdahl, Elisabeth & Enric Vallduví. 1996. Information packaging in HPSG. In Claire Grover & Enric Vallduví (eds.), *Studies in HPSG*, vol. 12 (Edinburgh working papers in cognitive science), 1–31. Edinburgh: Centre for Cognitive Science.
- Erteschik-Shir, Nomi. 1973. *On the nature of island constraints*. MIT Press. (Ph.D. Thesis).
- Erteschik-Shir, Nomi. 1997. *The dynamics of focus structure*. Cambridge, UK: Cambridge University Press.
- Erteschik-Shir, Nomi. 2006. What's what? In Gisbert Fanselow, Caroline Féry, Matthias Schlesewsky & Ralf Vogel (eds.), *Gradience in grammar: Generative perspectives*, 317–335. Oxford, UK & New York: Oxford University Press.
- Erteschik-Shir, Nomi & Shalom Lappin. 1979. Dominance and the functional explanation of island phenomena. *Theoretical Linguistics* 6. 41–86.
- Fadlon, Julie, Adam M. Morgan, Aya Meltzer-Asscher & Victor S. Ferreira. 2019. It depends: Optionality in the production of filler-gap dependencies. *Journal of Memory and Language* 106. 40–76.
- Fodor, Janet D., Stefanie Nickels & Esther Schott. 2017. Center-embedded sentences. In Roberto G. de Almeida & Lila R. Gleitman (eds.), *On concepts, modules, and language: Cognitive science at its core*, 139–168. Oxford, UK & New York: Oxford University Press. DOI: 10.1093/oso/9780190464783.003.0007.
- Francom, Jerid Cole. 2011. *Experimental syntax: Exploring the effect of repeated exposure to anomalous syntactic structure—Evidence from rating and reading tasks*. Proquest, Umi Dissertation Publishing.
- Frazier, Lyn. 1987. Syntactic processing: Evidence from Dutch. *Natural Language & Linguistic Theory* 5. 519–559.
- Frazier, Lyn, Keith Rayner & John A. Hawkins. 1988. Parameterizing the language processing system: Left versus right branching within and across languages. In John A. Hawkins (ed.), *Explaining language universals*, 247–279. Oxford, UK: Blackwell.

- Fukuda, Shin, Grant Goodall, Michel Dan & Henry Beecher. 2012. Is magnitude estimation worth the trouble? In Jaehoon Choi, E. Alan Hogue, Jeffrey Punske, Deniz Tat, Jessamyn Schertz & Alex Trueman (eds.), *Proceedings of the 29th West Coast Conference on Formal Linguistics*. Somerville: Cascadilla Proceedings Project.
- Fukuda, Shin, Chizuru Nakao, Akira Omaki & Maria Polinsky. 2014. Revisiting subject-object asymmetry: Subextraction in Japanese. In Theodore Levin & Ryo Masuda (eds.), *Proceedings of the 10th Workshop on Altaic Formal Linguistics (WAFL10)* (MIT Working Papers in Linguistics 87). Cambridge, MA: Massachusetts Institute of Technology. <http://nrs.harvard.edu/urn-3:HUL.InstRepos:35058853>.
- Gallego, Ángel J. & Juan Uriagereka. 2007. Conditions on sub-extraction. In Luis Eguren & Olga Fernández Soriano (eds.), *Coreference, modality, and focus* (Linguistik Aktuell/Linguistics Today 111), 45–70. Amsterdam & Philadelphia: John Benjamins. DOI: 10.1075/la.111.04gal.
- Gazdar, Gerald. 1981. Unbounded dependencies and coordinate structure. *Linguistic Inquiry* 12(2). 155–184.
- Gennari, Silvia P. & Maryellen C. McDonald. 2008. Semantic indeterminacy in object relative clauses. *Journal of Memory and Language* 58(4). 161–187.
- Gibson, Edward & Evelina Fedorenko. 2013. The need for quantitative methods in syntax and semantics research. *Language and Cognitive Processes* 28. 88–124.
- Gibson, Ted. 1998. Linguistic complexity: Locality of syntactic dependencies. *Cognition* 68. 1–76.
- Gibson, Ted. 2000. The Dependency Locality Theory: A distance-based theory of linguistic complexity. In Alec Marantz, Yasushi Miyashita & Wayne O’Neil (eds.), *Image, language, brain: Papers from the First Mind Articulation Project Symposium*, 95–126. Cambridge, MA: MIT Press.
- Ginzburg, Jonathan & Ivan A. Sag. 2000. *Interrogative Investigations: The form, meaning, and use of English interrogatives*. Stanford, CA: CSLI Publications.
- Giorgi, Alessandra & Giuseppe Longobardi. 1991. *The syntax of noun phrases: Configuration, parameters, and empty categories* (Cambridge Studies in Linguistics 57). Cambridge, UK: Cambridge University Press.
- Godard, Danièle. 1985. French relative clauses with DONT:  $\bar{A}$ -chains and binding principles. In Jacqueline Guéron, Hans-Georg Obenauer & Jean-Yves Pollock (eds.), *Grammatical representation*, 19–42. Dordrecht: Foris.
- Godard, Danièle. 1988. *La syntaxe des relatives en français*. Paris: Ed. du Centre National de la Recherche Scientifique.
- Godard, Danièle. 1992. Extraction out of NP in French. *Natural Language & Linguistic Theory* 10. 233–277.

## References

- Godard, Danièle & Ivan A. Sag. 1996. Quels compléments de nom peut-on extraire en français? *Langages* 122. 60–79.
- Godfrey, John J., Edward C. Holliman & Jane McDaniel. 1992. SWITCHBOARD: Telephone speech corpus for research and development. In *ICASSP-92: IEEE International Conference on Acoustics, Speech, and Signal Processing, San Francisco, CA, USA*, vol. 1, 517–520. Piscataway, NJ: IEEE Service Center.
- Goldberg, Adele E. 2006. *Constructions at work*. Oxford, UK & New York: Oxford University Press.
- Goldberg, Adele E. 2013. Backgrounded constituents cannot be extracted. In Jon Sprouse & Norbert Hornstein (eds.), *Experimental syntax and island effects*, 221–238. Cambridge, UK: Cambridge University Press.
- Goodall, Grant. 2011. Syntactic satiation and the inversion effect in English and Spanish wh-questions. *Syntax* 14(1). 29–47. DOI: 10.1111/j.1467-9612.2010.00148.x.
- Götze, Michael, Thomas Weskott, Cornelia Endriss, Ines Fiedler, Stefan Hinterwimmer, Svetlana Petrova, Anne Schwarz, Stavros Skopeteas & Ruben Stoel. 2007. Information structure. In Stefanie Dipper, Michael Götze & Stavros Skopeteas (eds.), *Information structure in cross-linguistic corpora: Annotation guidelines for phonology, morphology, syntax, semantics and information structure* (Interdisciplinary Studies on Information Structure 7), 147–187. Potsdam: Universitätsverlag Potsdam. <https://nbn-resolving.org/urn:nbn:de:kobv:517-opus-14199>.
- Greco, Ciro, Marco Marelli & Liliane Haegeman. 2017. External syntax and the cumulative effect in subject sub-extraction: An experimental evaluation. *The Linguistic Review* 34(3). 479–531. DOI: 10.1515/trlr-2017-0009.
- Grice, Paul H. 1975. Logic and conversation. In Peter Cole & Jerry L. Morgan (eds.), *Studies in syntax and semantics III: Speech acts*, 183–98. New York: Academic Press.
- Gries, Stefan Th. 2002. Preposition stranding in English: Predicting speakers' behaviour. In Vida Samiian & Vida Samiian (eds.), *Proceedings of the Western Conference on Linguistics 2000*, vol. 12, 230–241.
- Grosu, Alexander. 1981. *Approaches to island phenomena* (North-Holland Linguistic Series 45). Amsterdam: North-Holland.
- Guéron, Jacqueline. 1980. On the syntax and semantics of PP extraposition. *Linguistic Inquiry* 11(4). 637–678.
- Gundel, Jeanette K. 1974. *The role of topic and comment in linguistic theory*. University of Texas. (Ph.D. Thesis).
- Gundel, Jeanette K. 1988. *The role of topic and comment in linguistic theory*. New York: Garland Publishing.

- Gussenhoven, Carlos. 2007. Types of focus in English. In Chungmin Lee, Matthew Gordon & Daniel Büring (eds.), *Topic and focus: Cross-linguistic perspectives on meaning and intonation* (Studies in Linguistics and Philosophy 82), 83–100. Dordrecht: Springer. DOI: 10.1007/978-1-4020-4796-1\_5.
- Guzmán Naranjo, Matías. 2015. Unifying everything: Integrating quantitative effects into formal models of grammar. In Johannes Wahle, Marisa Köllner, Harald Baayen, Gerhard Jäger & Tineke Baayen-Oudshoorn (eds.), *Proceedings of the 6th Conference on Quantitative Investigations in Theoretical Linguistics*. DOI: 10.15496/PUBLIKATION-8636.
- Haegeman, Liliane, Ángel L. Jiménez-Fernández & Andrew Radford. 2014. Deconstructing the subject condition in terms of cumulative constraint violation. *The Linguistic Review* 31. 73–150.
- Hale, John T. 2001. A probabilistic Earley parser as a psycholinguistic model. In *Second meeting of the North American chapter of the Association for Computational Linguistics*. <https://aclanthology.org/N01-1021>.
- Hartig, Florian. 2019. *DHARMa: Residual Diagnostics for Hierarchical (Multi-Level / Mixed) Regression Models*. R package version 0.2.2. <https://CRAN.R-project.org/package=DHARMa>.
- Hawkins, John A. 1999. Processing complexity and filler-gap dependencies across grammars. *Language* 75(2). 244. DOI: 10.2307/417261.
- Heaton, Raina, Kamil Deen & William O’Grady. 2016. The status of syntactic ergativity in Kaqchikel. *Lingua* 170. 35–46. DOI: 10.1016/j.lingua.2015.10.006.
- Heck, Fabian. 2009. On certain properties of pied-piping. *Linguistic Inquiry* 40(1). 75–111. DOI: 10.1162/ling.2009.40.1.75.
- Herschensohn, Julia. 1992. Case marking and French psych-verbs. *Linguisticae Investigationes* 15(1). 21–40.
- Hirschbühler, Paul & Daniel Valois. 1992. Argument extraction out of indirect questions in French. In Helen Goodluck & Michael Rochemont (eds.), *Island constraints* (Studies in Theoretical Psycholinguistics 15), 195–222. Dordrecht: Springer. DOI: 10.1007/978-94-017-1980-3\_7.
- Hoffmann, Thomas. 2005. Variable vs. categorical effects: Preposition pied piping and stranding in British English relative clauses. *Journal of English Linguistics* 33(3). 257–297. DOI: 10.1177/0075424205282891.
- Hoffmann, Thomas. 2008. English relative clauses and Construction Grammar: A topic which preposition placement can shed light on? In *English relative clauses and Construction Grammar*: 77–112. De Gruyter Mouton. DOI: 10.1515/9783110199178.2.77.

## References

- Hoffmann, Thomas. 2011. *Preposition placement in English: A usage-based approach*. Cambridge: Cambridge University Press. DOI: 10.1017/CBO9780511933868.
- Hofmeister, Philip, Laura Staum Casasanto & Ivan A. Sag. 2013. Islands in the grammar? Standards of evidence. In Jon Sprouse & Norbert Hornstein (eds.), *Experimental syntax and island effects*, 42–63. Cambridge, UK: Cambridge University Press.
- Hofmeister, Philip & Ivan A. Sag. 2010. Cognitive constraints and island effects. *Language* 86(2). 366–415.
- Holmes, Virginia M. & J. Kevin O'Reagan. 1981. Eye fixation patterns during the reading of relative-clause sentences. *Journal of Verbal Learning and Verbal Behaviour* 20. 417–430.
- Horn, George. 1972. Generalizing the Sentential Subject Constraint. *North-East Linguistic Society* 3.
- Huang, Cheng-Teh J. 1982. *Logical relations in Chinese and the theory of grammar*. MIT. (Ph.D. Thesis). <https://www.jstor.org/stable/4178404>.
- Huang, Cheng-Teh J. 1984. On the distribution and reference of empty pronouns. *Linguistic Inquiry* 15(4). 531–574.
- Huddleston, Ronald & Geoffrey Pullum (eds.). 2002. *The Cambridge grammar of the English language*. Cambridge, UK: Cambridge University Press.
- Hudson, Richard A. 2010. *An introduction to word grammar*. Cambridge, UK: Cambridge University Press. DOI: 10.1017/CBO9780511781964.
- Hukari, Thomas E. & Robert D. Levine. 1995. Adjunct extraction. *Journal of Linguistics* 31(2). 195–226.
- Hyams, Nina & Kenneth Wexler. 1993. On the grammatical basis of null subjects in child language. *Linguistic Inquiry* 24(3). 421–459. <http://www.jstor.org/stable/4178822>.
- Jackendoff, Ray. 1977. *X̄ Syntax: A study of phrase structure* (Linguistic Inquiry Monographs 2). Cambridge, MA: MIT Press.
- Jacobs, Joachim. 2001. The dimensions of topic-comment. *Linguistics* 39. 641–681.
- Jiménez-Fernández, Angel. 2009. On the composite nature of subject islands: A phase-based approach. *SKY Journal of Linguistics* 22. 91–138.
- Johansson, Christine & Christer Geisler. 1998. Pied piping in spoken English. In Antoinette Renouf (ed.), *Explorations in Corpus Linguistics*, 67–82. Amsterdam: Rodopi.
- Jurka, Johannes. 2010. *The importance of being a complement*. University of Maryland. (Ph.D. Thesis).



- Jurka, Johannes, Chizuru Nakao & Akira Omaki. 2011. It's not the end of the CED as we know it: Revisiting German and Japanese subject islands. In Mary Byram Washburn, Katherine McKinney-Bock, Erika Varis, Ann Sawyer & Barbara Tomaszewicz (eds.), *Proceedings of the 28th West Coast Conference on Formal Linguistics*, 124–132. Somerville: Cascadilla Proceedings Project.
- Just, Marcel A. & Patricia A. Carpenter. 1980. A theory of reading: From eye fixations to comprehension. *Psychological Review* 87(4). 329–354. DOI: 10.1037/0033-295X.87.4.329.
- Just, Marcel A., Patricia A. Carpenter & Jacqueline D. Woolley. 1982. Paradigms and processes in reading comprehension. *Journal of Experimental Psychology: General* 111(2). 228.
- Kaan, Edith, Anthony Harris, Edward Gibson & Phillip Holcomb. 2000. The P600 as an index of syntactic integration difficulty. *Language and Cognitive Processes* 15(2). 159–201.
- Kaiser, Georg & Stefano Quaglia. 2015. In search of wh-in-situ in Romance: An investigation in detective stories. In Ellen Brandner, Anna Czypionka, Constantin Freitag & Andreas Trotzke (eds.), *Charting the landscape of linguistics: On the scope of Josef Bayer's work*, 92–103.
- Karssenber, Lena & Karen Lahousse. 2018. The information structure of French *il y a* clefts and *c'est* clefts: A corpus-based analysis. *Linguistics* 56(3). 513–548. DOI: 10.1515/ling-2018-0004.
- Kayne, Richard S. 1974. French relative *que*. *Recherches Linguistiques de Vincennes* 2&3. 40–61 & 27–92.
- Kayne, Richard S. 1975. *French syntax: The transformational cycle* (Current Studies in Linguistics 6). Cambridge, MA: MIT Press.
- Kayne, Richard S. 1976. French relative *que*. In Marta Luján & Frederick Gerald H. (eds.), *Current studies in Romance linguistics*, 255–299. Washington: Georgetown University Press.
- Kayne, Richard S. 1981. ECP extensions. *Linguistic Inquiry* 12(1). 93–133. <http://www.jstor.org/stable/4178206>.
- Kayne, Richard S. 1983. Connectedness. *Linguistic Inquiry* 14. 223–249. <https://www.jstor.org/stable/4178324>.
- Keenan, Edward L. & Bernard Comrie. 1977. Noun phrase accessibility and universal grammar. *Linguistic Inquiry* 8(1). 63–99. <http://www.jstor.org/stable/4177973>.
- Keller, Frank. 2000. *Gradience in grammar: Experimental and computational aspects of degrees of grammaticality*. University of Edinburgh. (Ph.D. Thesis).

## References

- Keller, Frank. 2001. Experimental evidence for constraint competition in gapping constructions. In Gereon Müller & Wolfgang Sternefeld (eds.), *Competition in syntax*, 211–248. Berlin & New York: Mouton de Gruyter.
- Kemper, Susan. 1986. Imitation of complex syntactic constructions by elderly adults. *Applied Psycholinguistics* 7(3). 277–287. DOI: 10.1017/S0142716400007578.
- Kemper, Susan. 1987. Life-span changes in syntactic complexity. *Journal of Gerontology* 42(3). 323–328. DOI: 10.1093/geronj/42.3.323.
- Keshev, Maayan & Aya Meltzer-Asscher. 2019. A processing-based account of subliminal wh-island effects. *Natural Language & Linguistic Theory* 37(2). 621–657.
- Kim, Jong-Bok. 2012. On the syntax of the it-cleft construction: A construction-based perspective. *Linguistic Research* 29(1). 45–68.
- Kim, Jong-Bok & Ivan A. Sag. 2002. Negation without head-movement. *Natural Language & Linguistic Theory* 20(2). 339–412.
- Kiss, Tibor. 2005. Semantic constraints on relative clause extraposition. *Natural Language & Linguistic Theory* 23(2). 281–334.
- Kitagawa, Yoshi. 1986. *Subjects in Japanese and English*. University of Massachusetts. (Ph.D. Thesis).
- Kluender, Robert. 1991. *Cognitive constraint on variables in syntax*. San Diego: University of California. (Ph.D. Thesis).
- Kluender, Robert. 1998. On the distinction between strong and weak islands: A processing perspective. In Peter W. Culicover & Louise McNally (eds.), *The limits of syntax*, 241–279. New York: Academic Press.
- Kluender, Robert. 2004. Are subject islands subject to a processing account? In Vineeta Chand, Ann Kelleher, Angelo J. Rodríguez & Benjamin Schmeiser (eds.), *Proceedings of the 23rd West Coast Conference on Formal Linguistics*, vol. 23, 101–125. Somerville: Cascadilla Press.
- Kluender, Robert & Marta Kutas. 1993a. Bridging the gap: Evidence from ERPs on the processing of unbounded dependencies. *Journal of Cognitive Neuroscience* 5(2). 196–214.
- Kluender, Robert & Marta Kutas. 1993b. Subjacency as a processing phenomenon. *Language and Cognitive Processes* 8. 573–633.
- Kobzeva, Anastasia, Charlotte Sant, Parker T. Robbins, Myrte Vos, Terje Lohndal & Dave Kush. 2022. Comparing island effects for different dependency types in Norwegian. *Languages* 7(3). 197. DOI: 10.3390/languages7030197.
- Kolliakou, Dimitra. 1999. De-phrase extractability and individual/property denotation. *Natural Language & Linguistic Theory* 17. 713–781.



- König, Esther & Wolfgang Lezius. 2003. *The TIGER language: A description language for syntax graphs, formal definition*. Technical report IMS. Stuttgart: Universität Stuttgart.
- Koopman, Hilda & Dominique Sportiche. 1991. The position of subjects. *Lingua* 85. 211–258.
- Koopman, Hilda & Dominique Sportiche. 2014. The que/qui alternation. In Peter Svenonius (ed.), *Functional structure from top to toe*, 46–96. Oxford, UK & New York: Oxford University Press. DOI: 10.1093/acprof:oso/9780199740390.003.0003.
- Kratzer, Angelika. 1996. Severing the external argument from its verb. In Johan Rooryck & Laurie Zaring (eds.), *Phrase structure and the lexicon* (Studies in Natural Language and Linguistic Theory 33), 109–137. Dordrecht: Springer. DOI: 10.1007/978-94-015-8617-7\_5.
- Krifka, Manfred. 1992. A compositional semantics for multiple focus constructions. In Joachim Jacobs (ed.), *Informationsstruktur und Grammatik*, 17–53. Opladen: Westdeutscher Verlag.
- Krifka, Manfred. 2007. Basic notions of information structure. In Gisbert Fanselow Caroline Féry & Manfred Krifka (eds.), *The notions of information structure* (Interdisciplinary Studies on Information Structure 6), 13–56. Potsdam: Universitätsverlag Potsdam. <https://nbn-resolving.org/urn:nbn:de:kobv:517-opus-15472>.
- Kuno, Susumu. 1972. Functional sentence perspective: A case study from Japanese and English. *Linguistic Inquiry* 3. 269–320. <https://www.jstor.org/stable/4177715>.
- Kuno, Susumu. 1973. *The structure of the Japanese language*. Cambridge, MA: The MIT Press.
- Kuno, Susumu. 1976. Subject, theme, and the speaker's empathy: A reexamination of relativization phenomena. In Charles N. Li (ed.), *Subject and topic*, 417–444. New York: Academic Press.
- Kuno, Susumu. 1987. *Functional syntax: Anaphora, discourse and empathy*. Chicago & London: The University of Chicago Press.
- Kuroda, Sige-Yuki. 1976. Subject. In Masayoshi Shibatani (ed.), *Japanese generative grammar* (Syntax and Semantics 5), 1–16. New York: Academic Press.
- Kush, Dave & Anne Dahl. 2022. L2 transfer of L1 island-insensitivity: The case of Norwegian. *Second Language Research* 38(2). 315–346. DOI: 10.1177/0267658320956704.
- Kush, Dave, Terje Lohndal & Jon Sprouse. 2018. Investigating variation in island effects. *Natural Language & Linguistic Theory* 36(3). 743–779. DOI: 10.1007/s11049-017-9390-z.

## References

- Kush, Dave, Terje Lohndal & Jon Sprouse. 2019. On the island sensitivity of topicalization in Norwegian: An experimental investigation. *Language* 95(3). 393–420.
- Kynette, Donna & Susan Kemper. 1986. Aging and the loss of grammatical forms: A cross-sectional study of language performance. *Language & Communication* 6(1). 65–72. DOI: 10.1016/0271-5309(86)90006-6.
- Labelle, Marie. 1992. Change of state and valency. *Journal of Linguistics* 28. 375–414.
- Ladusaw, William A. 1994. Thetic and categorial, stage and individual, weak and strong. In Mandy Harvey & Lynn Santelmann (eds.), *Proceedings of SALT IV*, 220–229. Ithaca, NY: Cornell U. DMLL.
- Lahousse, Karen. 2011. *Quand passent les cigognes : Le sujet nominal postverbal en français moderne* (Sciences du Langage). Vincennes: Presses Univ. de Vincennes.
- Lakoff, George. 1973. Fuzzy grammar and the performance/competence terminology game. In Claudia T. Corum, Cedric Smith-Stark & Ann Weiser (eds.), *Papers from the ninth Regional Meeting of the Chicago Linguistic Society*, 271–291. Chicago: Chicago Linguistic Society.
- Lambrecht, Knud. 1994. *Information structure and sentence form: Topic, focus, and the mental representations of discourse referents* (Cambridge Studies in Linguistics 71). Cambridge, UK: Cambridge University Press.
- Landau, Idan. 2010. *The locative syntax of experiencers* (Linguistic Inquiry Monographs 53). Cambridge, MA: MIT Press.
- Larrivée, Pierre. 2016. *Les interrogatives in-situ sont-elles pragmatiquement marquées en français vernaculaire ? Investigation synchronique et historique*. Ludwig Maximilians Universität München.
- Lascarides, Alex & Ann Copestake. 1999. Default representation in constraint-based frameworks. *Computational Linguistics* 25(1). 55–105.
- Lasnik, Howard & Mamoru Saito. 1992. *Move  $\alpha$ : Conditions on its applications and output* (Current Studies in Linguistics 22). Cambridge, MA: MIT Press.
- Le Goffic, Pierre. 2007. Les mots qu- entre interrogation, indéfinition et subordination : Quelques repères. *Lexique* 18. 13–46.
- Lee, Seung Han. 2018. English sentential subject extraposition: A constraint-based approach. *The Linguistic Association of Korea Journal* 26(3). 71–87. [http://www.kci.go.kr/kciportal/landing/article.kci?arti%5C\\_id=ART002394400](http://www.kci.go.kr/kciportal/landing/article.kci?arti%5C_id=ART002394400) (12 August, 2020).
- Legendre, Géraldine. 1989. Inversion with certain French experiencer verbs. *Language* 65(4). 752–782.

- Legendre, Géraldine & Antonella Sorace. 2003. Auxiliaires et intransitivité en français et dans les langues romanes. In Danièle Godard (ed.), *Les langues romanes*, 185–233. Paris: CNRS Editions.
- Levine, Robert D. & Ivan A. Sag. 2003. Some empirical issues in the grammar of extraction. In Stefan Müller (ed.), *Proceedings of the 10th International Conference on Head-Driven Phrase Structure Grammar, Michigan State University*, 236–256. Stanford, CA: CSLI Publications. DOI: 10.21248/hpsg.2003.14.
- Lewis, Richard L. & Shravan Vasishth. 2005. An activation-based model of sentence processing as skilled memory retrieval. *Cognitive Science* 29. 375–419.
- Liu, Haitao. 2008. Dependency distance as a metric of language comprehension difficulty. *Journal of Cognitive Science* 9(2). 159–191. DOI: 10.17791/JCS.2008.9.2.159.
- Liu, Haitao, Richard Hudson & Zhiwei Feng. 2009. Using a Chinese treebank to measure dependency distance. *Corpus Linguistics and Linguistic Theory* 5(2). 161–175.
- Liu, Yingtong, Rachel Ryskin, Richerd Futrell & Edward Gibson. 2019. Verb frequency explains the unacceptability of factive and manner-of-speaking islands in English. In *COGSCI'19*, 686–691. Montreal.
- Liu, Yingtong, Elodie Winckel, Anne Abeillé, Barbara Hemforth & Edward Gibson. 2022. Structural, functional and processing perspectives on linguistic island effects. *Annual Review of Linguistics* 8. 1089391248. DOI: 10.1146/annurev-linguistics-011619-030319.
- Longobardi, Giuseppe. 1984. Some remarks on connectedness and c-command. In Wim De Geest & Yvan Putseys (eds.), *Sentential complementation*, 151–164. Berlin & New York: Mouton de Gruyter.
- Longobardi, Giuseppe. 1985. Connectedness, scope, and c-command. *Linguistic Inquiry* 16. 163–192. <https://www.jstor.org/stable/4178429>.
- Lu, Jiayi, Cynthia K. Thompson & Masaya Yoshida. 2020. Chinese wh-in-situ and islands: A formal judgment study. *Linguistic Inquiry* 51(3). 611–623. DOI: 10.1162/ling\_a\_00343.
- Machicao y Priemer, Antonio & Elodie Winckel. 2015. *Adjectives within Spanish and French NPs: Position and interpretation*. Poster at the 22nd International Conference on Head-Driven Phrase Structure Grammar in Nanyang Technological University. Singapore.
- Marandin, Jean-Marie. 2008. The exclamative clause type in French. In Stefan Müller (ed.), *Proceedings of the 15th International Conference on Head-Driven Phrase Structure Grammar, National Institute of Information and Communications Technology, Keihanna*, 436–456. Stanford: CSLI Publications. DOI: 10.21248/hpsg.2008.25.

## References

- Marandin, Jean-Marie. 2011. Subject inversion in French: The limits of information structure. In Stefan Müller (ed.), *Proceedings of the 18th International Conference on Head-Driven Phrase Structure Grammar, University of Washington*, 327–347. Stanford, CA: CSLI Publications. DOI: 10.21248/hpsg.2011.19.
- Marandin, Jean-Marie, Danièle Godard, Laurent Roussarie & Francis Corblin. 2007. Thème de phrase. In Danièle Godard, Laurent Roussarie & Francis Corblin (eds.), *Sémanticlopédie*. GDR Sémantique et Modélisation. [http://www.semantique-gdr.net/dico/index.php/Th%5C%C3%5C%A8me%5C\\_de%5C\\_phrase](http://www.semantique-gdr.net/dico/index.php/Th%5C%C3%5C%A8me%5C_de%5C_phrase).
- Melis, Ludo. 1988. Les propositions enchevêtrées, des complétives ou des relatives-interrogatives? *Neuphilologische Mitteilungen* 67. 189–196. <https://www.jstor.org/stable/43343855>.
- Mensching, Guido. 2000. *Infinitive constructions with specified subjects: A syntactic analysis of the Romance languages* (Oxford studies in comparative syntax). Oxford, UK & New York: Oxford University Press.
- Mensching, Guido, Stefan Müller, Franziska Werner & Elodie Winckel. 2018. *Asymmetries in long distance dependencies in French*. Talk at the 40. Jahrestagung der Deutschen Gesellschaft für Sprachwissenschaft in Stuttgart.
- Miles, Walter R. 1930. Ocular dominance in human adults. *The Journal of General Psychology* 3(3). 412–430. DOI: 10.1080/00221309.1930.9918218.
- Miller, Philip. 2001. Discourse constraints on (non)extraposition from subject in English. *Linguistics* 39(4). 683–701. DOI: 10.1515/ling.2001.028.
- Miller, Philip & Ivan A. Sag. 1997. French clitic movement without clitics or movement. *Natural Language & Linguistic Theory* 15. 573–639.
- Milner, Jean Claude. 1978. *De la syntaxe à l'interprétation: Quantités, insultes, exclamations*. Paris: Seuil.
- Momma, Shota & Colin Phillips. 2018. The relationship between parsing and generation. *Annual Review of Linguistics* 4. 233–254.
- Momma, Shota, Masaya Yoshida & Victor Ferreira. 2019. *Structure before content: Long-distance dependency in sentence production*. Talk at the 32nd Annual CUNY Conference on Human Sentence Processing in Boulder, CO. Boulder, CO. [https://www.colorado.edu/event/cuny2019/sites/default/files/attached-files/talk%5C\\_momma%5C\\_etal.pdf](https://www.colorado.edu/event/cuny2019/sites/default/files/attached-files/talk%5C_momma%5C_etal.pdf) (18 March, 2020).
- Müller, Gereon. 1998. *Incomplete category fronting: A derivational approach to remnant movement in German* (Studies in Natural Language & Linguistic Theory 42). Dordrecht: Kluwer.
- Müller, Stefan. 2015. The CoreGram Project: Theoretical linguistics, theory development and verification. *Journal of Language Modelling* 3(1). 21–86.

- Müller, Stefan. 2016. *Grammatical theory: From transformational grammar to constraint-based approaches* (Textbooks in Language Sciences 1). Berlin: Language Science Press. DOI: 10.17169/langsci.b25.167.
- Müller, Stefan. 2017. Head-Driven Phrase Structure Grammar, Sign-Based Construction Grammar, and Fluid Construction Grammar: Commonalities and differences. *Constructions and Frames* 9(1). 139–173. DOI: 10.1075/cf.9.1.05mul.
- Müller, Stefan, Anne Abeillé, Robert D. Borsley & Jean-Pierre Koenig (eds.). 2021. *Head-Driven Phrase Structure Grammar: The handbook* (Empirically Oriented Theoretical Morphology and Syntax 9). Berlin: Language Science Press. DOI: 10.5281/zenodo.5543318.
- Müller, Stefan, Felix Bildhauer & Philippa Cook. 2020. Information structure constraints on multiple frontings. In Stefan Müller (ed.), *German clause structure: An analysis with special consideration of so-called multiple fronting*. Manuscript.
- Müller, Stefan & Walter Kasper. 2000. HPSG analysis of German. In Wolfgang Wahlster (ed.), *Verbmobil: Foundations of speech-to-speech translation*, 238–253. Berlin: Springer. DOI: 10.1007/978-3-662-04230-4\_17.
- Norman, Suzanne, Susan Kemper & Donna Kynette. 1992. Adults' reading comprehension: Effects of syntactic complexity and working memory. *Journal of Gerontology* 47(4). 258–265. DOI: 10.1093/geronj/47.4.P258.
- Nunes, Jairo & Juan Uriagereka. 2000. Cyclicity and extraction domains. *Syntax* 3. 20–43.
- Obenauer, Hans-Georg. 1976. *Etudes de syntaxe interrogative du français* (Linguistische Arbeiten 34). Berlin & New York: Mouton de Gruyter.
- Osborne, Timothy. 2019. *A dependency grammar of English: An introduction and beyond*. Amsterdam & Philadelphia: John Benjamins. DOI: 10.1075/z.224.
- Pañeda, Claudia, Sol Lago, Elena Vares, João Veríssimo & Claudia Felser. 2020. Island effects in Spanish comprehension. *Glossa: A Journal of General Linguistics* 5(1). 21. DOI: 10.5334/gjgl.1058.
- Pechmann, Thomas, Hans Uszkoreit, Johannes Engelkamp & Dieter Zerbst. 1994. *Word order in the German middle field: Linguistic theory and psycholinguistic evidence* (CLAUS Report 43). Saarbrücken: Department of Computational Linguistics, Saarland University.
- Perlmutter, David M. 1978. Impersonal passives and the unaccusative hypothesis. In *Proceedings of the Fourth Annual Meeting of the Berkeley Linguistics Society*, 157–189. Berkeley: Berkeley Linguistics Society.
- Pesetsky, David. 1982. Complementizer-trace phenomena and the nominative island condition. *The Linguistic Review* 1. 297–343.

## References

- Pesetsky, David. 1987. Wh-in situ: Movement and unselective binding. In Eric J. Reuland & Alice G. B. ter Meulen (eds.), *The representation of (in)definiteness* (Current Studies in Linguistics 14), 98–129. Cambridge, MA: MIT Press.
- Phillips, Colin. 2006. The real-time status of island phenomena. *Language* 82(4). 795–823.
- Pickering, Martin J. & Guy Barry. 1991. Sentence processing without empty categories. *Language and Cognitive Processes* 6(3). 229–259. DOI: 10.1080/01690969108406944.
- Pizarro-Guevara, Jed Sam & Matthew Wagers. 2020. The predictive value of Tagalog voice morphology in filler-gap dependency formation. *Frontiers in Psychology* 11. DOI: 10.3389/fpsyg.2020.00517.
- Polinsky, Maria, Carlos G. Gallo, Peter Graff, Ekaterina Kravtchenko, Adam Milton Morgan & Anne Sturgeon. 2013. Subject islands are different. In Jon Sprouse & Norbert Hornstein (eds.), *Experimental syntax and island effects*, 286–309. Cambridge, UK: Cambridge University Press.
- Pollard, Carl J. 1984. *Generalized Phrase Structure Grammars, Head Grammars, and natural language*. Stanford University. (Ph.D. Thesis).
- Pollard, Carl J. & Andrew M. Moshier. 1990. Unifying partial descriptions of sets. In Philip P. Hanson (ed.), *Information, language and cognition* (Vancouver Studies in Cognitive Science 1), 285–322. Vancouver: University of British Columbia Press.
- Pollard, Carl J. & Ivan A. Sag. 1994. *Head-Driven Phrase Structure Grammar*. Stanford, CA: CSLI Publications.
- Portner, Paul & Katsuhiko Yabushita. 1998. The semantics and pragmatics of topic phrases. *Linguistics and Philosophy* 21(2). 117–157. DOI: 10.1023/A:1005311504497.
- Pozniak, Céline & Barbara Hemforth. 2015. *Processing subject and object relative clauses in French and Mandarin Chinese*. Poster at the 28th Annual CUNY Sentence Processing Conference in Los Angeles.
- Prince, Ellen. 1978. A comparison of wh-clefts and it-clefts in discourse. *Language* 54. 883–906.
- Przepiórkowski, Adam. 2016. How *not* to distinguish arguments from adjuncts in LFG. In Doug Arnold, Miriam Butt, Berthold Crysmann, Tracy Holloway King & Stefan Müller (eds.), *Proceedings of the Joint 2016 Conference on Head-driven Phrase Structure Grammar and Lexical Functional Grammar, Polish Academy of Sciences, Warsaw, Poland*, 560–580. Stanford, CA: CSLI Publications. DOI: 10.21248/hpsg.2016.29.
- Quammen, David. 1985. *Natural acts: A sidelong view of science and nature*. New York: Laurel.



- R Core Team. 2018. *R: A language and environment for statistical computing*. R Foundation for Statistical Computing, Vienna, Austria. <https://www.R-project.org/>.
- Radford, Andrew. 2009. *Analysing English sentences: A minimalist approach*. Cambridge, UK: Cambridge University Press. DOI: 10.1017/CBO9780511801617.
- Rayner, Keith & Susan A. Duffy. 1986. Lexical complexity and fixation times in reading: Effects of word frequency, verb complexity, and lexical ambiguity. *Memory & Cognition* 14(3). 191–201. DOI: 10.3758/BF03197692.
- Rayner, Keith, Gary E. Raney & Alexander Pollatsek. 1995. Eye movements and discourse processing. In Robert Frederick Lorch Jr. & Edward J. O'Brien (eds.), *Sources of coherence in reading*, 9–35. Hillsdale, NJ: Routledge.
- Reinhart, Tanya. 1982. Pragmatics and linguistics: An analysis of sentence topics. *Philosophica* 27. 53–94.
- Reinhart, Tanya. 1997. Wh-in-situ in the framework of the Minimalist program. *Natural Language Semantics* 6(1). 29–56. DOI: 10.1023/A:1008240014550.
- Richter, Frank. 2000. *A mathematical formalism for linguistic theories with an application in Head-Driven Phrase Structure Grammar*. Eberhard-Karls-Universität Tübingen. (Ph.D. Thesis). <http://w210.ub.uni-tuebingen.de/dbt/volltexte/2004/1203/>.
- Riou, Etienne & Barbara Hemforth. 2018. Contrainte du doublage clitique et détachement de l'objet à gauche. *6e Congrès Mondial de Linguistique Française* (46). 01005. DOI: 10.1051/shsconf/20184601005.
- Rizzi, Luigi. 1982. *Issues in Italian syntax* (Studies in generative grammar 11). Dordrecht: Foris.
- Rizzi, Luigi. 1990. *Relativized minimality* (Linguistic Inquiry Monographs 16). Cambridge, MA: MIT Press.
- Robin, Xavier, Natacha Turck, Alexandre Hainard, Natalia Tiberti, Frédérique Lisacek, Jean-Charles Sanchez & Markus Müller. 2011. pROC: An open-source package for R and S+ to analyze and compare ROC curves. *BMC Bioinformatics* 12. 77.
- Rooth, Mats. 1992. A theory of focus interpretation. *Natural Language Semantics* 1. 75–116.
- Ross, Haj. 1987. Islands and syntactic prototypes. In Anna Bosch, Barbara Need & Eric Schiller (eds.), *Papers from the Twenty-Third Regional Meeting of the Chicago Linguistic Society*, 309–320. Chicago: Chicago Linguistic Society.
- Ross, John Robert. 1967. *Constraints on variables in syntax*. Cambridge, MA: MIT Press. (Ph.D. Thesis). DOI: 1721.1/15166.
- Sag, Ivan A. 1997. English relative clause constructions. *Journal of Linguistics* 33(2). 431–484.

## References

- Sag, Ivan A. 2010. English filler-gap constructions. *Language* 86(3). 486–545.
- Sag, Ivan A. & Janet D. Fodor. 1994. Extraction without traces. In Raul Aranovich, William Byrne, Susanne Preuss & Martha Senturia (eds.), *Proceedings of the thirteenth West Coast Conference on Formal Linguistics*, 365–384. Stanford: CSLI Publications.
- Sag, Ivan A. & Janet D. Fodor. 1996. Une analyse sans catégorie vide des phénomènes d'extraction. *Langages* 122. 8–31. DOI: 10.3406/lgge.1996.1747.
- Sag, Ivan A. & Danièle Godard. 1994. Extraction of *de*-phrases from the French NP. In *Proceedings of the North East Linguistic Society 24*, 519–541. Amherst, MA: GLSA. <http://lingo.stanford.edu/sag/papers/is-dg-nelspaper.pdf>.
- Sag, Ivan A., Philip Hofmeister & Neal Snider. 2007. Processing complexity in Subjacency violations: The complex noun phrase constraint. In *Proceedings of the 43rd Annual Meeting of the Chicago Linguistic Society*, vol. 43, 215–229. Chicago: Chicago Linguistic Society.
- Santorini, Beatrice. 2017. *(Un?)expected movement*. Homepage. <http://www.ling.upenn.edu/~beatrice/examples/movement.html>.
- Schachter, Paul. 1973. Focus and relativization. *Language* 49(1). 19–46. DOI: 10.2307/412101.
- Schlonsky, Ur. 2012. Notes on wh in situ in French. In Laura Brugè, Anna Cardinaletti, Giuliana Giusti, Nicola Munar & Cecilia Poletto (eds.), *Functional heads (The cartography of syntactic structures 7)*, 242–252. Oxford, UK & New York: Oxford University Press.
- Schlueter, Zoe, Dan Parker & Ellen Lau. 2019. Error-driven retrieval in agreement attraction rarely leads to misinterpretation. *Frontiers in Psychology* 10. DOI: 10.3389/fpsyg.2019.01002.
- Schneider, Walter, Amy Eschman & Anthony Zuccolotto. 2012. *E-prime reference guide*. Pittsburgh.
- Schütze, Carson T. 2016. *The empirical base of linguistics: Grammaticality judgments and linguistic methodology (Classics in Linguistics 2)*. Berlin: Language Science Press. DOI: 10.17169/langsci.b89.100.
- Simonenko, Alexandra. 2016. Semantics of DP islands: The case of questions. *Journal of Semantics* 33(4). 661–702. DOI: 10.1093/jos/ffv011.
- Song, Sanghoun. 2016. A multilingual grammar model of honorification: Using the HPSG and MRS formalism. *Language and Information* 20(1). 25–49.
- Song, Sanghoun. 2017. *Modeling information structure in a cross-linguistic perspective (Topics at the Grammar-Discourse Interface 1)*. Berlin: Language Science Press. DOI: 10.5281/zenodo.818365.



- Song, Sanghoun & Emily M. Bender. 2012. Individual constraints for information structure. In Stefan Müller (ed.), *Proceedings of the 19th International Conference on Head-Driven Phrase Structure Grammar, Chungnam National University Daejeon*, 330–348. DOI: 10.21248/hpsg.2012.19.
- Sorace, Antonella & Frank Keller. 2005. Gradience in linguistic data. *Lingua* 115(11). 1497–1524. DOI: 10.1016/j.lingua.2004.07.002.
- Sportiche, Dominique. 1981. Bounding nodes in French. *The Linguistic Review* 1(2). 219–246.
- Sportiche, Dominique. 1998. *Partitions and atoms of clause structure: Subjects, agreement, case, and clitics* (Routledge Leading Linguists 2). London & New York: Routledge.
- Sprouse, Jon. 2007a. *A program for experimental syntax: Finding the relationship between acceptability and grammatical knowledge*. University of Maryland. (Ph.D. Thesis).
- Sprouse, Jon. 2007b. Continuous acceptability, categorical grammaticality, and experimental syntax. *Biolinguistics* 1. 118–129.
- Sprouse, Jon. 2009. Revisiting satiation: Evidence for an equalization response strategy. *Linguistic Inquiry* 40(2). 329–341. DOI: 10.1162/ling.2009.40.2.329.
- Sprouse, Jon & Diego Almeida. 2017. Design sensitivity and statistical power in acceptability judgment experiments. *Glossa: A Journal of General Linguistics* 2. 14. DOI: 10.5334/gjgl.236.
- Sprouse, Jon, Ivano Caponigro, Ciro Greco & Carlo Cecchetto. 2016. Experimental syntax and the variation of island effects in English and Italian. *Natural Language & Linguistic Theory* 34(1). 307–344.
- Sprouse, Jon, Shin Fukuda, Hajime Ono & Robert Kluender. 2011. Reverse island effects and the backward search for a licenser in multiple wh-questions: Reverse island effects in multiple wh-questions. *Syntax* 14(2). 179–203. DOI: 10.1111/j.1467-9612.2011.00153.x.
- Sprouse, Jon, Matt Wagers & Colin Phillips. 2012. A test of the relation between working-memory capacity and syntactic island effects. *Language* 88. 82–123.
- Stalnaker, Robert C. 1978. Assertion. In *Pragmatics*, 315–332. Brill. DOI: 10.1163/9789004368873\_013.
- Staub, Adrian & Keith Rayner. 2007. Eye movements and on-line comprehension processes. In M. Gareth Gaskell (ed.), *The Oxford handbook of psycholinguistics*, 326–342. Oxford, UK & New York: Oxford University Press. DOI: 10.1093/oxfordhb/9780198568971.013.0019.
- Stepanov, Arthur. 2007. The end of CED? Minimalism and extraction domains. *Syntax* 10(1). 80–126.

## References

- Stowe, Laurie A. 1986. Parsing wh-constructions: Evidence for on-line gap location. *Language and Cognitive Processes* 1(3). 227–245. DOI: 10.1080/01690968608407062.
- Svartvik, Jan & Randolph Quirk. 1980. *A corpus of English conversation* (Lund studies in English 56). Lund: C.W.K. Gleerup.
- Szabolcsi, Anna. 2006. Strong versus weak islands. In Martin Everaert & Henk C. van Riemsdijk (eds.), *The Blackwell companion to syntax*, 480–531. Oxford, UK: Blackwell.
- Szabolcsi, Anna & Frans Zwarts. 1990. Semantic properties of composed functions and the distribution of wh-phrases. English (US). In Martin Stokhof & Leen Torenvliet (eds.), *Proceedings of the Seventh Amsterdam Colloquium*, 529–555. Institute for Language, Logic, & Information.
- Takahashi, Daiko. 1994. *Minimality of movement*. Storrs: University of Connecticut. (Ph.D. Thesis).
- Takizala, Alexis. 1973. Focus and relativization: The case of Kihung'an. In John P. Kimball (ed.), *Syntax and semantics*, vol. 2, 123–148. Brill. DOI: 10.1163/9789004368804\_005.
- Tanenhaus, Michael K., James S. Magnuson, Delphine Dahan & Craig Chambers. 2000. Eye movements and lexical access in spoken-language comprehension: Evaluating a linking hypothesis between fixations and linguistic processing. *Journal of Psycholinguistic Research*, 29(6). 557–580. DOI: 10.1023/A:1026464108329.
- Tanenhaus, Michael K., Laurie A. Stowe & Greg N. Carlson. 1985. The interactions of lexical expectation and pragmatics in parsing filler-gap constructions. In *Proceedings of the seventh Annual Cognitive Science Society Meeting*. London: Lawrence Erlbaum Associates.
- Tellier, Christine. 1990. Subjacency and subject condition violations in French. *Linguistic Inquiry* 21(2). 306–311. <http://www.jstor.org/stable/4178676>.
- Tellier, Christine. 1991. *Licensing theory and French parasitic gaps* (Studies in Natural Language and Linguistic Theory 26). Dordrecht: Kluwer.
- Thiberge, Gabriel. 2018. Position du syntagme wh- en français : Réelle optionnalité ou biais sociolinguistique ? *ELIS : Echanges de linguistique en Sorbonne* 5. <https://halshs.archives-ouvertes.fr/halshs-01802590>.
- Tonhauser, Judith & Lisa Matthewson. 2015. Empirical evidence in research on meaning. manuscript. <https://semanticsarchive.net/Archive/TVhYTkOZ/Tonhauser-Matthewson-evidence.pdf> (10 July, 2020).
- Traxler, Matthew J., Robin K. Morris & Rachel E. Seely. 2002. Processing subject and object relative clauses: Evidence from eye movements. *Journal of Memory and Language* 47(1). 69–90. DOI: 10.1006/jmla.2001.2836.

- Traxler, Matthew J. & Martin J. Pickering. 1996. Plausibility and the processing of unbounded dependencies: An eye-tracking study. *Journal of Memory and Language* 35. 454–475.
- Trotta, Joe. 2000. *Wh-clauses in English: Aspects of theory and description* (Language and computers 34). Amsterdam: Rodopi.
- Truswell, Robert. 2011. *Events, phrases and questions*. Oxford, UK & New York: Oxford University Press.
- Tuller, Laurice A. 1986. *Bijjective relations in universal grammar and the syntax of Hausa*. UCLA. (Ph.D. Thesis).
- Ueno, Mieko & Maria Polinsky. 2009. Does headedness affect processing? A new look at the VO–OV contrast. *Journal of Linguistics* 45(3). 675–710. DOI: 10.1017/S0022226709990065.
- Uriagereka, Juan. 2011. *Spell-out and the Minimalist Program*. Oxford: Oxford University Press. DOI: 10.1093/acprof:oso/9780199593521.001.0001.
- Vallduví, Enric. 1992. *The informational component*. New York: Garland.
- Vasishth, Shrvan & Richard L. Lewis. 2006. Argument-head distance and processing complexity: Explaining both locality and antilocality effects. *Language* 82(4). 767–794.
- Wanner, Eric & Michael Maratsos. 1978. An ATN approach to comprehension. In Morris Halle, Joan Bresnan & George A. Miller (eds.), *Linguistic theory and psychological reality*, 119–161. Cambridge, MA: MIT Press.
- Watanabe, Akira. 1992. *Wh-in-situ, subjacency, and chain formation* (MIT Occasional Papers in Linguistics 2). Cambridge, MA: MITWPL.
- Webelhuth, Gert. 2007. Complex topic-comment structures in HPSG. In Stefan Müller (ed.), *Proceedings of the 14th International Conference on Head-Driven Phrase Structure Grammar, Stanford Department of Linguistics and CSLI's LinGO Lab*, 306–322. Stanford, CA: CSLI Publications. DOI: 10.21248/hpsg.2007.18.
- Webelhuth, Gert. 2012. The distribution of that-clauses in English: An SBCG account. In Hans C. Boas & Ivan A. Sag (eds.), *Sign-Based Construction Grammar*, 203–227. Stanford: CSLI Publications.
- Wexler, Kenneth & Peter W. Culicover. 1980. *Formal principles of language acquisition*. Cambridge, MA: MIT Press.
- Wickham, Hadley. 2016. *Ggplot2: Elegant graphics for data analysis*. Cham: Springer. DOI: 10.1007/978-3-319-24277-4. <https://ggplot2.tidyverse.org>.
- Winckel, Elodie & Anne Abeillé. 2020. French subject island constraint? A discourse-based HPSG account. *Linguisticæ Investigationes* 43(1). 94–127.

## References

- Winckel, Elodie, Anne Abeillé, Barbara Hemforth & Edward Gibson. In preparation. *Discourse-based constraints on long-distance dependencies generalize across constructions and languages*.
- Yoshida, Masaya, Nina Kazanina, Leticia Pablos & Patrick Sturt. 2014. On the origin of islands. *Language, Cognition and Neuroscience* 29(7). 761–770. DOI: 10.1080/01690965.2013.788196.
- Zaenen, Annie. 1983. On syntactic binding. *Linguistic Inquiry* 14. 469–504. <https://www.jstor.org/stable/4178340>.

# Name index

- Abeillé, Anne, xvii, 8, 9, 11, 16, 45, 47, 60, 93, 100, 105, 120, 123, 124, 133, 141, 147, 194, 195, 205, 230, 352, 384, 385, 387, 388, 394, 401, 403, 404, 411, 412, 425, 427, 429–431, 434, 437–439, 441, 443, 445, 454, 455, 461, 471, 477, 481, 483
- Adli, Aria, 305, 306, 314
- Aguila-Multner, Gabriel, 401, 404
- Alexiadou, Artemis, 36
- Almeida, Diego, 13, 101
- Ambar, Manuela, 303
- Ambridge, Ben, 87, 90, 394, 483
- An, Aixiu, 478
- Aoun, Joseph, 12
- Ariel, Mira, 76
- Armstrong, Nigel, 156
- ATILF, 124, 195, 265
- Bach, Emmon, 88
- Bader, Markus, 159
- Baroni, Marco, 30
- Barr, Dale J., 149
- Barry, Guy, 421
- Belletti, Adriana, 378
- Bender, Emily M., 422
- Berard, Lolita, 471
- Beysade, Claire, 314
- Bianchi, Valentina, 108, 109, 111, 113
- Bilbiie, Gabriela, 46, 127, 437
- Bildhauer, Felix, 402, 417–422, 457, 458, 477
- Blanche-Benveniste, Claire, 120, 371
- Blaszczak, Joanna, 287
- Bloom, Paul, 74
- Boeckx, Cedric, 42, 314
- Boland, Julie E., 63
- Bolinger, Dwight, 78
- Bonami, Olivier, 10, 401, 402, 411, 454, 455
- Borsley, Robert D., 8, 9, 401, 425, 426, 437
- Bosch, Sina, 372
- Bošković, Željko, 305
- Bouma, Gosse, 63, 421, 425, 427, 428
- Bresnan, Joan, 92, 93, 398, 438, 446
- Brew, Chris, 478
- Bröker, Norbert, 72
- Burzio, Luigi, 37, 381
- Candito, Marie, 70, 100, 120, 123, 124, 133, 352, 361
- Carpenter, Patricia A., 170
- Carroll, John M., 61
- Cattell, Ray, 19
- Chafe, Wallace L., 80
- Chaves, Rui P., 9, 10, 12, 14, 54, 56–60, 63, 77–80, 99, 105, 108, 109, 155, 162, 168, 231, 352, 361, 371, 385, 394, 403, 426, 461, 473

*Name index*

- Cheng, Lisa Lai Shen, 303, 305, 306, 314
- Chesi, Cristiano, 108, 109, 111, 113
- Chomsky, Noam, 12, 13, 15, 19, 23–40, 50, 61, 76, 77, 122, 136, 195, 377, 484
- Christensen, Rune H. B., 149
- Cinque, Guglielmo, 8, 13, 28, 30
- Clark, Herbert H., 73, 74
- Clifton, Charles, 67, 170
- Clopper, C. J., 130
- Comorovski, Ileana, 305
- Comrie, Bernard, 7, 68, 69, 93, 413
- Conklin, Kathryn, 170
- Cook, Philippa, 418–420, 422, 457, 458, 477
- Copestake, Ann, 401, 407, 412, 413, 415, 482
- Corver, Norbert, 41
- Coveney, Aidan B., 306, 314
- Crysmann, Berthold, 394, 401, 404, 425, 426, 437
- Culicover, Peter W., 26, 39, 41, 64
- Cuneo, Nicole, 87, 90
- Dahl, Anne, 105
- Davies, William D., 473
- De Kuthy, Kordula, 402, 417, 418, 420–422
- de Vries, Mark, 10
- Deane, Paul, 34, 89
- Delais-Roussarie, Elisabeth, 402
- Dery, Jeruen E., 57–59, 99, 105, 108, 109, 155, 162, 168, 371
- Destruel, Emilie, 338, 339, 350
- Deulofeu, José, 438
- Dillon, Brian, 147–150, 187, 188, 216, 218, 225, 235, 236, 247, 248, 298, 299, 308–310, 320, 321, 331, 332, 345, 346, 355, 357, 358, 366, 367
- Do, Monica L., 57
- Doetjes, Jenny, 7, 396, 443
- Dong, Zhiyin, 55
- Downing, Bruce, 10
- Dowty, David R., 418
- Drummond, Alex, xvii, 144, 185, 212, 223, 232, 245, 294, 306, 317, 329, 343, 355, 363
- Dubinsky, Stanley, 473
- Duffy, Susan A., 171
- Edwards, Allen L, 156, 306
- Ehrlich, Susan F., 171
- Engdahl, Elisabeth, 402, 417, 418, 421
- Erteschik-Shir, Nomi, 13, 16, 23, 26, 60, 64, 76–78, 81, 86–92, 184, 394, 472
- Espinal, Maria-Teresa, 401
- Fadlon, Julie, 68
- Fedorenko, Evelina, 144
- Fodor, Janet D., 5, 421, 473
- Francom, Jerid Cole, 105
- Frazier, Lyn, 67, 471
- Fukuda, Shin, 107, 109, 115, 118
- Gallego, Ángel J., 25, 42, 55
- Gazdar, Gerald, 63
- Geisler, Christer, 386, 387
- Gennari, Silvia P., 229, 230, 240
- Gibson, Ted, 68, 69, 73, 144, 341
- Ginzburg, Jonathan, 401–403, 405–407, 425, 427, 429, 430, 432, 436, 477
- Giorgi, Alessandra, 383, 384
- Godard, Danièle, 5, 8–10, 16, 19, 34, 35, 45, 47–49, 51–53, 58, 63,

- 99, 120, 121, 133, 140, 141, 211,  
352, 373, 384, 399, 401, 404,  
411, 412, 425, 427, 429, 437–  
439, 441, 453, 477, 481
- Godfrey, John J., 73
- Goldberg, Adele E., 87, 90–92, 184,  
213, 294, 393, 394, 472, 483
- Goodall, Grant, 105
- Götze, Michael, 82, 83
- Greco, Ciro, 111, 113
- Grice, Paul H., 79, 81
- Gries, Stefan Th., 386, 388
- Grosu, Alexander, 78, 352
- Guéron, Jacqueline, 4
- Gundel, Jeanette K., 92
- Gussenhoven, Carlos, 397
- Guzmán Naranjo, Matías, 478
- Haegeman, Liliane, 37, 384, 386
- Hale, John T., 255
- Hartig, Florian, 162
- Häussler, Jana, 159
- Hawkins, John A., 68, 75, 76
- Heaton, Raina, 92
- Heck, Fabian, 20, 53, 121, 122, 134, 135,  
141, 181, 194, 211, 481
- Hemforth, Barbara, 101, 159, 341
- Herschensohn, Julia, 378–380
- Hirschbühler, Paul, 29
- Hoffmann, Thomas, 386, 387
- Hofmeister, Philip, 56, 59, 60, 78
- Holmes, Virginia M., 68
- Horn, George, 23, 88
- Huang, Cheng-Teh J., 12, 13, 15, 30,  
31, 35, 53, 55, 305, 306
- Huddleston, Ronald, 25, 54, 361
- Hudson, Richard A., 70, 72
- Hukari, Thomas E., 428
- Hyams, Nina, 74
- Jackendoff, Ray, 64, 438
- Jacobs, Joachim, 82
- Jiménez-Fernández, Angel, 25, 55, 57,  
76, 77
- Johansson, Christine, 386, 387
- Jurka, Johannes, 24, 106, 109–111, 113,  
115, 117, 272, 383
- Just, Marcel A., 170, 254
- Kaan, Edith, 67
- Kaiser, Elsi, 57
- Kaiser, Georg, 303
- Karsenberg, Lena, 7, 443
- Kasper, Walter, 478
- Kayne, Richard S., 10, 31, 35, 36, 40,  
54, 380, 381, 483
- Keenan, Edward L., 68, 69, 93, 413
- Keller, Frank, 61, 144
- Kemper, Susan, 74
- Keshev, Maayan, 181, 262
- Kim, Jong-Bok, 401, 429
- Kiss, Tibor, 438
- Kitagawa, Yoshi, 36
- Kluender, Robert, 13, 16, 26, 29, 56,  
65, 72–77, 96, 99–101, 184,  
251, 255, 282, 294, 352, 372,  
376, 394, 471
- Kobzeva, Anastasia, 112, 113, 115, 116
- Koenig, Jean-Pierre, 401
- Kolliakou, Dimitra, 453
- König, Esther, 124
- Koopman, Hilda, 10, 36, 439
- Kratzer, Angelika, 36
- Krifka, Manfred, 80–85, 419
- Kuno, Susumu, 25, 79, 80, 88, 89, 91,  
92, 394, 422, 438, 483
- Kuroda, Sige-Yuki, 82
- Kush, Dave, 105, 111–113, 115, 116
- Kutas, Marta, 29, 65, 77, 101

*Name index*

- Kuteva, Tania, 7  
Kynette, Donna, 74
- Labelle, Marie, 487  
Ladusaw, William A., 82  
Lahousse, Karen, 7, 121, 377, 392, 431, 443  
Lakoff, George, 61  
Lambrecht, Knud, 7, 86, 87, 91, 92, 337, 396  
Landau, Idan, 378, 379, 381, 382  
Lappin, Shalom, 394  
Larrivée, Pierre, 315  
Lascarides, Alex, 407  
Lasnik, Howard, 55  
Laurens, Frédéric, 46, 127, 437  
Le Goffic, Pierre, 47  
Lee, Seung Han, 471, 472  
Legendre, Géraldine, 378, 379, 381, 382, 487  
Levine, Robert D., 63, 428  
Lewis, Richard L., 59, 68  
Lezius, Wolfgang, 124  
Li, Yen-hui Audrey, 12  
Liu, Haitao, 70, 71  
Liu, Yingtong, 14, 483  
Longobardi, Giuseppe, 19, 36, 383, 384  
Lu, Jiayi, 12
- Machicao y Priemer, Antonio, 411, 453  
Marandin, Jean-Marie, 8, 9, 84, 401, 433  
Maratsos, Michael, 65, 68, 101  
Matthewson, Lisa, 144  
McDonald, Maryellen C., 229, 230, 240
- Mchombo, Sam A., 92, 93, 398, 438, 446  
Melis, Ludo, 439  
Meltzer-Asscher, Aya, 181, 262  
Mensching, Guido, 8, 453  
Miles, Walter R., 174  
Miller, Philip, 401, 404, 471  
Milner, Jean Claude, 454  
Momma, Shota, 65–67, 181  
Moshier, Andrew M., 426  
Müller, Gereon, 41–44  
Müller, Stefan, 401, 412, 419–422, 457, 478
- Norman, Suzanne, 74  
Nunes, Jairo, 38
- O'Reagan, J. Kevin, 68  
Obenauer, Hans-Georg, 8  
Osborne, Timothy, 70, 72
- Pañeda, Claudia, 112, 113  
Pearson, E. S., 130  
Pechmann, Thomas, 144  
Perlmutter, David M., 37  
Pesetsky, David, 10, 77, 78, 439  
Phillips, Colin, 65, 66, 106, 109  
Pickering, Martin J., 63, 421  
Pizarro-Guevara, Jed Sam, 92  
Polinsky, Maria, 37, 38, 74, 108, 109, 111, 113, 377  
Pollard, Carl J., 63, 401, 403, 413, 426, 427, 450  
Portner, Paul, 395  
Pozniak, Céline, 101, 341  
Prince, Ellen, 338, 397–399  
Przepiórkowski, Adam, 427  
Pullum, Geoffrey, 25, 54, 361



- Putnam, Michael T., 9, 10, 12, 14, 56,  
58, 63, 79, 80, 105, 108, 109,  
352, 371, 385, 394, 426
- Quaglia, Stefano, 303
- Quirk, Randolph, 73
- R Core Team, 102, 129, 162, 175, 176,  
203, 257, 308, 495
- Radford, Andrew, 76
- Rayner, Keith, 168, 170, 171
- Reinhart, Tanya, 81, 82, 305, 314
- Richter, Frank, 417, 419
- Riou, Etienne, 159
- Rizzi, Luigi, 13, 54, 55, 68, 378
- Robin, Xavier, 149, 150
- Rooryck, Johan, 303, 305, 314
- Rooth, Mats, 82
- Ross, Haj, 13
- Ross, John Robert, 3, 12–14, 19–23,  
28, 30, 35, 41, 44, 53, 72, 77,  
115, 351, 391, 393, 483
- Sag, Ivan A., 5, 9, 48, 56, 59, 60, 63,  
401–407, 413, 421, 425–427,  
429, 430, 432, 436, 437, 450,  
453, 477
- Saito, Mamoru, 55
- Santorini, Beatrice, 54
- Schachter, Paul, 92
- Schlonsky, Ur, 303
- Schlueter, Zoe, 65
- Schneider, Walter, 160
- Schütze, Carson T., 60, 62, 144, 145
- Seddah, Djamé, 70, 100, 120, 123, 124,  
133, 352, 361
- Simonenko, Alexandra, 57, 77, 374,  
375
- Song, Sanghoun, 123, 392, 397, 400,  
401, 403, 412, 415, 419–423,  
425, 438, 449, 451, 457, 458,  
466, 477, 482, 503
- Sorace, Antonella, 144, 487
- Sportiche, Dominique, 10, 36, 439,  
453
- Sprouse, Jon, 14, 15, 57, 60, 62, 101,  
102, 105–109, 111, 113–117,  
181, 182, 262, 326, 385, 388,  
395, 396
- Stalnaker, Robert C., 80
- Staub, Adrian, 170
- Stepanov, Arthur, 19, 26, 34, 42, 53–  
55, 194, 211, 483
- Stowe, Laurie A., 66, 99
- Svartvik, Jan, 73
- Szabolcsi, Anna, 13, 30
- Takahashi, Daiko, 43
- Takizala, Alexis, 92
- Tanenhaus, Michael K., 99, 421
- Tellier, Christine, 20, 47, 49–53, 57,  
95, 99, 122, 124, 141, 194, 201,  
209, 211, 222, 481, 484
- Thiberge, Gabriel, 306, 311
- Tonhauser, Judith, 144
- Traxler, Matthew J., 63, 101
- Trotta, Joe, 386, 387
- Truswell, Robert, 54
- Tuller, Laurice A., 394
- Ueno, Mieko, 74
- Uriagereka, Juan, 16, 25, 26, 38–40,  
42–44, 55, 61, 195, 272, 383,  
384
- Vallduví, Enric, 402, 417, 418, 421
- Valois, Daniel, 29
- Vasishth, Shravan, 59, 68

*Name index*

Wagers, Matthew, 92, 147–150, 187,  
188, 216, 218, 225, 235, 236,  
247, 248, 298, 299, 308–310,  
320, 321, 331, 332, 345, 346,  
355, 357, 358, 366, 367

Wanner, Eric, 65, 68, 101

Wasow, Thomas, 73, 74

Watanabe, Akira, 305

Webelhuth, Gert, 394, 419, 422, 450,  
457, 477

Wexler, Kenneth, 26, 39, 41, 74

Wickham, Hadley, 103, 149

Winckel, Elodie, 100, 105, 120, 124,  
147, 194, 195, 205, 230, 400,  
404, 411, 425, 429, 434, 443,  
445, 453, 477

Yabushita, Katsuhiko, 395

Yoshida, Masaya, 172, 173, 255

Zaenen, Annie, 428

Zwarts, Frans, 13



# French subject islands

This book examines extractions out of the subject, which is traditionally considered to be an island for extraction. There is a debate among linguists regarding whether the “subject island constraint” is a syntactic phenomenon or an illusion caused by cognitive or pragmatic factors. The book focusses on French, that provides an interesting case study because it allows certain extractions out of the subject despite not being a typical null-subject language. The book takes a discourse-based approach and introduces the “Focus-Background Conflict” constraint, which posits that a focused element cannot be part of a backgrounded constituent due to a pragmatic contradiction. The major novelty of this proposal is that it predicts a distinction between extractions out of the subject in focalizing and non-focalizing constructions.

The central contribution of this book is to offer the detailed results of a series of empirical studies (corpus studies and experiments) on extractions out of the subject in French. These studies offer evidence for the possibility of extraction out of the subject in French. But they also reveal a clear distinction between constructions. While extractions out of the subject are common and highly acceptable in relative clauses, this is not the case for interrogatives and clefts.

Finally, the book proposes a Head-Driven Phrase Structure Grammar (HPSG) analysis of subject islands. It demonstrates the interaction between information structure and syntax using a representation of information structure based on Minimal Recursion Semantics (MRS).