

II. Materials and Methods

II.1 Materials

II.1.1 Chemicals and reagents

Ampicillin	Sigma-Aldrich Co., St. Louis, MO
Aprotinin	Roche Diagnostics Corp., Indianapolis, IN
Benzamidine	Sigma-Aldrich Co., St. Louis, MO
Bestatin	Roche Diagnostics Corp., Indianapolis, IN
β -mercaptoethanol (β -ME)	Sigma-Aldrich Co., St. Louis, MO
Calcium chloride (CaCl_2)	Sigma-Aldrich Co., St. Louis, MO
Chymostatin	Roche Diagnostics Corp., Indianapolis, IN
Complete protease inhibitor cocktail	Roche Diagnostics Corp., Indianapolis, IN
Ethanol	Aaper Alcohol and Chemical Co, Shelbyville, KY
Ethylenediaminetetraacetic acid (EDTA)	Roche Diagnostics Corp., Indianapolis, IN
Glycine	Sigma-Aldrich Co., St. Louis, MO
Heparin (Sodium)	USB Corp., Cleveland, OH
Human plasma	Sigma-Aldrich Co., St. Louis, MO
Imidazole	Sigma-Aldrich Co., St. Louis, MO
Isopropanol	J.T. Baker, Phillipsburg, NJ
Leupeptin	Roche Diagnostics Corp., Indianapolis, IN
Methanol	J.T. Baker, Phillipsburg, NJ
Mineral oil	Sigma-Aldrich Co., St. Louis, MO
NP-40 (detergent)	Sigma-Aldrich Co., St. Louis, MO
Pepstatin	Roche Diagnostics Corp., Indianapolis, IN
Phenyl methyl sulfonyl fluoride (PMSF)	Bachem Bioscience Inc., King of Prussia, PA

Phosphoramidon	Roche Diagnostics Corp., Indianapolis, IN
Tween20 (detergent)	Sigma-Aldrich Co., St. Louis, MO
Potassium chloride (KCl)	Sigma-Aldrich Co., St. Louis, MO
Potassium phosphate (K ₂ PO ₄)	Sigma-Aldrich Co., St. Louis, MO
Sodium chloride (NaCl)	Sigma-Aldrich Co., St. Louis, MO
Soybean trypsin inhibitor	Sigma-Aldrich Co., St. Louis, MO
Tosyl-Lys-chloromethylketone (TLCK)	Bachem Bioscience Inc., King of Prussia, PA
Tosyl-Phe-chloromethylketone (TPCK)	Bachem Bioscience Inc., King of Prussia, PA
Tris-HCl, pH 7.5 (1 M)	TEKnova Inc., Half Moon Bay, CA
Triton-X 100	Sigma-Aldrich Co., St. Louis, MO

II.1.2 Molecular biology

<i>Apal</i>	New England Biolabs Inc., Beverly, MA
BlueJuice™ loading buffer (10x)	Invitrogen Corp., Carlsbad, CA
Bovine serum albumin (BSA), (10 mg/mL)	New England Biolabs Inc., Beverly, MA
Deoxyribonucleoside triphosphate (dNTP) mix	New England Biolabs Inc., Beverly, MA
<i>EcoRI</i>	New England Biolabs Inc., Beverly, MA
<i>EcoRI</i> buffer	New England Biolabs Inc., Beverly, MA
Ethidium bromide (EtBr)	American Bioanalytical, Natick, MA
Hofer™ HE 3 mini horizontal submarine unit	Amersham Biosciences Corp., Piscataway, NJ
imMedia™ Amp agar	Invitrogen Corp., Carlsbad, CA
1-kb DNA ladder	New England Biolabs Inc., Beverly, MA
Miller's Luria-Bertani (LB) medium	Mediatech, Inc., Herndon, VA
MinElute Gel Extraction Kit	Qiagen, Valencia, CA
NEBuffer 2 and 4	New England Biolabs Inc., Beverly, MA
<i>Pyrococcus furiosus</i> (<i>Pfu</i>) DNA polymerase	New England Biolabs Inc., Beverly, MA

QIAfilter Plasmid Maxi Kit	Qiagen, Valencia, CA
QIAprep Spin Miniprep Kit	Qiagen, Valencia, CA
QIAquick PCR purification kit	Qiagen, Valencia, CA
QuikChange II Mutagenesis Kit XL	Stratagene, LaJolla, CA
Razor blades	VWR International, West Chester, PA
SeaKem Gold agarose precast gels (1 %), 1x Tris-Acetate-EDTA(TAE) + EtBr	Cambrex Bio Science Rockland, Inc., Rockland, ME
Seakem® LE agarose	BMA products, Rockland, ME
<i>Thermus aquaticus</i> (<i>Taq</i>) DNA polymerase	New England Biolabs Inc., Beverly, MA
T4 DNA ligase	New England Biolabs Inc., Beverly, MA
TAE buffer (10x)	Mediatech, Inc., Herndon, VA
Vector pcDNA4/HisMaxC	Invitrogen Corp., Carlsbad, CA
Vector pSecTag/FRT/V5-His-TOPO	Invitrogen Corp., Carlsbad, CA
<i>Xba</i> I	New England Biolabs Inc., Beverly, MA
<i>Xho</i> I	New England Biolabs Inc., Beverly, MA

II.1.3 Cell culture

Baby hamster kidney (BHK) cells	American Type Culture Collection
Bovine serum albumin	New England Biolabs Inc., Beverly, MA
Cell culture disks, 100 x 20 mm	Corning Inc., Corning, NY
Cell culture flasks (25, 75, 162, 225 cm ²)	Corning Inc., Corning, NY
Cell culture plates (96-, 24-, 12-, 6-well)	Corning Inc., Corning, NY
Cell scraper	Sarstedt Inc., Newton, CA
Centrifuge tubes, 15 or 50 mL	Corning Inc., Corning, NY
Cloning disks	Belart Products, Pequannock, NJ
Culture tubes, 17 x 100 mm	VWR International, West Chester, PA
Fetal bovine serum	SeraCare Life Sciences, Inc., Oceanside, CA
G418	Invitrogen Corp., Carlsbad, CA
HEK 293 cells	American Type Culture Collection

Lipofectamine 2000 reagent	Invitrogen Corp., Carlsbad, CA
Modified Eagle's medium (MEM)- α	Invitrogen Corp., Carlsbad, CA
OPTI- MEM I	Invitrogen Corp., Carlsbad, CA
Phosphate-buffered saline (PBS), 1x	Invitrogen Corp., Carlsbad, CA
Trypsin (0.05 %)-EDTA (0.53 mM) solution	Invitrogen Corp., Carlsbad, CA
Syringes, 1 mL	BD and Co., Franklin Lakes, NJ

II.1.4 Proteases and chromogenic substrates

Elastase, human neutrophil	EMD Biosciences, Inc., La Jolla, CA
Enterokinase, light chain, bovine, recombinant	Novagen Inc., Madison, WI
Factor Xa, bovine plasma	Chromogenix, Milano, Italy
Kallikrein, human plasma	EMD Biosciences, Inc., La Jolla, CA
Plasmin, human	Chromogenix, Milano, Italy
Thrombin, human	USB Corp., Cleveland, OH
Trypsin, bovine pancreas	Sigma-Aldrich Co., St. Louis, MO

A description of the following chromogenic substrates can be found on page 68, Table 2.1:

S-2222, S-2238, S-2251, S-2266, S-2288, S-2302, S-2366, S-2403 2444, S-2484, S-2765	Chromogenix, Milano, Italy Distributor: DiaPharma Group, Inc., West Chester, OH
L-1220, L-1240, L-1242, L-1250, L-1285, L-1300, L-1635, L-1720, L-1725, L-1990	Bachem Bioscience, Inc., King of Prussia, PA

II.1.5 Protein chemistry

cGMP Direct Biotrak enzyme immunoassay (EIA) kit	Amersham Biosciences Corp., Piscataway, NJ
Coomassie Brilliant blue R-250	Pierce Biotechnology Inc., Rockford, IL
Enhanced chemiluminescent (ECL) TM protein biotinylation module	Amersham Biosciences Corp., Piscataway, NJ
ECL TM Western blotting reagent	Amersham Biosciences Corp., Piscataway, NJ
EKapture beads	Novagen Inc., Madison, WI
Hypercassette TM , 18 x 24 cm	Amersham Biosciences Corp., Piscataway, NJ
Hyperfilm TM ECL, 5 x 7 inches	Amersham Biosciences Corp., Piscataway, NJ
Ni-NTA XK26 Superflow column	Qiagen, Valencia, CA
Nitrocellulose membranes, 0.45 μ m	Invitrogen Corp., Carlsbad, CA
PAGEr [®] Gold precast gel, 10 or 15 %	Cambrex Bio Science Rockland, Inc., Rockland, ME
PBS, 10x	Mediatech, Inc., Herndon, VA
SeeBluePlus2 protein standard	Invitrogen Corp., Carlsbad, CA
SilverXpress [®] silver staining kit	Invitrogen Corp., Carlsbad, CA
Tricine SDS running buffer	Invitrogen Corp., Carlsbad, CA
Tricine SDS sample buffer	Invitrogen Corp., Carlsbad, CA
Mouse monoclonal antibodies:	
Anti-V5 antibody (1.0 mg/mL)	Invitrogen Corp., Carlsbad, CA
Anti-V5-horse radish peroxidase (HRP) antibody (1.2 mg/mL)	Invitrogen Corp., Carlsbad, CA
Anti-Xpress TM -HRP antibody (2.0 mg/mL)	Invitrogen Corp., Carlsbad, CA

II.1.6 Instruments and accessories

Cell culture incubator	Fisher Scientific Co., Pittsburgh, PA
ChemiImager™Ready	Alpha Innotech Corp., San Leandro, CA
DNA Thermal Cycler	Perkin Elmer, Wellesley, MA
Eppendorf centrifuge 5417R, refrigerated	Brinkmann Instruments, Inc., Westbury, NY
Eppendorf tabletop centrifuge 5415C	Brinkmann Instruments, Inc., Westbury, NY
Hitachi Interface D-7000 apparatus	Hitachi High Technologies America, Inc., San Jose, CA
HP 241 Protein Sequencer	Hewlett-Packard Company, Palo Alto, CA
HP Sample Prep Stadion G1001A	Hewlett-Packard Company, Palo Alto, CA
Incubator shaker innova 4430	New Brunswick Scientific, Edison, NJ
Konica Minolta SRX-101A (X-ray film processor)	Konica Minolta Medical Imaging USA, Inc., Wayne, NJ
Nikon TMS microscope	Nikon Instruments, Inc., Melville, NJ
PowerPac300 power supply	BioRAD Laboratories, Hercules, CA
Rotator Labquake Shaker	Labindustries, Inc., Berkeley, CA
Sequencing column, biphasic	Agilent Technologies, Inc., Palo Alto, CA
Sorvall®GS-3 rotor	GMI, Inc. Albertville, MN
Sorvall®RC 5C superspeed centrifuge	GMI, Inc. Albertville, MN
Sorvall®SS-34 rotor	GMI, Inc. Albertville, MN
Spectra MAX 250 plate reader	Molecular Devices Corp., Sunnyvale, CA
TSK gel®G2000SW beads	Tosoh Corp., Tokyo, Japan
Ultraspec™ 3100 <i>pro</i> UV/visible spectrophotometer	Amersham Biosciences Corp., Piscataway, NJ
VWR digital heatblock	VWR International, West Chester, PA
Water bath Isotherm 210	Fisher Scientific Co., Pittsburgh, PA
Xcell II SureLock™ mini-cell (electrophoresis unit)	Invitrogen Corp., Carlsbad, CA
XCell II™ Western blot module	Invitrogen Corp., Carlsbad, CA

II.1.7 Buffers and solutions

- Activation (and assay) buffer: 100 mM Tris-HCl, pH 7.5,
10 mM CaCl₂

- Cell lysis buffer:
(general) 100 mM Tris-HCl, pH 7.5,
1 % Triton X-100

- Cell lysis buffer:
(cell surface protein detection) 250 mM NaCl
25 mM Tris-HCl, pH 7.5
5 mM EDTA
0.5 % NP-40
One tablet of complete protease inhibitor
cocktail was added to 15 mL of lysis buffer
right before usage.

- Coomassie blue staining solution: 0.1 % Coomassie Brilliant blue
30 % Methanol
10 % Acetic acid

- Western blotting transfer buffer: For 2 L:
80 mL Transfer buffer (25x)
200 mL Methanol
1720 mL H₂O

II.2 Design and Biochemical Characterization of Soluble Corin

III.2.1 Overview of the experimental approach

III.2.1.1 Considering specific features of corin

To study the biochemical properties and activities of corin, we first focused on generating a corin protein that is soluble and can be purified. To do this, two characteristics of corin needed to be considered:

- (a) Topologically, corin belongs to the family of TTSPs. Membrane association of proteins, however, typically complicates protein purification.
- (b) Corin is most likely synthesized as an inactive zymogen that is predicted to require activation cleavage at Arg801. In cell-based assays that were used previously for the initial characterization of corin, corin appeared to get activated by an unknown, inefficient mechanism, most likely mediated by non-specific proteases in cell culture. In such a cell-based system, however, the portion of activated corin remained at a very low level, which was often below the detection by Western analysis. To date, the physiological corin activator, most likely another trypsin-like serine protease, has not been identified.

III.2.1.2 Analyzing cell-membrane association and activation cleavage of corin

To address these two issues, the following steps were taken:

- (a) In other TTSPs such as hepsin, EK, and matriptase, the transmembrane domain is not necessary for their enzymatic activities. To determine if corin requires its transmembrane domain for its biological activity, we first designed a soluble corin protein,

WTsolCorin, lacking the cytoplasmic tail and the transmembrane domain (amino acids 1-124). We would express and characterize the soluble corin.

- (b) In an initial experiment we wanted to determine if the activation cleavage site is indeed located at Arg801, as predicted by the protein sequence and if the activation cleavage at this site is required for the activity of corin in pro-ANP processing. So we generated the corin point mutant R801A and tested it in functional assays. If the point mutation prevents the conversion of zymogen corin to an active protease, mutant R801A is expected to be inactive in functional pro-ANP processing assays.

III.2.1.3 Designing a soluble and activatable recombinant corin for biochemical studies

Using the information that was gained from the initial experiments described in section II.2.1.2 we could now design a recombinant soluble corin that could be purified, activated, and used for biochemical investigations such as substrate specificity and inhibitor studies.

- (a) The transmembrane domain was found unnecessary for the functional activity of corin. We showed that soluble corin had a similar activity as WT corin in processing pro-ANP. Thus, we were able to use a soluble form of corin for the biochemical characterization of the enzyme.
- (b) To produce a soluble corin with an efficient and specific activation cleavage site, we generated EKsolCorin in which the corin activation site RMNKR at residues 797-801 is replaced with the EK cleavage site DDDDK. This substitution allows us to use EK to convert zymogen corin into an active enzyme in a controlled manner.

III.2.1.4 Comparative studies of two soluble forms of corin

Once protocols for the biochemical analysis of EKsolCorin were established, we wanted to address the question whether the extracellular propeptide is required for the biological activity of corin. This led to the generation of a soluble version of corin containing only the protease domain, EKshortCorin. We then studied both forms of soluble corin in functional assays.

II.2.2 Construction of expression plasmids encoding soluble forms of corin

Soluble corin proteins were designed to study the requirement of the transmembrane domain (WTsolCorin), enzyme kinetics and substrate specificity of corin (EKsolCorin), and the requirement of the propeptide of corin for its pro-ANP processing activity (EKshortCorin) (Fig. 2.1). First, expression plasmids encoding WTsolCorin, EKsolCorin and EKshortCorin were generated.

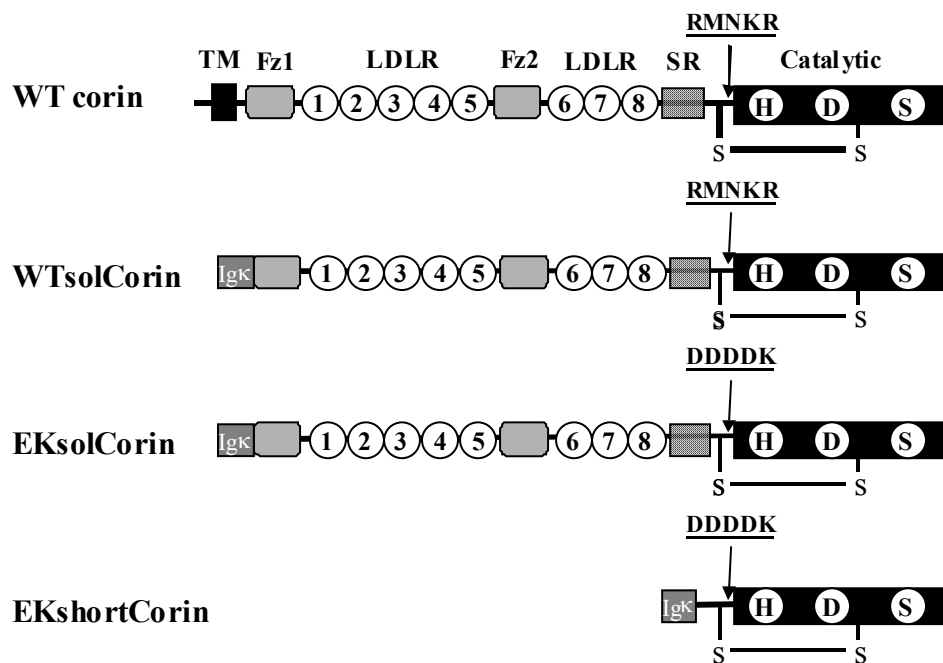

Figure 2.1. Schematic presentation of WT corin and soluble corin proteins. The transmembrane domain (*TM*), Fz cysteine-rich domains (*Fz*), LDLR repeats (*LDLR*), SR cysteine-rich domain (*SR*), and protease catalytic domain (*Catalytic*) with active-site residues histidine (*H*), aspartate (*D*) and serine (*S*) are indicated. The conserved activation cleavage site is indicated by an arrow. The disulfide bond (*S-S*) that connects two polypeptide chains after the activation cleavage is also shown. WT corin, wild-type corin; WTsolCorin, a soluble corin that consists of a signal peptide sequence derived from human Igk chain followed by the extracellular domains of corin; EKsolCorin, a soluble corin that contains all extracellular domains. EKshortCorin, a soluble corin that contains only the protease domain. In EKsolCorin and EKshortCorin, the cytoplasmic tail and transmembrane domain are replaced by a signal peptide from human Igk chain, and an EK recognition sequence (*DDDDK*) is included at the activation cleavage site.

II.2.2.1 Generating plasmid pSECsolCorin encoding WTsolCorin protein

To construct a plasmid expressing a soluble corin, a cDNA fragment containing nucleotides 463–3219 of human corin cDNA (Yan *et al.*, 1999) was amplified by PCR and inserted into the expression vector pSec/FRT/V5-His-TOPO to yield the plasmid pSECsolCorin. This plasmid encodes a protein, WTsolCorin, consisting of an Igκ signal peptide at the N-terminus followed by the amino acid sequence from most of the extracellular region of corin (residues 124-1042), and a viral V5 and a 6xHis tag at the C-terminus. Figure 2.2 shows the expression vector. The steps of the vector construction are described below.

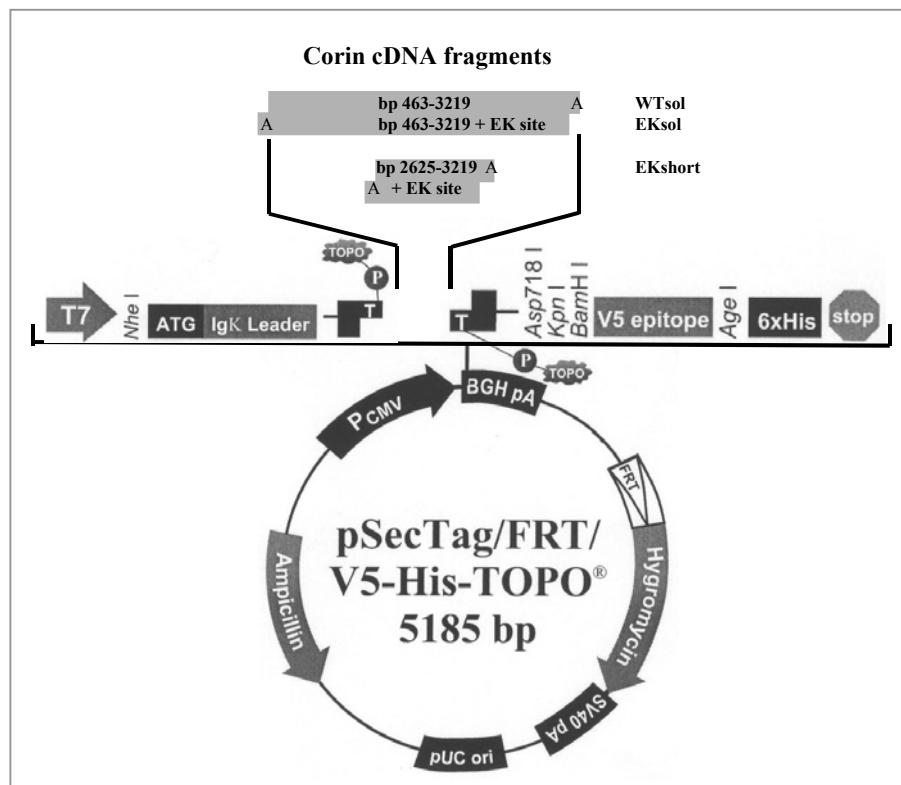

Figure 2.2. Plasmids for the expression of recombinant soluble forms of corin in HEK 293 cells. Schematic representation of the plasmid vector pSecTag/FRT/V5-His-TOPO for the expression of soluble corin proteins WTsolCorin, EKsolCorin, and EKshortCorin. The recombinant proteins expressed by this vector contain an Igκ leader sequence at the N-terminus, and a viral V5 and a 6xHis tag at the C-terminus.

(a) PCR amplification of corin cDNA bp 463-3219

The human corin cDNA sequence from bp 463-3219 was amplified by PCR using the plasmid pcDNACorinV5 (Yan *et al.*, 2000) as template, forward primer 3'-GAT GCT TCT CTC CCA GGG GAC CAA AG-5', backward primer 3'-GTT TAG GAG AAA GGT CTG GAT GTA AAT CTG-5', and the high fidelity *Pfu* DNA polymerase.

The following reagents were included for the PCR experiment:

The PCR cycle program was as followed:

Reagent	Volume
PCR buffer	5 μ L
DNA template (50 ng/ μ L)	2 μ L
dNTP mix (10 mM)	4 μ L
Forward Primer (25 μ M)	2 μ L
Reverse Primer (25 μ M)	2 μ L
H ₂ O	34 μ L
<i>Pfu</i> DNA polymerase (2.5 units/ μ L)	1 μ L
Total:	50 μL

Cycles		T in $^{\circ}$ C	Duration per cycle
PCR step	No of. cycles		
Denaturation	1	95	2 min
Denaturation	30	95	30 s
Annealing		58	1 min
Extension		72	2.5 min
Final Extension	1	72	10 min

The PCR resulted in an amplification product with the expected size of ~2.7 kb, as determined by electrophoresis on an agarose gel (Fig. 2.3A).

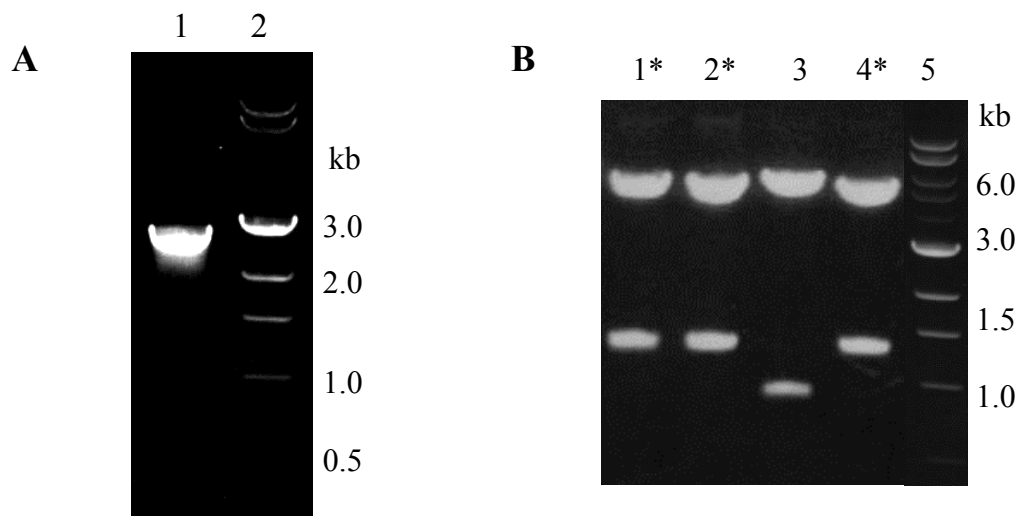

Figure 2.3. Construction of expression plasmid pSECsolCorin. To construct a plasmid expressing the soluble corin WTsolCorin, a cDNA fragment containing nucleotides 463–3219 of human corin cDNA was amplified by PCR and inserted into the expression vector pSec/FRT/V5-His-TOPO to yield the plasmid pSECsolCorin. **(A)** Amplification of bp 463-3219 by PCR resulted in a DNA fragment of ~2.7 kb in length (*lane 1*), as estimated by agarose gel electrophoresis with a 1-kb DNA ladder as size standard (*lane 2*). **(B)** The DNA fragment was inserted into the expression vector using the TOPO cloning method. The right orientation of the insert within the vector was determined by restriction digestion with *XbaI*, followed by agarose gel electrophoresis analysis. Results of four *XbaI*-digested plasmids are shown in lanes 1-4. Positive clones are marked with *. As size standard a 1-kb DNA ladder was used (*lane 5*).

(b) Producing adenine overhangs for TOPO cloning

The TOPO cloning method, which is explained on the following page, requires PCR products that contain 3'-adenine overhangs for efficient insertion. DNA polymerases like *Taq* polymerase produce such amplification products but usually work with lower fidelity than the *Pfu* polymerase, which was used for the PCR experiment in section (a). To combine the high fidelity performance of *Pfu* with the ability of *Taq* to produce 3'-adenine overhangs, the *Pfu* PCR product was treated with *Taq* polymerase after completion of the thermal PCR cycles. To do that, 1 μ L *Taq* DNA polymerase (2 units) was added to the PCR and incubated at 72 °C for 10 min.

(c) Purification of the PCR product

To facilitate the insertion of the *Taq*-treated PCR product into the expression vector, the PCR mixture was first subjected to agarose gel electrophoresis. Ten μL BlueJuice loading buffer was added to 50 μL PCR mixture. Then the entire volume (60 μL) was loaded onto a 1 % TAE agarose gel. The sample was separated in the electric field at 80 Volts for 1 h. Afterwards, the $\sim 2.7\text{-kb}$ band was visualized under ultraviolet (UV) light and carefully cut out with a razor blade. The DNA was extracted from the gel slice using the QiaQuick gel extraction kit from Qiagen according to the manufacturer's manual. In the last step, the purified DNA was eluted from the spin columns (included in the Qiagen kit) with 30 μL H_2O . The DNA fragment was ready for the cloning step.

(d) TOPO TA cloning of PCR product into expression vector pSecTag/FRT/V5-His-TOPO

TOPO cloning is a technology based on the enzyme DNA topoisomerase I, which functions both as a restriction enzyme and a ligase. Its biological role is to cleave and rejoin DNA during replication. The manufacturer of the pSecTag/FRT/V5-His-TOPO expression vector uses the ligase function of the enzyme and provides a linearized vector with *Vaccinia* virus-derived topoisomerase I covalently bound to its specific phosphorylated recognition site.

For the TOPO cloning reaction, 2 μL purified PCR product, 1 μL pSecTag/FRT/V5-His-TOPO vector, 1 μL salt solution provided by the manufacturer, and 1 μL H_2O were added into a tube, gently mixed, and incubated at room temperature for 15 min.

(e) Transformation into OneShot TOP10 cells

Top10 bacteria are an *Escherichia coli* (*E. coli*) strain with a genotype similar to the commonly used DH10B™ strain. One specific genotypical feature of TOP10, is a *hsd* mutation in the methylation and restriction system, which allows *E. coli* to recognize DNA as foreign (Grant *et al.*, 1990). The *hsd* genotype enables transformation of PCR-generated DNA with an efficiency of 1×10^9 colony forming units/ μg supercoiled DNA.

To select and amplify vector clones that incorporated the WTsolCorin insert, one vial of competent OneShot TOP10 cells (~50 μL) was prepared for transformation by gently thawing on ice for 15 min. Then 2 μL of the TOPO cloning reaction mixture was added to the bacteria and incubated on ice for 30 min, allowing the DNA to bind to the exterior of the cells. After heat shock treatment for 30 s in a 42 °C water bath, the cells were immediately put back on ice for 5 min. This step causes the bacterial cells to uptake the foreign plasmid and with it the genetic information for ampicillin resistance, which is later used to select WTsolCorin clones. To allow the transformed cells to express the newly acquired genetic information, 250 μL SOC medium was added to the vial and the cells incubated in a rotating motion (250 rpm) at 37 °C for 1 h. The entire volume was then divided onto two ampicillin containing agar plates. The liquid was evenly spread, and the plates were incubated at 37 °C overnight.

(f) Plasmid amplification and restriction digest with *XbaI*

Samples of 8 bacterial colonies from the experiment described in section (e) were each inoculated in 1.5 mL LB medium containing ampicillin (100 $\mu\text{g}/\text{mL}$). The bacterial cultures were grown for 16 h at 37 °C in a vigorously shaking (250 rpm) incubator. Plasmids were isolated using a QIAprep Spin Miniprep plasmid purification kit (Qiagen) according to the manufacturer's manual. To identify plasmids that incorporated the corin insert in the right

orientation, ~1 µg of plasmid samples was digested with 20 units of the restriction enzyme *XbaI* in NEBuffer 2 and BSA (100 µg/mL) for 1 h at 37 °C. *XbaI* restriction sites are located at bp 1679 of the vector sequence and at bp 2561 of the corin insert. Restriction digestion of plasmids containing the insert in the right orientation is expected to result in two DNA fragments of ~6.5 and ~1.2 kb, respectively. The digested plasmid samples were analyzed by agarose gel electrophoresis using a 1-kb DNA ladder as size standard (Fig 2.3B). Bacterial colonies containing the plasmid with correctly oriented inserts were each inoculated in 250 mL LB medium containing ampicillin (100 µg/mL) and were grown as described above. Plasmids were purified using a QIAfilter Plasmid Maxi kit (Qiagen) following the manufacturer instructions and the plasmid preparations stored at – 20 °C. The sequence of the corin insert was confirmed by direct DNA sequencing.

II.2.2.2 Generating plasmids pSECEKsolCorin and pSECEKshortCorin encoding EKsolCorin and EKshortCorin proteins

To enable proteolytic activation of WTsolCorin, the conserved corin activation site at residue Arg801 was replaced by an EK cleavage site. EK is the physiological activator of trypsinogen and cleaves trypsinogen at the sequence (Asp)₄-Lys (Anderson *et al.*, 1977). The enzyme is highly specific and tolerates very few changes to its recognition site (Light and Janska, 1989; Maroux *et al.*, 1971). This makes EK an ideal choice for zymogen activation of proteases with unknown activators. EK is also widely used to digest fusion proteins to release the fusion tag from recombinant proteins.

To construct a plasmid encoding a soluble corin that can be activated by EK, PCR-based mutagenesis was performed using the QuikChange II Site-Directed Mutagenesis Kit II XL from Stratagene, with plasmid pSECsolCorin (see section II.2.2.1) as a template. Nucleotides 2482–2496 (CGA ATG AAC AAA AGG) of human corin cDNA were replaced by nucleotides GAC GAT GAC GAT AAG. The resulting plasmid, pSECEKsolCorin, encodes a soluble corin, EKsolCorin, with the amino acid sequence DDDDK replacing the original sequence RMNKR at the conserved activation cleavage site. The protein expressed

by pSECEKshortCorin contains an Ig κ signal peptide at the N-terminus, and a viral V5 tag and a 6xHis tag at the C-terminus.

Subsequently, the plasmid pSECEKsolCorin was used as a PCR template to generate the expression vector pSECEKshortCorin, encoding a protein that consists of only the catalytic domain of human corin (amino acids 787-1042). Oligonucleotide primers 5'-GTT TAG GAG AAA GGT CTG GAT GTA AAT CTG-3' and 5'-AAA CAA GAC TGT GGG CGC CG-3' and *Pfu* polymerase were used for the PCR amplification of nucleotides 2452-3219 of human corin cDNA. The PCR was performed as described in Table 2.1. However, the duration of the extension step in the PCR cycles was changed to 1 min. The PCR resulted in an amplification product with the expected size of ~0.7 kb, as determined by agarose gel electrophoresis (Fig. 2.4A). After PCR cycling, 1 unit *Taq* polymerase was added to the PCR mixture to produce 3' A-overhangs and incubated at 72 °C for 10 min. The PCR fragment was ligated into the pSecTag/FRT/V5-His-TOPO vector, which was transformed into OneShot Top10 bacteria cells. The plasmids were amplified, purified and analyzed by *XbaI* restriction digestion (Fig. 2.4B) as described in section II.2.2.1(c)-(f). Restriction digestion of plasmids containing the insert in the right orientation is expected to result in two DNA fragments of ~5 and ~1.2 kb, respectively.

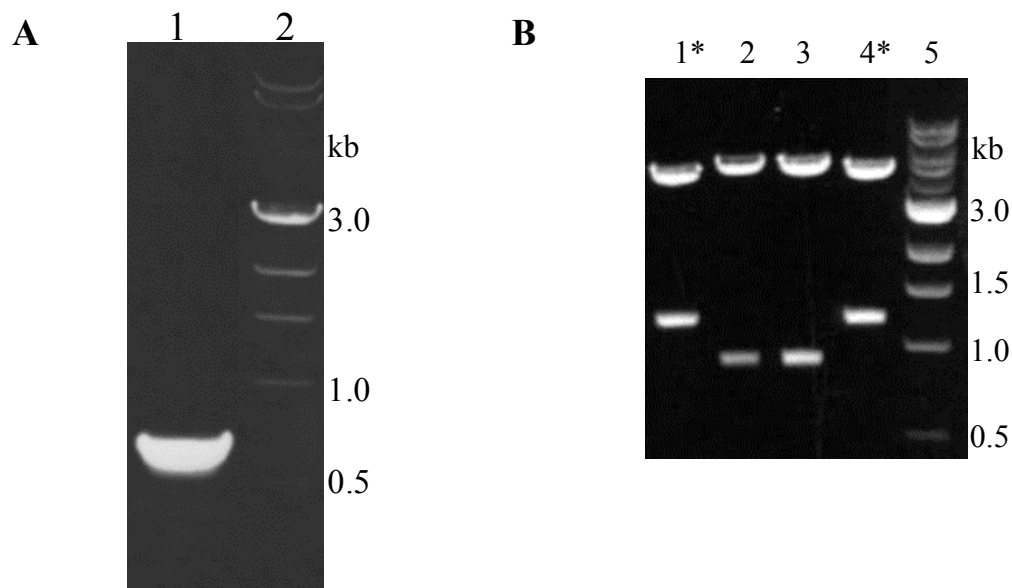

Figure 2.4. Construction of expression plasmid pSECEKshortCorin. To construct a plasmid expressing a soluble corin consisting of only the catalytic domain (EKshortCorin), a cDNA fragment containing nucleotides 2452-3219 of human corin cDNA was amplified by PCR and inserted into the expression vector pSec/FRT/V5-His-TOPO to yield the plasmid pSECEKshortCorin. **(A)** Amplification of bp 2452-3219 of the human corin cDNA by PCR resulted in a DNA fragment of ~0.7 kb in length (*lane 1*), as estimated by agarose gel electrophoresis with a 1-kb DNA ladder as size standard (*lane 2*). **(B)** The DNA fragment was inserted into the expression vector using the TOPO cloning method. The right orientation of the insert within the vector was determined by restriction digestion with *Xba*I, followed by agarose gel electrophoresis analysis. Results of four *Xba*I-digested plasmids are shown in lane 1-4. Positive clones are marked with *. A 1-kb DNA ladder was used as size standard (*lane 5*).

II.2.3 Establishing stable cell lines expressing soluble corin proteins

In 6-well plates, HEK 293 cells were grown to ~90 % confluency. Transient transfection was performed using 10 µg per well of expression plasmids pSECEKsolCorin or pSECEKshortCorin and 1 µg per well of a plasmid, pSV2NEO, containing the bacterial genes encoding aminoglycoside 3'-phosphotransferase, which confers resistance to neomycin (Wu *et al.*, 1991). For each well of HEK 293 cells, 10 µL of the transfection reagent Lipofectamine 2000 was added to the plasmid DNAs, mixed, and incubated according to the manufacturer's instructions. The DNA/Lipofectamine 2000 mixture was added to the HEK 293 cells and replaced by growth medium (MEM- α + 10 % FBS) after 4 h.

To select cells that incorporated the *neo^r* gene, the growth medium was replaced by selection medium (MEM- α + 10 % FBS, 600 µg/mL G418) after 48 h. After another 48 h, cells started to die and detach from the plate surface. After a period of five days, during which fresh selection medium was used daily, surviving cells were spread sparsely. To ensure the cells grow in single colonies, the remaining cells were re-seeded by transferring them from one 1.6 cm²-well into two 55 cm²-culture-dishes each. For 9 days selection medium was replaced every 3 days. Using trypsin-EDTA soaked cloning disks, 150 cell clones were picked and transferred into 24-well plates. After the clones had grown to confluency they were further expanded into 12-well plates and three days later into 6-well plates. When cells became confluent again, 20 µL samples of conditioned medium was taken from each well and tested for corin protein expression by SDS-PAGE and Western blotting using an anti-V5 antibody conjugated with HRP as described in sections II.2.4.2.2 and II.2.4.2.5.

II.2.4 Purification and analysis of soluble corin proteins

II.2.4.1 Purification

II.2.4.1.1 *Affinity chromatography*

The EKsolCorin and EKshortCorin proteins were designed to contain a 6xHis tag at their C-termini, which is commonly used to facilitate protein purification. The 6xHis-tagged proteins can be purified by immobilized metal affinity chromatography on a nickel-nitrilotriacetic acid (Ni-NTA) column (Ford *et al.*, 1991). NTA is a tetradentate chelating adsorbent that occupies four of the six ligand binding sites of the nickel ion. The remaining two sites are available for interactions with the 6xHis-tagged protein. The nickel-bound protein can be eluted by competitive replacement with imidazole.

EKsolCorin and EKshortCorin proteins were purified from 7 L and 5.7 L of conditioned media, respectively, that had been collected from HEK 293 cells stably expressing corin proteins. Upon collection, the medium was passed through a 0.2- μ m cellulose acetate filter (GP Express Plus) to remove cell debris. The Ni-NTA purification step was carried out using an FPLC (Fast Performance Liquid Chromatography) apparatus from Pharmacia (Sweden), which includes a peristaltic pump (P-50), a gradient programmer (GP-250 Plus), a fraction collector (LKB-FRAC-200), and a single path UV monitor (UV-1). The filtered medium was loaded onto a 23-mL Ni-NTA XK26 Superflow column (Qiagen) with a flow rate of 10 mL/min. During column loading, the medium was dialyzed against Buffer A (50 mM Tris-HCl, pH 7.5, 300 mM NaCl) using an in-line Dialyze Direct L Module, placed upstream of the Ni-NTA column. The dialyzing module contains semipermeable capillaries with a MW cutoff size of 5 kDa (Qiagen) and exchanges low-MW components in the conditioned media with Buffer A at a flow rate of 40 mL/min. Subsequently, the column was washed with 10 column volumes of Buffer A containing 10 mM imidazole. The proteins were eluted with a linear imidazole gradient ranging from 10 to 250 mM in Buffer A. The flow rate for wash and elution steps was set at 10 mL/min. Eluate was collected in 8-mL

fractions. The fractions containing soluble corin were identified by SDS-PAGE followed by Western blotting with an anti-V5 antibody as described in sections II.2.4.2.2 and II.2.4.2.5.

II.2.4.1.2 *Ion exchange chromatography*

To achieve a higher degree of purity, EKsolCorin protein was further subjected to an ion-exchange chromatography step in which proteins are separated according to their charge. The isoelectric point for EKsolCorin is 4.9, as calculated based on the EKsolCorin protein sequence using the software program Vector NTI. For the chromatography column, an anion exchange matrix exposing quaternary ammonium groups was selected.

The anion exchange chromatography step was carried out using the FPLC apparatus Äkta Purifier from Amersham, which is computer-controlled by Unicorn 4.0 software and includes a peristaltic pump (P-900), a fraction collector (Frac-900), and a single path UV monitor (UV-900). For all steps, the flow rate was set at 5 mL/min. The fractions eluted from the affinity chromatography that contained EKsolCorin protein were pooled and totaled 255 mL. The eluate contained Tris-buffered saline with 300 mM NaCl and 250 mM imidazole. To reduce the salt concentration, the total volume was diluted 1:3 in Buffer B (20 mM Tris-HCl, pH 8.0). The material was then loaded onto a 5-ml Hi Trap Q Sepharose column (Amersham Biosciences Inc., Piscataway, NJ). The column was equilibrated with Buffer B containing 100 mM NaCl and washed with 10 column volumes Buffer B containing 200 mM NaCl. The proteins were eluted with a 200-750 mM NaCl linear gradient in Buffer B and the eluate collected in 5 mL-fractions. Fractions containing EKsolCorin were identified by Western blotting and pooled. The total pooled fraction volume was 30 mL.

II.2.4.2 Analysis of purified EKsolCorin and EKshortCorin

II.2.4.2.1 Determination of protein concentration by UV spectrophotometry

To determine the protein concentration of purified EKsolCorin, an undiluted sample of 200 μL of the pooled eluate from the anion exchange chromatography step (section II.2.4.1.2) was measured at 280 nm in a UV spectrophotometer, using Buffer B containing 330 mM NaCl as reference. An extinction coefficient ϵ of 1.45 (1 mg/mL) was used to calculate the protein concentration with the equation:

$$c = (A_{\text{sample}} - A_{\text{blank}}) / \epsilon \quad \text{where } A = \text{absorbance (280 nm)}$$
$$c = \text{concentration in mg/mL}$$

II.2.4.2.2 SDS-PAGE

To assess purity and yield of the purified EKsolCorin and EKshortCorin proteins, samples were examined by a number of analytical methods that are described below. Coomassie blue staining, silver staining, and Western blot analysis (II.2.4.2.3-5) were preceded by the separation of the protein samples by SDS-PAGE, a technique for the separation of proteins according to their MW. The protein sample is prepared for electrophoresis by heating it in the presence of SDS, an ionic detergent. SDS binds to the proteins via hydrophobic interactions and causes them to unfold. The SDS-binding occurs in a stoichiometry approximately proportional to the size of the protein. Due to its negatively charged nature, SDS provides the proteins with a total negative charge that is in proportion to their MW. In the presence of an applied electric field, the denatured proteins migrate through the PA gel towards the positive electrode. Hereby, proteins of higher MW travel a shorter distance than low-MW proteins.

To separate EKsolCorin or EKshortCorin samples by SDS-PAGE, protein amounts in the range of 2 ng to 4 µg, depending on the subsequent analytical method, were heated at 95 °C for 5 min in the presence of SDS sample buffer. For most applications, the sample buffer contained 5 % (v/v) of the reducing agent β-ME, which reduces disulfide bonds in proteins. Protein samples (30 µL) and a MW protein standard (10 µL) (see below) were then loaded into the wells of a 10 % (EKsolCorin) or 15 % (EKshortCorin) Tris-glycine-PA gel and separated in the electric field (150 Volts) based on the Lämmli method (Lämmli, 1970).

Applied MW protein standard:
(SeeBlue2 prestained marker)

	Apparent MW (in kDa)
Myosin	250
Phosphorylase B	148
BSA	98
Glutamic dehydrogenase	64
Alcohol dehydrogenase	50
Carbonic anhydrase	36
Myoglobin red	22
Lysozyme	16
Aprotinin	6
Insulin, B chain	4

II.2.4.2.3 *Coomassie blue staining*

Samples of 2 and 4 μg of purified EKsolCorin protein were analyzed by SDS-PAGE as described in section II.2.4.2. To visualize the protein bands, the gel was submerged in 50 mL of Coomassie blue staining solution (see section II.1.7) and stained for 2 h. To remove excessive dye, the gel was destained with 80 mL of 10 % acidic acid for 2 h and then transferred to water. These steps were done at room temperature on a gently shaking platform shaker. To preserve the protein gel, it was air-dried using the DryEase® gel drying system (Invitrogen).

II.2.4.2.4 *Silver staining*

Samples of 15 μL conditioned medium from EKshortCorin secreting HEK 293 cells and 2 μL of purified EKshortCorin were subjected to SDS-PAGE. To visualize the protein bands, the gel was silver stained using the SilverXpress® silver staining kit (Invitrogen) according to the manufacturer's manual. To preserve the protein gel, it was air-dried using the DryEase® gel drying system (Invitrogen).

II.2.4.2.5 *Western blot analysis*

After separation of protein samples by SDS-PAGE, proteins were transferred to a nitrocellulose membrane (0.45 μm) using the Western blotting technique (Towbin *et al.*, 1979). EKsolCorin (~150 kDa) and EKshortCorin (~38 kDa) proteins were transferred at 200 mA for 2.5 h and 2 h, respectively. The completion of the protein transfer was judged by the transfer of the pre-stained protein standard bands. The membrane was then blocked with a solution containing 5 % dried fat-free milk in PBS for 2 h at room temperature, shaking gently on a platform shaker. After a quick rinse with PBS, the membrane was incubated with an HRP-conjugated anti-V5-antibody (1:3000 in PBS, 0.02 % Tween20) for 4 h at room

temperature on a platform shaker. The membrane was then washed three times for 15 min with PBS containing 0.02 % Tween20. To visualize the corin protein bands, the chemiluminescence-based ECL Western blotting reagent from Amersham was used according to the manufacturer's instructions.

II.2.4.2.6 Analytical size exclusion chromatography

In general, size exclusion chromatography (SEC) is used to separate polymer mixtures based on the molecular size of the components. As they pass through a porous-particle stationary phase, the molecules of the sample are subject to differential ex- or inclusion within the packing particles. Larger molecules travel a shorter distance, whereas smaller molecules enter the stationary phase pores more frequently and thereby travel a longer distance. Thus, larger molecules elute earlier in the chromatogram than the smaller components.

To determine the purity of the corin protein after the purification procedure, a sample was analyzed by analytical SEC using the Hitachi Interface D-7000 apparatus. An 100- μ L sample of EKsolCorin protein (~10 μ g) was injected onto a stainless column (7.8 mm x 30 cm) containing TSK gel®G2000SW beads of 5 μ m in diameter (Tosoh). Elution buffer (200 mM K₂PO₄, 150 mM KCl, pH 6.8) was pumped through the column with a flow rate of 0.5 mL/min. Eluted protein molecules were detected by an L-7450 Diode Array Detector, and the data analyzed by the D-7000 software program.

II.2.4.2.7 N-terminal sequencing

The chemical process employed by N-terminal protein sequencing apparatuses to determine the amino acid sequence is derived from the degradation method developed by Edman (Edman, 1950). In this reaction phenylisothiocyanate reacts with the amino acid at the N-terminus under basic conditions to form a phenylthiocarbamyl derivative (PTC-protein). Trifluoroacetic acid (TFA) then cleaves off the first amino acid as its anilinothiazolinone

derivative (ATZ-amino acid) and leaves the new N-terminus for the next degradation cycle. The ATZ-amino acid is then removed by extraction with N-butyl chloride and converted to a phenylthiohydantoin derivative (PTH-amino acid) with 25 % TFA. Subsequently, the PTH-amino acid is transferred to a column for separation, detection, and analysis as described below.

Purified corin protein was analyzed by N-terminal sequencing using the HP 241 Protein Sequencer (Hewlett-Packard Company). Prior to chemical degradation, the protein sample was concentrated by a biphasic sequencing column (Agilent), which contains a reverse phase matrix. Prior to protein sample loading, 1 mL of methanol was passed through the column by applying argon pressure through an HP Sample Prep Stadion G1001A. This step is done to wet the matrix of the column. In preparation for protein binding, 1 mL of sample loading solution, TFA in a 1:49 (v/v) solution with water, was passed through the column with argon pressure. To load the protein sample, approximately 60 μ g protein was mixed with 1 mL of sample loading solution and the solution passed through the column with argon pressure. After a drying period of 1 min, the column was transferred to the protein sequencer, where the protein is subject to the chemical modifications described above. The amino acid derivatives, which were removed from the N-terminus of the protein were separated by a size exclusion column and the chromatogram data were collected by the software program "Protein Sequencer Protocoller" from Hewlett-Packard. To interpret the chromatograms, the retention times and peak shapes of amino acid(s) produced in each degradation cycles were compared to an amino acid standard.

II.2.5 Activation of soluble corin proteins by EK

To activate the recombinant soluble corin, EKsolCorin, 2.5 μg of purified protein was incubated with increasing concentrations of recombinant EK (1 to 10 units/mL) in 100 μL of activation buffer (100 mM Tris-HCl, pH 7.5, 10 mM CaCl_2) at 25 $^\circ\text{C}$ for 2 h. Samples (2 μL) were taken and analyzed by SDS-PAGE under reducing and non-reducing conditions followed by Western blotting using an anti-V5-antibody as described in sections II.2.4.2.2 and II.2.4.2.5.

For activation of large batches, 1 mg of purified EKsolCorin in 40 mL of activation buffer was incubated with 300 units recombinant EK at 25 $^\circ\text{C}$ for 3 h. To remove the recombinant EK, 11 mL of EKapture beads were added to the solution and incubated at room temperature for 15 min. EKapture beads were removed by centrifugation (1,000 rpm, 10 min), and the supernatant was collected and stored at -20 $^\circ\text{C}$ until further use. As a control, an assay buffer without corin protein underwent the same EK activation and removal procedures.

To activate EKshortCorin, ~ 50 μg of purified EKshortCorin protein was incubated with 15 units of recombinant EK in 5 mL activation buffer at 25 $^\circ\text{C}$ for 2 h. The recombinant EK was then removed with 600 μL of EKapture beads that were added to the solution and incubated at room temperature for 15 min. EKapture beads were removed by centrifugation (1,000 rpm, 10 min), and the supernatant was collected and stored at -20 $^\circ\text{C}$ until further use. As a control, an assay buffer without corin protein underwent the same EK activation and removal procedures.

II.2.6 Biochemical characterization of recombinant soluble corin proteins

II.2.6.1 Enzyme kinetics

II.2.6.1.1 *Selecting chromogenic substrates*

The active site of serine proteases is shaped as a cleft where polypeptide substrates bind. To describe the interaction between amino acid residues of an enzyme and its substrates, Schechter and Berger introduced a nomenclature in which the residues of the substrate interaction sites are labeled with ..., P3, P2, P1, P1', P2', P3', ... , and where cleavage occurs between P1 and P1'. The corresponding residues of the enzyme were numbered ..., S3, S2, S1, S1', S2', S3',... (Schechter and Berger, 1967). Serine proteases display different levels of substrate specificity, which greatly depends on the amino acid sequence around the substrate cleavage site, especially the residue at the P1 position.

Corin is predicted to cleave basic residues based on the amino acid residues forming the substrate-binding pocket (Asp979, Gly1007, and Gly1018). To date, however, the enzymatic activity of corin toward small molecule substrates had not been demonstrated, and no studies on the general enzymatic properties of corin including substrate specificity, had been reported. In cell-based assays, corin had been shown to process the cardiac peptides pro-ANP and pro-BNP (Yan *et al.*, 2000; Wu *et al.*, 2002). To identify potential small molecule substrates for the biochemical characterization of corin, we selected a panel of synthetic chromogenic substrates that differed in one or more positions (P1, P2, P3 or P4) from the pro-ANP (Leu-Tyr-Ala-Pro-Arg↓Ser) and pro-BNP (Leu-Arg-Ala-Pro-Arg↓Ser) cleavage sites. As negative controls we included substrates that are unlikely to be cleaved by corin such as kallikrein or elastase substrates. All tested chromogenic substrates are listed by name, peptide sequence, and manufacturer in Table 2.1. Further listed are the names of enzymes that can be used as positive controls in assays for the respective substrate.

The first set of chromogenic assays, carried out in 96-well plates, was performed with purified and activated EKsolCorin protein from section II.2.5. One hundred μL solution of activated EKsolCorin was added to 100 μL of the respective substrate solution that had been prepared in activation buffer. In this assay, the final concentrations for all substrates (500 μM) and the enzyme (40 nM) were fixed. Controls included purified zymogen corin and an assay buffer that had been treated with EK and EKapture beads as described in section II.2.5. The plates were incubated at 37 °C and read at 405 nm wavelength over 30 min at 2-min intervals in a Spectra MAX 250 plate reader. In this experiment, substrates, which were efficiently cleaved by EKsolCorin, were identified by comparing the substrate conversion rate (measured in mOD/min) of active EKsolCorin with the respective controls of inactive zymogen EKsolCorin and EK-treated buffer.

For some substrates, the value of OD reading of active EKsolCorin was not significantly different from that of the negative controls. For a selection of these substrates including S-2238, S-2251, S-2266, S-2288, S-2484, S-2765, L-1300, L-1720 and L-1725, additional assays were carried out to assess the quality of the substrates. Positive control enzymes known to cleave the respective substrates (see Table 2.1) were used under published assay conditions to confirm the K_m values reported in the literature (Hemker, 1993; Chromogenix product range handbook, 2003). These experiments ensured the quality and the correct assay conditions for the chromogenic substrates that corin had failed to cleave.

Table 2.1. Chromogenic substrates tested for a kinetic EKsolCorin assay

Substrate	Peptide sequence	Substrate for ...	Manufacturer
S-2222	Bz-Ile-Glu-(γ -OR)-Gly-Arg-pNA·HCl	Factor Xa	Chromogenix
S-2238	H-D-Phe-Pip-Arg-pNA·2HCl	Thrombin	Chromogenix
S-2251	H-D-Val-Leu-Lys-pNA·2HCl	Plasmin	Chromogenix
S-2266	H-D-Val-Leu-Arg-pNA·2HCl	Kallikrein Factor XIa	Chromogenix
S-2288	H-D-Ile-Pro-Arg-pNA·2HCl	t-PA	Chromogenix
S-2302	H-D-Pro-Phe-Arg-pNA·2HCl	Kallikrein Factor XIIa	Chromogenix
S-2366	pyroGlu-Pro-Arg-pNA·HCl	Protein C Factor XIa	Chromogenix
S-2403	pyroGlu-Phe-Lys-pNA·HCl	Plasmin	Chromogenix
S-2444	pyroGlu-Gly-Arg-pNA·HCl	Urokinase	Chromogenix
S-2484	pyroGlu-Pro-Val-pNA	Elastase	Chromogenix
S-2765	N- α -Z-D-Arg-Gly-Arg-pNA·2HCl	Xa	Chromogenix
L-1220	Z-Arg-pNA·HCl	Trypsin	Bachem
L-1240	Z-Lys-Arg·2HCl	Serine proteases	Bachem
L-1242	Z-Phe-Arg-pNA·HCl	Cathepsin Papain	Bachem
L-1250	Z-Tyr-Lys-Arg-pNA·2TFA	Kex2 endoprotease	Bachem
L-1285	H-Gly-Arg-pNA	Serine proteases	Bachem
L-1300	H-D-Ile-Phe-Lys-pNA	Plasmin	Bachem
L-1635	Suc-Ala-Glu-Pro-Phe-pNA	Elastase	Bachem
L-1720	Suc-Ala-Ala-Pro-Arg-pNA	Trypsin	Bachem
L-1725	Suc-Ala-Ala-Pro-Lys-pNA	Trypsin	Bachem
L-1990	Sar-Pro-Arg-pNA	Thrombin	Bachem

II.2.6.1.2 Determination of kinetic constants of corin using selected chromogenic substrates

Kinetic constants were determined using a panel of chromogenic substrates that were selected based on the data obtained from section II.2.6.1.1. For each assay carried out in 96-well plates, 50 μ L of substrates (final concentrations ranging from 0.2 to 2 mM in activation buffer) were mixed with 50 μ L of activated EKsolCorin (final concentration of 58 nM). The plates were incubated at 37 °C and read at 405 nm wave length over 15 min at 20 s intervals in a Spectra MAX 250 plate reader (Molecular Devices Corp., Sunnyvale, CA). In these experiments, controls included purified EKsolCorin that was not activated by EK and an assay buffer that underwent the same EK treatment and removal procedures. These control values, which were minimal, were subtracted as the background. In addition, plasmin (for S-2222, S-2251, S-2302, S-2366, S-2403, and S-2444), kallikrein (for S-2266 and S-2288), thrombin (for S-2238), trypsin (for S-2765), and elastase (for S-2484) were used as positive controls under the conditions recommended by the manufacturer. K_m and V_{max} values were determined by Lineweaver-Burk double-reciprocal plot. Each enzymatic assay was carried out in triplicate and repeated at least three times.

In the chromogenic assay for corin, any residual EK activity could falsify the kinetic measurements on the used peptide substrates. So it had to be demonstrated that the measured kinetic data were derived from the catalytic activity of corin but not EK. Therefore, we determined the K_m values for EK and corin side by side for a selection of chromogenic substrates (S-2222, S-2266, S-2302, S-2366, S-2403, S-2444). Since enzymes have a specific K_m value for a specific substrate, the K_m values can be used to distinguish two enzymes.

Depending on the substrate, different concentrations of substrates ranging from 0.125 to 10 mM were prepared in activation buffer. In this assay, a preparation of activated EKsolCorin from section II.2.5 was used. EK was prepared as followed: 2.9 μ L EK was added to 10 mL assay buffer, resulting in a 0.5 units/mL solution. It should be noted that corin and EK concentrations were not the same. However, this does not affect the determination of K_m , since the K_m is independent of the enzyme concentration. As in the corin assay, 50 μ L substrate solution was mixed with either 50 μ L enzyme solution or assay buffer. The measurement of the kinetic rate and the determination of the K_m values for EK and corin were done as described for the corin assay above. Each enzymatic assay was carried out in triplicate and repeated at least twice.

The K_m values for corin and EK, respectively, were ~ 2.21 and ~ 1.47 mM (S-2222); >50 and ~ 6.49 mM (S-2266); ~ 3.48 and ~ 6.55 mM (S-2302); ~ 4.07 and ~ 2.42 mM (S-2366); ~ 1.37 and ~ 0.90 mM (S-2403); and ~ 17.0 and ~ 2.62 mM (S-2444). Overall, corin and EK had different K_m values for the substrates tested. For two substrates, S-2266 and S-2444, EK had a significantly lower K_m value than corin, whereas EK had a higher K_m value for the substrate S-2302 than corin. These data ensure that the catalytic activity in the kinetic assay was derived from corin but not EK.

II.2.6.2 Inhibitor assays

Effects of protease inhibitors on EKsolCorin were tested in an assay using the chromogenic substrate S-2403. In preparation of the inhibitor assay, inhibitor stock solutions were prepared according to Table 2.2.

Table 2.2. Preparation of inhibitor stock solutions

Inhibitor	Diluent	Concentration
Antipain-dihydrochloride	H ₂ O	20 mM
Pepstatin	Methanol	1 mM
Bestatin	0.15 M NaCl	1 mM
Chymostatin	Glacial acetic acid	10 mM
Phosphoramidon	H ₂ O	10 mM
Aprotinin	H ₂ O	1 mM
Leupeptin	H ₂ O	10 mM
TPCK	Ethanol	50 mM
TLCK	H ₂ O	50 mM
Soybean trypsin inhibitor	H ₂ O	10 mM
EDTA	H ₂ O	500 mM
Benzamidine	Ethanol	100 mM
PMSF	2-Propanol	100 mM

The inhibitor stock solutions from Table 2.2 were diluted with H₂O to prepare three different concentrations for each inhibitor: 400 mM, 200 mM, and 100 mM for EDTA; 10 mM, 1 mM, and 100 μ M for bestatin, chymostatin, phosphoramidon, TPCK, TLCK, and PMSF; 1 mM, 100 μ M, and 10 μ M for antipain-dihydrochloride, pepstatin, leupeptin, and benzamidine; 10 μ M, 1 μ M, and 0.1 μ M for aprotinin and soybean trypsin inhibitor.

In each experiment, 45 μL of activated EKsolCorin (final concentration of 104 nM) was mixed with 5 μL of the respective inhibitor in three different concentrations. The final inhibitor concentrations were between 0.01 μM and 40 mM. The samples were incubated at 37 $^{\circ}\text{C}$ for 30 min. To measure the remaining hydrolytic activity of EKsolCorin, 50 μL of S-2403 (final concentration of 500 μM) was added to the mixture and the absorbance measured at 405 nm after 2 h. In controls containing no inhibitor, 5 μL of the buffer used for the highest inhibitor concentration was used. For example, for the bestatin control without inhibitor, 5 μL of a 1:10 dilution of 0.15 M NaCl was added to the reaction mixture. Inhibition in percent was determined by comparing the absorbance at 405 nm from inhibitor-containing samples to the controls without inhibitor. Each experiment was performed in triplicate and repeated at least three times.

To compare the effects of inhibitors on EKshortCorin and EKsolCorin, the assay was repeated with a selection of inhibitors using the chromogenic substrate S-2403. Inhibitors were prepared in the following concentrations: EDTA (200 mM), pepstatin (500 μM), benzamidine (50 mM and 500 μM), PMSF (50 mM and 500 μM), leupeptin (500 μM and 50 μM) and soybean trypsin inhibitor (5 μM and 0.5 μM). In each experiment, 45 μL of activated EKshortCorin or EKsolCorin (final concentration of 50 nM) was mixed with 5 μL of an inhibitor (final concentrations ranging from 0.05 μM to 20 mM) and incubated at 37 $^{\circ}\text{C}$ for 30 min. The substrate S-2403 (final concentration of 500 μM) was added to the mixture and the absorbance was measured at 405 nm after 2 h. Each assay was performed in triplicate and repeated at least three times.

II.2.6.3 Effect of human plasma on pro-ANP processing activity of EKsolCorin

Human blood plasma contains various serine protease inhibitors (serpins) including α -1-antitrypsin, antithrombin III (AT-III) and others. Serpins have an inhibitory effect on a wide range of serine proteases such as thrombin, factor X, trypsin, and components of the complement system. For AT-III and some other serpins, this inhibitory effect can be enhanced several thousand times by heparin, a polysaccharide that binds to the inhibitor and causes an allosterical change (Huntington *et al.*, 1996). To determine whether plasma contains a corin inhibitor, we studied the ability of EKsolCorin to process pro-ANP in the presence of plasma with or without heparin.

A heparin stock solution of 500 units/mL (2.762 mg/mL) in H₂O was prepared and added to pooled human plasma samples (Sigma) to yield heparin concentration of 5 units/mL or 50 units/mL, respectively. Different volumes of the plasma/heparin mixtures or plasma without heparin were added to 10 μ L of activated EKsolCorin protein (see section II.2.5), and the volume adjusted to 50 μ L with OPTI-MEM. In the samples, the final concentration for EKsolCorin was 40 nM, and plasma concentrations were 0, 25, 50, and 75 %, respectively. In a similar manner, the following controls were prepared in 0 or 75 % plasma with heparin: a buffer control with EK and a sample of non-activated EKsolCorin (both from section II.2.5). All samples were incubated at 37 °C for 10 min. The plasma/corin mixtures were then transferred to a tube containing 1.2 mL of conditioned medium containing recombinant human pro-ANP (see section II.2.7.4) and incubated at 37 °C for 4 h. Pro-ANP, its derivatives, and corin protein were immunoprecipitated from the sample with an anti-V5 antibody as described in section II.2.7.2. and analyzed by SDS-PAGE and Western Blotting.

II.2.7 Pro-ANP processing assays for R801A corin, WTsolCorin, EKsolCorin, and EKshortCorin

The human corin protein contains a conserved activation cleavage sequence Arg801-Ile802-Leu803-Gly804-Gly805 (Yan *et al.*, 1999). To examine the functional importance of the activation cleavage of human corin, we constructed a plasmid expressing a mutant corin in which the activation site is abolished. A PCR-based mutagenesis method was used to construct a plasmid vector, pcDNACorinR801A, encoding corin activation cleavage site mutant R801A in which Arg801 is replaced by Ala (see section II.3.1.2).

II.2.7.1 Co-transfection of pro-ANP and corin mutants R801A or WTsolCorin

HEK 293 cells in 6-well plates were grown to ~90 % confluency in growth medium. Cells were co-transfected with plasmids expressing WT corin, corin active site mutant S985A (Yan *et al.*, 2000), activation cleavage site mutant R801A, and a plasmid expressing pro-ANP using the transfection reagent Lipofectamine 2000 according to the manufacturer's protocol. The transfected cells were incubated in serum-free OPTI-MEM I, in a cell culture incubator at 37 °C. After 16 h, the conditioned media containing recombinant pro-ANP were collected. Pro-ANP and its derivatives were analyzed by immunoprecipitation, SDS-PAGE, and Western blotting as described in the following section.

II.2.7.2 Analysis of pro-ANP and its derivatives in conditioned medium

To detect pro-ANP and its derivatives, immunoprecipitation was used to concentrate the proteins from the conditioned medium from HEK 293 cells transiently expressing pro-ANP. To capture pro-ANP and ANP proteins, 1.5 µL of an anti-V5 antibody was added to 2 mL of the conditioned medium and incubated at room temperature for 90 min. The antibody recognizes the viral V5 tag at the C-terminus of the recombinant proteins. To precipitate the

antibody-protein complex, 70 μ L of a slurry of protein A sepharose beads in PBS was added to the samples and incubated for an additional 30 min at room temperature in a rotating apparatus. The protein A beads were collected by a quick spin at 13,000 rpm, and the supernatant was discarded. Then the sepharose pellet was subjected to two wash cycles in which the beads were washed with 1 mL PBS for 5 min on a rotating apparatus, followed by a quick spin at 13,000 rpm to bring down the beads. The supernatant was discarded. To elute the immunoprecipitated recombinant proteins from the beads, 50 μ L of 2 x SDS sample buffer containing β -ME was added, and the samples heated at 95 $^{\circ}$ C for 5 min. Thirty μ L of the protein samples was subjected to SDS-PAGE using a 15 % Tris-glycine PA gel (see section II.2.4.2.2) and Western blot analysis (see section II.2.4.2.5). Due to the low MW of pro-ANP (~24 kDa) and ANP (~7 kDa), the Western blot transfer time at 200 Volts was shortened to 1.5 h.

II.2.7.3 Detection of corin proteins in cell lysates

To confirm the expression of corin proteins, cells were lysed by adding 200 μ L of lysis buffer (see section II.1.8.) to each well. The cell lysates were collected from the wells using a cell scraper and transferred to 1.5-mL tubes. To break down genomic DNA that causes the cell lysates to be viscous, the lysates were passed through an 18-gauge needle 8-10 times. Then 25 μ L of cell lysates was mixed with 2 x SDS sample buffer containing β -ME and heated at 95 $^{\circ}$ C for 5 min. The protein samples were subjected to SDS-PAGE followed by Western blot analysis (see sections II.2.4.2.2 and II.2.4.2.5).

II.2.7.4 Production of recombinant pro-ANP in HEK 293 cells

HEK 293 cells were grown in a 75 cm^2 -cell culture flask. The confluent cells were transfected with 25 μ g of the expression plasmid pProANP (Yan *et al.*, 2000) using 70 μ L of Lipofectamine 2000 according to the manufacturer's protocol. After the transfection, the cells were washed twice with PBS and then incubated in serum-free OPTI-MEM for 16 h at

37 °C in a cell culture incubator. The conditioned medium (15 mL) containing pro-ANP was collected and subjected to a 5-min centrifugation step at 1000 rpm to remove cell debris. The supernatant was transferred to a fresh 15-mL tube and immediately used for pro-ANP processing assays.

II.2.7.5 Sequence specificity of EKsolCorin for pro-ANP

Expression vectors for WT pro-ANP, and pro-ANP mutants R98A, R101A, and R102A (Yan *et al.*, 2000) were transiently transfected into HEK 293 cells as in the previous section. After 14 h, the conditioned media were collected, aliquoted into 1.5 mL, and 150 µL activated or non-activated corin EKsolCorin (25 ng/µL) was added. For each pro-ANP mutant, a control sample with 150 µL of EK-treated buffer was prepared. Samples were incubated at 37 °C for 4 h. Corin protein was detected in the conditioned medium by SDS-PAGE followed by Western blot analysis using an anti-V5 antibody conjugated with HRP. To examine pro-ANP processing, recombinant pro-ANP and its derivatives were immunoprecipitated from the conditioned medium by an anti-V5 antibody. Proteins were separated by SDS-PAGE and analyzed by Western blotting using an anti-V5-antibody conjugated with HRP (see sections II.2.4.2.2 and II.2.4.2.5).

II.2.7.6 Pro-ANP processing assay for EKsolCorin and EKshortCorin

For the functional pro-ANP processing assay, 1 µg of purified EKsolCorin or EKshortCorin in 1 mL activation buffer was incubated at 25 °C for 2 h with increasing concentrations of recombinant EK (1 to 10 units/mL). EK was then removed from the samples by adding 30 µL of EKapture beads per unit of EK. After 15 min at room temperature, beads were spun down by centrifugation at 1000 rpm for 10 min, and the supernatants were collected. Then 100 µL of EK-treated supernatant was each added to 2-mL aliquots of conditioned medium containing recombinant human pro-ANP (see section II.2.7.4) and incubated at 37 °C for 4 h. Recombinant human corin, pro-ANP and pro-ANP derivatives were immuno-

precipitated with an anti-V5 antibody and separated by SDS-PAGE in the presence of 5 % β -ME (see section II.2.4.2.2). The proteins were then analyzed by Western blotting using an anti-V5 antibody conjugated with HRP (see section II.2.4.2.5).

II.2.7.7 cGMP assay to determine activity of ANP

To examine the activity of the corin-processed ANP, a cGMP assay was performed using the cGMP Direct Biotrak EIA kit (Amersham). In this assay, BHK cells were grown in 96-well plates in MEM supplemented with 10 % FBS and 1 % of L-glutamine. Confluent cells were washed once with serum-free medium. The conditioned medium (180 μ L) containing recombinant pro-ANP and its derivatives from transfected HEK 293 cells was added to each well and incubated at 37 °C for 10 min. The cells were lysed by addition of a lysis buffer (20 μ L/well) containing 2 % dodecyl trimethyl-ammonium and 50 mM sodium acetate, pH 5.8. The intracellular cGMP concentration in ANP-stimulated BHK cells was determined with the Biotrak EIA kit according to the manufacturer's protocol. Each experimental condition was assayed in quadruplicate.

II.3 Generation and Functional Analysis of Transmembrane Corin Mutants

To understand how different extracellular domains of corin contribute to its activity in pro-ANP processing, we constructed a series of mutants by deleting domains within the extracellular region of corin (Table 2.3, Fig. 2.5). All these mutants were designed to contain the transmembrane domain, allowing us to examine pro-ANP processing in cell-based assays.

Table 2.3. Summary of the PCR-based strategy to construct plasmids encoding corin deletion mutants. The numbering for nucleotides and amino acids is based on the full-length human corin cDNA and its deduced amino acid sequence (Yan *et al.* 1999).

Mutant	PCR fragment 1 (bp of cDNA)	PCR fragment 2 (bp of cDNA)	Amino acids deleted
$\Delta R1-5$	94 - 870	1340 - 3222	260 - 415
$\Delta Fz2$	94 - 1450	1822 - 3222	453 - 567
$\Delta Fz1R1$	94 - 462	1006 - 3222	124 - 304
$\Delta Fz1R12$	94 - 462	1114 - 3222	124 - 340
$\Delta Fz1R1-3$	94 - 462	1225 - 3222	124 - 377
$\Delta Fz1R1-4$	94 - 462	1337 - 3222	124 - 414
$\Delta R1$	94 - 870	1006 - 3222	260 - 304
$\Delta R12$	94 - 870	1114 - 3222	260 - 340
$\Delta R1-3$	94 - 870	1225 - 3222	260 - 377
$\Delta R1-4$	94 - 870	1337 - 3222	260 - 414
$\Delta R2$	94 - 1005	1114 - 3222	305 - 340
$\Delta R3$	94 - 1113	1225 - 3222	341 - 377
$\Delta R4$	94 - 1224	1336 - 3222	378 - 414
$\Delta R5$	94 - 1336	1450 - 3222	415 - 452

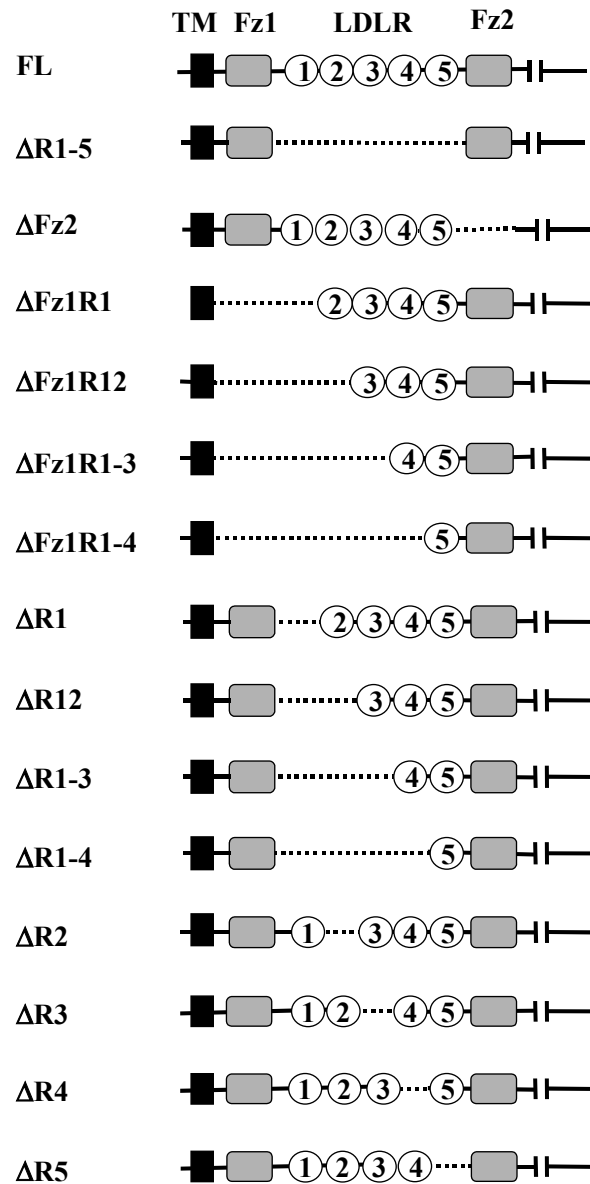

Figure 2.5. Schematic presentation of full-length corin and mutant corins with deletions in the propeptide. Schematic diagrams of the full-length corin (*FL*) and mutant corins $\Delta R1-5$, $\Delta Fz2$, $\Delta Fz1R1$, $\Delta Fz1R2$, $\Delta Fz1R1-3$, $\Delta Fz1R1-4$, $\Delta R1$, $\Delta R12$, $\Delta R1-3$, $\Delta R1-4$, $\Delta R2$, $\Delta R3$, $\Delta R4$, and $\Delta R5$. Dotted lines represent deleted domains. The domain structures C-terminal to Fz2 domain are omitted.

II.3.1 Generation of expression plasmids encoding transmembrane mutant corin proteins

II.3.1.1 Generation of plasmids encoding deletion mutant corin proteins

To construct expression vectors encoding various corin deletion mutants, two DNA fragments amplified by PCR using *Pfu* polymerase were sequentially ligated into the vector pcDNA4/HisMaxC from Invitrogen (Fig. 2.6). The recombinant proteins resulting from this vector contain an Xpress and a 6xHis tag on the N-terminus.

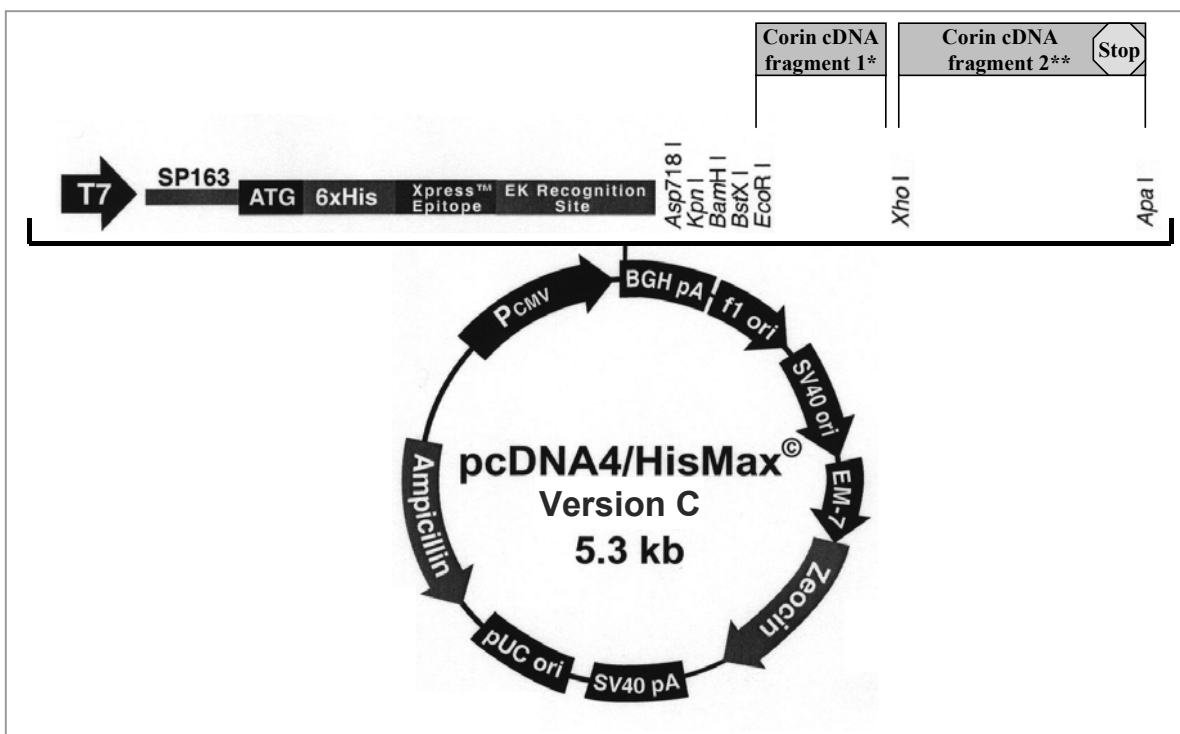

Figure 2.6. Plasmid for the expression of membrane-bound corin deletion mutants. Schematic presentation of the expression vector pcDNA4/HisMaxC for the expression of corin deletion mutants listed in Table 2.3. PCR-derived corin fragments were ligated into the vector at restriction sites *EcoRI* and *XhoI* (fragment 1) or at restriction sites *XhoI* and *ApaI* (fragment 2).

Previously, an expression plasmid encoding a full-length corin protein had been constructed in the same way (Knappe, 1999). In addition to the human corin amino acid sequence 1-1042, full-length corin contains two additional amino acids, Leu-Glu, as a result of the addition of the *XhoI* restriction site CTC GAG. These two residues are located between the corin amino acids 124 and 125. In a cell-based pro-ANP processing assay, no functional difference was observed between WT corin and full-length corin, confirming that this two-amino-acid insertion did not affect pro-ANP processing.

(a) PCR amplification

A human corin cDNA fragment that included the 5'- end of the corin cDNA was used for PCR to amplify fragment 1, which was flanked by an *EcoRI* and an *XhoI* restriction site, at the 5'- or 3'- end, respectively. Table 2.4 summarizes the primers that were used to generate fragment 1 for various corin deletion mutants.

The expression vector pcDNAcorin (Yan *et al.*, 2000) was used as template to amplify fragment 2, which carried an *XhoI* site at the 5'- and an *ApaI* site at the 3'- end. Table 2.5 summarizes the primers that were used to generate fragment 2 for various corin deletion mutants.

Table 2.4. Summary of oligonucleotide primers and amplified cDNA fragments for the first PCR step to generate various corin deletion mutant expression vectors. Reverse oligonucleotide primers and amplified cDNA fragment 1, as shown in Fig. 2.2, are listed. The nucleotides representing the restriction site for *XhoI* are shown in bold letters. The forward primer used for fragment 1 of all deletion mutants was 5'- GGGG **GAA TTC** ATG AAA CAG TCT CCT GCC CTC GCT CCG GAA GAG C -3', with the bold letters representing the *EcoRI* restriction site.

Mutant	Reverse Primer 5'→3' Fragment 1	cDNA Sequence Fragment 1
ΔFz1R1		
ΔFz1R12	GGGG CTC GAG CGT AGT CCA GGC TGG AAC	94-462
ΔFz1R1-3	GTG TTG GTC G	
ΔFz1R1-4		
ΔR1-5	GGGG CTC GAG AGG TGA GAA GCA AAT TCT GCT GAC ATT GC	94 - 870
ΔFz2	GGGG CTC GAG GCA GTT CTC CTC ATC ACT CCC ATC CTT GC	94-1449
ΔR1		
ΔR12	GGGG CTC GAG CAA TTG CTT TCC GTT TTC	94-894
ΔR1-3	CTG CTG AGG	
ΔR1-4		
ΔR2	GGGG CTC GAG GCA ATG AGC CTC GTC ACT CCA GTC	94-1005
ΔR3	GGGG CTC GAG ACA GTT TTG CTC ATC ACT CAA ATC CCC AC	94-1113
ΔR4	GGGG CTC GAG GCA GTT GAC CTC GTC GGA CTT ATC CAC	94-1224
ΔR5	GGGG CTC GAG AGT CAA TGT GAA CCA ATT ACA TTG GAA CTC TG	94-1335

Table 2.5. Summary of the second construction step for various corin deletion mutant expression vectors. Forward oligonucleotide primers and amplified cDNA fragment 2, as shown in Fig. 2.2, are listed. The nucleotides representing the restriction site for *XhoI* are shown in bold letters. The reverse primer used for fragment 2 of all deletion mutants was 5'-GGGG **GAG CCC** TTA GTT TAG GAG AAA GGT CTG GAT GTA AAT CTG-3', with the bold letters representing the *Apal* restriction site.

Mutant	Forward Primer 5'→3' Fragment 2	cDNA Sequence Fragment 2
ΔR1-5	GGGG CTC GAG AGT CAA TGT GAA CCA ATT ACA TTG GAA CTC TG	1450-3222
ΔFz2	GGGG CTC GAG GTG GAA GAA TGC TCA CCT AGT CAT TTC AAG	1822-3222
ΔFz1R1	GGGG CTC GAG AAC TGC AGC GAG AAT CTG TTT CAC TG	1006-3222
ΔFz1R12	GGGG CTC GAG GAT TGC AAT CCC ACA ACA GAG CAT CG	1114-3222
ΔFz1R1-3	GGGG CTC GAG TCC TGT CAC AGC CAG GGT CTG GTG G	1225-3222
ΔFz1R1-4	GGGG CTC GAG AGC GTC ATT CAG ACT TCA TGT CAA GAA G	1336-3222
ΔR1	GGGG CTC GAG AAC TGC AGC GAG AAT CTG TTT CAC TG	1006-3222
ΔR12	GGGG CTC GAG GAT TGC AAT CCC ACA ACA GAG CAT CG	1114-3222
ΔR1-3	GGGG CTC GAG TCC TGT CAC AGC CAG GGT CTG GTG G	1225-3222
ΔR1-4	GGGG CTC GAG AGC GTC ATT CAG ACT TCA TGT CAA GAA G	1337-3222
ΔR2	GGGG CTC GAG GCA ATG AGCCTC GTC ACT CCA GTC	1114-3222
ΔR3	GGGG CTC GAG ACA GTT TTG CTC ATC ACT CAA ATC CCC AC	1225-3222
ΔR4	GGGG CTC GAG GCA GTT GAC CTC GTC GGA CTT ATC CAC	1336-3222
ΔR5	GGGG CTC GAG AGT CAA TGT GAA CCA ATT ACA TTG GAA CTC TG	1450-3222

The following reagents were mixed for the PCR:

Reagent	Volume
PCR buffer	5 μ L
DNA template (50 ng/ μ L)	2 μ L
dNTPmix (10 mM)	4 μ L
Forward Primer (25 μ M)	2 μ L
Reverse Primer (25 μ M)	2 μ L
H ₂ O	34 μ L
<i>Pfu</i> DNA polymerase (2.5 units/ μ L)	1 μ L
Total:	50 μL

The PCR cycle program was as followed:

Cycles		T	Duration
PCR step	No. of cycles	in $^{\circ}$ C	per cycle
Denaturation	1	95	2 min
Denaturation	30	95	30 s
Annealing		58	1 min
Extension		72	2.5 min
Final Extension	1	72	10 min

Five μ L of each PCR mixture was separated by agarose gel electrophoresis (1 %, TAE) and DNA bands visualized under UV light in gels containing EtBr. The remaining 45 μ L was subjected to a quick purification step using the QIAquick PCR purification kit from Qiagen following the manufacturer's instructions.

(b) Restriction digestion of PCR products

To prepare the PCR product for ligation into the expression vector, PCR products were digested with either *EcoRI/XhoI* (fragment 1) or *XhoI/ApaI* (fragment 2). To digest the vector, 0.5 µg of pcDNA4/HisMax C was added to 5 µL NEBuffer 4, 0.5 µL BSA and 20 units (1 µL) of each of the restriction enzymes. The volume was adjusted to 50 µL with H₂O. To digest cDNA inserts, 2 µg of PCR product was incubated with the same reaction mixture as for the vector digest. The restriction digestions were incubated at 37 °C for at least 4 h. When *ApaI* was used, the reaction was performed at 25 °C for at least an additional 4 h. Prior to ligation, digested PCR fragments were gel-purified (see section II.2.1 (c)) and the DNA samples were analyzed by agarose gel electrophoresis to estimate DNA concentrations.

(c) Ligation into vector pcDNA4/HisMax C

Depending on the estimated concentration of restriction digested vector and insert preparations, different volumes of each DNA solution were added to 1.2 µL of T4 ligase buffer and 1 µL of T4 ligase (400 units). The final vector to insert ratio was 1:10, and the final volume of the ligation reaction was 12 µL. The reaction was performed at 16 °C overnight.

(d) Transformation into *E. coli* DH5 α

Transformation was performed using of 3 µL of ligation mixture as described in section II.2.2.1 (e).

(e) Restriction digest

Eight bacterial colonies from the previous section were each inoculated in 1.5 mL LB medium containing ampicillin (100 µg/mL). The bacterial cultures were grown for 16 h at 37 °C in a vigorously shaking (250 rpm) incubator. Plasmids were isolated using a QIAprep Spin Miniprep plasmid purification kit (Qiagen) according to the manufacturer's manual. To confirm the ligation of corin fragments 1 (see Table 2.4), ~1 µg of plasmid samples was digested with 10 units of each, *XhoI* and *EcoRI* in *EcoRI*-buffer, and BSA (100 µg/mL) for 1 h at 37 °C. To confirm the ligation of corin fragments 2 (see Table 2.5), ~1 µg of plasmid samples was digested with 10 units of each, *XhoI* and *ApaI* in NEBuffer4, and BSA (100 µg/mL) for 1 h at 37 °C, and an additional h at 25 °C. The digested plasmid samples were analyzed by agarose gel electrophoresis using a 1-kb DNA ladder as size standard. Bacterial colonies containing an insert of the right size were each inoculated in 250 mL of LB medium containing ampicillin (100 µg/mL) and grown as described above. Plasmids were purified using a QIAfilter Plasmid Maxi kit (Qiagen) following the manufacturer's instructions and the plasmid preparations stored at -20 °C. For each corin deletion mutant, the sequence of the entire corin insert was confirmed by direct DNA sequencing.

II.3.1.2 Generation of plasmids encoding mutant corin proteins with single amino acid substitutions

To test the effect of point mutations in LDLR repeats 1-4 on the pro-ANP processing activity of corin, a highly conserved Asp residue near the C-terminus of each individual LDLR repeat was replaced by a Tyr residue. The expression plasmids encoding mutant corins D300Y, D336Y, D373Y, and D410Y (Fig. 2.7) were generated by site-directed mutagenesis.

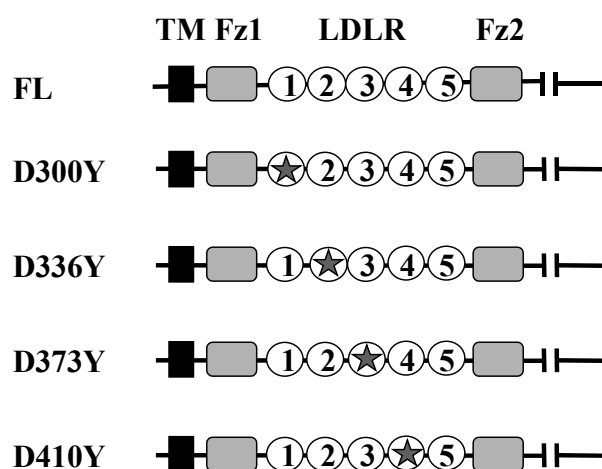

Figure 2.7. Schematic presentation of full-length corin and mutant corins with single amino acid substitutions in the propeptide. Schematic diagrams of the full-length corin (*FL*) and corin mutants D300Y, D336Y, D373Y, and D410Y. Stars indicate the LDLR repeats, in which a conserved Asp residue was mutated to Tyr. The domain structures C-terminal to Fz2 domain are omitted.

To construct plasmids expressing the corin point mutants D300Y, D336Y, D373Y and D410Y (Fig. 2.7) mutagenesis was performed using the QuikChange II Site-Directed Mutagenesis Kit II XL from Stratagene according to the manufacturer's recommendations. Full-length corin (Knappe, 1999) served as template in this PCR-based mutagenesis experiment. The same method was used to generate the corin activation site mutant R801A (see section II.2.7) with pcDNACorinV5 (Yan *et al.*, 2000) as PCR template.

The mutagenesis oligonucleotide primers were designed in such a way that the desired mutation (see Table 2.5) was located in the middle of the primer, which was about 35 bp in length. For optimal amplification, the GC contents of all primers were selected to be around ~ 50 % and all primers contained one or more C or G bases at both ends. The melting temperature (T_m) of the primers was chosen to be >75 °C as calculated by the following formula:

$$T_m = 81.5 + 0.41 (\%GC) - 675/N - \% \text{ mismatch}$$

where N = primer length in bases

Table 2.5. List of oligonucleotide primers used to create different corin point mutations by PCR-based site-directed mutagenesis. The mismatched nucleotides are indicated by bold-typed and underlined letters. A complementary copy of each primer was used as the second primer in the amplification step.

Mutant	Mutagenesis primer 5' → 3'
D300Y	CTGTGACGACTGGAGT <u>T</u> ACGAGGCTCATTGCAAC
D336Y	GACTGTGGGGATTTGAGT <u>T</u> ATGAGCAAACTGTGATTGC
D373Y	GACTGTGTGGATAAGTCC <u>T</u> ACGAGGTCAACTGCTCC
D410Y	GACTGCAAGGATGGGAGT <u>T</u> ATGAGGAGAACTGCAG
R801A	C CGA ATG AAC AAA <u>GCA</u> ATC CTT GGA GGT CG

The following reagents were used for the PCR amplification:

Reagent	Volume
PCR buffer	5 μ L
DNA template (5 ng/ μ L)	2 μ L
Forward primer (62.5 ng/ μ L)	2 μ L
Reverse primer (62.5 ng/ μ L)	2 μ L
dNTPmix	1 μ L
QuikSolution™	3 μ L
H ₂ O	34 μ L
<i>Pfu</i> DNA polymerase (2.5 units/ μ L)	1 μ L
Total:	50 μL

The PCR cycle program was as followed:

Cycles		T	Duration
PCR step	No. of cycles	in °C	per cycle
Denaturation	1	95	1 min
Denaturation	18	95	50 s
Annealing		60	50 s
Extension		68	16 min
Final	1	68	7 min

To remove double-strand template DNA from the reaction, 10 units of *DpnI* restriction enzyme, which recognizes methylated nucleotides, was added to the reaction and incubated for 2 h. Then, 3 μ L of the reaction mixture was transformed into OneShot Top 10 bacteria cells. Plasmids were amplified and purified as described in section II.2.2.1 (e) and (f). For each corin point mutant, the sequence of the entire corin insert was confirmed by direct DNA sequencing.

II.3.2 Functional characterization of transmembrane corin mutants

II.3.2.1 Pro-ANP processing assay for transmembrane corin mutants

HEK 293 cells in 6-well plates were grown to ~90 % confluency in growth medium. Cells were transfected with plasmids expressing corin propeptide mutants (see Figs. 2.5 and 2.7) using Lipofectamine 2000 according to the manufacturer's protocol. After the transfection, the transfected cells were incubated in growth medium for 16 h. Then the growth medium was aspirated from the cells, and the cells were washed twice with PBS to remove traces of serum. Then 2 mL of conditioned medium containing pro-ANP (see section II.2.7.4) was added to the cells expressing various corin mutants and incubated at 37 °C for 4 h. Corin mutant proteins were detected in the cell lysate as described in section II.2.7.3 using an anti-Xpress antibody conjugated with HRP for Western blot analysis. Recombinant human pro-ANP and its derivatives in the conditioned medium were analyzed as described in section II.2.7.2. To quantify pro-ANP processing, protein bands were analyzed using the spot density method of the ChemiImager™ 4400 (Alpha Innotech). For each corin propeptide mutant, density values for the pro-ANP and ANP bands in each individual lane were added and percentage of pro-ANP to ANP conversion calculated. The number was then put into relation to the processing activity of the full-length corin measured in the same experiment, which was set as 100 %. For the corin mutants, activity values for pro-ANP processing are represented in % relative to that of full-length corin. Densitometry data were determined from at least four independent experiments for each corin deletion or single amino acid mutant.

II.3.2.2 Cell surface protein expression of corin deletion mutants

Cell surface expression of corin proteins was detected using the ECL protein biotinylation module from Amersham following the manufacturer's instructions. In detail, HEK 293 cells grown to ~70 % confluency in 100-mm culture dishes were transiently transfected with 30 μ g expression vector for either full-length corin or corin mutants Δ Fz1, Δ Fz1R1-5 (Knappe, 1999), or Δ R1-5 mutant corin using Lipofectamine 2000. Controls included were an empty expression vector and plasmids for the two soluble forms of corin, EKsolCorin and EKshortCorin. After 16 h, the transfected cells were washed twice with ice-cold PBS. Thirty μ L of biotinylation reagent in 5 mL bicarbonate buffer was then added and incubated at 4 °C for 20 min. Since the biotinylation reagent does not penetrate cell membranes, it does not react with proteins in the cytoplasm. The biotinylation reaction was followed by two wash steps with PBS. The cells were lysed with 1 mL of lysis buffer (250 mM NaCl; 25 mM Tris-HCl, pH 7.5; 5 mM EDTA, 0.5 % NP-40, and one tablet of protease inhibitor per 15 mL). To remove cell debris, the lysate was then subjected to a 10-min centrifugation at 13,000 rpm at 4 °C. The corin proteins full-length, Δ Fz1, Δ Fz1R-5, Δ R1-5, or EKsolCorin and EKshortCorin in the supernatant were immunoprecipitated with an anti-Xpress-antibody or anti-V5 antibody. To detect total corin protein in cell lysates, samples were analyzed by SDS-PAGE and Western blotting using an HRP-conjugate of the same antibody used for the immunoprecipitation. The membranes were then stripped with a glycine solution (100 mM, pH 3) and re-probed with streptavidin, which was conjugated with HRP. Streptavidin binds specifically to biotin. Only the corin molecules that were expressed on the cell surface were detected in this step.